



RF360 Europe GmbH
A Qualcomm – TDK Joint Venture

SAW components

SAW Rx filter
Band 71 Rx filter

| | |
|----------------|-----------------|
| Series/type: | B8356 |
| Ordering code: | B39631B8356P810 |
| Date: | July 25, 2017 |
| Version: | 1.1 |

RF360 products mentioned within this document are offered by RF360 Europe GmbH and other subsidiaries of RF360 Holdings Singapore Pte. Ltd. (collectively, the “RF360 Subsidiaries”).

RF360 Holdings Singapore Pte. Ltd. is a joint venture of Qualcomm Global Trading Pte. Ltd. and EPCOS AG.

RF360 Europe GmbH, Anzinger Str. 13, München, Germany

© 2017 RF360 Europe GmbH and/or its affiliated companies. All rights reserved.

| | |
|-----------------------|--------------|
| SAW components | B8356 |
| SAW Rx filter | 634.5 |

Preliminary data sheet

These materials, including the information contained herein, may be used only for informational purposes by the customer. The RF360 Subsidiaries assume no responsibility for errors or omissions in these materials or the information contained herein. The RF360 Subsidiaries reserve the right to make changes to the product(s) or information contained herein without notice. The materials and information are provided on an AS IS basis, and the RF360 Subsidiaries assume no liability and make no warranty or representation, either expressed or implied, with respect to the materials, or any output or results based on the use, application, or evaluation of such materials, including, without limitation, with respect to the non-infringement of trademarks, patents, copyrights or any other intellectual property rights or other rights of third parties.

No use of this documentation or any information contained herein grants any license, whether express, implied, by estoppel or otherwise, to any intellectual property rights, including, without limitation, to any patents owned by QUALCOMM Incorporated or any of its subsidiaries.

Not to be used, copied, reproduced, or modified in whole or in part, nor its contents revealed in any manner to others without the express written permission of RF360 Europe GmbH.

Qualcomm and Qualcomm RF360 are trademarks of Qualcomm Incorporated, registered in the United States and other countries. RF360 is a trademark of Qualcomm Incorporated. Other product and brand names may be trademarks or registered trademarks of their respective owners.

This technical data may be subject to U.S. and international export, re-export, or transfer ("export") laws. Diversion contrary to U.S. and international law is strictly prohibited.

| | |
|-----------------------|--------------|
| SAW components | B8356 |
| SAW Rx filter | 634.5 |

Preliminary data sheet

Table of contents

1 [Application](#)..... 4

2 [Features](#)..... 4

3 [Package](#)..... 5

4 [Pin configuration](#)..... 5

5 [Matching circuit](#)..... 6

6 [Characteristics](#)..... 7

7 [Maximum ratings](#)..... 9

8 [Transmission coefficient](#)..... 10

9 [Reflection coefficients](#)..... 11

10 [Packing material](#)..... 12

11 [Marking](#)..... 16

12 [Soldering profile](#)..... 17

13 [Annotations](#)..... 18

14 [Cautions and warnings](#)..... 19

15 [Revision history](#)..... 20

[Important notes](#)..... 21

Preliminary data sheet

1 Application

- Carrier Aggregation 600 MHz SE Secondary Rx FE filter
- Usable pass band 35 MHz
- Unbalanced to unbalanced operation
- Impedance transformation from 50 Ω to 50 Ω

2 Features

- Package size 1.8 \pm 0.1 mm \times 1.4 \pm 0.1 mm
- Package height 0.475 mm (max.)
- Approximate weight 4 mg
- RoHS compatible
- Package for Surface Mount Technology (SMT)
- Ni/Au-plated terminals
- Electrostatic Sensitive Device (ESD)
- Moisture Sensitivity Level 3 (MSL3)

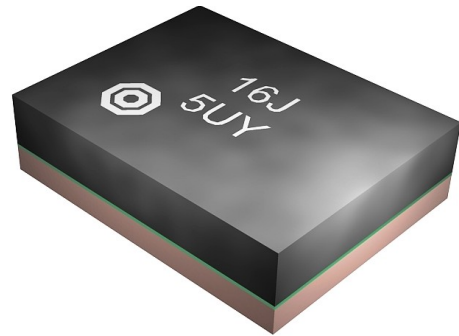
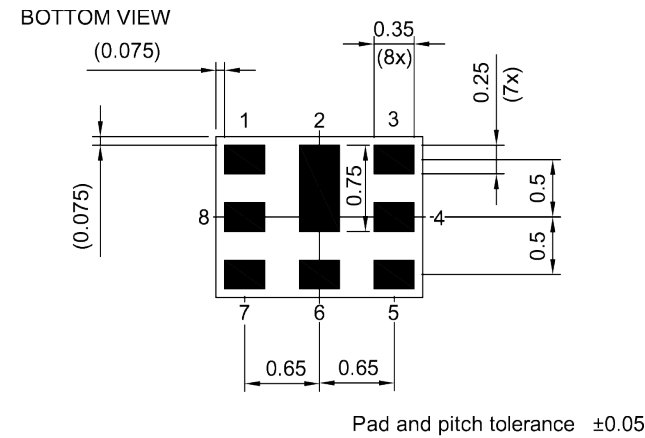

Figure 1: Picture of component with example of product marking.

SAW components **B8356**
SAW Rx filter **634.5**

Preliminary data sheet

3 Package



SIDE VIEW

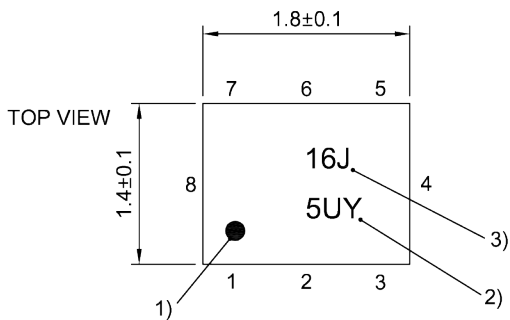
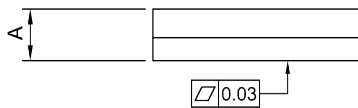

- 1) Marking for pad number 1
- 2) Example of encoded lot number
- 3) Example of encoded filter type number

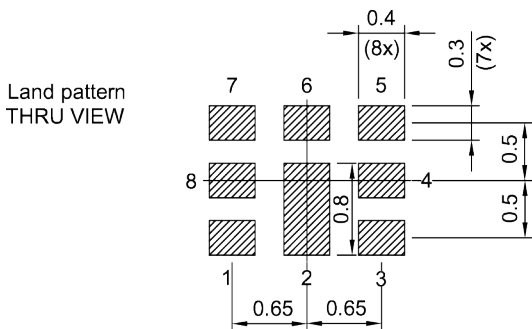

Figure 2: Drawing of package with package height A = 0.475 mm (max.). See Sec. Package information (p. 19).

4 Pin configuration

- 3 Output
- 6 Input
- 1, 2, 4, 5, 7, 8 Ground

Preliminary data sheet

5 Matching circuit

■ $L_{p3} = 10 \text{ nH}$

■ $L_{s6} = 11 \text{ nH}$

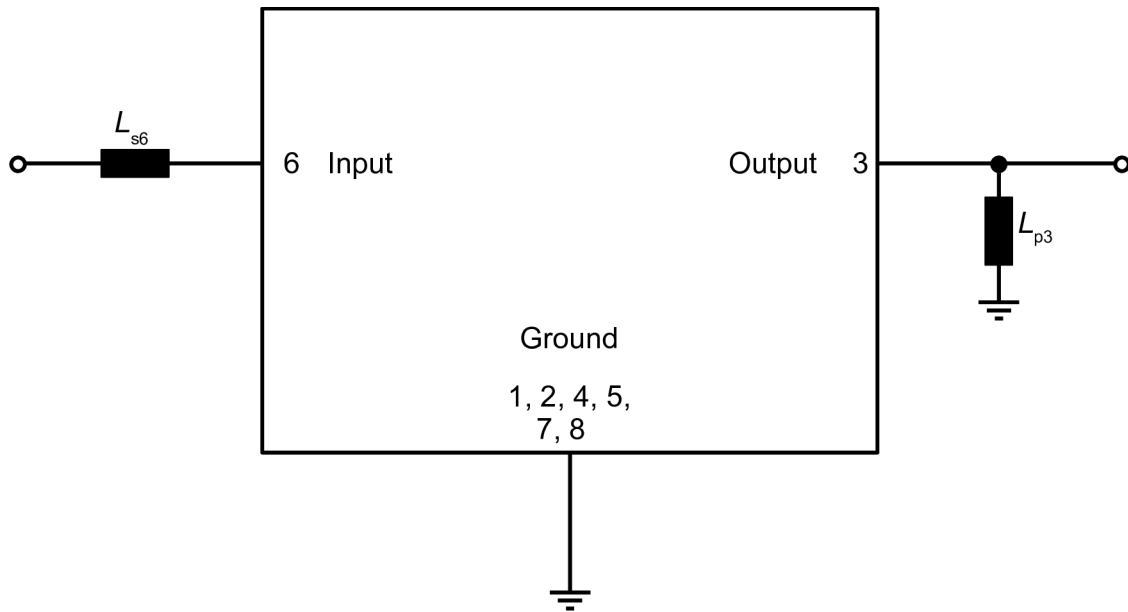

Figure 3: Schematic of matching circuit.

External shunt inductor for ESD protection is recommended at any ports towards antenna.

SAW components

B8356

SAW Rx filter

634.5

Preliminary data sheet

6 Characteristics

| | | |
|-------------------------------------|------------|---|
| Temperature range for specification | T_{SPEC} | = -30 °C ... +85 °C |
| Input terminating impedance | Z_{IN} | = 50 Ω with ser. 11 nH ¹⁾ |
| Output terminating impedance | Z_{OUT} | = 50 Ω with par. 10 nH ¹⁾ |

| Characteristics | | min. for T_{SPEC} | typ. @ +25 °C | max. for T_{SPEC} | |
|--------------------------------------|-----------------------------------|------------------------|------------------|------------------------|-----|
| Center frequency | f_C | — | 634.5 | — | MHz |
| Maximum insertion attenuation | α_{max} | — | 1.5 | 2.0 | dB |
| | 617.34... 651.66 MHz | | | | |
| Amplitude ripple (p-p) | $\Delta\alpha$ | — | 0.5 | 1.5 | dB |
| | 617.34... 651.66 MHz | | | | |
| Maximum VSWR | $VSWR_{max}$ | — | 1.7 | 2.2 | |
| @ input port | 617.34... 651.66 MHz | | | | |
| @ output port | 617.34... 651.66 MHz | | | | |
| Average attenuation | $\alpha_{WLAN,avg}$ ²⁾ | 15 | 25 | — | dB |
| | 657.5625... 662.4375 MHz | | | | |
| Minimum attenuation | α_{min} | 30 | 37 | — | dB |
| | 1.0... 608 MHz | | | | |
| | 35... 55 MHz | 50 | 85 | — | |
| | 205... 218 MHz | 40 | 71 | — | |
| | 308.5... 326 MHz | 40 | 64 | — | |
| | 532... 557 MHz | 30 | 60 | — | |
| | 663... 698 MHz | 39 | 42 | — | |
| | 709... 740 MHz | 30 | 50 | — | |
| | 712... 737 MHz | 30 | 50 | — | |
| | 737... 8000 MHz | 20 | 35 | — | |
| | 793... 805 MHz | 35 | 61 | — | |
| | 816... 818 MHz | 40 | 67 | — | |
| | 1058... 1138 MHz | 30 | 48 | — | |
| | 1163... 1204 MHz | 35 | 48 | — | |
| | 1233... 1281 MHz | 35 | 49 | — | |
| | 1234... 1304 MHz | 30 | 49 | — | |
| | 1280... 1350 MHz | 40 | 50 | — | |
| | 1461... 1484 MHz | 35 | 51 | — | |
| | 1653... 1698 MHz | 30 | 50 | — | |
| | 1710... 1755 MHz | 30 | 51 | — | |
| | 1850... 1910 MHz | 30 | 52 | — | |
| | 1851... 1956 MHz | 30 | 52 | — | |
| | 1943... 2048 MHz | 40 | 52 | — | |
| | 2305... 2315 MHz | 30 | 55 | — | |
| | 2327... 2407 MHz | 30 | 54 | — | |

| | |
|-----------------------|--------------|
| SAW components | B8356 |
| SAW Rx filter | 634.5 |

Preliminary data sheet

| Characteristics | | min. for T_{SPEC} | typ. @ +25 °C | max. for T_{SPEC} | |
|-----------------|------------------|------------------------|------------------|------------------------|----|
| | 2400... 2500 MHz | 30 | 55 | — | dB |
| | 2468... 2608 MHz | 30 | 55 | — | dB |
| | 2922... 2967 MHz | 30 | 50 | — | dB |
| | 4900... 5950 MHz | 20 | 43 | — | dB |
| | 5553... 5868 MHz | 20 | 44 | — | dB |
| | 6170... 6520 MHz | 20 | 35 | — | dB |

¹⁾ See Sec. Matching circuit (p. 6).

²⁾ Average over each WLAN channel with band width of 4.875 MHz.

SAW components

B8356

SAW Rx filter

634.5

Preliminary data sheet

7 Maximum ratings

| | | |
|---|---|-------------------------------------|
| Storage temperature | $T_{STG}^{2)} = -40\text{ °C} \dots +85\text{ °C}^{1)}$ | |
| DC voltage | $ V_{DC} ^{4)} = 0\text{ V (max.)}^{3)}$ | |
| ESD voltage | | |
| | $V_{ESD}^{5)} = \text{t.b.d. V (max.)}$ | Machine model. |
| | $V_{ESD}^{6)} = \text{t.b.d. V (max.)}$ | Human body model. |
| | $V_{ESD}^{7)} = \text{t.b.d. V (max.)}$ | Charged device model. |
| Input power @ input port: 663 ... 698 MHz | $P_{IN} = 15\text{ dBm}$ | Continuous wave for 2000 h @ 50 °C. |

¹⁾ Extended upperlimit: 96h@125 °C acc. to IEC 60068-2-2 Bb.

²⁾ Not valid for packaging material. Storage temperature for packaging material is -25 °C to +40 °C.

³⁾ In case of applied DC voltage to RF port, a DC blocking capacitor at RF port is mandatory.

⁴⁾ In case of applied DC voltage blocking capacitors are mandatory.

⁵⁾ According to JESD22-A115B (MM – Machine Model), 10 negative & 10 positive pulses.

⁶⁾ According to JESD22-A114F (HBM – Human Body Model), 1 negative & 1 positive pulse.

⁷⁾ According to JESD22-C101C (CDM – Field Induced Charged Device Model), 3 negative & 3 positive pulses.

| | |
|----------------|-------|
| SAW components | B8356 |
| SAW Rx filter | 634.5 |

Preliminary data sheet

8 Transmission coefficient

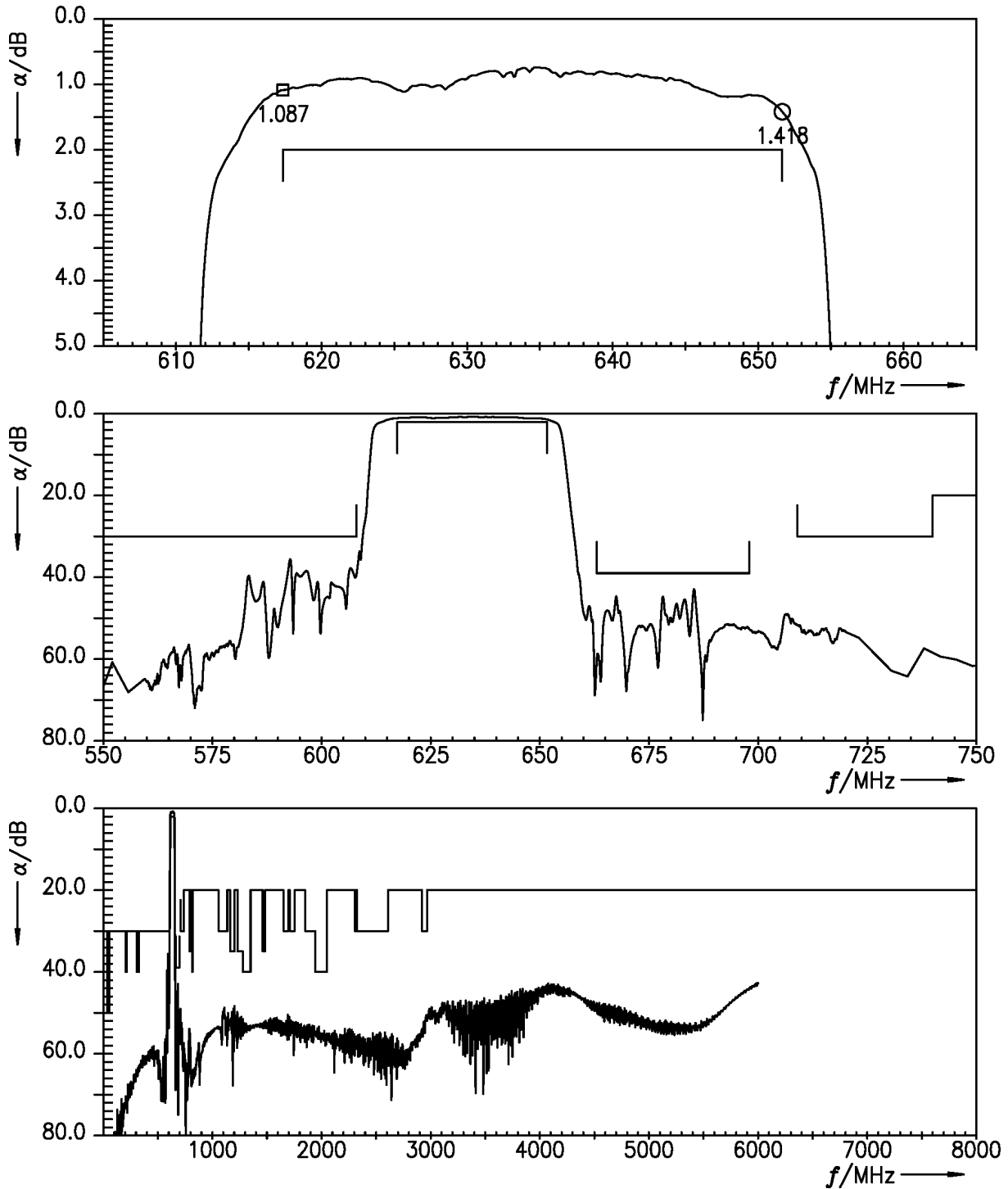

Figure 4: Attenuation.

| | |
|----------------|-------|
| SAW components | B8356 |
| SAW Rx filter | 634.5 |

Preliminary data sheet

9 Reflection coefficients

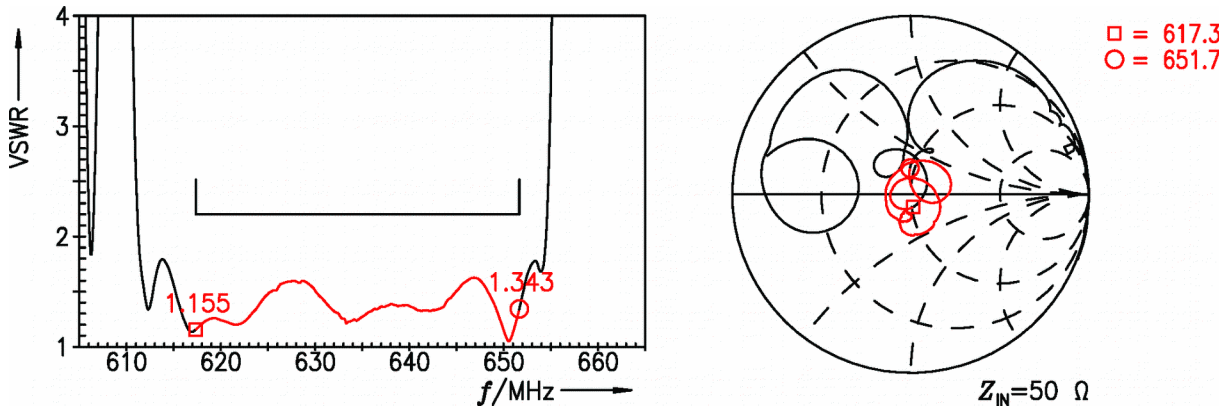

Figure 5: Reflection coefficient at IN port.

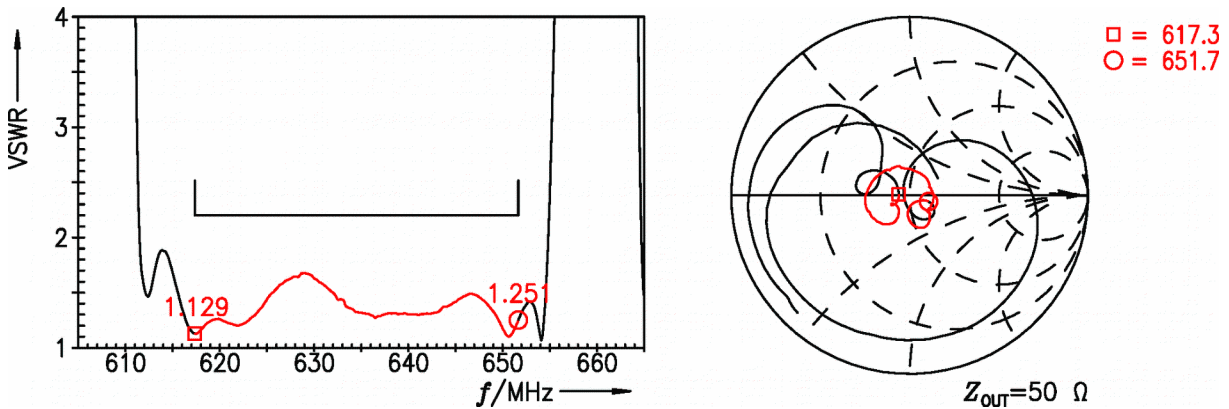

Figure 6: Reflection coefficient at OUT port.

| | |
|-----------------------|--------------|
| SAW components | B8356 |
| SAW Rx filter | 634.5 |

Preliminary data sheet

10 Packing material

10.1 Tape

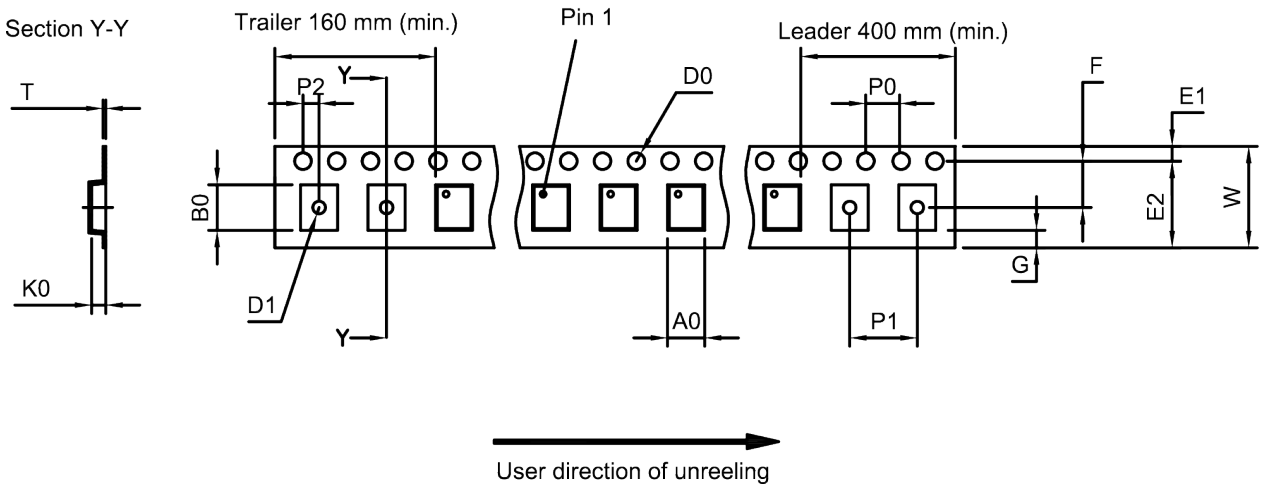

Figure 7: Drawing of tape (first-angle projection) with tape dimensions according to Table 1.

| | | | | | |
|----------------|--------------|----------------|----------------|----------------|--------------|
| A ₀ | 1.62±0.05 mm | E ₂ | 6.25 mm (min.) | P ₁ | 4.0±0.1 mm |
| B ₀ | 2.04±0.05 mm | F | 3.5±0.05 mm | P ₂ | 2.0±0.05 mm |
| D ₀ | 1.5±0.05 mm | G | 0.75 mm (min.) | T | 0.25±0.02 mm |
| D ₁ | 0.8±0.05 mm | K ₀ | 0.62±0.05 mm | W | 8.0±0.1 mm |
| E ₁ | 1.75±0.1 mm | P ₀ | 4.0±0.1 mm | | |

Table 1: Tape dimensions.

| | |
|----------------|-------|
| SAW components | B8356 |
| SAW Rx filter | 634.5 |

Preliminary data sheet

10.2 Reel with diameter of 180 mm

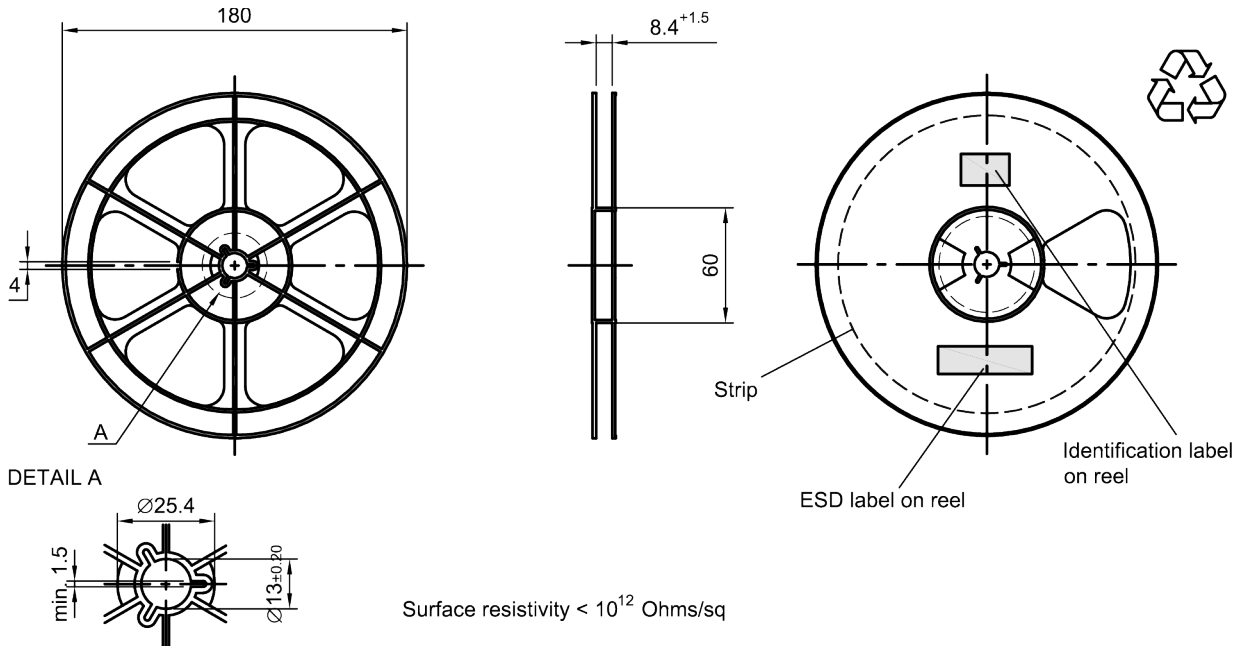

Figure 8: Drawing of reel (first-angle projection) with diameter of 180 mm.

Dimensions [mm]

X = 220+5

Y = 235+5

Sealing area 10±3

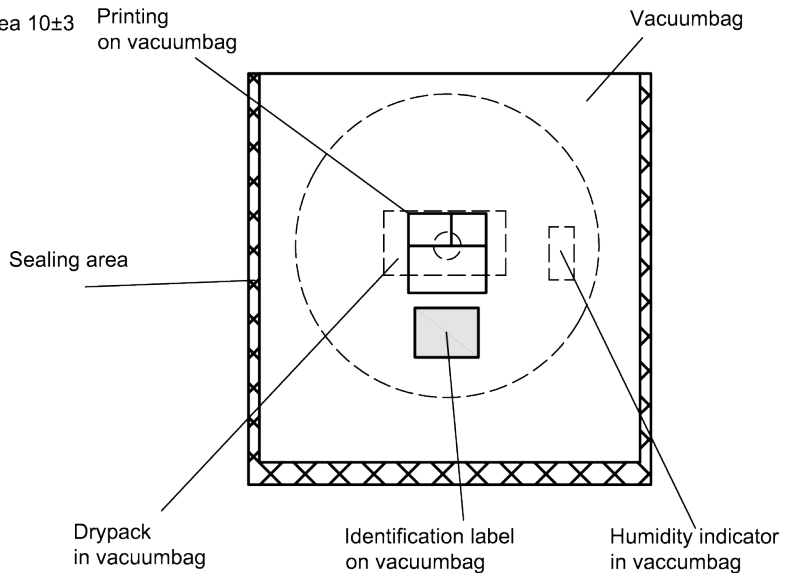

Figure 9: Drawing of moisture barrier bag (MBB) for reel with diameter of 180 mm.

| | |
|-----------------------|--------------|
| SAW components | B8356 |
| SAW Rx filter | 634.5 |

Preliminary data sheet

Dimensions [mm]
 L = 188
 B = 188
 H = 30
 Tolerance ±5

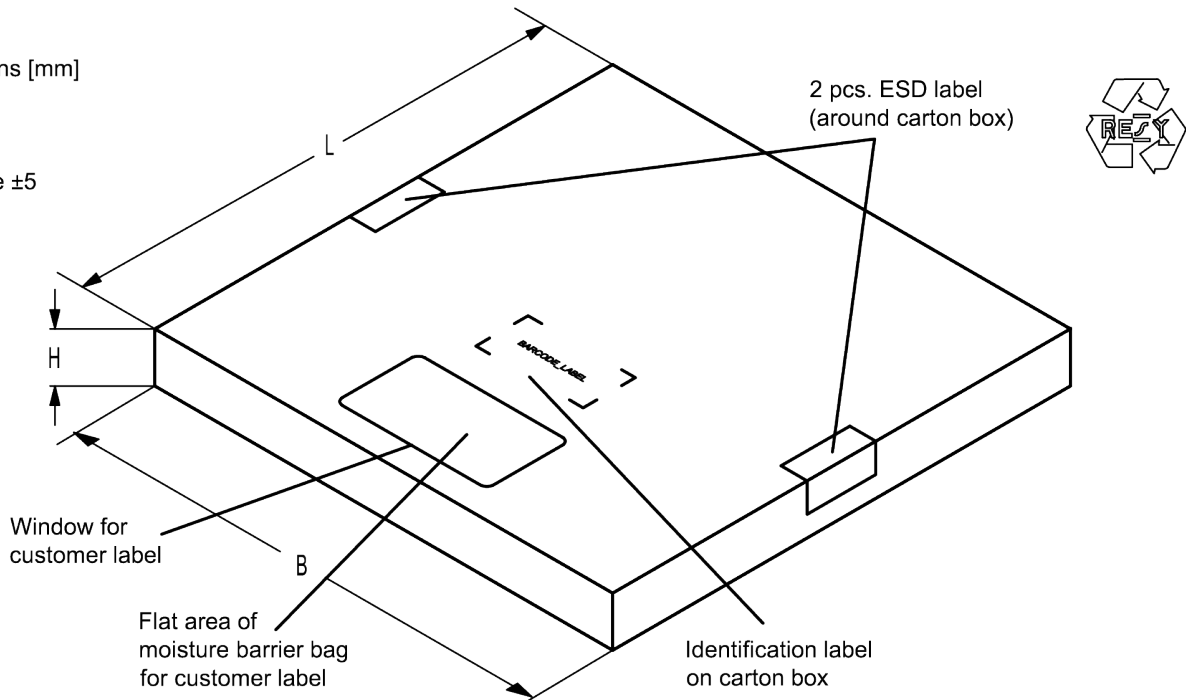

Figure 10: Drawing of folding box for reel with diameter of 180 mm.

10.3 Reel with diameter of 330 mm

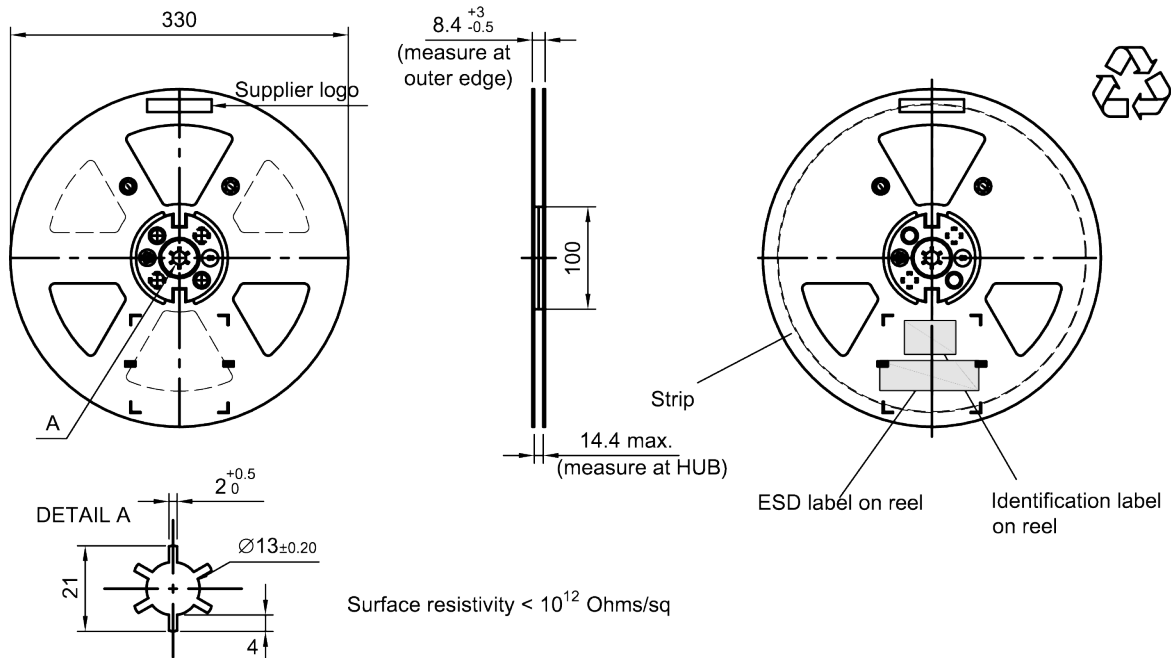

Figure 11: Drawing of reel (first-angle projection) with diameter of 330 mm.

| | |
|-----------------------|--------------|
| SAW components | B8356 |
| SAW Rx filter | 634.5 |

Preliminary data sheet

Dimensions [mm]

X = 400+5

Y = 418+5

Sealing area 10±3

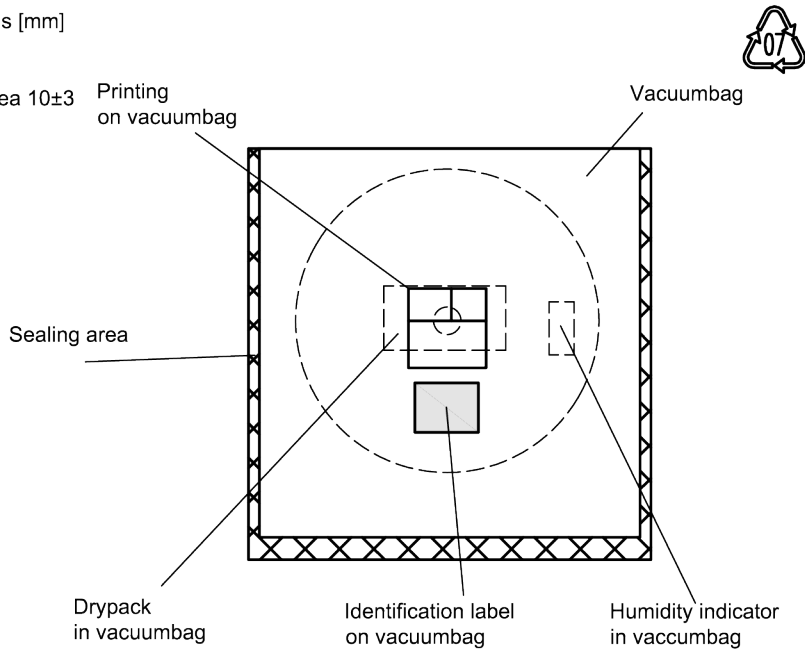

Figure 12: Drawing of moisture barrier bag (MBB) for reel with diameter of 330 mm.

Dimensions [mm]

L = 335

B = 338

H = 36 (for 8 mm tape width)

40 (for 12 mm tape width)

Tolerance ±5

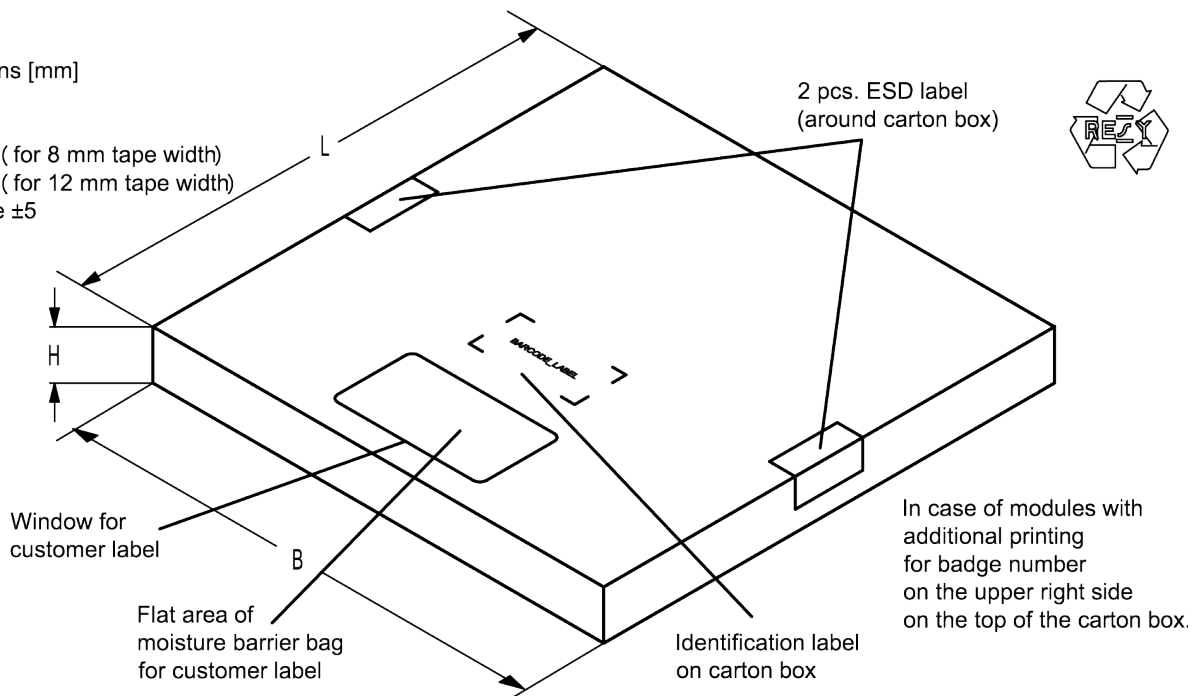

Figure 13: Drawing of folding box for reel with diameter of 330 mm.

| | |
|-----------------------|--------------|
| SAW components | B8356 |
| SAW Rx filter | 634.5 |

Preliminary data sheet

11 Marking

Products are marked with product type number and lot number encoded according to Table 2:

■ Type number:

The 4 digit type number of the ordering code, e.g., B3xxxxB**1234**xxxx, is encoded by a special BASE32 code into a 3 digit marking.

Example of decoding type number marking on device in decimal code.
16J => **1234**
 $1 \times 32^2 + 6 \times 32^1 + 18 (=J) \times 32^0 =$ **1234**

The BASE32 code for product type B8356 is 854.

■ Lot number:

The last 5 digits of the lot number, e.g., **12345**, are encoded based on a special BASE47 code into a 3 digit marking.

Example of decoding lot number marking on device in decimal code.
5UY => **12345**
 $5 \times 47^2 + 27 (=U) \times 47^1 + 31 (=Y) \times 47^0 =$ **12345**

| Adopted BASE32 code for type number | | | |
|-------------------------------------|-------------|---------------|-------------|
| Decimal value | Base32 code | Decimal value | Base32 code |
| 0 | 0 | 16 | G |
| 1 | 1 | 17 | H |
| 2 | 2 | 18 | J |
| 3 | 3 | 19 | K |
| 4 | 4 | 20 | M |
| 5 | 5 | 21 | N |
| 6 | 6 | 22 | P |
| 7 | 7 | 23 | Q |
| 8 | 8 | 24 | R |
| 9 | 9 | 25 | S |
| 10 | A | 26 | T |
| 11 | B | 27 | V |
| 12 | C | 28 | W |
| 13 | D | 29 | X |
| 14 | E | 30 | Y |
| 15 | F | 31 | Z |

| Adopted BASE47 code for lot number | | | |
|------------------------------------|-------------|---------------|-------------|
| Decimal value | Base47 code | Decimal value | Base47 code |
| 0 | 0 | 24 | R |
| 1 | 1 | 25 | S |
| 2 | 2 | 26 | T |
| 3 | 3 | 27 | U |
| 4 | 4 | 28 | V |
| 5 | 5 | 29 | W |
| 6 | 6 | 30 | X |
| 7 | 7 | 31 | Y |
| 8 | 8 | 32 | Z |
| 9 | 9 | 33 | b |
| 10 | A | 34 | d |
| 11 | B | 35 | f |
| 12 | C | 36 | h |
| 13 | D | 37 | n |
| 14 | E | 38 | r |
| 15 | F | 39 | t |
| 16 | G | 40 | v |
| 17 | H | 41 | \ |
| 18 | J | 42 | ? |
| 19 | K | 43 | { |
| 20 | L | 44 | } |
| 21 | M | 45 | < |
| 22 | N | 46 | > |
| 23 | P | | |

Table 2: Lists for encoding and decoding of marking.

Preliminary data sheet

12 Soldering profile

The recommended soldering process is in accordance with IEC 60068-2-58 – 3rd edit and IPC/JEDEC J-STD-020B.

| | |
|--------------------------------------|--|
| ramp rate | ≤ 3 K/s |
| preheat | 125 °C to 220 °C, 150 s to 210 s, 0.4 K/s to 1.0 K/s |
| $T > 220$ °C | 30 s to 70 s |
| $T > 230$ °C | min. 10 s |
| $T > 245$ °C | max. 20 s |
| $T \geq 255$ °C | – |
| peak temperature T_{peak} | 250 °C +0/-5 °C |
| wetting temperature T_{min} | 230 °C +5/-0 °C for 10 s ± 1 s |
| cooling rate | ≤ 3 K/s |
| soldering temperature T | measured at solder pads |

Table 3: Characteristics of recommended soldering profile for lead-free solder (Sn95.5Ag3.8Cu0.7).

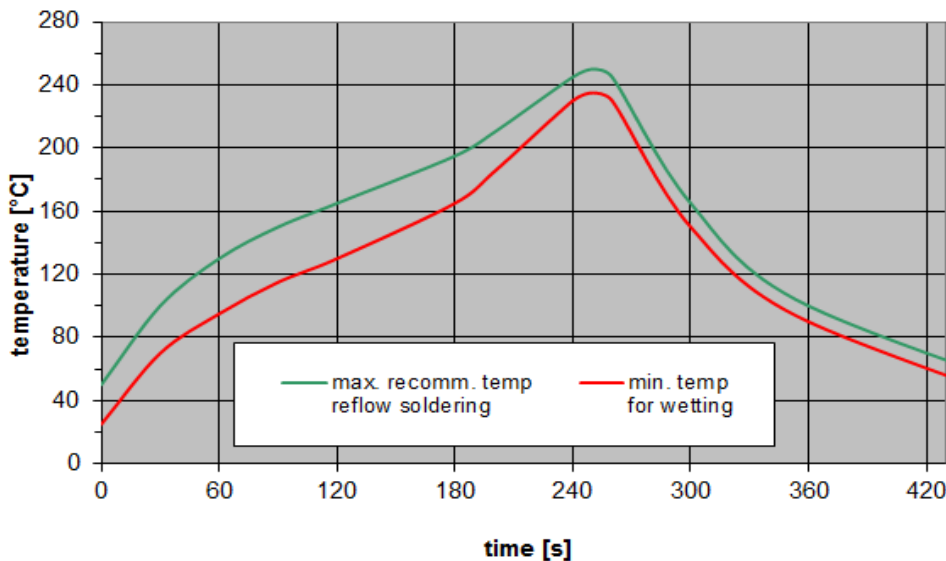

Figure 14: Recommended reflow profile for convection and infrared soldering – lead-free solder.

| | |
|-----------------------|--------------|
| SAW components | B8356 |
| SAW Rx filter | 634.5 |

Preliminary data sheet

13 Annotations

13.1 Matching coils

See TDK inductor pdf-catalog <http://www.tdk.co.jp/tefe02/coil.htm#aname1> and Data Library for circuit simulation <http://www.tdk.co.jp/etvcl/index.htm>.

13.2 RoHS compatibility

ROHS-compatible means that products are compatible with the requirements according to Art. 4 (substance restrictions) of Directive 2011/65/EU of the European Parliament and of the Council of June 8th, 2011, on the restriction of the use of certain hazardous substances in electrical and electronic equipment ("Directive") with due regard to the application of exemptions as per Annex III of the Directive in certain cases.

13.3 Scattering parameters (S-parameters)

The pin/port assignment is available in the headers of the S-parameter files. Please contact your local RF360 sales office.

| | |
|-----------------------|--------------|
| SAW components | B8356 |
| SAW Rx filter | 634.5 |

Preliminary data sheet

14 Cautions and warnings

14.1 Display of ordering codes for RF360 products

The ordering code for one and the same product can be represented differently in data sheets, data books, other publications and the website of RF360, or in order-related documents such as shipping notes, order confirmations and product labels. The varying representations of the ordering codes are due to different processes employed and do not affect the specifications of the respective products. Detailed information can be found on the Internet under www.rf360jv.com/orderingcodes.

14.2 Material information

Due to technical requirements components may contain dangerous substances. For information on the type in question please also contact one of our sales offices.

For information on recycling of tapes and reels please contact one of our sales offices.

14.3 Moldability

Before using in overmolding environment, please contact your local RF360 sales office.

14.4 Package information

Landing area

The printed circuit board (PCB) land pattern (landing area) shown is based on RF360 internal development and empirical data and illustrated for example purposes, only. As customers' SMD assembly processes may have a plenty of variants and influence factors which are not under control or knowledge of RF360, additional careful process development on customer side is necessary and strongly recommended in order to achieve best soldering results tailored to the particular customer needs.

Dimensions

Unless otherwise specified all dimensions are understood using unit millimeter (mm).

Projection method

Unless otherwise specified first-angle projection is applied.

| | |
|-----------------------|--------------|
| SAW components | B8356 |
| SAW Rx filter | 634.5 |

Preliminary data sheet

15 Revision history

Changes compared to previously issued iteration.

| Version | Originator | Detailed specification changes | Date |
|---------|--------------|--------------------------------|--------------|
| 1.0 | C. Binninger | Preliminary datasheet. | Jul 19, 2017 |
| 1.1 | C. Binninger | Preliminary datasheet. | Jul 25, 2017 |

Important notes

The following applies to all products named in this publication:

1. Some parts of this publication contain **statements about the suitability of our products for certain areas of application**. These statements are based on our knowledge of typical requirements that are often placed on our products in the areas of application concerned. We nevertheless expressly point out **that such statements cannot be regarded as binding statements about the suitability of our products for a particular customer application**. As a rule, RF360 Europe GmbH and its affiliates are either unfamiliar with individual customer applications or less familiar with them than the customers themselves. For these reasons, it is always ultimately incumbent on the customer to check and decide whether an RF360 product with the properties described in the product specification is suitable for use in a particular customer application.
2. We also point out that **in individual cases, a malfunction of electronic components or failure before the end of their usual service life cannot be completely ruled out in the current state of the art, even if they are operated as specified**. In customer applications requiring a very high level of operational safety and especially in customer applications in which the malfunction or failure of an electronic component could endanger human life or health (e.g. in accident prevention or life-saving systems), it must therefore be ensured by means of suitable design of the customer application or other action taken by the customer (e.g. installation of protective circuitry or redundancy) that no injury or damage is sustained by third parties in the event of malfunction or failure of an electronic component.
3. **The warnings, cautions and product-specific notes must be observed.**
4. In order to satisfy certain technical requirements, **some of the products described in this publication may contain substances subject to restrictions in certain jurisdictions (e.g. because they are classed as hazardous)**. Useful information on this will be found in our Material Data Sheets on the Internet (www.rf360jv.com/material). Should you have any more detailed questions, please contact our sales offices.
5. We constantly strive to improve our products. Consequently, **the products described in this publication may change from time to time**. The same is true of the corresponding product specifications. Please check therefore to what extent product descriptions and specifications contained in this publication are still applicable before or when you place an order. We also **reserve the right to discontinue production and delivery of products**. Consequently, we cannot guarantee that all products named in this publication will always be available.
The aforementioned does not apply in the case of individual agreements deviating from the foregoing for customer-specific products.

单击下面可查看定价，库存，交付和生命周期等信息

[>>RF360 / Qualcomm](#)