

10/100BASE-TX/FX Octal- Φ TM Transceiver

GENERAL DESCRIPTION

The BCM5228 is an octal 10/100BASE-TX/FX transceiver targeted at Fast Ethernet switches. The device contains eight full-duplex 10BASE-T/100BASE-TX/FX Fast Ethernet transceivers, each of which perform all of the physical layer interface functions for 10BASE-T Ethernet on Category 3, 4, or 5 unshielded twisted-pair (UTP) cable and 100BASE-TX Fast Ethernet on Category 5 UTP cable. The 100BASE-FX is supported at each port through the use of external fiber-optic transmit and receive devices.

The BCM5228 is a highly integrated solution combining digital adaptive equalizers, ADCs, phase locked loops, line drivers, encoders, decoders, and the required support circuitry into a single monolithic CMOS chip. The BCM5228 complies with the IEEE 802.3 specification, including the auto-negotiation subsections.

The effective use of digital technology in the BCM5228 design results in robust performance over a broad range of operating scenarios. Problems inherent to mixed-signal implementations (such as analog offset and on-chip noise) are eliminated by employing field-proven digital adaptive equalization and digital clock recovery techniques.

FEATURES

- 10BASE-T/100BASE-TX/FX IEEE 802.3u compliant
- Single-chip octal physical interface-RMII to magnetics
- Reduced Media Independent Interface (RMII)
- Option-Serial Media Independent Interface (SMII)
- Option-Source Synchronous SMII (S3MII)
- Fully integrated digital adaptive equalizers
- 125-MHz clock generator and timing recovery
- On-chip multimode transmit waveshaping
- Edge-rate control eliminates external filters
- Integrated baseline wander correction
- HP Auto-MDIX
- Cable length indication
- Cable noise level indication
- IEEE 802.3u-compliant Auto-Negotiation
- Shared MII management interface up to 25 Mbps
- Serial LED status pins
- Programmable parallel LED pins
- Interrupt output capability
- Loopback mode for diagnostics
- IEEE 1149.1 (JTAG) and NAND chain ICT support
- Low-power dual-supply 2.5V/3.3V CMOS technology
- Compatible with 2.5V/3.3V I/O
- 208-pin PQFP and 256-pin FPBGA packages

APPLICATIONS

- Fast Ethernet switches

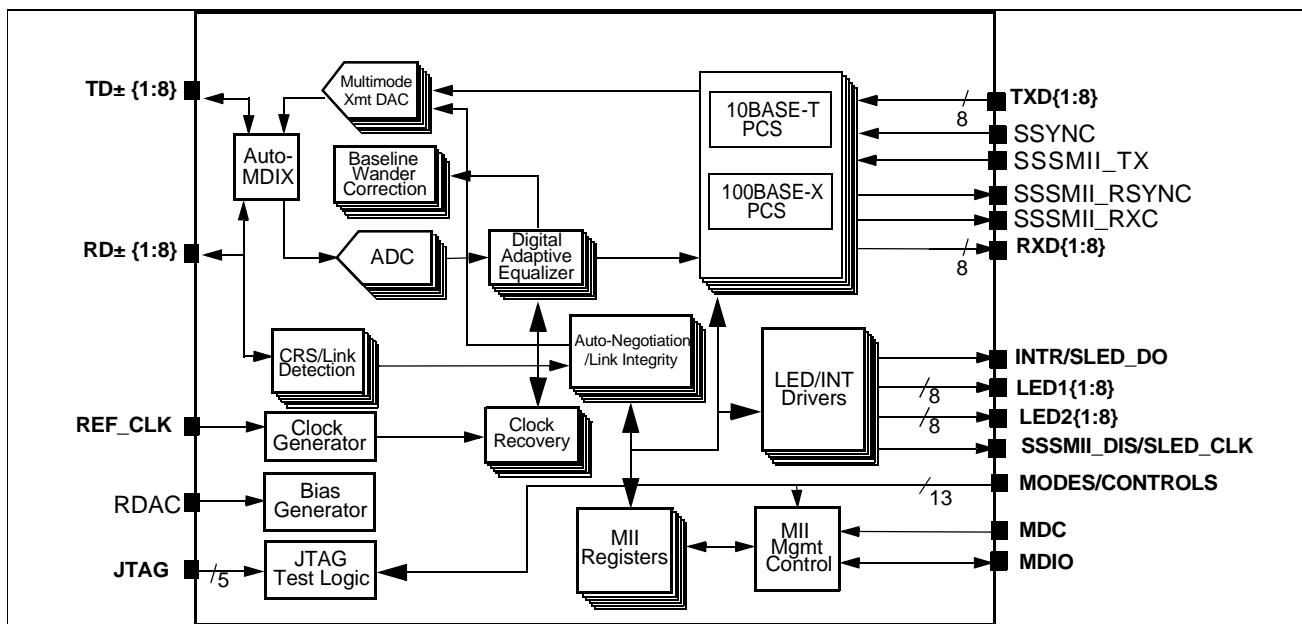

Figure 1: Functional Block Diagram

REVISION HISTORY

<i>Revision</i>	<i>Date</i>	<i>Change Description</i>
5228-DS08-R	06/02/03	<ul style="list-style-type: none"> Added 2.5V I/O-OVDD option under "Features" on the cover. Added "HP Auto-MDIX" on page 26. Added SLED_CLK frequency to "Serial LED Mode" on page 27. Added description to bit 4, Activity LED, in Table 37, "Auxiliary Mode Register (Address 29d, 1Dh)," on page 57.
5228-DS07-R	09/09/02	<ul style="list-style-type: none"> Added PLL VDD pin definition table and figures. Included details on Isolate mode, super Isolate mode, and Auto Power-Down mode. Included bit 15 (FDX LED enable) changes to serial LED mode. Included Jumbo Packet mode bits and descriptions. Show correct default value for shadow register 1Ah.
5228-DS06-R	03/07/02	<p>Updated the following:</p> <ul style="list-style-type: none"> "MII Register Map Summary" table. "Clock and Reset Timing" figure. "Packaging Thermal Characteristics" section. "Ordering Information" section.
5228-DS05-R	10/24/01	<ul style="list-style-type: none"> Added ordering information; added minor table information updates.
5228-DS04-R	03/15/01	<ul style="list-style-type: none"> Added the following to "Features" on the cover: <ul style="list-style-type: none"> Option-source synchronous SMII (S3MII) HP Auto-MDIX Cable Length Indication Cable Noise Level Indication Following Table 32, deleted from Interrupt Enable description "Bits 14 and 15 of this register are mutually exclusive. Only one may be set at a time." In Table 49, inserted TYP values for parameters TD± after TXEN Assert and TXD to TD± Steady State Delay. In Table 50, added TYP values for parameter CRS_DV Assert after RD±, CRS_DV Deassert after RD±, and CRS_DV Deassert after RD±, Valid EOP. Deleted last row (parameter RD± to CRS_DV Steady State Delay). In Table 57, added TYP and MAX values for Total Supply Current for AVDD, DVDD and OVDD pins. Added Section 10: "Packaging Thermal Characteristics." Corrected specification of register 19h, bit 0 from <i>jabber detect</i> to <i>full-duplex indication</i>.
5228-DS03-R	09/01/00	<ul style="list-style-type: none"> Correct several signal name inconsistencies. Changed P14 from PLLVDDP to OVDD in: <ul style="list-style-type: none"> Tables 2 and 3 Figures 1, 2, and 3 Changed AGND from C05 to C06 in Table 3. Modified description for "100BASE-FX Mode". Changed LED_CLK to SLED_CLK for "Low-Cost Serial LED Mode." Changed address 1Ah bit 15 in Table 15 from <i>FDX LED Enable</i> to <i>Reserved</i>. Deleted FDX LED Enable bit description for Table 32. Added TX_ER parameter to Table 49. Added CRS_DV, RX_ER, and note 3 to Table 50. Changed SRD_Delay to SRX_Delay in Figure 8. Deleted reference to IVDD in Table 57.
5228-DS02-R	12/15/99	Added MDIX info to page 49. Minor editorial changes.
5228-DS01-R	11/24/99	Initial release.



Broadcom Corporation

P.O. Box 57013

16215 Alton Parkway

Irvine, CA 92619-7013

© 2003 by Broadcom Corporation

All rights reserved

Printed in the U.S.A.

Broadcom® and the pulse logo are registered trademarks of Broadcom Corporation and/or its subsidiaries in the United States and certain other countries. All other trademarks are the property of their respective owners.

TABLE OF CONTENTS

Section 1: Functional Description	1
Overview	1
Encoder/Decoder	1
Link Monitor	2
Carrier Sense	2
Auto-Negotiation	3
Digital Adaptive Equalizer	3
ADC	3
Digital Clock Recovery/Generator	3
Baseline Wander Correction	3
Multimode Transmit DAC	4
Stream Cipher	5
Far-End Fault	5
Reduced Media Independent Interface (RMII)	5
MII Management	6
Serial Media Independent Interface (SMII)	6
Interrupt Mode	7
Section 2: Hardware Signal Definition Table	9
Section 3: Pinout Diagrams	17
Section 4: Operational Description	23
Resetting the BCM5228	23
Loopback Mode	23
Full-Duplex Mode	23
100BASE-FX Mode	23
10BASE-T Mode	24
Isolate Mode	24
Super Isolate Mode	24
Auto Power-Down Mode	24
Jumbo Packet Mode	25
PHY Address	25



Section 5: LED Modes	27
Description	27
Serial LED Mode	27
Low-Cost Serial LED Mode	28
Parallel LED Mode	31
Section 6: Register Summary	33
MII Management Interface: Register Programming	33
MII Register Map Summary.....	35
MII Control Register	37
MII Status Register	39
PHY Identifier Registers	40
Auto-Negotiation Advertisement Register	41
Auto-Negotiation Link Partner (LP) Ability Register	42
Auto-Negotiation Expansion Register	43
Auto-Negotiation Next Page Register	44
Auto-Negotiation Link Partner (LP) Next Page Transmit Register	45
100BASE-X Auxiliary Control Register	46
100BASE-X Auxiliary Status Register	47
100BASE-X Receive Error Counter	48
100BASE-X False Carrier Sense Counter	49
100BASE-X Disconnect Counter	49
Auxiliary Control/Status Register	50
Auxiliary Status Summary Register	52
Interrupt Register	53
Auxiliary Mode 2 Register	54
10BASE-T Auxiliary Error and General Status Register	55
Auxiliary Mode Register	57
Auxiliary Multiple PHY Register	58
Broadcom Test Register	59
Auxiliary Mode 4 (PHY 1) Register (Shadow Register)	60
Auxiliary Mode 4 (PHY 2) Register (Shadow Register)	61
Auxiliary Mode 4 (PHY 3) Register (Shadow Register)	62
Auxiliary Status 2 Register (Shadow Register)	63
Auxiliary Status 3 Register (Shadow Register)	64



Auxiliary Mode 3 Register (Shadow Register).....	65
Auxiliary Status 4 Register (Shadow Register)	66
Section 7: Timing and AC Characteristics	67
Section 8: Electrical Characteristics.....	73
Section 9: Mechanical Information.....	75
Section 10: Packaging Thermal Characteristics.....	77
Section 11: Application Examples	79
Section 12: Ordering Information.....	83





LIST OF FIGURES

Figure 1: Functional Block Diagram	i
Figure 2: BCM5228F Pinout Diagram	17
Figure 3: BCM5228U Pinout Diagram	18
Figure 4: BGA Pinout (Top View)	19
Figure 5: Clock and Reset Timing	67
Figure 6: RMII Transmit Packet Timing	68
Figure 7: RMII Receive Packet Timing	69
Figure 8: RMII Receive Packet with False Carrier.....	69
Figure 9: SMII/S3MII Timing	70
Figure 10: Management Interface Timing.....	71
Figure 11: Management Interface Timing (with Preamble Suppression On).....	71
Figure 12: 208-Pin PQFP Package	75
Figure 13: 256-Pin Fine Pitch BGA (FPBGA) Package.....	76
Figure 14: SMII Application	79
Figure 15: SMII Application using Source Synchronous Signals.....	80
Figure 16: Switch Application	81



LIST OF TABLES

Table 1: 4B5B Encoding.....	4
Table 2: Pin Definitions.....	9
Table 3: BGA Ballout by Signal Name.....	20
Table 4: Receive FIFO Size Select	25
Table 5: Jumbo Packet Enable and Descrambler Lock Timer	26
Table 6: Serial LED Mode Bit Framing	27
Table 7: Low-Cost Serial Mode Bank 1 LED Selection	28
Table 8: Low-Cost Serial Mode Bank 2 LED Selection	28
Table 11: Low-Cost Serial Mode Bank 5 LED Selection	29
Table 9: Low-Cost Serial Mode Bank 3 LED Selection	29
Table 10: Low-Cost Serial Mode Bank 4 LED Selection	29
Table 12: Low-Cost Serial Mode Bank 6 LED Selection	30
Table 13: Parallel LED Mode LED1 Selection	31
Table 14: Parallel LED Mode LED2 Selection	31
Table 15: Parallel LED Mode LED3 Selection	32
Table 16: MII Management Frame Format.....	33
Table 17: MII Register Map Summary.....	35
Table 18: MII Shadow Register Map Summary (MII Register 1Fh, bit7 = 1).....	36
Table 19: MII Control Register (Address 00d, 00h).....	37
Table 20: MII Status Register (Address 01d, 01h)	39
Table 21: PHY Identifier Registers (Addresses 02d and 03d, 02h and 03h).....	40
Table 22: Auto-Negotiation Advertisement Register (Address 04d, 04h).....	41
Table 23: Auto-Negotiation Link Partner Ability Register (Address 05d, 05h).....	42
Table 24: Auto-Negotiation Expansion Register (Address 06d, 06h).....	43
Table 25: Next Page Transmit Register (Address 07d, 07h).....	44
Table 26: Next Page Transmit Register (Address 08d, 08h).....	45
Table 27: 100-BASE-X Auxiliary Control Register (Address 16d, 10h).....	46
Table 28: 100BASE-X Auxiliary Status Register (Address 17d, 11h).....	47
Table 29: 100BASE-X Receive Error Counter (Address 18d, 12h).....	48
Table 30: 100BASE-X False Carrier Sense Counter (Address 19d, 13h).....	49
Table 31: 100BASE-X Disconnect Counter.....	49
Table 32: Auxiliary Control/Status Register (Address 24d, 18h)	50

Table 33: Auxiliary Status Summary Register (Address 25d, 19h).....	52
Table 34: Interrupt Register (Address 26d, 1Ah)	53
Table 35: Auxiliary Mode 2 Register (Address 27d, 1Bh)	54
Table 36: 10BASE-T Auxiliary Error and General Status Register (Address 28d, 1Ch).....	55
Table 37: Auxiliary Mode Register (Address 29d, 1Dh).....	57
Table 38: Auxiliary Multiple PHY Register (Address 30d, 1Eh)	58
Table 39: Broadcom Test (Address 31d, 1Fh).....	59
Table 40: Auxiliary Mode 4 (PHY 1) Register (Shadow Register 26d, 1Ah)	60
Table 41: Auxiliary Mode 4 (PHY 2) Register (Shadow Register 26d, 1Ah)	61
Table 42: Auxiliary Mode 4 (PHY 3) Register (Shadow Register 26d, 1Ah)	62
Table 43: Auxiliary Status 2 Register (Shadow Register 27d, 1Bh).....	63
Table 44: Cable Length.....	63
Table 45: Auxiliary Status 3 Register (Shadow Register 28d, 1Ch).....	64
Table 46: Auxiliary Mode 3 Register (Shadow Register 29d, 1Dh).....	65
Table 47: Current Receive FIFO Size.....	65
Table 48: Auxiliary Status 4 Register (Shadow Register 30d, 1Eh).....	66
Table 49: Clock Timing	67
Table 50: Reset Timing.....	67
Table 52: RMI Receive Timing.....	68
Table 51: RMI Transmit Timing.....	68
Table 53: SMII/S3MII Timing	69
Table 54: Auto-Negotiation Timing	70
Table 55: LED Timing	70
Table 56: MII Management Data Interface Timing.....	70
Table 58: Recommended Operating Conditions.....	73
Table 59: Electrical Characteristics.....	73
Table 60: Theta _{JA} vs. Airflow for the BCM5228B (256 FPBGA) Package.....	77
Table 61: Theta _{JA} vs. Airflow for the BCM5228F (208 PQFP) Package.....	77
Table 62: Theta _{JA} vs. Airflow for the BCM5228U (208 PQFP) Package.....	77
Table 63: Theta _{JA} vs. Airflow for the BCM5228B with Heat Sink.....	83



Section 1: Functional Description

OVERVIEW

The BCM5228 is a single-chip device containing eight independent Fast Ethernet transceivers. Each transceiver performs all of the physical layer interface functions for 100BASE-TX full-duplex or half-duplex Ethernet on Category 5 unshielded twisted-pair (UTP) cable, and 10BASE-T full-duplex or half-duplex Ethernet on Category 3, 4, or 5 UTP cable. Each port can also be configured for 100BASE-FX full-duplex or half-duplex transmission over fiber-optic cabling when paired with an external fiber-optic line driver and receiver.

The chip performs:

- 4B5B, MLT3, NRZI, and Manchester encoding and decoding
- Clock and data recovery
- Stream cipher scrambling/descrambling
- Digital adaptive equalization
- Line transmission
- Carrier sense and link integrity monitor
- Auto-negotiation
- RMII, SMII, S3MII, and management functions

The BCM5228 can be connected to a MAC through the RMII or SMII on one side, and directly to the network media on the other side through either:

- Isolation transformers for UTP modes
- Fiber-optic transmitter/receiver components for FX mode

The BCM5228 is compliant with the IEEE 802.3 standard.

ENCODER/DECODER

In 100BASE-TX and 100BASE-FX modes, the BCM5228 transmits and receives a continuous data stream on twisted-pair or fiber-optic cable. When the RMII Transmit Enable pin is asserted, data from the transmit data pins is encoded into 5-bit code groups and inserted into the transmit data stream. The 4B5B encoding is shown in [Table 1 on page 4](#). The transmit packet is encapsulated by replacing the first two nibbles of preamble with a start-of-stream delimiter (J/K codes) and appending an end-of-stream delimiter (T/R codes) to the end of the packet. The transmitter repeatedly sends the idle code group between packets.

In TX mode, the encoded data stream is scrambled by a stream cipher block and then serialized and encoded into MLT3 signal levels. A multimode transmit DAC is used to drive the MLT3 data onto the twisted-pair cable. In FX mode, the scrambling function is bypassed and the data is NRZI encoded. The multimode transmit DAC drives differential positive ECL (PECL) levels to an external fiber-optic transmitter.

Following baseline wander correction, adaptive equalization, and clock recovery in TX mode, the receive data stream is converted from MLT3 to serial NRZI data. The NRZI data is descrambled by the stream cipher block and then deserialized and aligned into 5-bit code groups.

In FX mode, the receive data stream differential PECL levels are sampled from the fiber-optic receiver. Baseline wander correction, adaptive equalization, and stream cipher descrambling functions are bypassed, and NRZI decoding is used instead of MLT3.

The 5-bit code groups are decoded into 4-bit data nibbles, as shown in [Table 1 on page 4](#). The start-of-stream delimiter is replaced with preamble nibbles, and the end-of-stream delimiter and idle codes are replaced with all zeros. The decoded data is driven onto the RMII/SMII receive data pins. When an invalid code group is detected in the data stream, the BCM5228 asserts the RMII/SMII RXER signal. The chip also asserts RXER for several other error conditions that improperly terminate the data stream. While RXER is asserted, the receive data pins are driven with a 01 for an invalid data reception and a 10 for a false carrier.

In 10BASE-T mode, Manchester encoding and decoding is performed on the data stream. The multimode transmit DAC performs pre-equalization for 100m of Category 3 cable.

LINK MONITOR

In 100BASE-TX mode, receive signal energy is detected by monitoring the receive pair for transitions in the signal level. Signal levels are qualified using squelch detect circuits. When no signal or certain invalid signals are detected on the receive pair, the link monitor enters and remains in the Link Fail state where only idle codes are transmitted. When a valid signal is detected on the receive pair for a minimum period of time, the link monitor enters the Link Pass state and the transmit and receive functions are enabled.

In 100BASE-FX mode, the external fiber-optic receiver performs the signal energy detection function and communicates this information directly to the BCM5228 through the differential SD± pins.

In 10BASE-T mode, a link-pulse detection circuit constantly monitors the RD± pins for the presence of valid link pulses.

CARRIER SENSE

In DTE mode, the carrier sense and receive data valid signals are multiplexed on the same pin. The carrier sense is asserted asynchronously on the CRS_DV pin as soon as valid activity is detected in the receive data stream. Loss of carrier results in the deassertion of CRS_DV synchronous to the cycle of REF_CLK that presents the first di-bit of a nibble onto RXD. If the PHY has additional bits to be presented on RXD following the initial deassertion of CRS_DV, the PHY asserts CRS_DV on cycles of REF_CLK that present the second di-bit of each nibble, and deasserts CRS_DV on cycles of REF_CLK that present the first di-bit of each nibble. If carrier sense is asserted and a valid SSD is not detected immediately, RXER is asserted. A value of 2h (2 hex) is driven on the receive data pins to indicate false carrier sense.

In 10BASE-T mode, carrier sense is asserted asynchronously on the CRS pin when valid preamble activity is detected on the RD± input pins.

AUTO-NEGOTIATION

The BCM5228 contains the ability to negotiate its mode of operation over the twisted-pair link using the auto-negotiation mechanism defined in the IEEE 802.3u specification. Auto-negotiation can be enabled or disabled by hardware or software control. When the auto-negotiation function is enabled, the BCM5228 automatically chooses its mode of operation by advertising its abilities and comparing them with those received from its link partner. The BCM5228 can be configured to advertise 100BASE-TX full-duplex and/or half-duplex and 10BASE-T full-duplex and/or half-duplex. Each transceiver negotiates independently with its link partner and chooses the highest level of operation available for its own link.

DIGITAL ADAPTIVE EQUALIZER

The digital adaptive equalizer removes interzonal interference created by the transmission channel media. The equalizer accepts sampled unequalized data from the ADC on each channel and produces equalized data. The BCM5228 achieves an optimum signal to noise ratio by using a combination of feed-forward equalization and decision-feedback equalization. This powerful technique achieves a 100BASE-TX BER of less than 1×10^{-12} for transmission up to 100 meters on Category 5 twisted-pair cable, even in harsh noise environments. The digital adaptive equalizers in the BCM5228 achieve performance close to theoretical limits. The all-digital nature of the design makes the performance very tolerant to on-chip noise. The filter coefficients are self adapting to any quality of cable or cable length. Because of transmit pre-equalization in 10BASE-T mode and complete lack of ISI in 100BASE-FX mode, the adaptive equalizer is bypassed in this mode of operation.

ADC

Each receive channel has its own 125-MHz analog to digital converter (ADC). The ADC samples the incoming data on the receive channel and produces a digital output. The output of the ADC is fed to the digital adaptive equalizer. Advanced analog circuit techniques achieve low offset, high power supply noise rejection, fast settling time, and low bit error rate (BER).

DIGITAL CLOCK RECOVERY/GENERATOR

The all-digital clock recovery and generator block creates all internal transmit and receive clocks. The transmit clocks are locked to the 50-MHz clock input, while the receive clocks are locked to the incoming data streams. Clock recovery circuits optimized to MLT3, NRZI, and Manchester encoding schemes are included for use with each of the three different operating modes. The input data streams are sampled by the recovered clock from each port and fed synchronously to the respective digital adaptive equalizer.

BASELINE WANDER CORRECTION

A 100BASE-TX data stream is not always DC balanced. Because the receive signal must pass through a transformer, the DC offset of the differential receive input can wander. This effect, known as baseline wander, can greatly reduce the noise immunity of the receiver. The BCM5228 automatically compensates for baseline wander by removing the DC offset from the

input signal, and thereby significantly reducing the chance of a receive symbol error. The baseline wander correction circuit is not required, and is therefore bypassed, in 10BASE-T and 100BASE-FX operating modes

Table 1: 4B5B Encoding

Name	4b Code	5b Code	Meaning
0	0000	11110	Data 0
1	0001	01001	Data 1
2	0010	10100	Data 2
3	0011	10101	Data 3
4	0100	01010	Data 4
5	0101	01011	Data 5
6	0110	01110	Data 6
7	0111	01111	Data 7
8	1000	10010	Data 8
9	1001	10011	Data 9
A	1010	10110	Data A
B	1011	10111	Data B
C	1100	11010	Data C
D	1101	11011	Data D
E	1110	11100	Data E
F	1111	11101	Data F
I	0000 ^a	11111	Idle
J	0101 ^a	11000	Start-of-stream delimiter, part 1
K	0101 ^a	10001	Start-of-stream delimiter, part 2
T	0000 ^a	01101	End-of-stream delimiter, part 1
R	0000 ^a	00111	End-of-stream delimiter, part 2
H	1000	00100	Transmit error (used to force signalling errors)
V	0111	00000	Invalid code
V	0111	00001	Invalid code
V	0111	00010	Invalid code
V	0111	00011	Invalid code
V	0111	00101	Invalid code
V	0111	00110	Invalid code
V	0111	01000	Invalid code
V	0111	01100	Invalid Code
V	0111	10000	Invalid Code
V	0111	11001	Invalid Code

a. Treated as invalid code (mapped to 0111) when received in data field.

MULTIMODE TRANSMIT DAC

The multimode transmit digital to analog converter (DAC) transmits MLT3-coded symbols in 100BASE-TX mode, NRZI-coded symbols in 100BASE-FX mode and Manchester-coded symbols in 10BASE-T mode. It performs programmable edge-rate control in TX mode, which decreases unwanted high frequency signal components thus reducing EMI. High-frequency



pre-emphasis is performed in 10BASE-T mode, and no filtering is performed in 100BASE-FX mode. The transmit DAC utilizes a current drive output which is well balanced and produces very low noise transmit signals. PECL voltage levels are produced with resistive terminations in 100BASE-FX mode.

STREAM CIPHER

In 100BASE-TX mode, the transmit data stream is scrambled in order to reduce radiated emissions on the twisted-pair cable. The data is scrambled by *exclusive ORing* the NRZI signal with the output of an 11-bit wide linear feedback shift register (LFSR), which produces a 2047-bit non-repeating sequence. The scrambler reduces peak emissions by randomly spreading the signal energy over the transmit frequency range, and eliminating peaks at certain frequencies. Signal energy is spread further by using unique seeds to generate a different non-repeating sequence for each of the eight ports.

The receiver descrambles the incoming data stream by *exclusive ORing* it with the same sequence generated at the transmitter. The descrambler detects the state of the transmit LFSR by looking for a sequence representing consecutive idle codes. The descrambler locks to the scrambler state after detecting a sufficient number of consecutive idle code-groups. The receiver does not attempt to decode the data stream unless the descrambler is locked. Once locked, the descrambler continuously monitors the data stream to make sure that it has not lost synchronization. The receive data stream is expected to contain inter-packet idle periods. If the descrambler does not detect enough idle codes within 724 μ s, it becomes unlocked, and the receive decoder is disabled. If the receiver is put into Token Ring mode (see bit 10, register 1Bh), the descrambler monitors the receiver for 5792 μ s before unlocking. The descrambler is always forced into the unlocked state when a link failure condition is detected. Stream cipher scrambling/descrambling is not used in 100BASE-FX and 10BASE-T modes.

FAR-END FAULT

Auto-negotiation provides a Remote Fault capability for detection of asymmetric link failures. Because auto-negotiation is not available for 100BASE-FX, the BCM5228 implements the IEEE 802.3 standard Far-End Fault mechanism for the indication and detection of remote error conditions. If the Far-End Fault mechanism is enabled, a transceiver transmits the Far-End Fault indication whenever a receive channel failure is detected (signal detect is deasserted). Each transceiver also continuously monitors the receive channel when a valid signal is present (signal detect asserted). When its link partner is indicating a remote error, the transceiver forces its link monitor into the link fail state and set the Remote Fault bit in the RMII status register. The Far-End Fault mechanism is on by default in 100BASE-FX mode, off by default in 100BASE-TX and 10BASE-T modes, and can be controlled by software after reset.

REDUCED MEDIA INDEPENDENT INTERFACE (RMII)

The interface in the BCM5228 is based on the low pin count (Reduced) Media Independent Interface (RMII) developed by the RMII Consortium. A copy of the specification can be found on the consortium Web site at:

<http://www.rmii-consort.com>. The purpose of this interface is to provide a low-cost alternative to the IEEE 802.3u[2] Media Independent Interface (MII). The RMII is capable of supporting 10 megabit and 100 megabit data rates with a single clock, using independent 2-bit wide transmit and receive paths.

A single 50-MHz synchronous reference clock is used as a timing reference for all transmitters and receivers. By doubling the clock frequency relative to the MII, four pins are saved in the data path, which uses two lines into each transmitter and two lines out of each receiver, compared to four lines used in each direction in the MII. Since start-of-packet and end-of-

packet timing information is preserved across the interface, the MAC is able to derive the COL signal from the receive and transmit data delimiters, saving another pin.

Transmit and receive clocks have been eliminated as well. All data transfers are synchronous with REF_CLK. This poses less of a challenge for the transmitter than it does for the receiver, which is now required to buffer output data in a FIFO until an edge of the REF_CLK is suitably aligned. The received data bits and the RX_DV signal are passed through the FIFO, but the CRS_DV bit is not. It is asserted for the time the wire is receiving a frame. If the remote transmitter is idle, and no data need be passed from the receiver, status information can be made available by setting Bit 1 of register 10h. Out-of-band signaling consists of 2 di-bit pairs immediately following the last di-bit pair of a received packet. The 2 di-bit pairs consist of full-duplex, Link Speed - msb, lsb and RXER, FIFO Error - msb, lsb.

MII MANAGEMENT

Management of each transceiver within the BCM5228 remains the same as it was under the MII specification. Each PHY contains an independent set of MII management registers. They share a single MDC/MDIO serial interface. Each transceiver has a unique address and must be accessed individually. The common base address for the group of eight individual transceivers is defined by configuring the five external PHYAD address input pins.

SERIAL MEDIA INDEPENDENT INTERFACE (SMII)

The SMII is an alternative to both the MII and RMII. The objective is to reduce the number of pins required to interconnect the MAC and the PHY. This is accomplished by clocking data and control signals in and out of each PHY on a pair of pins at a rate of 125 MHz. The SMII mode is selected by pulling the SMII_EN pin high during power-on reset.

Data and control signals passing from the MAC to the PHY use the serial transmit (STX) line. Data and control signals passing from the PHY to the MAC use the serial receive (SRX) line. All bit transfers are synchronous with clock (SCLK) at 125 MHz. Frame synchronization is provided by a fourth line (SYNC), asserted at the beginning of each frame, which occurs every 10 cycles of SCLK. Each PHY is provided with an STX and an SRX pair. Pins TXD0{x} and RXD0{x}, where x is the number of the specific PHY, are used to perform the STX and SRX functions.

The BCM5228 chip has a single SCLK and SYNC input that is common to all PHYs. Pins REF_CLK and SSYNC are used for these functions.

Receive data and control information are passed from the PHY to the MAC in 10 bit frames. In 100 Mbps mode, each frame represents a new byte of data. In 10 Mbps mode, each byte of data is repeated 10 times. The MAC can sample any one of every 10 frames. Since the timing of data coming from a remote transmitter is not synchronized with the local SCLK or SYNC lines and can contain errors in frequency, a FIFO capable of storing 28 bits is provided in each receive path. The received data bits and the RX_DV signal are passed through the FIFO, but the CRS bit is not. It is asserted for the time the wire is receiving a frame. If the remote transmitter is idle and no data need be passed from the receiver, status information becomes available.

Transmit data and control information are passed from the MAC to the PHY in 10 bit frames, as in the receive path. In 100 Mbps mode, each frame represents a new byte of data. In 10 Mbps mode, each byte of data is repeated 10 times, and the PHY can transmit any one of every 10 frames.

INTERRUPT MODE

The BCM5228 can be programmed to provide an interrupt output consisting of an OR of the eight interrupts, one from each PHY. The interrupt feature is disabled by default. The interrupt capability is enabled by setting MII register 1Ah, bit 14. The SLED_DO pin becomes the INTR# pin, when the SERIAL_EN is pulled low during power-up reset. If a serial LED mode is required, hardware interrupt can be obtained by wire ORing LED2{1:8} open drain outputs and programming LED2 to output interrupt by setting TXER/LED1{5:3} pins to a 5 during power-on reset. The status of each interrupt source is also reflected in register 1Ah, bits 1, 2 and 3. The sources of interrupt are change in link, speed or full-duplex status. If any type of interrupt occurs, the Interrupt Status bit, register 1Ah, bit 0 is set.

In addition, each transceiver has its own register controlling the interrupt function.

If the interrupt enable bit is set to 0, no status bits sets, and no interrupts are generated. If the interrupt enable bit is set to 1, the following conditions apply:

- If mask status bits are to 0 and the interrupt mask is set to 1, status bits are set but no interrupts are generated.
- If mask status bits are set to 0 and the interrupt mask is set to 0, status bits and interrupts are available.
- If mask status bits are set to 1 and the interrupt mask is set to 0, no status bits and no interrupts are available.

Changes from active to inactive or vice versa causes an interrupt. Setting register 1Ah, bit 8 high masks all interrupts, regardless of the settings of the individual mask bits.



Section 2: Hardware Signal Definition Table

These conventions are used in the following table:

- # = Active low
- I = Digital input
- O = Digital output
- I/O = Bidirectional
- I_A = Analog input
- O_A = Analog output
- I_{PU} = Digital input with internal pull-up
- I_{PD} = Digital input with internal pull-down
- O_{OD} = Open-drain output
- O_{3S} = Tri-state output
- I/O_{PD} = Bidirectional with internal pull-down
- B = Bias
- Bus naming convention: Pin label followed by {Port #}
- Pin type

Table 2: Pin Definitions

<i>BCM5228B</i>	<i>BCM5228F</i>	<i>BCM5228U</i>	<i>Pin Label</i>	<i>I/O</i>	<i>Description</i>
Media Connections					
A12,B12	166,167	165,166	RD+{1}, RD- {1}	I _A	Receive Pair. Differential data from the media is received on the RD± signal pair.
A11,B11	178,177	173,172	RD+{2}, RD- {2}		
A08,B08	184,185	179,180	RD+{3}, RD- {3}		
A07,B07	196,195	198,197	RD+{4}, RD- {4}		
T06,R06	64,65	62,63	RD+{5}, RD- {5}		
T07,R07	76,75	81,80	RD+{6}, RD- {6}		
T10,R10	82,83	87,88	RD+{7}, RD- {7}		
T11,R11	94,93	95,94	RD+{8}, RD- {8}		
A13,B13	164,165	163,164	TD+{1}, TD- {1}	O _A	Transmit Pair. Differential data is transmitted to the media on the TD± signal pair.
A10,B10	180,179	175,174	TD+{2}, TD- {2}		
A09,B09	182,183	177,178	TD+{3}, TD- {3}		
A06,B06	198,197	200,199	TD+{4}, TD- {4}		
T05,R05	62,63	60,61	TD+{5}, TD- {5}		
T08,R08	78,77	83,82	TD+{6}, TD- {6}		
T09,R09	80,81	85,86	TD+{7}, TD- {7}		
T12,R12	96,95	97,96	TD+{8}, TD- {8}		
D12,E12	171,170		SD+{1}, SD- {1}	I _{PD}	100BASE-FX Signal Detect. Indicates signal quality status on the fiber-optic link in 100BASE-FX mode. When the signal quality is good, the SD+ pin should be driven high relative to the SD- pin. 100BASE-FX mode is disabled when both pins are simultaneously pulled low or left unconnected.
D11,E11	173,174		SD+{2}, SD- {2}		
D08,E08	189,188		SD+{3}, SD- {3}		
E07,D07	191,192		SD+{4}, SD- {4}		
N09,M09	69,68		SD+{5}, SD- {5}		
N10,M10	71,72		SD+{6}, SD- {6}		
N11,M11	87,86		SD+{7}, SD- {7}		
N12,M12	89,90		SD+{8}, SD- {8}		
Reduced Media Independent Interface (RMII)					

Table 2: Pin Definitions (Cont.)

BCM5228B	BCM5228F	BCM5228U	Pin Label	I/O	Description
T15	99	100	REF_CLK	I	Reference Clock Input. This pin must be driven with a continuous 50-MHz clock in the RMII application and a 125-MHz clock in the SMII application. It provides timing for CRS_DV, RXD1, RXD0, TX_EN, TXD1, TXD0, and RX_ER. Accuracy shall be ± 50 ppm, with a duty cycle between 35% and 65% inclusive.
C03	4	4	TX_EN{1:8}	I _{PD}	Transmit Enable. In RMII mode, active high indicates that the MAC is presenting di-bits on TXD1, TXD0 for transmission. TX_EN is asserted synchronously with the first nibble of the preamble and remains asserted while all di-bits to be transmitted are presented to the RMII. TX_EN transitions synchronously with respect to REF_CLK.
B02	3	3			
B01	208	208			
A01	207	207			
T01	53	53			
R01	52	52			
P04	51	51			
P03	50	50			
D16	149	149	TXD1{1}	I _{PD}	Transmit Data Input. In RMII mode, TXD1, TXD0 dibit wide data is input on these pins for transmission by the PHY. The data is synchronous with REF_CLK. TXD1 is the most significant bit. Values other than 00 on TXD1, TXD0 while TX_EN is deasserted are ignored by the PHY. In SMII mode, the TXD0{1:8} form the STXD pins for each PHY.
E16	150	150			
F15	145	145			
F16	146	146			
G15	139	139			
G16	140	140			
H15	135	135			
H16	136	136			
J15	127	127			
J16	128	128			
K15	123	123			
K16	124	124			
L15	117	117			
L16	118	118			
M15	113	113			
M16	114	114			
A02	204	206	CRS_DV{1:8}	O _{3S}	Carrier Sense/Receive Data Valid. In RMII mode, CRS_DV shall be asserted by the PHY when the medium is non-idle. The data on RXD1, RXD0 is considered valid once CRS_DV is asserted. During a false carrier event, CRS_DV shall remain asserted for the duration of carrier activity. CRS_DV is not synchronized with respect to REF_CLK.
A03	203	205			
B04	202	204			
A04	201	203			
R03	59	57			
R02	58	56			
T03	57	55			
T02	56	54			
D14	151	151	RXD1{1}	O _{3S}	Receive Data Outputs. In RMII mode, RXD1, RXD0 data is output synchronous with REF_CLK. For each clock period in which CRS_DV is asserted, RXD1, RXD0 transfers 2 bits of data from the PHY. RXD1 is the most significant bit. In SMII mode, the RXD0{1:8} form the SRXD pins for each PHY.
D15	152	152			
E14	147	147			
E15	148	148			
F12	141	141			
F13	142	142			
G12	137	137			
G14	138	138			
H12	129	129			
H13	130	130			
J12	125	125			
J14	126	126			
K12	119	119			
K13	120	120			
L12	115	115			
L14	116	116			



Table 2: Pin Definitions (Cont.)

BCM5228B	BCM5228F	BCM5228U	Pin Label	I/O	Description
D02	8	8	RX_ER{1:8}	O _{3S}	Receive Error Detected. In RMII mode, RX_ER is asserted high for one or more REF_CLK periods to indicate that an error was detected somewhere in the frame presently being transferred from the PHY. RX_ER transitions synchronously with respect to REF_CLK.
D01	7	7			
C02	6	6			
C01	5	5			
N03	43	43			
M01	42	42			
M02	41	41			
L01	40	40			
Serial Media Independent Interface (SMII)					
H01	23	23	SMII_EN/SLED_CLK	I/O _{PU}	SMII Enable. Active high. An active high or being left unconnected during power-on reset selects the SMII mode, while an active low selects the RMII mode. Serial LED Clock. After power-on reset, if Serial or Low-Cost Serial LED mode is enabled, this pin sources the clock for serial data SLED_DO. For details, see "LED Modes" on page 27.
P15	105	105	SSYNC	I _{PD}	SMII SYNC. In SMII mode, this pin must be connected to a free running sync pulse occurring 1 of every 10 clock cycles. In RMII mode, this pin is NC (No Connect). Data and controls are transferred through TXD0 and RXD0 between respective MAC and PHY in default SMII mode. If source synchronous enable, SSMII_EN, is high, then SSYNC provides sync for TXD0 only and SMII_RSYNC from the BCM5228 provides sync for RXD0.
R15	103	103	SSMII_EN	I _{PD}	SMII Source Synchronous (S3MII) Enable. Active high. When S3MII is enabled, the BCM5228 provides a source synchronous receive clock (SMII_RXC) and a sync (SMII_RSYNC) for MAC to use. The BCM5228 uses SMII_TXC along with SSYNC to receive data from the MAC. Signals CRS_DV, TXER, TXEN, and RXER are not used when Source Synchronous mode is enabled.
R16	106	106	SMII_RXC	O _{3S}	SMII Source Synchronous Receive Clock. Optional 125-MHz clock in SMII mode for MAC use to clock in RXD0.
P16	107	107	SMII_RSYNC	O _{3S}	SMII Source Synchronous SYNC. In S3MII mode, this pin provides a source synchronous SYNC pulse for MAC to use for RXD0 if Source Synchronous is enabled.
T16	104	104	SMII_TXC	I _{PD}	SMII Source Synchronous Transmit Clock. 125-MHz clock in SMII mode for BCM5228 to clock in TXD0 if Source Synchronous is enabled.
Management Data I/O					
J01	32	32	MDIO	I/O _{PU}	Management Data I/O. This serial input/output bit is used to read from and write to the RMII registers. The data value on the MDIO pin is valid and latched on the rising edge of MDC.
K01	31	31	MDC	I _{PD}	Management Data Clock. The MDC clock input must be provided to allow RMII management functions. Clock frequencies up to 25 MHz are supported.
G05	24	24	PHYAD{4:0}	I _{PD}	PHY Address Selects. These inputs set the base address for MII management PHY addresses. Also serve as test control inputs along with TESTEN to select the NAND-chain test mode.
H05	25	25			
H04	26	26			
J05	27	27			
J03	28	28			

Table 2: Pin Definitions (Cont.)

BCM5228B	BCM5228F	BCM5228U	Pin Label	I/O	Description
H02	22	22	MASTERPHY/SFRAME	I/O _{PD}	<p>Master PHY Address Mode. Active high. This forces PHY address 0 to be a global write address for all PHYs within the BCM5228. An active high during power-on reset selects the master PHY address mode, while an active low or being left unconnected selects the normal address mode.</p> <p>Serial LED Frame. After power-on reset, this pin sources the serial LED frame output signal if serial LED mode is enabled.</p>
Mode					
C16	157	157	RESET#	I _{PU}	Reset. Active Low. Resets the BCM5228. Pin not included in NAND chain.
N15	109	109	F100	I _{PU}	10/100 Mode Select. When high and ANEN is low, all transceivers are forced to 100BASE-X operation. When low and ANEN is low, all transceivers are forced to 10BASE-T operation. When ANEN is high, F100 has no effect on the operation.
M13	108	108	ANEN	I _{PU}	Auto-Negotiation Enable. Active high. When pulled high, auto-negotiation begins immediately after reset. When low, auto-negotiation is disabled after reset. Auto-negotiation can be enabled under software control (register 0, bit 12) if auto-negotiation is enabled through hardware.
C15	156	156	FDXEN	I _{PD}	Full-Duplex Mode Enable. The FDXEN pin is logically ORed with an MII control bit to generate an internal full-duplex enable signal. When FDXEN is high, the BCM5228 can operate in full-duplex mode as determined by auto-negotiation. When FDXEN is low, the internal control bit (register 0, bit 8) determines the full-duplex operating mode. Initial value of the internal control bit is zero.
G01	19	19	TXER_EN	I/O _{PU}	TXER Enable. Active high. When pulled high during power-on reset, TXER[1:8]/LED1[1:8] pins become TXER[1:8] input. Otherwise they become LED1[1:8] output.
F05	20	20	MDIX_DIS	I/O _{PD}	HP Auto-MDIX Disable. Active high. When pulled high during reset, automatic TX cable swap detection function of the BCM5228 is disabled. Leave this pin unconnected for normal operation.
F04	17	17	TESTEN	I _{PD}	Test Enable. Active high test control input used along with PHYAD[4:0] to select the NAND-chain test mode. This test mode is latched when TESTEN is pulsed high, then low, with PHYAD[4:0]=10111. This pin is not included in the NAND chain and must be pulled low or left unconnected during normal operation.
LED					
G03	21	21	SERIAL_EN	I/O _{PD}	<p>Serial LED Enable. Active high. Serial LED mode is enabled if this pin is high and the LC-SER_EN pin is low during power-on reset. Serial LED mode and Low-Cost Serial LED mode cannot be active at the same time.</p> <p>For details, see “LED Modes” on page 27.</p>
G02	18	18	LC_SER_EN	I/O _{PU}	<p>Low-Cost Serial LED Enable. Active high. Low-Cost Serial LED mode is enabled if this pin is high and SER_EN pin is high during power-on reset. Low-Cost Serial LED mode and Serial LED mode can not be active at the same time.</p> <p>For details, see “LED Modes” on page 27.</p>

Table 2: Pin Definitions (Cont.)

BCM5228B	BCM5228F	BCM5228U	Pin Label	I/O	Description
K02	30	30	SLED_DO/INTR#	O _{OD}	Serial LED Data. Active low serial LED data. This pin becomes serial LED data output if SER_EN pin is high during power-on reset. For details, see “LED Modes” on page 27. PHY Interrupt. Active low output. This pin becomes interrupt output if SER_EN pin is low during power-on reset.
F01	12	12	TX_ER{1:8} LED1{1:8}	I/O _{PD}	TXER[1:8]. Active high input. This pin becomes TXER input if TXER_EN pin is high during power-on reset. TXER function is typically used in HSTR application for transmitting halt codes. TXER[1:8] pins are sampled during power-on reset to set the default LED output for LED1, LED2 and LED3. For details, see “LED Modes” on page 27. LED1[1:8]. Active low output. This pin becomes LED1 output if TXER_EN pin is low during power-on reset. LED1 can be configured to output one of LINK, SPEED, ACTIVITY, FULL-DUPLEX, TRANSMIT, RECEIVE, INTERRUPT or COLLISION status. For details, see “LED Modes” on page 27.
F02	11	11			
E01	10	10			
E02	9	9			
P01	47	47			
P02	46	46			
N02	45	45			
N01	44	44			
C04		185	LED2{1:8}	O _{OD}	LED2. Active low. This pin can be configured to output one of SPEED, ACTIVITY, FULL-DUPLEX, TRANSMIT, RECEIVE, INTERRUPT, COLLISION, or LINK status. For details, see “LED Modes” on page 27.
E06		186			
D05		187			
C05		188			
M07		68			
N07		69			
M06		70			
N06		71			
D03		189	LED3{1:8}	O _{3S}	LED3. Active low. The function of this LED signal can be configured to output one of ACTIVITY, FULL-DUPLEX, LINK or SPEED status. For details, see “LED Modes” on page 27.
B03		190			
E05		191			
D04		192			
M05		72			
N04		73			
N05		74			
M04		75			
Bias					
A15	161	160	RDAC	B	DAC Bias Resistor. Adjusts the current level of each of the transmit DAC's. A resistor of 1.24-k Ω \pm 1% must be connected between the RDAC pin and AGND.
A14	162	161	VREF	B	Voltage Reference. Low-impedance bias pin driven by the internal band-gap voltage reference. This pin must be left unconnected during normal operation.
JTAG					
L02	37	37	TDI	I _{PU}	Test Mode Select. Serial data input to the JTAG TAP controller. Sampled on the rising edge of TCK. If unused, it can be left unconnected.
L03	35	35	TMS	I _{PU}	Test Data Input. Single control input to the JTAG TAP controller used to traverse the test-logic state machine. Sampled on the rising edge of TCK. If unused, it can be left unconnected.
L05	36	36	TCK	I _{PU}	Test Clock. Clock input used to synchronize the JTAG TAP control and data transfers. If unused, it can be left unconnected.
K04	33	33	TDO	O _{3S}	Test Data Output. Serial data output from the JTAG TAP Controller. Updated on the falling edge of TCK. Actively driven both high and low when enabled, otherwise high impedance.

Table 2: Pin Definitions (Cont.)

BCM5228B	BCM5228F	BCM5228U	Pin Label	I/O	Description
K05	34	34	TRST#	I _{PU}	Test Reset. Asynchronous active-low reset input to the JTAG TAP Controller. Must be held low during power-up to insure the TAP Controller initializes to the test-logic-reset state. Can be pulled low continuously when JTAG functions are not used. Must be held low for normal operation.
Power					
T14	101	102	PLLVDCC		2.5-V, Phase Locked Loop VDD Core, DVDD
R14	98	99	PLLGND		Phase Locked Loop GND
P14	100	101	PLLVDDP		PLL PAD VDD. Tie this to the same supply as OVDD.
A16	160	159	BIASVDD		2.5-V, Bias VDD
B16	163	162	BIASGND		Bias GND
A05	67	65	AVDD		2.5-V, Analog VDD
C07	73	78			
C10	85	90			
C13	91	92			
P07	169	168			
P11	175	170			
T04	187	182			
T13	193	195			
B05	61	59	AGND		Analog GND
B14	66	64			
B15	70	66			
C06	74	77			
C08	79	79			
C09	84	84			
C11	88	89			
C12	92	91			
D09	97	93			
D10	168	98			
E09	172	167			
P05	176	169			
P06	181	171			
P08	186	176			
P09	190	181			
P10	194	183			
P12	199	194			
P13		196			
R04		201			
R13					
E04	2	2	DVDD		2.5-V, Digital Core VDD
E13	15	15			
G04	48	48			
K14	111	111			
L04	132	132			
N13	154	154			
C14	1	1	DGND		Digital Core GND
F03	14	14			
G06	49	49			
J13	110	110			
M03	133	133			
N14	155	155			



Table 2: Pin Definitions (Cont.)

BCM5228B	BCM5228F	BCM5228U	Pin Label	I/O	Description
D06	13	13	OVDD		3.3V, Digital Periphery (Output Buffer) VDD
E03	16	16			
F14	39	39			
G13	121	67			
H03	122	121			
K03	143	122			
L13	144	143			
M14		144			
N08		184			
D13	38	38	OGND		Digital Periphery (Output Buffer) GND
F06	60	58			
F07	112	76			
H11	131	112			
H14	134	131			
J04	153	134			
L06	200	153			
L07		193			
N16		202			



Section 3: Pinout Diagrams

The pinout diagram for the BCM5228F (FX Support) is illustrated on [Figure 2](#).

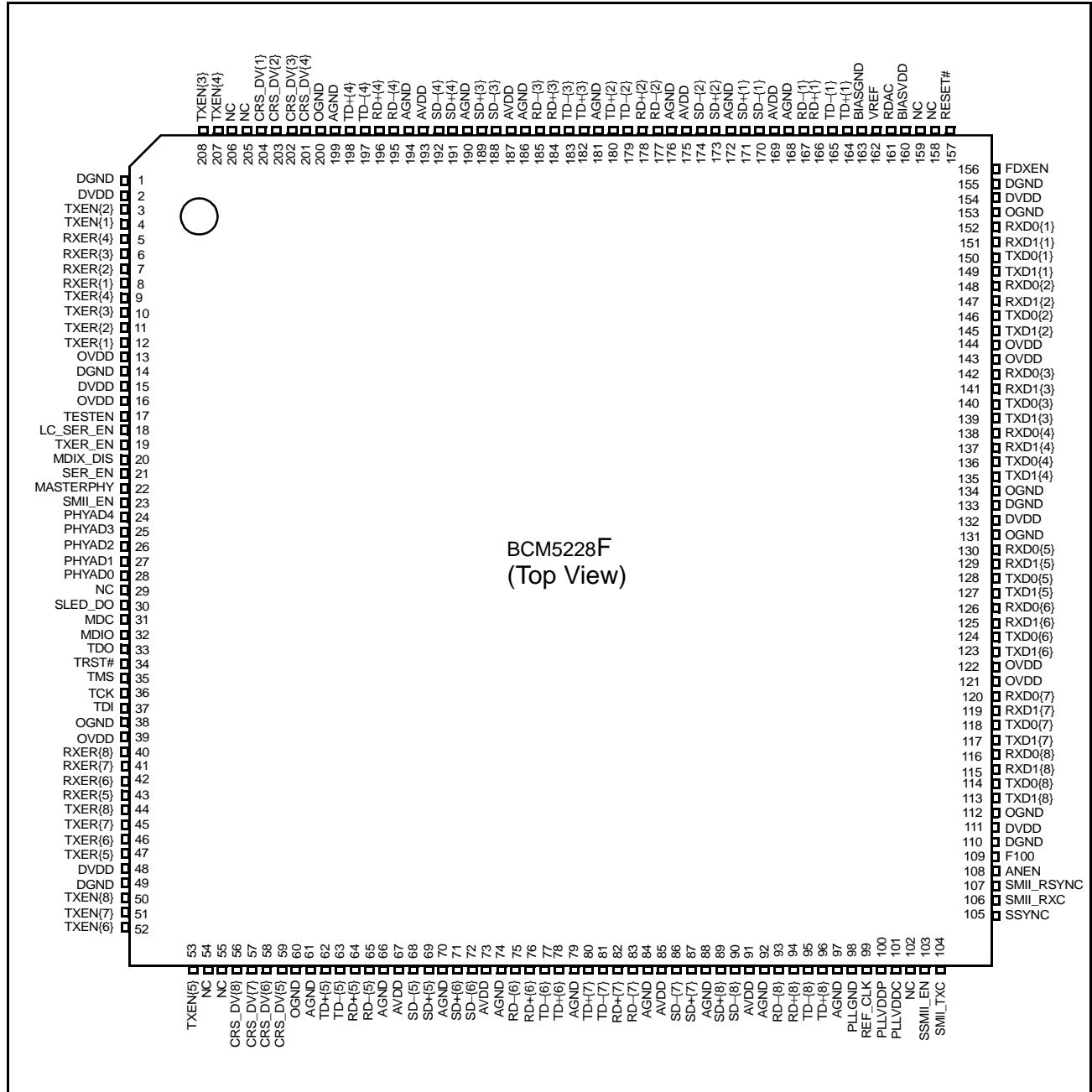

Figure 2: BCM5228F Pinout Diagram

The pinout diagram for the BCM5228U (UTP Support) is illustrated on [Figure 3 on page 18](#).

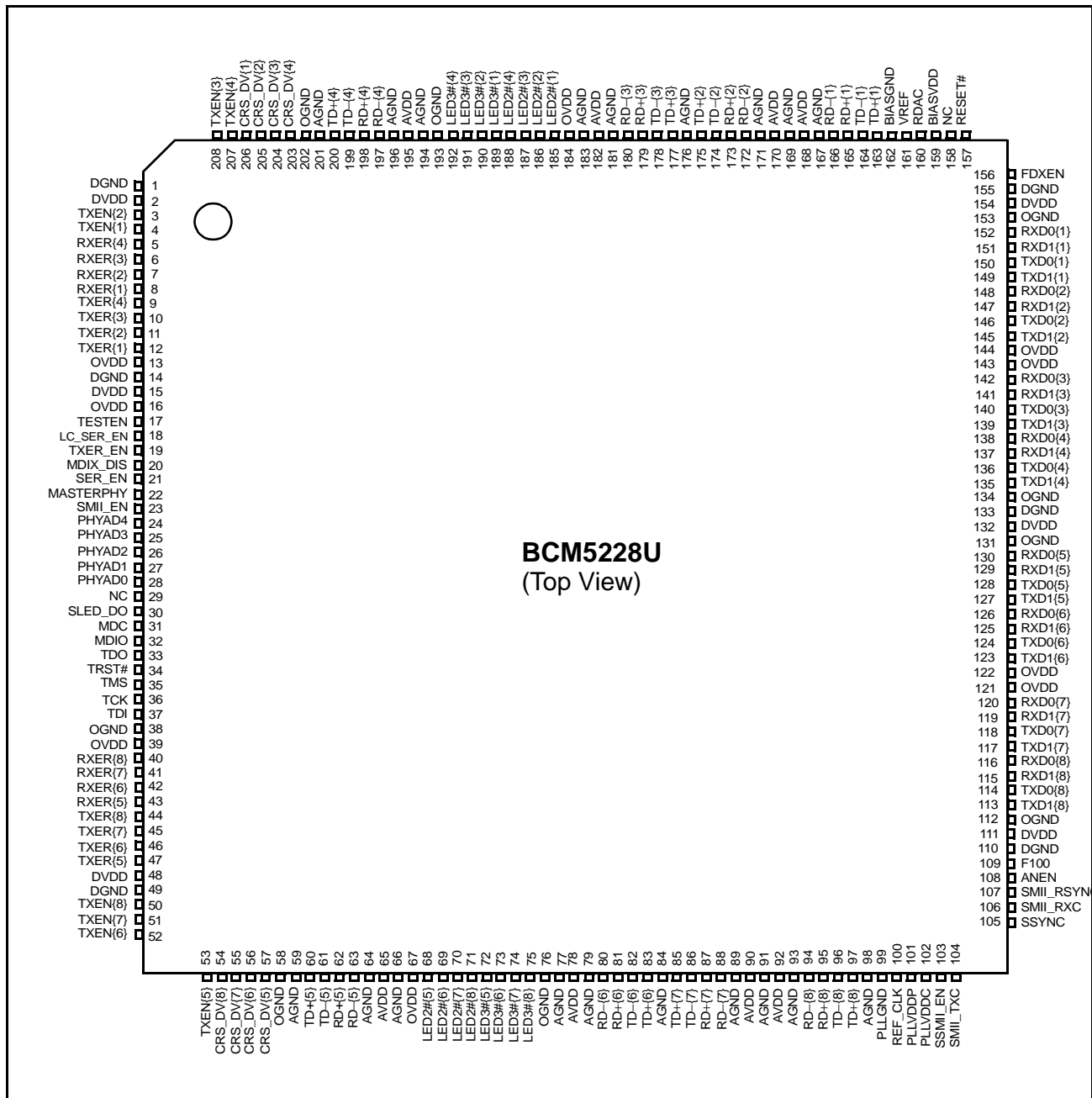

Figure 3: BCM5228U Pinout Diagram



	01	02	03	04	05	06	07	08	09	10	11	12	13	14
A	TXEN{4}	CRS_DV{1}	CRS_DV{2}	CRS_DV{4}	AVDD	TD+{4}	RD+{4}	RD+{3}	TD+{3}	TD+{2}	RD+{2}	RD+{1}	TD+{1}	VR
B	TXEN{3}	TXEN{2}	LED3{2}	CRS_DV{3}	AGND	TD-{4}	RD-{4}	RD-{3}	TD-{3}	TD-{2}	RD-{2}	RD-{1}	TD-{1}	AG
C	RXER{4}	RXER{3}	TXEN{1}	LED2{1}	LED2{4}	AGND	AVDD	AGND	AGND	AVDD	AGND	AGND	AVDD	DG
D	RXER{2}	RXER{1}	LED3{1}	LED3{4}	LED2{3}	OVDD	SD-{4}	SD+{3}	AGND	AGND	SD+{2}	SD+{1}	OGND	RXD
E	TX_ER{3}/LED1{3}	TX_ER{4}/LED1{4}	OVDD	DVDD	LED3{3}	LED2{2}	SD+{4}	SD-{3}	AGND	NC	SD-{2}	SD-{1}	DVDD	RXD
F	TX_ER{1}/LED1{1}	TX_ER{2}/LED1{2}	DGND	TESTEN	MDIX_DIS	OGND	OGND	TGND	TGND	TGND	TGND	RXD1{3}	RXD0{3}	OV
G	TXER_EN	LC_SER_EN	SERIAL_EN	DVDD	PHYAD4	DGND	TGND	TGND	TGND	TGND	TGND	RXD1{4}	OVDD	RXD
H	SMIL_EN/SLED_CLK	MASTERPHY/SFRAME	OVDD	PHYAD2	PHYAD3	TGND	TGND	TGND	TGND	TGND	OGND	RXD1{5}	RXD0{5}	OG
J	MDIO	NC	PHYAD0	OGND	PHYAD1	TGND	TGND	TGND	TGND	TGND	TGND	RXD1{6}	DGND	RXD
K	MDC	SLED_DO/INTR#	OVDD	TDO	TRST#	TGND	TGND	TGND	TGND	TGND	TGND	RXD1{7}	RXD0{7}	DV
L	RXER{8}	TDI	TMS	DVDD	TCK	OGND	OGND	TGND	TGND	TGND	TGND	RXD1{8}	OVDD	RXD
M	RXER{6}	RXER{7}	DGND	LED3{8}	LED3{5}	LED2{7}	LED2{5}	NC	SD-{5}	SD-{6}	SD-{7}	SD-{8}	ANEN	PLL
N	TX_ER{8}/LED1{8}	TX_ER{7}/LED1{7}	RXER{5}	LED3{6}	LED3{7}	LED2{8}	LED2{6}	OVDD	SD+{5}	SD+{6}	SD+{7}	SD+{8}	DVDD	DG
P	TX_ER{5}/LED1{5}	TX_ER{6}/LED1{6}	TXEN{8}	TXEN{7}	AGND	AGND	AVDD	AGND	AGND	AGND	AVDD	AGND	AGND	PLL
R	TXEN{6}	CRS_DV{6}	CRS_DV{5}	AGND	TD-{5}	RD-{5}	RD-{6}	TD-{6}	TD-{7}	RD-{7}	RD-{8}	TD-{8}	AGND	PLL

Figure 4: BGA Pinout (Top View)

Table 3: BGA Ballout by Signal Name

Signal Name	Ball	Signal Name	Ball	Signal Name	Ball
AGND	B05	CRS_DV{5}	R03	MASTERPHY/SFRAME	H02
AGND	B14	CRS_DV{6}	R02	MDC	K01
AGND	B15	CRS_DV{7}	T03	MDIO	J01
AGND	C06	CRS_DV{8}	T02	MDIX_DIS	F05
AGND	C08	DGND	C14	NC	E10
AGND	C09	DGND	F03	NC	J02
AGND	C11	DGND	G06	NC	M08
AGND	C12	DGND	J13	OGND	D13
AGND	D09	DGND	M03	OGND	F06
AGND	D10	DGND	N14	OGND	F07
AGND	E09	DVDD	E04	OGND	H11
AGND	P05	DVDD	E13	OGND	H14
AGND	P06	DVDD	G04	OGND	J04
AGND	P08	DVDD	K14	OGND	L06
AGND	P09	DVDD	L04	OGND	L07
AGND	P10	DVDD	N13	OGND	N16
AGND	P12	F100	N15	OVDD	D06
AGND	P13	FDXEN	C15	OVDD	E03
AGND	R04	LC_SER_EN	G02	OVDD	F14
AGND	R13	LED2{1}	C04	OVDD	G13
ANEN	M13	LED2{2}	E06	OVDD	H03
AVDD	A05	LED2{3}	D05	OVDD	K03
AVDD	C07	LED2{4}	C05	OVDD	L13
AVDD	C10	LED2{5}	M07	OVDD	M14
AVDD	C13	LED2{6}	N07	OVDD	N08
AVDD	P07	LED2{7}	M06	PLLVDPP	P14
AVDD	P11	LED2{8}	N06	PHYAD0	J03
AVDD	T04	LED3{1}	D03	PHYAD1	J05
AVDD	T13	LED3{2}	B03	PHYAD2	H04
BIASGND	B16	LED3{3}	E05	PHYAD3	H05
BIASVDD	A16	LED3{4}	D04	PHYAD4	G05
CRS_DV{1}	A02	LED3{5}	M05	PLLGND	R14
CRS_DV{2}	A03	LED3{6}	N04	PLLVDCC	T14
CRS_DV{3}	B04	LED3{7}	N05	RD-{1}	B12
CRS_DV{4}	A04	LED3{8}	M04	RD-{2}	B11

Table 3: BGA Ballout by Signal Name (Cont.)

Signal Name	Ball	Signal Name	Ball	Signal Name	Ball
RD-{3}	B08	RXER{4}	C01	TD-{7}	R09
RD-{4}	B07	RXER{5}	N03	TD-{8}	R12
RD-{5}	R06	RXER{6}	M01	TD+{1}	A13
RD-{6}	R07	RXER{7}	M02	TD+{2}	A10
RD-{7}	R10	RXER{8}	L01	TD+{3}	A09
RD-{8}	R11	SD-{1}	E12	TD+{4}	A06
RD+{1}	A12	SD-{2}	E11	TD+{5}	T05
RD+{2}	A11	SD-{3}	E08	TD+{6}	T08
RD+{3}	A08	SD-{4}	D07	TD+{7}	T09
RD+{4}	A07	SD-{5}	M09	TD+{8}	T12
RD+{5}	T06	SD-{6}	M10	TDI	L02
RD+{6}	T07	SD-{7}	M11	TDO	K04
RD+{7}	T10	SD-{8}	M12	TESTEN	F04
RD+{8}	T11	SD+{1}	D12	TGND	F08
RDAC	A15	SD+{2}	D11	TGND	F09
REF_CLK	T15	SD+{3}	D08	TGND	F10
RESET#	C16	SD+{4}	E07	TGND	F11
RXD0{1}	D15	SD+{5}	N09	TGND	G07
RXD0{2}	E15	SD+{6}	N10	TGND	G08
RXD0{3}	F13	SD+{7}	N11	TGND	G09
RXD0{4}	G14	SD+{8}	N12	TGND	G10
RXD0{5}	H13	SERIAL_EN	G03	TGND	G11
RXD0{6}	J14	SLED_DO/INTR#	K02	TGND	H06
RXD0{7}	K13	SMII_RS SYNC	P16	TGND	H07
RXD0{8}	L14	SMII_RXC	R16	TGND	H08
RXD1{1}	D14	SMII_TXC	T16	TGND	H09
RXD1{2}	E14	SMII_EN/SLED_CLK	H01	TGND	H10
RXD1{3}	F12	SSMII_EN	R15	TGND	J06
RXD1{4}	G12	SSYNC	P15	TGND	J07
RXD1{5}	H12	TCK	L05	TGND	J08
RXD1{6}	J12	TD-{1}	B13	TGND	J09
RXD1{7}	K12	TD-{2}	B10	TGND	J10
RXD1{8}	L12	TD-{3}	B09	TGND	J11
RXER{1}	D02	TD-{4}	B06	TGND	K06
RXER{2}	D01	TD-{5}	R05	TGND	K07
RXER{3}	C02	TD-{6}	R08	TGND	K08

Table 3: BGA Ballout by Signal Name (Cont.)

Signal Name	Ball	Signal Name	Ball	Signal Name	Ball
TGND	K09	TXD0{7}	L16	TXEN{6}	R01
TGND	K10	TXD0{8}	M16	TXEN{7}	P04
TGND	K11	TXD1{1}	D16	TXEN{8}	P03
TGND	L08	TXD1{2}	F15	TXER_EN	G01
TGND	L09	TXD1{3}	G15	TX_ER{1}/LED1{1}	F01
TGND	L10	TXD1{4}	H15	TX_ER{2}/LED1{2}	F02
TGND	L11	TXD1{5}	J15	TX_ER{3}/LED1{3}	E01
TMS	L03	TXD1{6}	K15	TX_ER{4}/LED1{4}	E02
TRST#	K05	TXD1{7}	L15	TX_ER{5}/LED1{5}	P01
TXD0{1}	E16	TXD1{8}	M15	TX_ER{6}/LED1{6}	P02
TXD0{2}	F16	TXEN{1}	C03	TX_ER{7}/LED1{7}	N02
TXD0{3}	G16	TXEN{2}	B02	TX_ER{8}/LED1{8}	N01
TXD0{4}	H16	TXEN{3}	B01	VREF	A14
TXD0{5}	J16	TXEN{4}	A01		
TXD0{6}	K16	TXEN{5}	T01		



Section 4: Operational Description

RESETTING THE BCM5228

There are two ways to reset each transceiver in the BCM5228. A hardware reset pin has been provided which resets all internal nodes inside the chip to a known state. The reset pulse must be asserted for at least 2 μ s. Hardware reset should always be applied to a BCM5228 after power-up and after all clocks to the chip are running.

Each transceiver in the BCM5228 also has an individual software reset capability. To perform software reset, a 1 must be written to bit 15 of the MII Control register 0 (see "[MII Register Map Summary](#)" on page 35) of the transceiver. This bit is self-clearing, meaning that a second write operation is not necessary to end the reset. There is no effect if a 0 is written to this bit.

LOOPBACK MODE

The loopback mode allows in-circuit testing of the BCM5228 chip. All packets sent in through the TXD pins are looped-back internally to the RXD pins, and are not sent out to the cable. Incoming packets on the cable are ignored.

The loopback mode can be entered by writing a 1 to bit 14 of the MII Control register or by writing a 1 to bit 8 and bit 7 of shadow register 1Dh. In order to resume normal operation the bits must be 0.

Several function bypass modes are also supported which can provide a number of different combinations of feedback paths during loopback testing. These bypass modes include: bypass scrambler, bypass MLT3 encoder and bypass 4B5B encoder.

FULL-DUPLEX MODE

The BCM5228 supports full-duplex operation. While in full-duplex mode, a transceiver can simultaneously transmit and receive packets on the cable. By default, each transceiver in the BCM5228 powers up in half-duplex mode.

When auto-negotiation is disabled, full-duplex operation can be enabled either by a pin (FDXEN) or by an MII register bit (register 0 bit 8).

When auto-negotiation is enabled in DTE mode, full-duplex capability is advertised by default but can be overridden by a write to the auto-negotiation Advertisement register (04h).

100BASE-FX MODE

Any of the BCM5228F transceivers can interface with an external 100BASE-FX fiber-optic driver and receiver instead of the magnetics module used with twisted-pair cable. The differential transmit and receive data pairs operate at PECL voltage levels instead of those required for twisted-pair transmission, if the termination scheme recommended in the application note

is used. The data is encoded using two-level NRZI instead of three-level MLT3. The data stream is not scrambled for fiber-optic transmission. The stream cipher function is bypassed when 100BASE-FX mode is selected.

The external fiber-optic receiver detects signal status and communicate it to the BCM5228B or BCM5228F through the SD_{\pm} pins. In this mode, the internal signal detect function is bypassed. The 100BASE-FX mode is automatically selected whenever a valid differential signal is detected at the SD_{\pm} input pins. Pulling both $SD+$ and $SD-$ low simultaneously disables the 100BASE-FX mode.

10BASE-T MODE

The same magnetics module is used to interface the twisted-pair cable in 10BASE-T mode and in 100BASE-TX mode. The data is two-level Manchester coded instead of three-level MLT3 and no scrambling/descrambling or 4B5B coding is performed.

Data and clock rates are decreased by a factor of 10, with the RMII interface operating at 2.5 MHz.

ISOLATE MODE

Each transceiver in the BCM5228 can be isolated from the RMII/SMII/S3MII interface. When a transceiver is put into isolate mode, all RMII/SMII/S3MII input pins (TXD0, TXD1, TX_EN, TX_ER, SSYNC, SMII_TXC) are ignored and all RMII/SMII/S3MII output pins (CRS_DV, RX_ER, RXD0, RXD1, SMII_RSYNC, SMII_RXC) are set at high impedance. MII management pins (MDC, MDIO,) and analog TD_{\pm} , RD_{\pm} pins operate normally. Writing a 1 to bit 10 of the MII Control register 0 puts the port into isolate mode. Writing a 0 to the same bit removes it from isolate mode. Upon resetting the chip or resetting the isolated port, the isolate mode is off.

SUPER ISOLATE MODE

When the chip is in super isolate mode, in addition to isolate mode actions, the chip also sets the analog TD_{\pm} pins to high impedance. Writing a 1 to bit 3 of the MII register 1Eh puts the port into super isolate mode. Writing a 0 to the same bit removes it from super isolate mode. Upon resetting the chip or resetting the isolated port, the super isolate mode is off.

AUTO POWER-DOWN MODE

The BCM5228 supports a low power mode called auto power-down mode. Auto power-down mode is enabled by setting bit 5 of shadow register 1Bh. When in this mode, the BCM5228 automatically enters the low power mode if the energy from the link partner is lost. Similarly, the next time energy is detected, the chip resumes full power mode. When the BCM5228 is in this low power mode, it wakes up after approximately 2.5 to 5.0 seconds, as determined by bit 4 of shadow register 1Bh, and sends a link pulse while monitoring energy from the link partner. If energy is detected, the BCM5228 enters full power mode and establishes link with the link partner. Otherwise, the wake-up mode continues for a duration of approximately 40–600 milliseconds, as determined by bits [3:0] of shadow register 1Bh before going to low power mode. See [Table 43 on page 63](#) for details of various bits.

JUMBO PACKET MODE

In 100BASE-X mode, the BCM5228 can support jumbo packet size. The size of the packet that can be handled reliably depends on the descrambler lock timer settings and the receive FIFO size. By default, the BCM5228 provides an effective 10 bits of receive FIFO to allow for extremely large packet sizes. These modes are enabled by setting appropriate bits in the MII registers. Table 4 shows the number of effective FIFO bits supported.

Table 4: Receive FIFO Size Select

Jumbo Packet FIFO Enable Reg 1Bh bit 9	Extended FIFO Enable Reg 10h bit 2	Number of Effective FIFO Bits Supported	Packet Size (bytes^b)
0	0	10	12 500
0	1	20	25 000
1	0	20	25 000
1	1	40 (20 ^a)	50 000/25 000

- a. In this mode, the BCM5228 operation is guaranteed to only 20 bits of effective FIFO depth, although under some circumstances, it could behave as if the FIFO depth is 40 bits.
- b. The packet size calculation is based on 50 ppm clock tolerance for local and link partner.

When changing the receive FIFO size, it is necessary to identify the receive packet size requirement and set the descrambler timer lock accordingly. The descrambler lock is controlled by the Jumbo Packet Enable bit located in register 1HBh, bit 10.

Table 5: Jumbo Packet Enable and Descrambler Lock Timer

Jumbo Packet Enable Reg 1Bh bit 10	Descrambler Lock Timer	Packet Size
0	720 μ s	9050
1	5792 μ s	72 400

The packet size that can be reliably received is the lower number indicated by two settings: the Jumbo Packet Enable bit and the two Extended FIFO Enable bits.

PHY ADDRESS

Each transceiver in the BCM5228 has a unique PHY address for MII management. The PHY address is determined by the using the base address, which is input on the PHYAD[4:0] pins. The following shows the addressing of the eight PHYs.

$$\text{PHY0} = \text{PHYAD} + 0, \text{PHY1} = \text{PHYAD} + 1, \dots, \text{PHY7} = \text{PHYAD} + 7$$

Every time an MII write or read operation is executed, the transceiver compares the PHY address with its own PHY address definition. The operation is executed only when the addresses match.

HP AUTO-MDIX

During auto-negotiation and in various operating modes, one end of the link must be configured as an MDI (Media Independent Interface) crossover so that each transceiver's transmitter is connected to the other's receiver. The BCM5228 contains the ability to perform HP Auto-MDIX crossover, thus eliminating the need for crossover cable or cross-wired (MDIX) ports.

During auto-negotiation and in various operating modes, the BCM5228 normally transmits on TD± and receives on RD±. When connected via a straight-through cable to another device that does not have HP Auto-MDIX, the BCM5228 automatically switches its transmitter to RD± and its receiver to TD± to communicate with that device. If the link partner also has HP Auto-MDIX, then a random algorithm determines which end performs the crossover function.

The HP Auto-MDIX feature is implemented in accordance with the IEEE 802.3ab specification. The HP Auto-MDIX crossover feature is a function of auto-negotiation. Therefore, if the BCM5228 is configured not to perform auto-negotiation, HP Auto-MDIX crossover does not work, and a specific cable is required to ensure that each transceiver's transmitter is connected to the other's receiver.

The HP Auto-MDIX feature is enabled in hardware by pulling the MDIX_DIS pin low during power-on reset. If enabled by hardware, this feature can be disabled by setting bit 11 of the MII register 1Ch to 0.

Section 5: LED Modes

DESCRIPTION

The BCM5228 offers a rich set of LED display outputs through serial and parallel LED modes. There are two serial LED modes available, Serial LED mode and Low-Cost Serial LED mode. The serial LED mode provides compatibility with few other Broadcom PHYs. Serial LED modes are selected by hardware only during power-on reset. When any serial LED mode is enabled global hardware interrupt feature is not available. However, if interrupt and a serial or a Low-Cost Serial LED mode is desired simultaneously, then a parallel LED can be programmed to provide on interrupt output per port and eight such interrupt can be ORed to obtain a global interrupt.

SERIAL LED MODE

The Serial LED mode is enabled only by having the SER_EN pin high and the LC_SER_EN pin low during power-on reset. If Serial LED mode is enabled, then the Low-cost Serial LED mode and hardware global interrupt are disabled. In Serial LED mode, the BCM5228 sources a serial data stream, the associated clock, and a framing signal as follows:

- Serial data stream, SLED_DO, which is an active low bit stream containing 48 bits per frame.
- Serial data clock, SLED_CLK, is used to clock out SLED_DO on the falling edge of this clock. SLED-DO is valid on the rising edge of this clock. SLED_CLK is approximately 3.125 MHz in forced 100BASE-T and -FX modes, and 2.5 MHz in all other modes.
- Framing pulse, SFRAME, which is a logic high pulse occurring once every 48 SLED_DO bit times. SFRAME goes high coincident with bit 0 of port 1.

When the serial LED mode is enabled by hardware, the LED stream is selected for SLED_DO as shown in Table 6, depending on the values of bits 14 and 15 of MII register 1Ah. The data stream contains bit 0 to bit 5 for port 1, bit 0 to bit 5 for port 2, ... and bit 0 to bit 5 for port 8.

Table 6: Serial LED Mode Bit Framing

Reg 1Ah		Serial Bit 5	Serial Bit 4	Serial Bit 3	Serial Bit 2	Serial Bit 1	Serial Bit 0
Bit 15 = 0	Bit 14 = 0	FDX	COL	Speed100	Link	Transmit	Receive
Bit 15 = 0	Bit 14 = 1	FDX	Global Interrupt	Speed100	Link	Port Interrupt	Activity
Bit 15 = 1	Bit 14 = 0	FDX	COL	Speed100	Link	FDX	Activity
Bit 15 = 1	Bit 14 = 1	FDX	Global Interrupt	Speed100	Link	FDX	Activity

NOTE—A global interrupt indicates an interrupt from any of the eight PHYs as if they were ORed together. A port interrupt is provided on a per-PHY basis.

LOW-COST SERIAL LED MODE

The low-cost serial LED mode is enabled by pulling both LC_SER_EN pin and SER_EN pin high during power-on reset. When enabled, serial LED data stream, SLED_DO, is shifted out on the falling edge of SLED_CLK. SLED_DO is valid on the rising edge of this clock. The data is shifted in such a manner that the update of LEDs using a simple shift register that drive the display LEDs do not cause noticeable flicker in normal operation.

There are six banks, bank 1 through bank 6, associated with six LED outputs. Each bank has its own MII register bits that select LED a signal to output from that bank. The selected signal from each bank is shifted out on the LED_DO pin in the following order for a total of 48 LED outputs:

- Bank 1 for port 1 through port 8
- Bank 2 for port 1 through port 8,...
- Bank 6 for port 1 through 8

The low-cost serial LED mode programmable banks are located in the MII shadow register 1Ah of port 2 and port 3. For programming details, see [Table 7](#), [Table 8](#), [Table 9](#), [Table 10](#), [Table 11](#), and [Table 12](#). The default LED outputs are Speed, Link, Full-duplex, Activity, Speed, and Link for bank 1 through bank 6, respectively.

Table 7: Low-Cost Serial Mode Bank 1 LED Selection

<i>MII Shadow Register^a 1Ah, PHY 3, Bits [2:0]</i>	<i>Value</i>	<i>LED Selection</i>
SERIAL BANK 1 SELECT BITS[2:0]	0	Speed
	1	Activity
	2	Full-duplex
	3	Transmit
	4	Receive
	5	Interrupt
	6	Collision
	7	Link

a. The MII Shadow register is accessed by setting MII register 1Fh bit 7 to 1.

Table 8: Low-Cost Serial Mode Bank 2 LED Selection

<i>MII Shadow Register^a 1Ah, PHY 3, Bits [5:3]</i>	<i>Value</i>	<i>LED Selection</i>
SERIAL LED BANK 2 SELECT BITS[2:0]	0	Link
	1	Speed
	2	Activity
	3	Full-duplex
	4	Transmit
	5	Receive
	6	Interrupt
	7	Collision

a. The MII Shadow register is accessed by setting MII register 1Fh bit 7 to 1.



Table 9: Low-Cost Serial Mode Bank 3 LED Selection

<i>MII Shadow Register^a 1Ah, PHY 3, Bits [8:6]</i>	<i>Value</i>	<i>LED Selection</i>
SERIAL LED BANK 3 SELECT BITS[2:0]	0	Full-duplex
	1	Transmit
	2	Receive
	3	Interrupt
	4	Collision
	5	Link
	6	Speed
	7	Activity

a. The MII Shadow register is accessed by setting MII register 1Fh bit 7 to 1.

Table 10: Low-Cost Serial Mode Bank 4 LED Selection

<i>MII Shadow Register^a 1Ah, PHY 2, Bits [2:0]</i>	<i>Value</i>	<i>LED Selection</i>
SERIAL LED BANK 4 SELECT BITS[2:0]	0	Activity
	1	Full-duplex
	2	Transmit
	3	Receive
	4	Interrupt
	5	Collision
	6	Link
	7	Speed

a. The MII Shadow register is accessed by setting MII register 1Fh bit 7 to 1.

Table 11: Low-Cost Serial Mode Bank 5 LED Selection

<i>MII Shadow Register^a 1Ah, PHY 2, Bits [5:3]</i>	<i>Value</i>	<i>LED Selection</i>
SERIAL LED BANK 5 SELECT BITS[2:0]	0	Speed
	1	Activity
	2	Full-duplex
	3	Transmit
	4	Receive
	5	Interrupt
	6	Collision
	7	Link

a. The MII Shadow register is accessed by setting MII register 1Fh bit 7 to 1.

Table 12: Low-Cost Serial Mode Bank 6 LED Selection

<i>MII Shadow Register ^a1Ah, PHY 2, Bits [8:6]</i>	<i>Value</i>	<i>LED Selection</i>
SERIAL BANK 6 SELECT BITS[2:0]	0	Link
	1	Speed
	2	Activity
	3	Full-duplex
	4	Transmit
	5	Receive
	6	Interrupt
	7	Collision

a. The MII Shadow register is accessed by setting MII register 1Fh bit 7 to 1.



PARALLEL LED MODE

The BCM5228U offers a parallel LED mode that is active all the time. There are 3 LED pins, LED1, LED2, and LED3 for each port each of which can be individually configured to output one of many LED signals. Configuration can be accomplished either by hardware or programming MII register bits. LED1 pins are shared with TXER. These pins can be configured to output LED1 if TXER_EN pin is pulled low during power-on reset.

For unmanaged system design using the BCM5228U, the parallel LED pins for each port can be programmed through hardware during power-on reset by pull-down or pull-up combinations of TXER/LED1 [1:8] pins. Pull-up and pull-down of these pins should be done using a series 4.7-k Ω resistor to OVDD or OGND respectively and LED drive and polarity should be such that the active low output on LED1 lights up the LED. LED2 and LED3 can be configured to output one of Link, Speed, Activity, Full-duplex, Transmit, Receive, Interrupt or Collision while LED3 can be configured to be one of Activity, Full-duplex, Link or Speed. Software configuration of LED1, LED2 and LED3 is accomplished through MII shadow register 1Ah, Phy 1, bits [7:0]. For details, see [Table 13](#), [Table 14](#), and [Table 15](#). Because LED2{1:8} pins are open drain, they can be wire 0Red together and configured (by hardware during power-on reset or through software by setting bits in the MII shadow register) to provide global hardware interrupt when required.

Table 13: Parallel LED Mode LED1 Selection

TXER[3:1]	MII Shadow Register ^a 1Ah, PHY 1, Bits [2:0]	Value	LED1 Selection
POWER-ON LED1 SELECT BITS[2:0]	LED1 SELECT[2:0]	0	Link
		1	Speed
		2	Activity
		3	Full-duplex
		4	Transmit
		5	Receive
		6	Interrupt
		7	Collision

a. The MII Shadow register is accessed by setting MII register 1Fh bit 7 to 1.

Table 14: Parallel LED Mode LED2 Selection

TXER [6:4]	MII Shadow Register ^a 1Ah, PHY 1, Bits [5:3]	Value	LED2 Selection
POWER-ON RESET LED2 SELECT[2:0]	LED2 SELECT[2:0]	0	Speed
		1	Activity
		2	Full-duplex
		3	Transmit
		4	Receive
		5	Interrupt
		6	Collision
		7	Link

a. The MII Shadow register is accessed by setting MII register 1Fh bit 7 to 1.

Table 15: Parallel LED Mode LED3 Selection

<i>TXER [8:7]</i>	<i>MII Shadow Register^a 1Ah, PHY 1, Bits [7:6]</i>	<i>Value</i>	<i>LED3 Selection</i>
POWER-ON RESET LED3 SELECT[1:0]	LED3 SELECT[1:0]	0	Activity
		1	Full-duplex
		2	Link
		3	Speed

a. The MII Shadow register is accessed by setting MII register 1Fh bit 7 to 1.



Section 6: Register Summary

MII MANAGEMENT INTERFACE: REGISTER PROGRAMMING

The BCM5228 fully complies with the IEEE 802.3u Media Independent Interface (MII) specification. The MII management interface registers of each port are serially written-to and read from using a common set of MDIO and MDC pins. A single clock waveform must be provided to the BCM5228 at a rate of 0–25 MHz through the MDC pin. The serial data is communicated on the MDIO pin. Every MDIO bit must have the same period as the MDC clock. The MDIO bits are latched on the rising edge of the MDC clock. Every MII read or write instruction frame contains the following fields:

Table 16: MII Management Frame Format

Operation	PRE	ST	OP	PHYAD	REGAD	TA	Data	Idle	Direction
Read	1 ... 1	01	10	AAAAA	RRRRR	ZZ Z0	Z ... Z D ... D	Z Z	Driven to BCM5228 Driven by BCM5228
Write	1 ... 1	01	01	AAAAA	RRRRR	10	D ... D	Z	Driven to BCM5228

Preamble (PRE). Thirty-two consecutive 1 bits must be sent through the MDIO pin to the BCM5228 to signal the beginning of an RMII instruction. Fewer than thirty-two 1 bits causes the remainder of the instruction to be ignored.

Start of Frame (ST). A 01 pattern indicates that the start of the instruction follows.

Operation Code (OP). A Read instruction is indicated by 10, while a Write instruction is indicated by 01.

PHY Address (PHYAD). A 5-bit PHY address follows next, with the MSB transmitted first. The PHY address allows a single MDIO bus to access multiple PHY chips. The BCM5228 supports a complete address space with PHYAD[4:0] input-pins used as the base address for selecting one of the eight transceivers.

Register Address (REGAD). A 5-bit register address follows, with the MSB transmitted first. The register map of the BCM5228, containing register addresses and bit definitions, are provided on the following pages.

Turnaround (TA). The next two bit times are used to avoid contention on the MDIO pin when a Read operation is performed. For a Write operation, 10 must be sent to the BCM5228 chip during these two bit times. For a Read operation, the MDIO pin must be placed into High-Impedance during these two bit times. The chip drives the MDIO pin to 0 during the second bit time.

Data. The last 16 bits of the frame are the actual data bits. For a Write operation, these bits are sent to the BCM5228, whereas, for a read operation, these bits are driven by the BCM5228. In either case, the MSB is transmitted first. When writing to the BCM5228, the data field bits must be stable 10 ns before the rising edge of MDC, and must be held valid for 10 ns after the rising edge of MDC. When reading from the BCM5228, the data field bits are valid after the rising-edge of MDC until the next rising edge of MDC.

Idle. A high impedance state of the MDIO line. All tri-state drivers are disabled and the PHY's pull-up resistor pulls the MDIO line to logic 1.

At least one or more idle states are required between frames. The following shows two examples of MII write and read instructions.

- To put a transceiver with PHY address 00001 into Loopback mode, the following MII write instruction must be issued:
1111 1111 1111 1111 1111 1111 1111 1111 0101 00001 00000 10 0100 0000 0000 0000 1...
- To determine if a PHY is in the link pass state, the following MII read instruction must be issued:
1111 1111 1111 1111 1111 1111 1111 1111 0110 00001 00001 ZZ ZZZZ ZZZZ ZZZZ ZZZZ 1...

For the MII read operation, the BCM5228 drives the MDIO line during the TA and Data fields (the last 17 bit times). A final 65th clock pulse must be sent to close the transaction and cause a write operation to take place.



MII REGISTER MAP SUMMARY

Table 17 contains the MII register map summary for each port of the BCM5228. The register addresses are specified in hex form, and the name of register bits have been abbreviated. When writing to any register, preserve existing values of the reserved bits by completing a "Read/Modify Write." Ignore reserved bits when reading registers. Never write to an undefined register. The reset values of the registers are shown in the INIT column. Some of these values could be different depending on how the device is configured and also depending on the device revision value.

Table 17: MII Register Map Summary

Addr	Name	15	14	13	12	11	10	9	8	7	6	5	4	3	2	1	0	Init	
00h	Control	Soft Reset	Loopback	Force100	Auto-neg Enable	Power Down	Isolate	Restart Auto-neg	Full-duplex	Collision Test	Reserved							3000h	
01h	Status	T4 Capable	TX FDX Capable	TX Capable	BASE-T FDX Capable	10BASE-T Capable	Pause	Adv T4	Adv TX FDX	Adv TX	MF_pream suppress	Auto-neg comp	Remote Fault	Auto-neg Capable	Link Status	Jabber Detect	Ext'd Reg Capable	7809h	
02h	PhyID High	0	0	0	0	0	0	0	0	0	1	0	0	0	0	0	0	0040h	
03h	PhyID Low	0	1	1	0	0	0	0	1	1	Model #	0	1	0	0	Revision #	0	61D0h	
04h	Aut-neg Advertise	Next Page	Reserved	Remote Fault	Reserved Tech	Reserved Tech	Pause	Adv T4	Adv TX FDX	Adv TX	Adv BASE-T FDX	Adv BASE-T	0	0	0	Advertised Selector Field[4:0]	0	01E1h	
05h	Link Partner Ability	LP Next Page	LP Acknowledge	LP Rem Fault	Reserved Tech	Reserved Tech	LP Pause	LP T4	LP TX FDX	LP TX	LP BASE-T FDX	LP BASE-T	LP BASE-T	Link Partner Selector Field [4:0]				0000h	
06h	Auto-neg Expansion	Reserved																	
07h	Next Page	Next Page	Reserved	Message Page	Acknowledge2	Acknowledge2	Toggle	Message/Unformatted Code Field											0004h
08h	LP Next Page	Next Page	Reserved	Message Page	Acknowledge2	Acknowledge2	Toggle	Message/Unformatted Code Field											2001h
10h	100BASE-X Aux Control	Reserved	Reserved	Trans Disable	Reserved	Reserved	Bypass 4B5B Enc/Dec	Bypass Scram/Descram	Bypass NRZ1 Enc/Dec	Bypass Rcv Sym Align	Baseline Wander Disable	FEF Enable	Reserved	Reserved	Extended FIFO Enable	Reserved	Reserved	0000h	
11h	100BASE-X Aux Status	Reserved	Reserved	Reserved	R/S/MI Over Under Run	R/S/MI Over Under Run	FX Mode	Locked	Current 100 Link Status	Current Remote Fault	Reserved	False Carrier Detected	Bad ESD Detected	RCV Error Detected	XMT Error Detected	Lock Error Detected	MLT3 Error Detected	0000h	
12h	100BASE-X RCV Error Counter	Receive Error Counter[15:0]																	0000h
13h	100BASE-X False Carrier Counter	RMI/SMII Overrun/Underrun Counter[7:0]																	0000h
14h	100BASE-X Disconnect Counter	RMI/SMII Slowrxd																	0200h
15h	Reserved	Reserved																	0300h
16h	Reserved	Reserved																	0000h
17h	PTTest	Reserved																	0000h
18h	Auxiliary Control/Status	Jabber Disable	Force Link	Reserved	Reserved	Reserved	TXDAC Power Mode	HSQ	LSQ	Edge Rate[1:0]	Auto-neg Enable Indication	Force 100 Indication	SP100 Indication	SP100 Indication	Link Status	Internal Auto-neg Enabled	FDX Indication	0033h	
19h	Auxiliary Status Summary	Auto-neg Complete	Auto-neg Complete Ack	Auto-neg Ack Detect	Auto-neg Ability Detect	Auto-neg Pause	Auto-neg HCD	Auto-neg Parquet Fault	LP Remote Fault	LP Page Rcvd	LP Page Fault	LP Page Rcvd	LP Auto-neg Able	SP100 Indication	Link Status	Internal Auto-neg Enabled	Full-duplex Indication	0000h	

Table 17: MII Register Map Summary (Cont.)

Addr	Name	15	14	13	12	11	10	9	8	7	6	5	4	3	2	1	0	Init
1Ah	Interrupt	FDX LED Enable	INTR Enable	Reserved	Reserved	FDX Mask	SPD Mask	Link Mask	INTR Mask	Reserved	Reserved	Reserved	Global Interrupt Status	FDX Change	SPD Change	Link Change	INTR Status	0F0xh
1Bh	Auxiliary Mode2	Reserved	Reserved	Reserved	Reserved	10BASE-T Dribble Correct	Jumbo Packet Enable	Jumbo Packet FIFO Enable	Reserved	Block 10BASE-T Echo Mode	Traffic Meter LED Mode	Activity LED Force On	Serial LED Enable (PHY 2 of 8)	SQE Disable	Activity/Link LED Enable	Qual Parallel Detect Mode	Reserved	008Ah
1Ch	10BASE-T Auxiliary Error and General Status	Reserved	Reserved	MDIX Status	MDIX Manual Swap	HP Auto-MDIX Disable	Manchstr Code Enable (BASE-T)	EOF Enable (BASE-T)	Reserved	0	0	1	Reserved	Auto-neg Enable Indicator	Force 100 Indicator	SP100 Indicator	FDX Indicator	002xh
1Dh	Auxiliary Mode	Reserved	Reserved	Reserved	Reserved	Reserved	Reserved	Reserved	Reserved	Reserved	Reserved	Reserved	Activity LED Force Inactive	Link LED Force Inactive	Reserved	Block TXEN Mode	Reserved	x000h
1Eh	Auxiliary Multi-PHY	HCD TX FDX	HC T4	HCD TX	HCD 10BASE-T FDX	HCD 10BASE-T	Reserved	Reserved	Restart Auto-neg	Auto-neg Complete	Reserved	ACK Detect	Ability Detect	Super Isolate	Reserved	Reserved	RXER Code Mode	0000h
1Fh	Broadcom Test	Reserved	Reserved	Reserved	Reserved	Reserved	Reserved	Shadow Register Enable	Reserved	Reserved	Reserved	Reserved	Reserved	Reserved	Reserved	Reserved	Reserved	000Bh

Table 18: MII Shadow Register Map Summary (MII Register 1Fh, bit7 = 1)

Addr	Name	15	14	13	12	11	10	9	8	7	6	5	4	3	2	1	0	Init
18h	Reserved	Reserved	Reserved	Reserved	Reserved	Reserved	Reserved	Reserved	Reserved	Reserved	Reserved	Reserved	Reserved	Reserved	Reserved	Reserved	Reserved	003Ah
1Ah	Auxiliary Mode 4 (PHY 1)	Reserved	Reserved	Reserved	Reserved	Reserved	Reserved	Parallel LED3 Select[1:0]	MII LED Select Enable	Parallel LED2 Select[2:0]	Parallel LED1 Select[2:0]	Parallel LED1 Select[2:0]	Parallel LED1 Select[2:0]	Parallel LED1 Select[2:0]	Parallel LED1 Select[2:0]	Parallel LED1 Select[2:0]	Parallel LED1 Select[2:0]	3000h
1Ah	Auxiliary Mode 4 (PHY 2)	Reserved	Reserved	Reserved	Reserved	Reserved	Reserved	Serial Bank 6 Select[2:0]	Serial Bank 6 Select[2:0]	Serial Bank 5 Select[2:0]	Serial Bank 4 Select[2:0]	Serial Bank 4 Select[2:0]	Serial Bank 4 Select[2:0]	Serial Bank 4 Select[2:0]	Serial Bank 4 Select[2:0]	Serial Bank 4 Select[2:0]	Serial Bank 4 Select[2:0]	3000h
1Ah	Auxiliary Mode 4 (PHY 3)	Reserved	Reserved	Reserved	Reserved	Reserved	Reserved	Serial Bank 3 Select[2:0]	Serial Bank 3 Select[2:0]	Serial Bank 2 Select[2:0]	Serial Bank 2 Select[2:0]	Serial Bank 2 Select[2:0]	Serial Bank 2 Select[2:0]	Serial Bank 2 Select[2:0]	Serial Bank 2 Select[2:0]	Serial Bank 2 Select[2:0]	Serial Bank 2 Select[2:0]	3000h
1Bh	Auxiliary Status 2	MLT3 Detect	Cable Length 100x[2:0]	Cable Length 100x[2:0]	Cable Length 100x[2:0]	Cable Length 100x[2:0]	ADC Peak Amplitude[5:0]	ADC Peak Amplitude[5:0]	APD Enable	APD Sleep Timer	APD Wake-Up Timer[3:0]	APD Wake-Up Timer[3:0]	APD Wake-Up Timer[3:0]	APD Wake-Up Timer[3:0]	APD Wake-Up Timer[3:0]	APD Wake-Up Timer[3:0]	APD Wake-Up Timer[3:0]	0001h
1Ch	Auxiliary Status 3	Noise[7:0] (Root Mean Square error)	Noise[7:0] (Root Mean Square error)	Noise[7:0] (Root Mean Square error)	Noise[7:0] (Root Mean Square error)	Noise[7:0] (Root Mean Square error)	Noise[7:0] (Root Mean Square error)	FLP Detect	Link Break Timer Expire	Link Fail Timer Expire	FIFO Consumption[3:0]	FIFO Consumption[3:0]	FIFO Consumption[3:0]	FIFO Consumption[3:0]	FIFO Consumption[3:0]	FIFO Consumption[3:0]	FIFO Consumption[3:0]	0000h
1Dh	Auxiliary Mode 3	Reserved	Reserved	Reserved	Reserved	Reserved	Reserved	Reserved	Reserved	Reserved	Reserved	Reserved	Reserved	Reserved	Reserved	Reserved	Reserved	0004h
1Eh	Auxiliary Status4	Packet Length Counter[15:0]	Packet Length Counter[15:0]	Packet Length Counter[15:0]	Packet Length Counter[15:0]	Packet Length Counter[15:0]	Packet Length Counter[15:0]	Packet Length Counter[15:0]	Packet Length Counter[15:0]	Packet Length Counter[15:0]	Packet Length Counter[15:0]	Packet Length Counter[15:0]	Packet Length Counter[15:0]	Packet Length Counter[15:0]	Packet Length Counter[15:0]	Packet Length Counter[15:0]	Packet Length Counter[15:0]	0000h

MII CONTROL REGISTER

Table 19: MII Control Register (Address 00d, 00h)

Bit	Name	R/W	Description	Default
15	Soft Reset	R/W (SC)	1 = PHY reset 0 = Normal operation	0
14	Loopback	R/W	1 = loopback mode 0 = Normal operation	0
13	Forced Speed Selection	R/W	1 = 100 Mbps 0 = 10 Mbps	1
12	Auto-Negotiation Enable	R/W	1 = Auto-negotiation enable 0 = Auto-negotiation disable	1
11	Power Down	RO	0 = Normal operation	0
10	Isolate	R/W	1 = Electrically isolate PHY from RMII 0 = Normal operation	0
9	Restart Auto-Negotiation	R/W (SC)	1 = Restart auto-negotiation process 0 = Normal operation	0
8	Duplex Mode	R/W	1 = Full-duplex 0 = Half-duplex	0
7	Reserved ^a	–	–	0
6:0	Reserved ^a	–	–	0

Note: R/W = Read/Write, RO = Read Only, SC = Self Clear, LL = Latched Low, LH = Latched High, LL and LH Clear after read operation.

- a. Preserve existing values of reserved bits by completing a “Read/Modify Write.”

Soft Reset. To reset the BCM5228 by software control, a 1 must be written to bit 15 of the Control register using an MII write operation. The bit clears itself after the reset process is complete, and need not be cleared using a second MII write. Writes to other Control register bits have no effect until the reset process is completed, which requires approximately 1 microsecond. Writing a 0 to this bit has no effect. Since this bit is self-clearing, after a few cycles from a write operation, it returns a 0 when read.

Loopback. The BCM5228 can be placed into loopback mode by writing a 1 to bit 14 of the Control register. The loopback mode can be cleared by writing a 0 to bit 14 of the Control register, or by resetting the chip. When this bit is read, it returns a 1 when the chip is in software-controlled loopback mode, otherwise it returns a 0.

Forced Speed Selection. If auto-negotiation is enabled, this bit has no effect on the speed selection. However, if auto-negotiation is disabled by software control, the operating speed of the BCM5228 can be forced by writing the appropriate value to bit 13 of the Control register. Writing a 1 to this bit forces 100BASE-X operation, while writing a 0 forces 10BASE-T operation. When this bit is read, it returns the value of the software-controlled forced speed selection only. In order to read the overall state of forced speed selection, including both hardware and software control, use bit 20 of the Auxiliary Error and General Status register, 1Ch.

Auto-Negotiation Enable. Auto-negotiation can be disabled by one of two methods: hardware or software control. If the ANEN input pin is driven to a logic 0, auto-negotiation is disabled by hardware control. If bit 12 of the Control register is written with a value of 0, auto-negotiation is disabled by software control. When auto-negotiation is disabled in this manner, writing a 1 to the same bit of the Control register or resetting the chip re-enables auto-negotiation. Writing to this bit has no effect when auto-negotiation has been disabled by hardware control. When read, this bit returns the value most recently written to this location, or 1 if it has not been written since the last chip reset.



Power Down. The BCM5228 does not implement power-down mode. However, the device does support auto power-down mode (see “[Auto Power-Down Mode](#)” on page 24).

Isolate. Each individual PHY can be isolated from its Media Independent Interface by writing a 1 to bit 10 of the Control register. All RMII outputs is tri-stated and all RMII/SMII/S3MII inputs are ignored. Because the MII/SMII/S3MII management interface is still active, the isolate mode can be cleared by writing a 0 to bit 10 of the Control register, or by resetting the chip. When this bit is read, it returns a 1 when the chip is in isolate mode, otherwise, it returns a 0. See also “[Isolate Mode](#)” on page 24.

Restart Auto-Negotiation. Bit 9 of the Control register is a self-clearing bit that allows the auto-negotiation process to be restarted, regardless of the current status of the auto-negotiation state machine. In order for this bit to have an effect, auto-negotiation must be enabled. Writing a 1 to this bit restarts the auto-negotiation, while writing a 0 to this bit has no effect. Since the bit is self-clearing after only a few cycles, it always returns a 0 when read. The operation of this bit is identical to bit 9 of the Auxiliary Multiple PHY register.

Duplex Mode. By default, the BCM5228 powers up in half-duplex mode. The chip can be forced into full-duplex mode by writing a 1 to bit 8 of the Control register while auto-negotiation is disabled. Half-duplex mode can be resumed by writing a 0 to bit 8 of the Control register, or by resetting the chip.

MII STATUS REGISTER

Table 20: MII Status Register (Address 01d, 01h)

Bit	Name	R/W	Description	Default
15	100BASE-T4 Capability	RO	0 = Not 100BASE-T4 capable	0
14	100BASE-TX FDX Capability	RO	1 = 100BASE-TX full-duplex capable	1
13	100BASE-TX Capability	RO	1 = 100BASE-TX half-duplex capable	1
12	10BASE-T FDX Capability	RO	1 = 10BASE-T full-duplex capable	1
11	10BASE-T Capability	RO	1 = 10BASE-T half-duplex capable	1
10:7	Reserved ^a	–	–	0000
6	MF Preamble Suppression	R/W	1 = Preamble may be suppressed 0 = Preamble always required	0
5	Auto-Negotiation Complete	RO	1 = Auto-negotiation process completed 0 = Auto-negotiation process not completed	0
4	Remote Fault	RO LH	1 = Far-End Fault condition detected 0 = No Far-End Fault condition detected	0
3	Auto-Negotiation Capability	RO	1 = Auto-negotiation capable 0 = Not auto-negotiation capable	1
2	Link Status	RO LL	1 = Link is up (Link Pass state) 0 = Link is down (Link Fail state)	0
1	Jabber Detect	RO LH	1 = Jabber condition detected 0 = No Jabber condition detected	0
0	Extended Capability	RO	1 = Extended register capable	1

Note: R/W = Read/Write, RO = Read Only, SC = Self Clear, LL = Latched Low, LH = Latched High, LL and LH Clear after read operation.

a. Preserve existing values of reserved bits by completing a "Read/Modify Write."

100BASE-T4 Capability. The BCM5228 is not capable of 100BASE-T4 operation, and returns a 0 when bit 15 of the status register is read.

100BASE-X Full-Duplex Capability. The BCM5228 is capable of 100BASE-X full-duplex operation, and returns a 1 when bit 14 of the Status register is read.

100BASE-X Half-Duplex Capability. The BCM5228 is capable of 100BASE-X half-duplex operation, and returns a 1 when bit 13 of the Status register is read.

10BASE-T Full-Duplex Capability. The BCM5228 is capable of 10BASE-T full-duplex operation, and returns a 1 when bit 12 of the Status register is read.

10BASE-T Half-Duplex Capability. The BCM5228 is capable of 10BASE-T half-duplex operation, and returns a 1 when bit 11 of the Status register is read.

MF Preamble Suppression. This bit is the only writable bit in the Status register. Setting this bit to a 1 allows subsequent MII management frames to be accepted with or without the standard preamble pattern. When preamble suppression is enabled, only two preamble bits are required between successive management commands, instead of the normal 32.

Auto-Negotiation Complete. Bit 5 of the Status register returns a 1 if the auto-negotiation process has been completed and the contents of registers 4, 5 and 6 are valid.

Remote Fault. The PHY returns a 1 in bit 4 of the Status register when its link partner has signalled a far-end fault condition. When a far-end fault occurs, the bit is latched at 1 and remains so until the register is read and the remote fault condition has been cleared. This only applies to the FX mode of operation.

Auto-Negotiation Capability. The BCM5228 is capable of performing IEEE auto-negotiation, and returns a 1 when bit 4 of the Status register is read, regardless of whether or not the auto-negotiation function has been disabled.

Link Status. The BCM5228 returns a 1 on bit 2 of the Status register when the link state machine is in Link Pass, indicating that a valid link has been established. Otherwise, it returns 0. When a link failure occurs after the Link Pass state has been entered, the Link Status bit is latched at 0 and remains so until the bit is read. After the bit is read, it becomes 1 if the Link Pass state has been entered again.

Jabber Detect. 10BASE-T operation only. The BCM5228 returns a 1 on bit 1 of the Status register if a jabber condition has been detected. After the bit is read, or if the chip is reset, it reverts to 0.

Extended Capability. The BCM5228 supports extended capability registers, and returns a 1 when bit 0 of the Status register is read. Several extended registers have been implemented in the BCM5228, and their bit functions are defined later in this section.

PHY IDENTIFIER REGISTERS

Table 21: PHY Identifier Registers (Addresses 02d and 03d, 02h and 03h)

Bit	Name	R/W	Description	Value
15:0	MII Address 00010	RO	PHYID high	0040h
15:0	MII Address 00011	RO	PHYID low	XXXXh

Broadcom Corporation has been issued an Organizationally Unique Identifier (OUI) by the IEEE. It is a 24-bit number, 00-10-18, expressed as hex values (the two most significant bits (OUI[23:22]) of the OUI are not represented). That number, along with the Broadcom Model Number for the BCM5228 part, 1Ch, and Broadcom Revision number, 00h, is placed into two MII registers. The translation from OUI, Model Number and Revision Number to PHY Identifier register occurs as follows:

$$\text{PHYID High}[15:0] = \text{OUI}[21:6]$$

$$\text{PHYID Low}[15:0] = \text{OUI}[5:0] + \text{Model}[5:0] + \text{Rev}[3:0]$$

Figure 21 on page 40 shows the result of concatenating these values to form the MII Identifier registers PHYID HIGH and PHYID LOW.

AUTO-NEGOTIATION ADVERTISEMENT REGISTER

Table 22: Auto-Negotiation Advertisement Register (Address 04d, 04h)

Bit	Name	R/W	Description	Default
15	Next Page	R/W	1 = Next page ability is enabled 0 = Next page ability is disabled	0
14	Reserved ^a	–	–	0
13	Remote Fault	R/W	1 = Transmit remote fault	0
12:11	Reserved Technologies	RO	Ignore when read	00
10	Pause	R/W	1 = Pause operation for full-duplex	0
9	Advertise 100BASE-T4	R/W	1 = Advertise T4 capability 0 = Do not advertise T4 capability	0
8	Advertise 100BASE-X FDX	R/W	1 = Advertise 100BASE-X full-duplex 0 = Do not advertise 100BASE-X full-duplex	1
7	Advertise 100BASE-X	R/W	1 = Advertise 100BASE-X	1
6	Advertise 10BASE-T FDX	R/W	1 = Advertise 10BASE-T full-duplex 0 = Do not advertise 10BASE-T full-duplex	1
5	Advertise 10BASE-T	R/W	1 = Advertise 10BASE-T	1
4:0	Advertise Selector Field	R/W	Indicates 802.3	00001

Note: R/W = Read/Write, RO = Read Only, SC = Self Clear, LL = Latched Low, LH = Latched High, LL and LH Clear after read operation.

a. Preserve existing values of reserved bits by completing a “Read/Modify Write.”

Next Page. The BCM5228 supports the Next Page function.

Remote Fault. Writing a 1 to bit 13 of the Advertisement register causes a remote fault indicator to be sent to the link partner during auto-negotiation. Writing a 0 to this bit or resetting the chip clears the Remote Fault transmission bit. This bit returns the value last written to it, or else 0, if no write has been completed since the last chip reset.

Reserved Technologies. Ignore output when read.

Pause. Pause operation for full-duplex links. The use of this bit is independent of the negotiated data rate, medium, or link technology. The setting of this bit indicates the availability of additional DTE capability when full-duplex operation is in use. This bit is used by one MAC to communicate pause capability to its link partner and has no effect on PHY operation.

Advertise. Bits 9:5 of the Advertisement register allow the user to customize the ability information transmitted to the link partner. The default value for each bit reflects the abilities of the BCM5228. By writing a 1 to any of the bits, the corresponding ability is transmitted to the link partner. Writing a 0 to any bit causes the corresponding ability to be suppressed from transmission. Resetting the chip restores the default bit values. Reading the register returns the values last written to the corresponding bits, or else the default values if no write has been completed since the last chip reset.

Advertise Selector Field. Bits 4:0 of the Advertisement register contain the value 00001, indicating that the chip belongs to the 802.3 class of PHY transceivers.

AUTO-NEGOTIATION LINK PARTNER (LP) ABILITY REGISTER

Table 23: Auto-Negotiation Link Partner Ability Register (Address 05d, 05h)

Bit	Name	R/W	Description	Default
15	LP Next Page	RO	Link partner next page bit	0
14	LP Acknowledge	RO	Link partner acknowledge bit	0
13	LP Remote Fault	RO	Link partner remote fault indicator	0
12:11	Reserved Technologies	RO	Ignore when read	000
10	LP Advertise Pause	RO	Link partner has pause capability	0
9	LP Advertise 100BASE-T4	RO	Link partner has 100BASE-T4 capability	0
8	LP Advertise 100BASE-X FDX	RO	Link partner has 100BASE-X FDX capability	0
7	LP Advertise 100BASE-X	RO	Link partner has 100BASE-X capability	0
6	LP Advertise 10BASE-T FDX	RO	Link partner has 10BASE-T FDX capability	0
5	LP Advertise 10BASE-T	RO	Link partner has 10BASE-T capability	0
4:0	Link Partner Selector Field	RO	Link partner selector field	00000

Note: R/W = Read/Write, RO = Read Only, SC = Self Clear, LL = Latched Low, LH = Latched High, LL and LH Clear after read operation.

The values contained in the Auto-Negotiation Link Partner Ability register are only guaranteed to be valid after auto-negotiation has successfully completed, as indicated by bit 5 of the MII Status register.

LP Next Page. Bit 15 of the Link Partner Ability register returns a value of 1 when the link partner implements the Next Page function and has Next Page information that it wants to transmit. The BCM5228 does not implement the Next Page function, and thus ignores the Next Page bit, except to copy it to this register.

LP Acknowledge. Bit 14 of the Link Partner Ability register is used by auto-negotiation to indicate that a device has successfully received its link partner's link code word.

LP Remote Fault. Bit 13 of the Link Partner Ability register returns a value of 1 when the link partner signals that a remote fault has occurred. The BCM5228 simply copies the value to this register and does not act upon it.

Reserved Technologies. Ignore when read.

LP Advertise Pause. Indicates that the Link Partner Pause bit is set.

LP Advertise. Bits 9:5 of the Link Partner Ability register reflect the abilities of the link partner. A 1 on any of these bits indicates that the Link Partner is capable of performing the corresponding mode of operation. Bits 9:5 are cleared any time auto-negotiation is restarted or the BCM5228 is reset.

Link Partner Selector Field. Bits 4:0 of the Link Partner Ability register reflect the value of the link partner's selector field. These bits are cleared any time auto-negotiation is restarted or the chip is reset.

AUTO-NEGOTIATION EXPANSION REGISTER

Table 24: Auto-Negotiation Expansion Register (Address 06d, 06h)

Bit	Name	R/W	Description	Default
15:5	Reserved ^a	–	–	000h
4	Parallel Detection Fault	RO LH	1 = Parallel detection fault. 0 = No parallel detection fault	0
3	Link Partner Next Page Able	RO	1 = Link partner has next page capability 0 = Link partner does not have next page	0
2	Next Page Able	RO	1 = Next page able	1
1	Page Received	RO	1 = New page has been received 0 = New page has not been received	0
0	Link Partner Auto-Negotiation Able	RO LH	1 = Link partner has auto-negotiation capability 0 = Link partner does not have auto-negotiation	0

Note: R/W = Read/Write, RO = Read Only, SC = Self Clear, LL = Latched Low, LH = Latched High, LL and LH Clear after read operation.

- a. Preserve existing values of reserved bits by completing a "Read/Modify Write."

Parallel Detection Fault. Bit 4 of the Auto-Negotiation Expansion register is a read-only bit that gets latched high when a parallel detection fault occurs in the auto-negotiation state machine. For further details, consult the IEEE standard. The bit is reset to 0 after the register is read or when the chip is reset.

Link Partner Next Page Able. Bit 3 of the Auto-Negotiation Expansion register returns a 1 when the link partner has Next Page capabilities. It has the same value as bit 15 of the Link Partner Ability register.

Next Page Able. The BCM5228 Returns 1 when bit 2 of the auto-negotiation Expansion register is read indicating that it has Next Page capabilities.

Page Received. Bit 1 of the Auto-Negotiation Expansion register is latched high when a new link code word is received from the link partner, checked, and acknowledged. It remains high until the register is read, or until the chip is reset.

Link Partner Auto-Negotiation Able. Bit 0 of the Auto-Negotiation Expansion register returns a 1 when the link partner is known to have auto-negotiation capability. Before any auto-negotiation information is exchanged, or if the link partner does not comply with IEEE auto-negotiation, the bit returns a value of 0.

AUTO-NEGOTIATION NEXT PAGE REGISTER

Table 25: Next Page Transmit Register (Address 07d, 07h)

Bit	Name	R/W	Description	Default
15	Next Page	R/W	1 = Additional next page(s) follows 0 = Last page	0
14	Reserved ^a	–	–	0
13	Message Page	R/W	1 = Message page 0 = Unformatted page	1
12	Acknowledge 2	R/W	1 = Complies with message 0 = Cannot comply with message	0
11	Toggle	RO	1 = Previous value of the transmitted link code word equalled logic zero 0 = Previous value of the transmitted link code word equalled logic one	0
10:0	Message/Unformatted Code Field	R/W		1

Note: R/W = Read/Write, RO = Read Only, SC = Self Clear, LL = Latched Low, LH = Latched High, LL and LH Clear after read operation.

a. Preserve existing values of reserved bits by completing a "Read/Modify Write."

Next Page. Indicates whether this is the last Next Page to be transmitted.

Message Page. Differentiates a Message Page from an unformatted page.

Acknowledge 2. Indicates that a device has the ability to comply with the message.

Toggle. Used by the arbitration function to ensure synchronization with the link partner during Next Page exchange.

Message Code Field. An 11-bit wide field, encoding 2048 possible messages.

Unformatted Code Field. An 11-bit wide field, which can contain an arbitrary value.

AUTO-NEGOTIATION LINK PARTNER (LP) NEXT PAGE TRANSMIT REGISTER

Table 26: Next Page Transmit Register (Address 08d, 08h)

Bit	Name	R/W	Description	Default
15	Next Page	RO	1 = Additional next page(s) follows 0 = Last page	0
14	Reserved ^a	–	–	0
13	Message Page	RO	1 = Message page 0 = Unformatted page	0
12	Acknowledge 2	RO	1 = Complies with message 0 = Cannot comply with message	0
11	Toggle	RO	1 = Previous value of the transmitted link code word equalled logic zero 0 = Previous value of the transmitted link code word equalled logic one	0
10:0	Message/Unformatted Code Field	RO		0

Note: R/W = Read/Write, RO = Read Only, SC = Self Clear, LL = Latched Low, LH = Latched High, LL and LH Clear after read operation.

a. Preserve existing values of reserved bits by completing a “Read/Modify Write.”

Next Page. Indicates whether this is the last Next Page.

Message Page. Differentiates a Message Page from an unformatted page.

Acknowledge 2. Indicates that link partner has the ability to comply with the message.

Toggle. Used by the arbitration function to ensure synchronization with the link partner during Next Page exchange.

Message Code Field. An 11-bit wide field, encoding 2048 possible messages.

Unformatted Code Field. An 11-bit wide field, which can contain an arbitrary value.

100BASE-X AUXILIARY CONTROL REGISTER

Table 27: 100-BASE-X Auxiliary Control Register (Address 16d, 10h)

Bit	Name	R/W	Description	Default
15:14	Reserved ^a	–	–	0
13	Transmit Disable	R/W	1 = Transmitter disabled in PHY 0 = Normal operation	0
12:11	Reserved ^a	–	–	0
10	Bypass 4B5B Encoder/Decoder	R/W	1 = Transmit and receive 5B codes over RMII pins 0 = Normal RMII	0
9	Bypass Scrambler/Descrambler	R/W	1 = Scrambler and descrambler disabled 0 = Scrambler and descrambler enabled	0
8	Bypass NRZI Encoder/Decoder	R/W	1 = NRZI encoder and decoder is disabled 0 = NRZI encoder and decoder is enabled	0
7	Bypass Receive Symbol Alignment	R/W	1 = 5B receive symbols not aligned 0 = Receive symbols aligned to 5B boundaries	0
6	Baseline Wander Correction Disable	R/W	1 = Baseline wander correction disabled 0 = Baseline wander correction enabled	0
5	FEF Enable	R/W	1 = Far-end fault enabled 0 = Far-end fault disabled	0
4:3	Reserved ^a	–	–	0
2	Extended FIFO Enable	R/W	1 = Extended FIFO mode 0 = Normal FIFO mode	0
1:0	Reserved ^a	–	–	00

Note: R/W = Read/Write, RO = Read Only, SC = Self Clear, LL = Latched Low, LH = Latched High, LL and LH Clear after read operation.

a. Preserve existing values of reserved bits by completing a “Read/Modify Write.”

Transmit Disable. The transmitter can be disabled by writing a 1 to bit 13 of MII register 10h. The transmitter output (TD±) is forced into a high impedance state.

Bypass 4B5B Encoder/Decoder. The 4B5B encoder and decoder can be bypassed by writing a 1 to bit 10 of MII register 10h. The transmitter sends 5B codes from the TXER and TXD1, TXD0 pins directly to the scrambler. TXEN must be active, and frame encapsulation (insertion of J/K and T/R codes) is not performed. The receiver places descrambled and aligned 5B codes onto the RXER, RXD1 and RXD0 pins. CRS is asserted when a valid frame is received.

Bypass Scrambler/Descrambler. The stream cipher function can be disabled by writing a 1 to bit 9 of MII register 10h. The Stream Cipher function can be re-enabled by writing a 0 to this bit.

Bypass NRZI Encoder/Decoder. The NRZI encoder and decoder can be bypassed by writing a 1 to bit 8 of MII register 10h, causing 3-level NRZI data to be transmitted and received on the cable. Normal operation (3-level NRZI encoding and decoding) can be re-enabled by writing a 0 to this bit.

Bypass Receive Symbol Alignment. Receive symbol alignment can be bypassed by writing a 1 to bit 7 of MII register 10h. When used in conjunction with the bypass 4B5B encoder/decoder bit, unaligned 5B codes are placed directly on the RXER and RXD1, RXD0 pins.

Baseline Wander Correction Disable. The baseline wander correction circuit can be disabled by writing a 1 to bit 6 of MII register 10h. The BCM5228 corrects for baseline wander on the receive data signal when this bit is cleared.

FEF Enable. Controls the far-end fault mechanism associated with 100BASE-FX operation. A 1 enables the FEF function, and a 0 disables it.

Extended FIFO Enable. Controls the extended receive FIFO mechanism. This bit may have to be set if the Jumbo Packet Enable bit is set. See [Table 4 on page 25](#) for details.

100BASE-X AUXILIARY STATUS REGISTER

Table 28: 100BASE-X Auxiliary Status Register (Address 17d, 11h)

Bit	Name	R/W	Description	Default
15:12	Reserved ^a	–	–	0
11	R/SMII Overrun/Underrun Detected	RO	1 = Error detected 0 = No error	0
10	FX Mode	RO	1 = 100BASE-FX mode 0 = 100BASE-TX or 10BASE-T mode	PIN
9	Locked	RO	1 = Descrambler locked 0 = Descrambler unlocked	0
8	Current 100BASE-X Link Status	RO	1 = Link pass 0 = Link fail	0
7	Remote Fault	RO	1 = Remote fault detected 0 = No remote fault detected	0
6	Reserved ^a	–	–	0
5	False Carrier Detected	RO LH	1 = False carrier detected since last read 0 = No false carrier since last read	0
4	Bad ESD Detected	RO LH	1 = ESD error detected since last read 0 = No ESD error since last read	0
3	Receive Error Detected	RO LH	1 = Receive error detected since last read 0 = No receive error since last read	0
2	Transmit Error Detected	RO LH	1 = Transmit error code received since last read 0 = No transmit error code received since last read	0
1	Lock Error Detected	RO LH	1 = Lock error detected since last read 0 = No lock error since last read	0
0	MLT3 Code Error Detected	RO LH	1 = MLT3 code error detected since last read 0 = No MLT3 code error since last read	0

Note: R/W = Read/Write, RO = Read Only, SC = Self Clear, LL = Latched Low, LH = Latched High, LL and LH Clear after read operation.

a. Preserve existing values of reserved bits by completing a “Read/Modify Write.”

R/SMII Overrun/Underrun Detected. The PHY returns a 1 in bit 11, when the RMII receive FIFO encounters an overrun or underrun condition.

FX Mode. Returns a value derived from the SD± input pins. Returns a 1 when SD± are driven with a valid differential signal level. Returns a 0 when both SD+ and SD– are simultaneously driven low.

Locked. The PHY returns a 1 in bit 9 when the descrambler is locked to the incoming data stream. Otherwise, it returns a 0.

Current 100BASE-X Link Status. The PHY returns a 1 in bit 8 when the 100BASE-X link status is good. Otherwise, it returns a 0.

Remote Fault. The PHY returns a 1 while its link partner is signalling a far-end fault condition. Otherwise, it returns a 0.

False Carrier Detected. The PHY returns a 1 in bit 5 of the Extended Status register if a false carrier has been detected since the last time this register was read. Otherwise, it returns a 0.

Bad ESD Detected. The PHY returns a 1 in bit 4 if an end-of-stream delimiter error has been detected since the last time this register was read. Otherwise, it returns a 0.

Receive Error Detected. The PHY returns a 1 in bit 3 if a packet was received with an invalid code since the last time this register was read. Otherwise, it returns a 0.

Transmit Error Detected. The PHY returns a 1 in bit 2 if a packet was received with a Transmit Error code since the last time this register was read. Otherwise, it returns a 0.

Lock Error Detected. The PHY returns a 1 in bit 1 if the descrambler has lost lock since the last time this register was read. Otherwise, it returns a 0.

MLT3 Code Error Detected. The PHY returns a 1 in bit 0 if an MLT3 coding error has been detected in the receive data stream since the last time this register was read. Otherwise it returns a 0.

100BASE-X RECEIVE ERROR COUNTER

Table 29: 100BASE-X Receive Error Counter (Address 18d, 12h)

<i>Bit</i>	<i>Name</i>	<i>R/W</i>	<i>Description</i>	<i>Default</i>
15:0	Receive Error Counter [15:0]	R/W	Number of non-collision packets with receive errors since last read	0000h

Receive Error Counter [15:0]. This counter increments each time the BCM5228 receives a non-collision packet containing at least one receive error. The counter automatically clears itself when read. When the counter reaches its maximum value, FFh, it stops counting receive errors until cleared

100BASE-X FALSE CARRIER SENSE COUNTER

Table 30: 100BASE-X False Carrier Sense Counter (Address 19d, 13h)

Bit	Name	R/W	Description	Default
15:8	RMII/SMII Overrun/Underrun Counter [7:0]	R/W	Number of RMII overruns/underruns since last read	00h
7:0	False Carrier Sense Counter [7:0]	R/W	Number of false carrier sense events since last read	00h

RMII/SMII Overrun/Underrun Counter [7:0]. The RMII/SMII Overrun/Underrun Counter increments each time the BCM5228 detects an overrun or underrun of the RMII/SMII FIFOs. The counter automatically clears itself when read. When the counter reaches its maximum value, FFh, it stops counting overrun/underrun errors until cleared.

False Carrier Sense Counter [7:0]. This counter increments each time the BCM5228 detects a false carrier on the receive input. This counter automatically clears itself when read. When the counter reaches its maximum value (FFh), it stops counting false carrier sense errors until it is cleared.

100BASE-X DISCONNECT COUNTER

Table 31: 100BASE-X Disconnect Counter

Bit	Name	R/W	Description	Default
15	RMII/SMII Fast RXD	R/O	1 = In extended FIFO mode, detect fast receive data 0 = Normal	0
14	RMII/SMII Slow RXD	R/O	0 = Normal 1 = In extended FIFO mode, detect slow receive data	0
13:8	Reserved ^a	–	–	000010
7:0	Reserved ^a	–	–	00h

Note: R/W = Read/Write, RO = Read Only, SC = Self Clear, LL = Latched Low, LH = Latched High, LL and LH Clear after read operation.

a. Preserve existing values of reserved bits by completing a "Read/Modify Write."

RMII/SMII Fast RXD. Extended FIFO operation only. Bit 15 of the Disconnect Counter register indicates the FIFO state machine has detected fast receive data relative to the REF_CLK input.

RMII/SMII Slow RXD. Extended FIFO operation only. Bit 14 of the Disconnect Counter register indicates the FIFO state machine has detected slow receive data relative to the REF_CLK input.

AUXILIARY CONTROL/STATUS REGISTER

Table 32: Auxiliary Control/Status Register (Address 24d, 18h)

Bit	Name	R/W	Description	Default
15	Jabber Disable	R/W	1 = Jabber function disabled in PHY 0 = Jabber function enabled in PHY	0
14	Link Disable	R/W	1 = Link Integrity test disabled in PHY 0 = Link Integrity test is enabled in PHY	0
13:8	Reserved ^a	–	–	000000
7:6	HSQ:LSQ	R/W	These two bits define the squelch mode of the 10BASE-T carrier sense mechanism: 00 = Normal squelch 01 = Low squelch 10 = High squelch 11 = Not allowed	00
5:4	Edge Rate [1:0]	R/W	00 = 1 ns 01 = 2 ns 10 = 3 ns 11 = 4 ns	11
3	Auto-Negotiation Indicator	RO	1 = Auto-negotiation activated 0 = Speed forced manually	1
2	Force 100/10 Indication	RO	1 = Speed forced to 100BASE-X 0 = Speed forced to 10BASE-T	1
1	Speed Indication	RO	1 = 100BASE-X 0 = 10BASE-T	0
0	Full-Duplex Indication	RO	1 = Full-duplex active 0 = Full-duplex not active	0

Note: R/W = Read/Write, RO = Read Only, SC = Self Clear, LL = Latched Low, LH = Latched High, LL and LH Clear after read operation.

a. Preserve existing values of reserved bits by completing a “Read/Modify Write.”

Jabber Disable. 10BASE-T operation only. Bit 15 of the Auxiliary Control register allows the user to disable the jabber detect function, defined in the IEEE standard. This function shuts off the transmitter when a transmission request has exceeded a maximum time limit. By writing a 1 to bit 15 of the Auxiliary Control register, the jabber detect function is disabled. Writing a 0 to this bit or resetting the chip restores normal operation. Reading this bit returns the value of Jabber Detect Disable.

Link Disable. Writing a 1 to bit 14 of the Auxiliary Control register allows the user to disable the link integrity state machines, and place the BCM5228 into forced link pass status. Writing a 0 to this bit or resetting the chip restores the link integrity functions. Reading this bit returns the value of Link Integrity Disable.

HSQ:LSQ. Extend or decrease the squelch levels for detection of incoming 10BASE-T data packets. The default squelch levels implemented are those defined in the IEEE standard. The high-squelch and low-squelch levels are useful for situations where the IEEE-prescribed levels are inadequate. The squelch levels are used by the CRS/LINK block to filter out noise and recognize only valid packet preambles and link integrity pulses. Extending the squelch levels allows the BCM5228 to operate properly over longer cable lengths. Decreasing the squelch levels can be useful in situations where there is a high level of noise present on the cables. Reading these 2 bits returns the value of the squelch levels.

Edge Rate [1:0]. Control bits used to program the transmit DAC output edge rate in 100BASE-TX mode. These bits are logically ANDed with the ER [1:0] input pins to produce the internal edge-rate controls (Edge_Rate [1] AND ER [1], Edge_Rate [0] AND ER [0]).

Auto-Negotiation Indicator. A read-only bit that indicates whether auto-negotiation has been enabled or disabled on the BCM5228. A combination of a 1 in bit 12 of the Control register and a logic 1 on the ANEN input pin is required to enable auto-negotiation. When auto-negotiation is disabled, bit 3 of the Auxiliary Control register returns a 0. At all other times, it returns a 1.

Force100/10 Indication. A read-only bit that returns a value of 0 when one of following two cases is true:

- The ANEN pin is low AND the F100 pin is low, or
- Bit 12 of the Control register has been written 0 AND bit 13 of the Control register has been written 0.

When bit 8 of the Auxiliary Control register is 0, the speed of the chip is 10BASE-T. In all other cases, either the speed is not forced (auto-negotiation is enabled), or the speed is forced to 100BASE-X.

Speed Indication. Bit 1 of the Auxiliary Control register is a read-only bit that shows the true current operation speed of the BCM5228. A 1 bit indicates 100BASE-X operation, while a 0 indicates 10BASE-T. While the auto-negotiation exchange is performed, the BCM5228 is always operating at 10BASE-T speed

Full-Duplex Indication. Bit 0 of the Auxiliary Control register is a read-only bit that returns a 1 when the BCM5228 is in full-duplex mode. In all other modes, it returns a 0.

AUXILIARY STATUS SUMMARY REGISTER

This register contains copies of redundant status bits found elsewhere within the MII register space.

Table 33: Auxiliary Status Summary Register (Address 25d, 19h)

Bit	Name	R/W	Description	Default
15	Auto-Negotiation Complete	RO	1 = Auto-negotiation process completed	0
14	Auto-Negotiation Complete Acknowledge	RO LH	1 = Auto-negotiation completed acknowledge state	0
13	Auto-Negotiation Acknowledge Detected	RO LH	1 = Auto-negotiation acknowledge detected	0
12	Auto-Negotiation Ability Detect	RO LH	1 = Auto-negotiation for link partner ability	0
11	Auto-Negotiation Pause	RO	BCM5228 and link partner pause operation bit set	0
10:8	Auto-Negotiation HCD	RO	000 = No highest common denominator 001 = 10BASE-T 010 = 10BASE-T full-duplex 011 = 100BASE-TX 100 = 100BASE-T4 101 = 100BASE-TX full-duplex 11x = Undefined	000
7	Auto-Negotiation Parallel Detection Fault	RO LH	1 = Parallel detection fault	0
6	Link Partner Remote Fault	RO	1 = Link partner has signalled a far-end fault condition in FX mode	0
5	Link Partner Page Received	RO LH	1 = New page has been received	0
4	Link Partner Auto-Negotiation Able	RO	1 = Link partner is auto-negotiation capable	0
3	Speed Indicator	RO	1 = 100 Mbps 0 = 10 Mbps	0
2	Link Status	RO LL	1 = Link is up (link pass state)	0
1	Auto-Negotiation Enabled	RO	1 = Auto-negotiation enabled	1
0	Full-Duplex Indication	RO LL	1 = Full-duplex active 0 = Full-duplex not active	0

Note: R/W = Read/Write, RO = Read Only, SC = Self Clear, LL = Latched Low, LH = Latched High, LL and LH Clear after read operation.

Descriptions for each of these individual bits can be found associated with their primary register descriptions.

INTERRUPT REGISTER

Table 34: Interrupt Register (Address 26d, 1Ah)

Bit	Name	R/W	Description	Default
15	FDX LED Enable	R/W	FDX LED enable in serial LED stream	0
14	INTR Enable	R/W	Interrupt enable	0
13:12	Reserved ^a	–	–	00
11	FDX Mask	R/W	Full-duplex interrupt mask	1
10	SPD Mask	R/W	SPEED interrupt mask	1
9	LINK Mask	R/W	LINK interrupt mask	1
8	INTR Mask	R/W	Master interrupt mask	1
7:5	Reserved ^a	–	–	000
4	Global Interrupt Indicator	RO	1= Indicates an interrupt is present within the BCM5228	0
3	FDX Change	RO, LH	Duplex change interrupt	0
2	SPD Change	RO, LH	Speed change interrupt	0
1	LINK Change	RO, LH	Link change interrupt	0
0	INTR Status	RO, LH	Interrupt status	0

Note: R/W = Read/Write, RO = Read Only, SC = Self Clear, LL = Latched Low, LH = Latched High, LL and LH Clear after read operation.

a. Preserve existing values of reserved bits by completing a “Read/Modify Write.”

FDX LED Enable. Setting this bit enables the FDX LED status to output serial LED data in serial LED mode. See [Table 6 on page 27](#) for details.

INTR Enable. Setting this bit enables Interrupt mode. The state of this bit also affects which status signals are shifted out on the serial LED data in Serial LED mode. See [Table 6 on page 27](#) for details.

FDX Mask. When this bit is set, changes in duplex mode do not generate an interrupt.

SPD Mask. When this bit is set, changes in operating speed do not generate an interrupt.

LINK Mask. When this bit is set, changes in link status do not generate an interrupt.

INTR Mask. Master interrupt mask. When this bit is set, no interrupts are generated regardless of the state of the other mask bits.

Global Interrupt Indicator. A 1 indicates an Interrupt is present within the BCM5228.

FDX Change. A 1 indicates a change of duplex status since last register read. A register read clears the bit.

SPD Change. A 1 indicates a change of speed status since last register read. A register read clears the bit.

LINK Change. A 1 indicates a change of link status since last register read. A register read clears the bit.

INTR Status. Represents status of the INTR# pin. A 1 indicates that the interrupt mask is off and that one or more of the change bits are set. A register read clears the bit.

AUXILIARY MODE 2 REGISTER

Table 35: Auxiliary Mode 2 Register (Address 27d, 1Bh)

Bit	Name	R/W	Description	Default
15:12	Reserved ^a	–	–	0
11	10BASE-T Dribble Bit Correct	R/W	1 = Enable 0 = Disable	0
10	Jumbo Packet Enable	R/W	1 = Enable 0 = Disable	0
9	Jumbo Packet FIFO Enable	R/W	1 = Enable 0 = Disable	0
8	Reserved ^a	–	–	0
7	Block 10BASE-T Echo Mode	R/W	1 = Enable 0 = Disable	1
6	Traffic Meter LED Mode	R/W	1 = Enable 0 = Disable	0
5	Activity LED Force On	R/W	1 = On 0 = Normal operation	0
4	Reserved ^a	–	–	1
3	Reserved ^a	–	–	1
2	Activity/Link LED Mode	R/W	1 = Enable 0 = Disable	0
1	Qual Parallel Detect Mode	R/W	1 = Enable 0 = Disable	1
0	Reserved ^a	–	–	0

Note: R/W = Read/Write, RO = Read Only, SC = Self Clear, LL = Latched Low, LH = Latched High, LL and LH Clear after read operation.

a. Preserve existing values of reserved bits by completing a “Read/Modify Write.”

10BASE-T Dribble Bit Correct. When enabled, the PHY rounds-down to the nearest nibble when dribble bits are present on the 10BASE-T input stream.

Jumbo Packet Enable. When enabled, the 100BASE-X unlock timer changes to allow long packets. See [Table 5 on page 25](#) for details.

Jumbo Packet FIFO Enable. When enabled, the RMII/SMII/S3MII receive FIFO doubles from 7 nibbles to 14 nibbles. The Jumbo Packet FIFO Enable bit should be set to a 1 when jumbo packet mode is enabled. See [Table 4 on page 25](#) and [Table 5 on page 25](#) for details.

Block 10BASE-T Echo Mode. When enabled, during 10BASE-T half-duplex transmit operation, the TXEN signal does not echo onto the RXDV pin. The TXEN echoes onto the CRS pin, and the CRS deassertion directly follows the TXEN deassertion.

Traffic Meter LED Mode. When enabled, the Activity LEDs (ACTLED# and FDXLED# if full-duplex LED and interrupt LED modes are not enabled) do not blink based on the internal LED clock (approximately 80 μ s of time). Instead, they blink based on the rate of receive and transmit activity. Each time a receive or transmit operation occurs, the LED turns on for a minimum of 5 μ s. During light traffic, the LED blinks at a low rate, while during heavier traffic the LEDs remain on.

Activity LED Force On. When set to 1, the Col LED, Transmit LED, Receive LED, and Activity LED are turned on. This bit has a higher priority than the Activity LED Force Inactive, bit 4, register 1Dh.

Activity/Link LED Mode. When enabled, the receive output goes active upon acquiring link and pulses during receive or transmit activity.

Qual Parallel Detect Mode. This bit allows the auto-negotiation/parallel detection process to be qualified with information in the Advertisement register.

If this bit is not set, the local BCM5228 device is enabled to auto-negotiate, and the far-end device is a 10BASE-T or 100BASE-X non auto-negotiating legacy type, the local device auto-negotiates/parallel-detects the far-end device, regardless of the contents of its Advertisement register (04h).

If this bit is set, the local device compares the link speed detected to the contents of its Advertisement register. If the particular link speed is enabled in the Advertisement register, the local device asserts link. If the link speed is disabled in this register, then the local device does not assert link and continues monitoring for a matching capability link speed.

10BASE-T AUXILIARY ERROR AND GENERAL STATUS REGISTER

Table 36: 10BASE-T Auxiliary Error and General Status Register (Address 28d, 1Ch)

Bit	Name	R/W	Description	Default
15:14	Reserved ^a	–	–	0
13	MDIX Status	RO	0 = MDI is in use 1 = MDIX is in use	0
12	MDIX Manual Swap	R/W	0 = MDI or MDIX if MDIX is not disabled 1 = Force MDIX	0
11	HP Auto-MDIX Disable	R/W	0 = Enable HP auto-MDIX 1 = Disable HP auto-MDIX	0
10	Manchester Code Error	RO	1 = Manchester code error (10BASE-T)	0
9	End-of-Frame Error	RO	1 = EOF detection error (10BASE-T)	0
8	Reserved ^a	–	–	0
7:5	Reserved ^a	–	–	001
4	Reserved ^a	–	–	0
3	Auto-Negotiation Indication	RO	1 = Auto-negotiation activated 0 = Speed forced manually	1
2	Force 100/10 Indication	RO	1 = Speed forced to 100BASE-X 0 = Speed forced to 10BASE-T	1
1	Speed Indication	RO	1 = 100BASE-X 0 = 10BASE-T	0
0	Full-Duplex Indication	RO	1 = Full-duplex active 0 = Full-duplex not active	0

Note: R/W = Read/Write, RO = Read Only, SC = Self Clear, LL = Latched Low, LH = Latched High, LL and LH Clear after read operation.

a. Preserve existing values of reserved bits by completing a “Read/Modify Write.”

All Error bits in the Auxiliary Error and General Status register are read-only and are latched high. When certain types of errors occur in the BCM5228, one or more corresponding error bits become 1. They remain so until the register is read, or

until a chip reset occurs. All such errors necessarily result in data errors, and are indicated by a high value on the RXER output pin at the time the error occurs.

MDIX Status. This bit, when read as a 1, indicates that the MDI TD \pm and RD \pm signals for the BCM5228 have been swapped. The cause for this is one of the following:

- the MDIX Swap bit was manually set to a 1, or
- the HP Auto-MDIX function is enabled and the BCM5228 has detected an MDI cross-over cable.

MDIX Manual Swap. When this bit is set to a 1, the MDI TD \pm and RD \pm signals for the BCM5228 are forced into being swapped.

HP Auto-MDIX Disable. When this bit is set to a 1, the HP Auto-MDIX function is disabled in the BCM5228.

Manchester Code Error. Indicates that a Manchester code violation was received. This bit is only valid during 10BASE-T operation.

End-of-Frame Error. Indicates that the end-of-frame (EOF) sequence was improperly received, or not received at all. This error bit is only valid during 10BASE-T operation.

Auto-Negotiation Indication. A read-only bit that indicates whether auto-negotiation has been enabled or disabled on the BCM5228. A combination of a 1 in bit 12 of the Control register and a logic 1 on the ANEN input pin is required to enable auto-negotiation. When auto-negotiation is disabled, bit 15 of the Auxiliary Mode register returns a 0. At all other times, it returns a 1.

Force 100/10 Indication. A read-only bit that returns a value of 0 when one of following two cases is true:

- The ANEN pin is low AND the F100 pin is low, or
- Bit 12 of the Control register has been written 0 AND bit 13 of the Control register has been written 0.

When bit 2 of the Auxiliary Control register is 0, the speed of the chip is 10BASE-T. In all other cases, either the speed is not forced (auto-negotiation is enabled), or the speed is forced to 100BASE-X.

Speed Indication. A read-only bit that shows the true current operation speed of the BCM5228. A 1 bit indicates 100BASE-X operation, while a 0 indicates 10BASE-T. While the auto-negotiation exchange is performed, the BCM5228 is always operating at 10BASE-T speed.

Full-Duplex Indication. A read-only bit that returns a 1 when the BCM5228 is in full-duplex mode. In all other modes, it returns a 0.

AUXILIARY MODE REGISTER

Table 37: Auxiliary Mode Register (Address 29d, 1Dh)

Bit	Name	R/W	Description	Default
15:5	Reserved ^a	–	–	000h
4	Activity LED Force Inactive	R/W	1 = Disable Col LED, Transmit LED, Receive LED, and Activity LED 0 = Enable above LEDs	0
3	Link LED Disable	R/W	1 = Disable link LED output 0 = Enable link LED output	0
2	Reserved ^a	–	–	0
1	Block TXEN Mode	R/W	1 = Enable block TXEN mode 0 = Disable block TXEN mode	0
0	Reserved ^a	–	–	0

Note: R/W = Read/Write, RO = Read Only, SC = Self Clear, LL = Latched Low, LH = Latched High, LL and LH Clear after read operation.

a. Preserve existing values of reserved bits by completing a Read/Modify Write.

Activity LED Force Inactive. When set to 1, disables the Col LED, Transmit LED, Receive LED, and Activity LED. This bit has a lower priority than the Activity LED Force On, bit 5 of register 1Bh.

Link LED Disable. When set to 1, disables the Link LED output pin. When 0, Link LED output is enabled.

Block TXEN Mode. When this mode is enabled, short IPGs of 1, 2, 3, or 4 TXC cycles all result in the insertion of two idles before the beginning of the next packet's JK symbols.

AUXILIARY MULTIPLE PHY REGISTER

Table 38: Auxiliary Multiple PHY Register (Address 30d, 1Eh)

Bit	Name	R/W	Description	Default
15	HCD_TX_FDX	RO	1 = Auto-negotiation result is 100BASE-TX full-duplex	0
14	HCD_T4	RO	1 = Auto-negotiation result is 100BASE-T4	0
13	HCD_TX	RO	1 = Auto-negotiation result is 100BASE-TX	0
12	HCD_10BASE-T_FDX	RO	1 = Auto-negotiation result is 10BASE-T full-duplex	0
11	HCD_10BASE-T	RO	1 = Auto-negotiation result is 10BASE-T	0
10:9	Reserved ^a	–	–	00
8	Restart Auto-Negotiation	R/W (SC)	1 = Restart auto-negotiation process 0 = No effect	0
7	Auto-Negotiation Complete	RO	1 = Auto-negotiation process completed 0 = Auto-negotiation process not completed	0
6	Acknowledge Complete	RO	1 = Auto-negotiation acknowledge completed	0
5	Acknowledge Detected	RO	1 = Auto-negotiation acknowledge detected	0
4	Ability Detect	RO	1 = Auto-negotiation waiting for LP ability	0
3	Super Isolate	R/W	1 = Super isolate mode 0 = Normal operation	0
2	Reserved ^a	–	–	0
1	10BASE-T Serial Mode	R/W	1 = Enable 10BASE-T serial mode 0 = Disable 10BASE-T serial mode	0
0	Reserved ^a	–	–	0

Note: R/W = Read/Write, RO = Read Only, SC = Self Clear, LL = Latched Low, LH = Latched High, LL and LH Clear after read operation.

a. Preserve existing values of reserved bits by completing a “Read/Modify Write.”

HCD. Bits 15:11 of the Auxiliary Multiple PHY register are 5 read-only bits that report the highest common denominator (HCD) result of the auto-negotiation process. Immediately upon entering the Link Pass state after each reset or restart auto-negotiation, only 1 of these 5 bits is 1. The Link Pass state is identified by a 1 in bit 6 or 7 of this register. The HCD bits are reset to 0 every time auto-negotiation is restarted or the BCM5228 is reset.

For their intended application, these bits uniquely identify the HCD only after the first link pass after reset or restart of auto-negotiation. If the ability of the link partner is different on later link fault and subsequent renegotiations, more than one of the above bits may be active.

Restart Auto-Negotiation. A self-clearing bit that allows the auto-negotiation process to be restarted, regardless of the current status of the state machine. For this bit to work, auto-negotiation must be enabled. Writing a 1 to this bit restarts auto-negotiation. Because the bit is self-clearing, it always returns a 0 when read. The operation of this bit is identical to bit 9 of the Control register.

Auto-Negotiation Complete. This read-only bit returns a 1 after the auto-negotiation process has been completed. It remains 1 until the auto-negotiation process is restarted, a link fault occurs, or the chip is reset. If auto-negotiation is disabled or the process is still in progress, the bit returns a 0.

Acknowledge Complete. This read-only bit returns a 1 after the acknowledgment exchange portion of the auto-negotiation process has been completed and the arbitrator state machine has exited the acknowledge complete state. It remains this value until the auto-negotiation process is restarted, a link fault occurs, auto-negotiation is disabled, or the BCM5228 is reset.

Acknowledge Detected. This read-only bit is set to 1 when the arbitrator state machine exits the acknowledge detect state. It remains high until the auto-negotiation process is restarted, or the BCM5228 is reset.

Ability Detect. This read-only bit returns a 1 when the auto-negotiation state machine is in the ability detect state. It enters this state a specified time period after the auto-negotiation process begins, and exits after the first FLP burst or link pulses are detected from the link partner. This bit returns a 00 any time the auto-negotiation state machine is not in the ability detect state.

Super Isolate. Writing a 1 to this bit places the BCM5228 into the super isolate mode. Similar to the isolate mode, all RMII/SMII/S3MII inputs are ignored, and all RMII/SMII/S3MII outputs are tri-stated. Additionally, all link pulses are suppressed. This allows the BCM5228 to coexist with another PHY on the same adapter card, with only one being activated at any time. See also “[Super Isolate Mode](#)” on page 24.

10BASE-T Serial Mode. Writing a 1 to bit 1 of the Auxiliary Mode register enables the 10BASE-T Serial mode. In 10BASE-T Serial mode, data packets traverse to the MAC layer across only TXD0 and RXD0 at a rate of 10 MHz. Serial operation is not available in 100BASE-X mode.

BROADCOM TEST REGISTER

Table 39: Broadcom Test (Address 31d, 1Fh)

Bit	Name	R/W	Description	Default
15:8	Reserved ^a	–	–	00h
7	Shadow Register Enable	R/W	1 = Enable shadow registers 1Ah-1Eh 0 = Disable shadow registers	0
6	Reserved ^a	–	–	0
5	Reserved ^a	–	–	0
4:0	Reserved ^a	–	–	0Bh

Note: R/W = Read/Write, RO = Read Only, SC = Self Clear, LL = Latched Low, LH = Latched High, LL and LH Clear after read operation.

a. Preserve existing values of reserved bits by completing a “Read/Modify Write.”

Shadow Register Enable. Writing a 1 to bit 7 of register 1Fh allows R/W access to the shadow registers.

AUXILIARY MODE 4 (PHY 1) REGISTER (SHADOW REGISTER)

Table 40: Auxiliary Mode 4 (PHY 1) Register (Shadow Register 26d, 1Ah)

Bit	Name	R/W	Description	Default
15:9	Reserved ^a	–	–	0011 000b
8	MII LED Select Enable	R/W	1 = Enable LED output selection through MII register	0
7:6	Parallel LED3 Select[1:0]	R/W	Configuration bits for LED3 output. For details, see “LED Modes” on page 27.	TXER/LED1[7:6] ^b
5:3	Parallel LED2 Select[2:0]	R/W	Configuration bits for LED2 output. For details, see “LED Modes” on page 27.	TXER/LED1[5:3]
2:0	Parallel LED1 Select[2:0]	R/W	Configuration bits for LED1 output. For details, see “LED Modes” on page 27.	TXER/LED1[2:0]

Note: R/W = Read/Write, RO = Read Only, SC = Self Clear, LL = Latched Low, LH = Latched High, LL and LH Clear after read operation. MII Shadow register bank 1 is accessed by setting MII register 1Fh bit 7 to a 1.

- Preserve existing values of reserved bits by completing a “Read/Modify Write.”
- Status of TXER/LED1[7:0] during power-on reset determines the default values for parallel LED3, LED2 and LED1 selects.

MII LED Select Enable. Enables configuration of LED functions through MII register writes when this bit is set to a 1. Otherwise, power-on reset configurations are in effect.

Parallel LED3 Select[1:0]. Bit 7 and 6 select LED output for the parallel LED3 pin if MII LED select enable is set to a 1.

Parallel LED2 Select[2:0]. Bit 5 and 3 select LED output for the parallel LED2 pin if MII LED select enable is set to a 1.

Parallel LED1 Select[2:0]. Bit 2 and 0 select LED output for the parallel LED1 pin if MII LED select enable is set to a 1.

AUXILIARY MODE 4 (PHY 2) REGISTER (SHADOW REGISTER)

Table 41: Auxiliary Mode 4 (PHY 2) Register (Shadow Register 26d, 1Ah)

Bit	Name	R/W	Description	Default
15:9	Reserved ^a	–	–	0011 000b
8:6	Serial Bank 6 Select[2:0]	R/W	Configuration bits for bank 6 output in low-cost serial LED mode. For details, see “LED Modes” on page 27.	000
5:3	Serial Bank 5 Select[2:0]	R/W	Configuration bits for bank 5 output in low-cost serial LED mode. For details, see “LED Modes” on page 27.	000
2:0	Serial Bank 4 Select[2:0]	R/W	Configuration bits for bank 4 output in low-cost serial LED mode. For details, see “LED Modes” on page 27.	000

Note: R/W = Read/Write, RO = Read Only, SC = Self Clear, LL = Latched Low, LH = Latched High, LL and LH Clear after read operation. MII Shadow register bank 1 is accessed by setting MII register 1Fh bit 7 to a 1.

a. Preserve existing values of reserved bits by completing a “Read/Modify Write.”

Serial Bank 6 Select[2:0]. If low-cost serial LED mode is selected, these bits configure bank 6 LED output on the serial LED data stream SLED_DO.

Serial Bank 5 Select[2:0]. If low-cost serial LED mode is selected, these bits configure bank 5 LED output on the serial LED data stream SLED_DO.

Serial Bank 4 Select [2:0]. If low-cost serial LED mode is selected, these bits configure bank 4 LED output on the serial LED data stream SLED_DO.

AUXILIARY MODE 4 (PHY 3) REGISTER (SHADOW REGISTER)

Table 42: Auxiliary Mode 4 (PHY 3) Register (Shadow Register 26d, 1Ah)

Bit	Name	R/W	Description	Default
15:9	Reserved ^a	–	–	0011 000b
8:6	Serial Bank 3 Select[2:0]	R/W	Configuration bits for bank 3 output in low-cost serial LED mode. For details, see “LED Modes” on page 27.	000
5:3	Serial Bank 2 Select[2:0]	R/W	Configuration bits for bank 2 output in low-cost serial LED mode. For details, see “LED Modes” on page 27.	000
2:0	Serial Bank 1 Select[2:0]	R/W	Configuration bits for bank 1 output in low-cost serial LED mode. For details, see “LED Modes” on page 27.	000

Note: R/W = Read/Write, RO = Read Only, SC = Self Clear, LL = Latched Low, LH = Latched High, LL and LH Clear after read operation. MII Shadow register bank 1 is accessed by setting MII register 1Fh bit 7 to a 1.

a. Preserve existing values of reserved bits by completing a “Read/Modify Write.”

Serial Bank 3 Select[2:0]. If low-cost serial LED mode is selected, these bits configure bank 6 LED output on serial LED data stream SLED_DO.

Serial Bank 2 Select[2:0]. If low-cost serial LED mode is selected, these bits configure bank 5 LED output on serial LED data stream SLED_DO.

Serial Bank 1 Select[2:0]. If low-cost serial LED mode is selected, these bits configure bank 4 LED output on serial LED data stream SLED_DO.



AUXILIARY STATUS 2 REGISTER (SHADOW REGISTER)

Table 43: Auxiliary Status 2 Register (Shadow Register 27d, 1Bh)

Bit	Name	R/W	Description	Default
15	MLT3 Detected	R/O	1 = MLT3 detected	0
14:12	Cable Length 100X[2:0]	R/O	The BCM5228 shows the cable length in 20-meter increments, as shown in Table 44 .	000
11:6	ADC Peak Amplitude[5:0]	R/O	A to D peak amplitude seen	00h
5	APD Enable	R/W	0 = Normal mode 1 = Enable auto power-down mode	0
4	APD Sleep Timer	R/W	0 = 2.5-second sleep before wake up 1 = 5.0-second sleep before wake up	0
3:0	APD Wake-Up Timer[3:0]	R/W	Duration of wake up	0001

Note: R/W = Read/Write, RO = Read Only, SC = Self Clear, LL = Latched Low, LH = Latched High, LL and LH Clear after read operation. MII Shadow register bank 1 is accessed by setting MII register 1Fh bit 7 to a 1.

MLT3 Detected. The BCM5228 returns a 1 in this bit whenever MLT3 signaling is detected.

Cable Length 100X [2:0]. The BCM5228 provides the cable length for each port when a 100TX link is established.

Table 44: Cable Length

Cable Length 100x [2:0]	Cable Length in Meters
000	< 20
001	20 to <40
010	40 to <60
011	60 to < 80
100	80 to < 100
101	100 to < 120
110	120 to < 140
111	> 140

ADC Peak Amplitude [5:0]. The BCM5228 returns the A to D converter's 6-bit peak amplitude seen during this link.

APD Enable. When in normal mode, if this bit is set to a 1, the BCM5228 enters auto power-down mode. If this bit is set and the link is lost, the BCM5228 enters low power-down mode. When energy is detected, the device enters full power mode. Otherwise, it wakes up after either 2.5 seconds or 5.0 seconds, as determined by the APD Sleep Timer bit. When the BCM5228 wakes up, it sends link pulses and also monitors energy. If the link partner's energy is detected, the BCM5228 device continues to stay in wake-up mode for a duration determined by the APD wake-up timer before going to low power mode.

APD Sleep Timer. This bit determines how long the BCM5228 stays in low power mode before waking up. If this bit is a 0, the BCM5228 device waits approximately 2.5 seconds before waking up. Otherwise, it wakes up after approximately 5.0 seconds.

APD Wake-Up Timer[3:0]. This counter determines how long the BCM5228 stays in wake-up mode before going to low power mode. This value is specified in 40-millisecond increments from 0 to 600 milliseconds. A value of 0 forces the BCM5228 to stay in low power mode indefinitely. In this case, the BCM5228 requires a hard reset to return to normal mode.

AUXILIARY STATUS 3 REGISTER (SHADOW REGISTER)

Table 45: Auxiliary Status 3 Register (Shadow Register 28d, 1Ch)

<i>Bit</i>	<i>Name</i>	<i>R/W</i>	<i>Description</i>	<i>Default</i>
15:8	Noise [7:0]	R/O	Current mean square error value, valid only if link is established	00h
7:4	Reserved ^a	–	–	000h
3:0	FIFO Consumption [3:0]	R/O	Currently used number of nibbles in the receive FIFO	0000

Note: MII Shadow register bank 1 is accessed by setting MII register 1Fh bit 7 to a 1.

- a. Preserve existing values of reserved bits by completing a “Read/Modify Write.”

Noise[7:0]. The BCM5228 provides the current mean squared error value for noise when a valid link is established.

FIFO Consumption[3:0]. The BCM5228 indicates the number of nibbles of FIFO currently used.

AUXILIARY MODE 3 REGISTER (SHADOW REGISTER)

Table 46: Auxiliary Mode 3 Register (Shadow Register 29d, 1Dh)

Bit	Name	R/W	Description	Default
15:9	Reserved ^a	–	–	0
8	Reserved ^a	–	–	0
7	Reserved ^a	–	–	0
6	Reserved ^a	–	–	0
5:4	Reserved ^a	–	–	0h
3:0	FIFO Size Select [3:0]	R/W	Currently-selected receive FIFO size	4h

Note: R/W = Read/Write, RO = Read Only, SC = Self Clear, LL = Latched Low, LH = Latched High, LL and LH Clear after read operation. MII Shadow register bank 1 is accessed by setting MII register 1Fh bit 7 to a 1.

a. Preserve existing values of reserved bits by completing a “Read/Modify Write.”

FIFO Size Select[3:0]. The BCM5228 indicates the current selection of receive FIFO size using bit 3 through 0, as shown in [Table 47](#). The size can also be determined by the Extended FIFO Enable bit (register 10h, bit 2) and the Jumbo Packet FIFO Enable bit (register 1Bh, bit 9) for backward compatibility with the 0.35-micron products.

Table 47: Current Receive FIFO Size

FIFO Size Select[3:0]	Receive Fifo size in Use (# of bits)
0000	12
0001	16
0010	20
0011	24
0100	28
0101	32
0110	36
0111	40
1000	44
1001	48
1010	52
1011	56
1100	60
1101	64

AUXILIARY STATUS 4 REGISTER (SHADOW REGISTER)

Table 48: Auxiliary Status 4 Register (Shadow Register 30d, 1Eh)

<i>Bit</i>	<i>Name</i>	<i>R/W</i>	<i>Description</i>	<i>Default</i>
15:0	Packet Length Counter[15:0]	R/O	Number of bytes in the last received packet	0000h

Packet Length Counter[15:0]. The BCM5228 shows the number bytes in the last packet received. This is valid only when a valid link is established.



Section 7: Timing and AC Characteristics

All digital output timing is specified at $C_L = 30$ pF.

Output rise/fall times are measured between 10% and 90% of the output signal swing. Input rise/fall times are measured between V_{IL} maximum and V_{IH} minimum. Output signal transitions are referenced to the midpoint of the output signal swing. Input signal transitions are referenced to the midpoint between V_{IL} maximum and V_{IH} minimum.

Table 49: Clock Timing

Parameter	Symbol	Min	Typ	Max	Unit
REF_CLK cycle time (50-MHz operation)	CK_CYCLE	–	20	–	ns
REF_CLK cycle time (125-MHz operation)	CK_CYCLE	–	8	–	ns
REF_CLK high/low time (50-MHz operation)	CK_HI CK_LO	7	10	13	ns
REF_CLK high/low time (125-MHz operation)	CK_HI CK_LO	–	4	–	ns
REF_CLK rise/fall time (50-MHz operation)	CK_EDGE	–	–	2	ns
REF_CLK rise/fall time (125-MHz operation)	CK_EDGE	–	–	1	ns

Table 50: Reset Timing

Parameter	Symbol	Min	Typ	Max	Unit
Reset pulse length with stable REF_CLK input	RESET_LEN	2	–	–	μ s
Activity after end of reset	RESET_WAIT	100	–	–	μ s
RESET rise/fall time	RESET_EDGE	–	–	10	ns

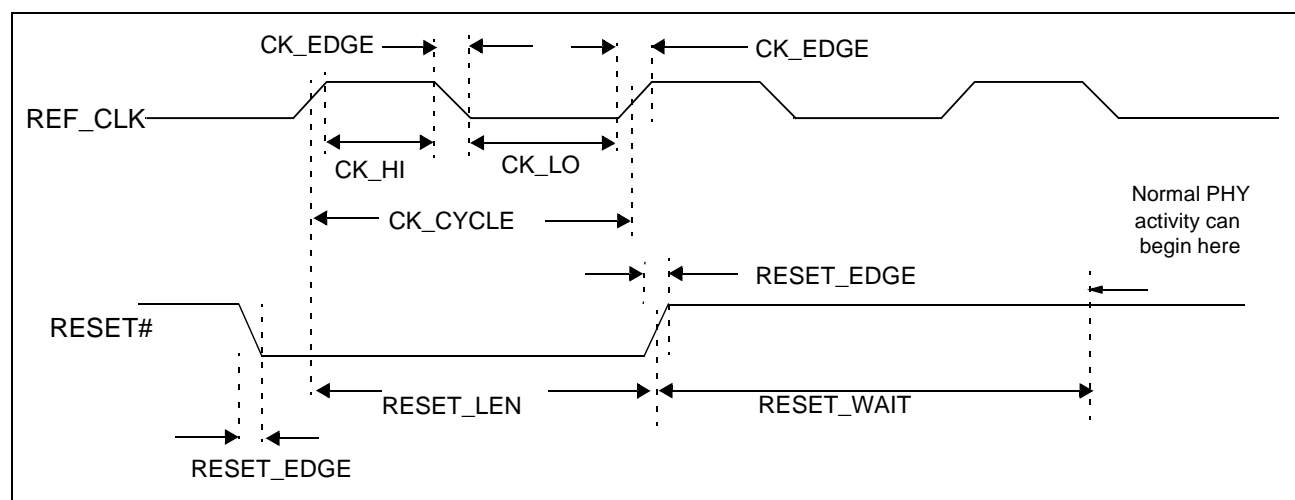

Figure 5: Clock and Reset Timing

Table 51: RMII Transmit Timing

Parameter	Symbol	Min	Typ	Max	Unit
REF_CLK cycle time	REF_CLK	–	20	–	ns
TXEN, TX_ER, TXD[1:0] setup time to REF_CLK rising	TXEN_SETUP	4	–	–	ns
TXEN, TX_ER, TXD[1:0] hold time from REF_CLK rising	TXEN_HOLD	2	–	–	ns
TD± after TXEN assert	TXEN_TDATA	–	89	–	ns
TXD to TD± steady state delay	TXD_TDATA	–	95	–	ns

Note: TXD[1:0] shall provide valid data for each REF_CLK period while TX_EN is asserted. As the REF_CLK frequency is 10 times the data rate in 10MB/s mode, the value on TXD[1:0] shall be valid such that TXD[1:0] can be sampled every 10th cycle, regardless of the starting cycle within the group and yield the correct frame data.

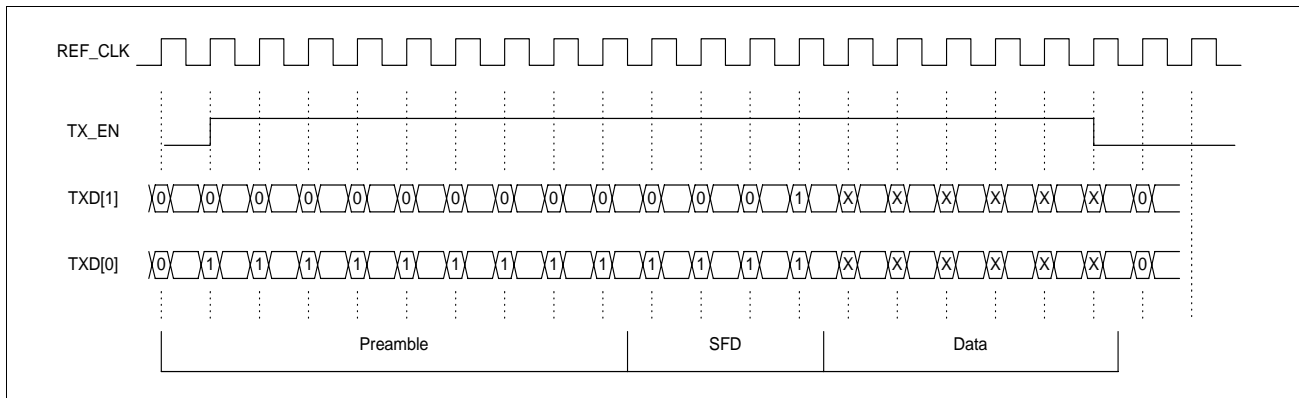

Figure 6: RMII Transmit Packet Timing

Table 52: RMII Receive Timing

Parameter	Symbol	Min	Typ	Max	Unit
REF_CLK cycle time	REF_CLK	–	20	–	ns
RXD[1:0], CRS, DV, RX_ER output delay from REF_CLK rising	–	2	–	16	ns
CRS_DV assert after RD±	RX_CRS_DV	–	124	–	ns
CRS_DV deassert after RD±	RX_CRS_DV	–	164	–	ns
CRS_DV deassert after RD±, valid EOP	RX_CRS_DV_EOP	–	237	–	ns

Note: As the REF_CLK frequency is 10 times the data rate in 10 Mbps mode, the value on RXD[1:0] is valid such that RXD[1:0] can be sampled every 10th cycle, regardless of the starting cycle within the group and yield the correct frame data. The receiver accounts for differences between the local REF_CLK and the recovered clock through use of sufficient elasticity buffering. The output delay has a load of 25 pf, which accommodates a PCB trace length of over 12 inches.



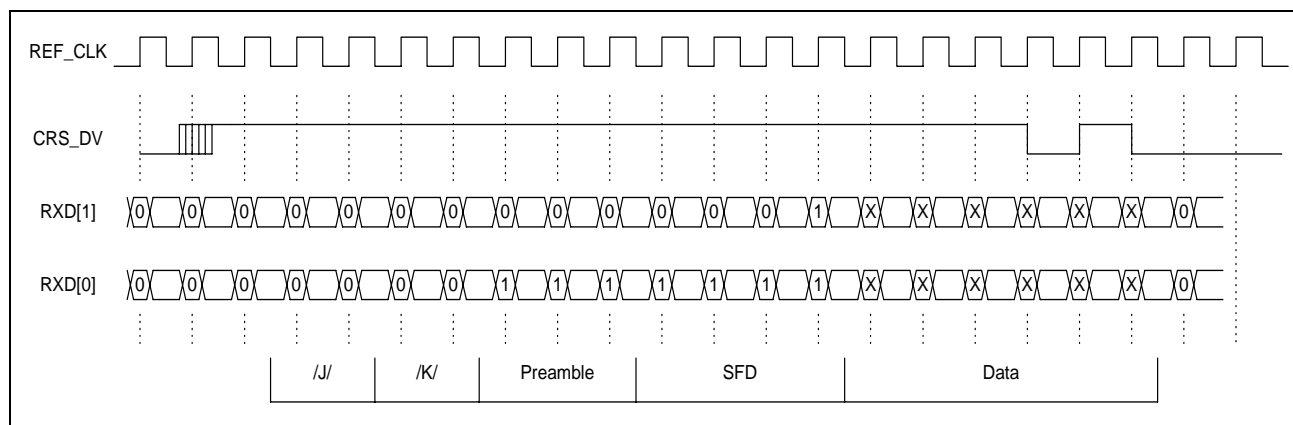

Figure 7: RMI Receive Packet Timing

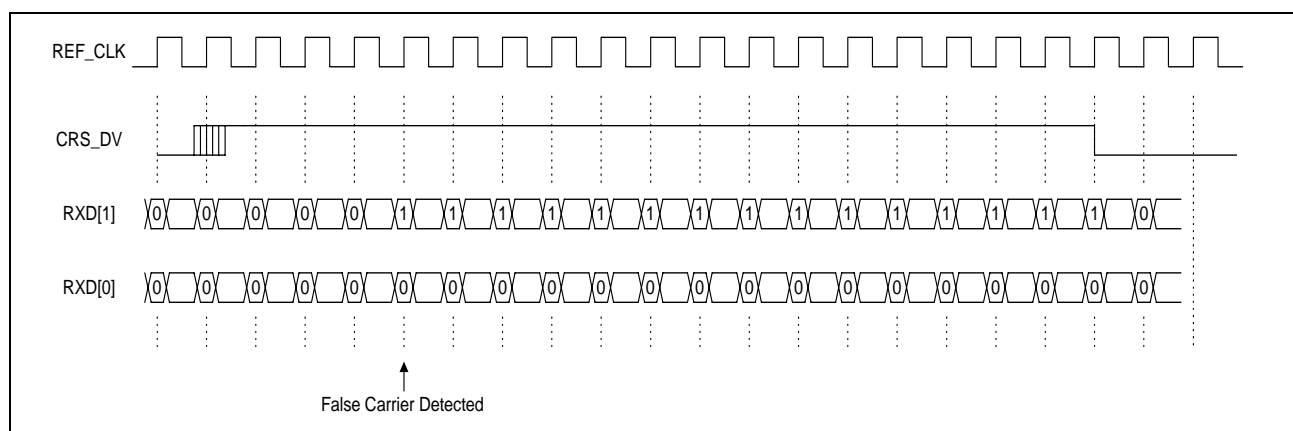

Figure 8: RMI Receive Packet with False Carrier

Table 53: SMII/S3MII Timing

Parameter	Symbol	Min	Typ	Max	Unit
STX (TXD) setup (SCLK rising)	STX_SETUP	1.5	–	–	ns
STX (TXD) hold (SCLK rising)	STX_HOLD	1.0	–	–	ns
SYNC (SSYNC) setup (SCLK rising)	SYNC_SETUP	1.5	–	–	ns
SYNC (SSYNC) hold (SCLK rising)	SYNC_HOLD	1.0	–	–	ns
SRX (RXD) delay (SCLK rising)	SRX_DELAY	2.0	–	5.0	ns
SMII_RSYNC delay	SYNC_DELAY	2.0	–	5.0	ns

Note: SCLK is REF_CLK in SMII mode
SCLK is SMII_TXC for S3MII STX
SCLK is SMII_RXC for S3MII SRX

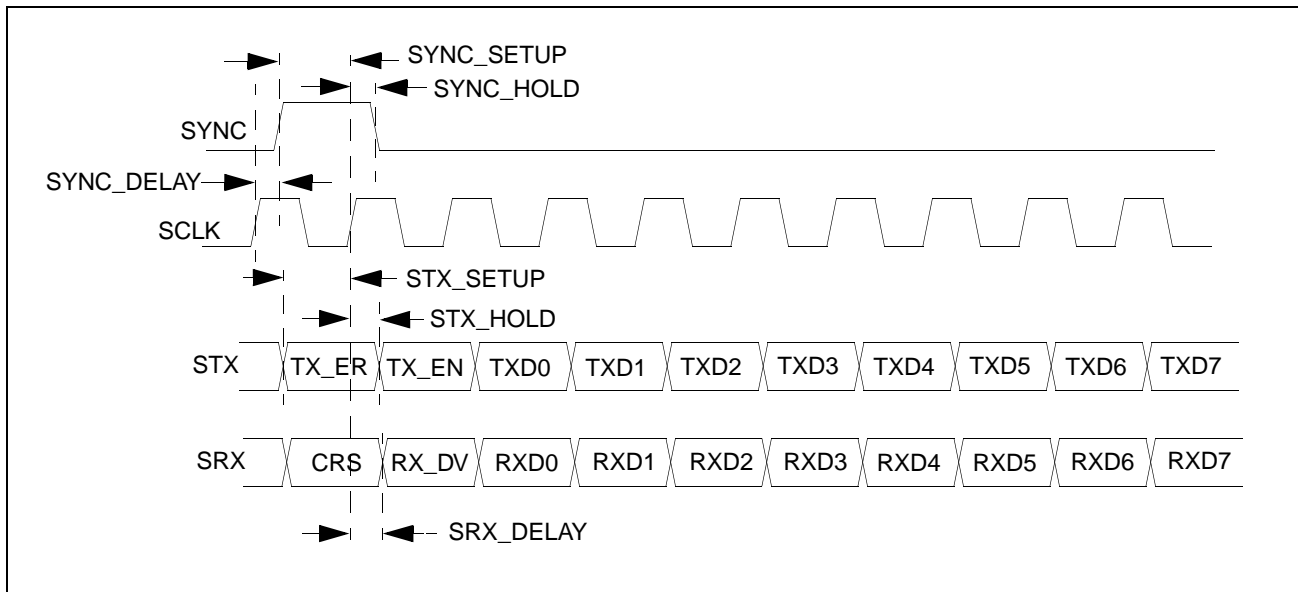

Figure 9: SMII/S3MII Timing

Table 54: Auto-Negotiation Timing

Parameter	Symbol	Min	Typ	Max	Unit
Link test pulse width	-	-	100	-	ns
FLP burst interval	-	5.7	16	22.3	ms
Clock pulse to clock pulse	-	111	123	139	µs
Clock pulse to data pulse (data = 1)	-	55.5	62.5	69.5	µs

Table 55: LED Timing

Parameter	Symbol	Min	Typ	Max	Unit
LED on time (ACTLED)	-	-	80	-	ms
LED off time (ACTLED)	-	-	80	-	ms

Table 56: MII Management Data Interface Timing

Parameter	Symbol	Min	Typ	Max	Unit
MDC cycle time	-	40	-	-	ns
MDC high/low	-	20	-	-	ns
MDC rise/fall time	-	-	-	10	ns
MDIO input setup time to MDC rising	-	10	-	-	ns
MDIO input hold time from MDC rising	-	10	-	-	ns
MDIO output delay from MDC rising	-	0	-	30	ns



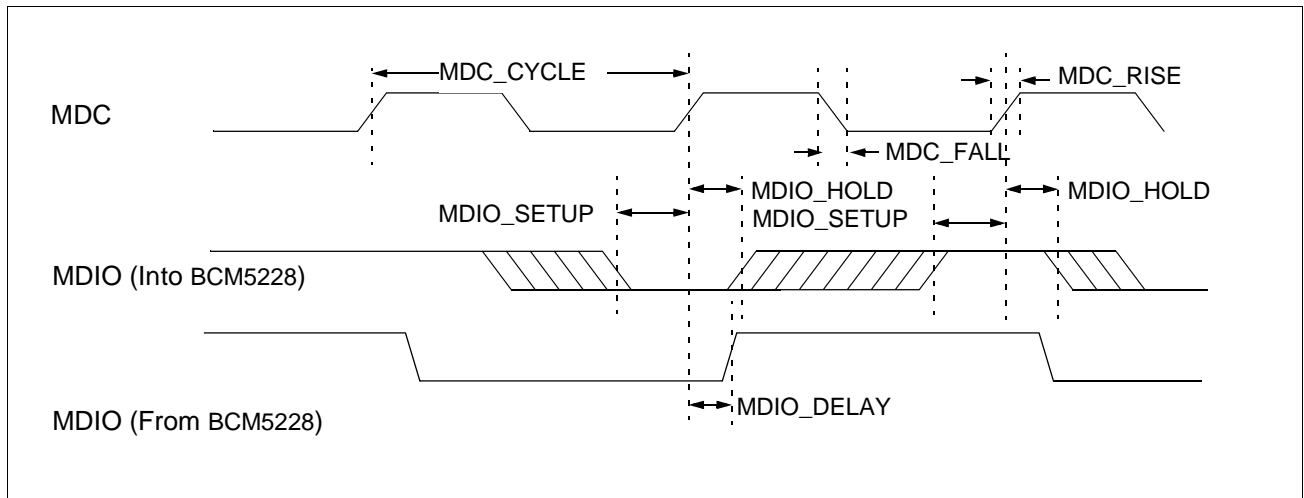

Figure 10: Management Interface Timing

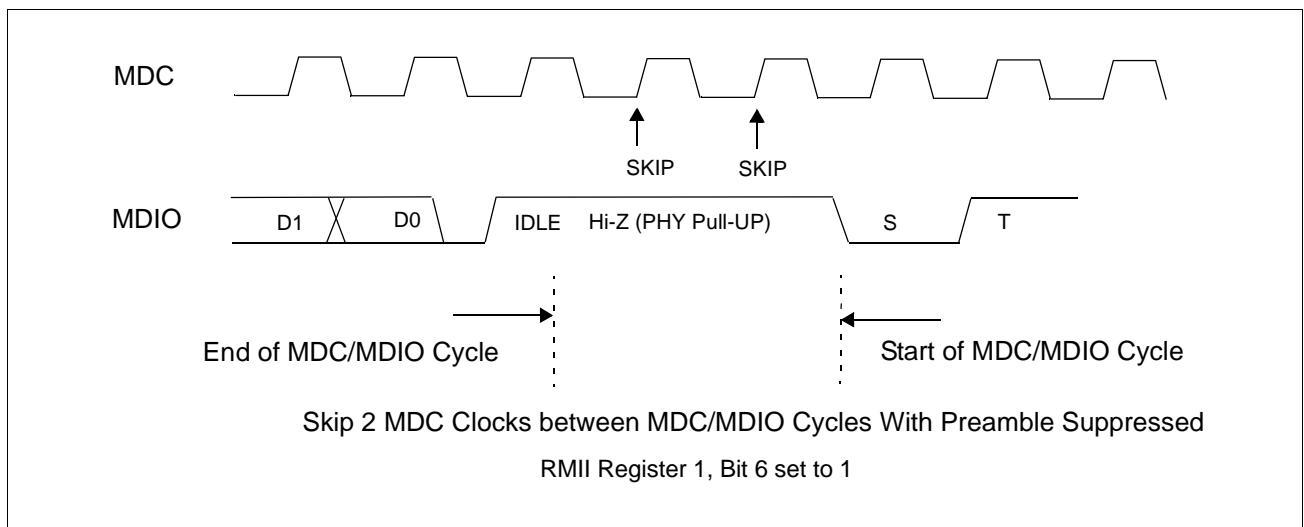

Figure 11: Management Interface Timing (with Preamble Suppression On)



Section 8: Electrical Characteristics

Table 57: Absolute Maximum Ratings

Symbol	Parameter	Min	Max	Units
V _{DD}	Supply voltage	GND – 0.3	2.75	V
V _I	Input voltage	GND – 0.3	OVDD + 0.3	V
I _I	Input current	–	±10	mA
T _{STG}	Storage temperature	–40	+125	°C
V _{ESD}	Electrostatic discharge	–	1000	V

Note: These specifications indicate levels where permanent damage to the device can occur. Functional operation is not guaranteed under these conditions. Operation at absolute maximum conditions for extended periods can adversely affect long-term reliability of the device.

Table 58: Recommended Operating Conditions

Symbol	Parameter	Pins	Operating Mode	Min	Max	Units
V _{DD}	Supply voltage	OVDD	–	2.375	3.465	V
V _{DD}	Supply voltage	AVDD, DVDD, PLLVDD, BIASVDD	–	2.375	2.625	V
V _{IH}	High-level input voltage	All digital inputs	–	2.0		V
V _{IL}	Low-level input voltage	All digital inputs	–		0.8	V
		SD± {1:8}	100BASE-FX		0.4	V
V _{IDIFF}	Differential input voltage	SD± {1:8}	100BASE-FX	150	–	mV
V _{ICM}	Common mode input voltage	RD± {1:8}	100BASE-TX	1.85	2.05	V
		RD± {1:8}, SD± {1:8}	100BASE-FX	1.60	1.80	V
T _A	Ambient operating temperature	–	–	0	70	°C

Table 59: Electrical Characteristics

Symbol	Parameter	Pins	Conditions	Min	Typ	Max	Units
I _{DD}	Total supply current	AVDD, DVDD	100BASE-TX	–	839	892	mA
		OVDD	100BASE-TX	–	59	76	mA
V _{OH}	High-level output voltage	Digital outputs	I _{OH} = –12 mA, OVDD = 3.3 V	OVDD – 0.5	–	–	V
		Digital outputs	I _{OH} = –12 mA, OVDD = 2.5 V	OVDD – 0.4	–	–	V
		TD± {1:8}	Driving loaded magnetics module	–	–	VDD + 1.5	V
V _{OL}	Low-level output voltage	All digital outputs	I _{OL} = 8 mA	–	–	0.4	V
		TD± {1:8}	Driving loaded magnetics module	DVDD – 1.5	–	–	V
V _{ODIFF}	Differential output voltage	TD± {1:8}	100BASE-FX mode	400	–	–	mV

Table 59: Electrical Characteristics (Cont.)

Symbol	Parameter	Pins	Conditions	Min	Typ	Max	Units
I _I	Input current	Digital inputs with pull-up resistors	V _I = OVDD	–	–	+100	μA
			V _I = DGND	–	–	-200	μA
		Digital inputs with pull-down resistors	V _I = OVDD	–	–	+200	μA
			V _I = DGND	–	–	-100	μA
All other digital inputs	DGND ≤ V _I ≤ OVDD	–	–	±100	μA		
I _{OZ}	High-impedance output current	All three-state outputs	DGND ≤ V _O ≤ OVDD	–	–	–	μA
		All open-drain outputs	V _O = OVDD	–	–	–	μA
V _{bias}	Bias voltage	VREF, RDAC	–	1.18	–	1.30	V



Section 9: Mechanical Information

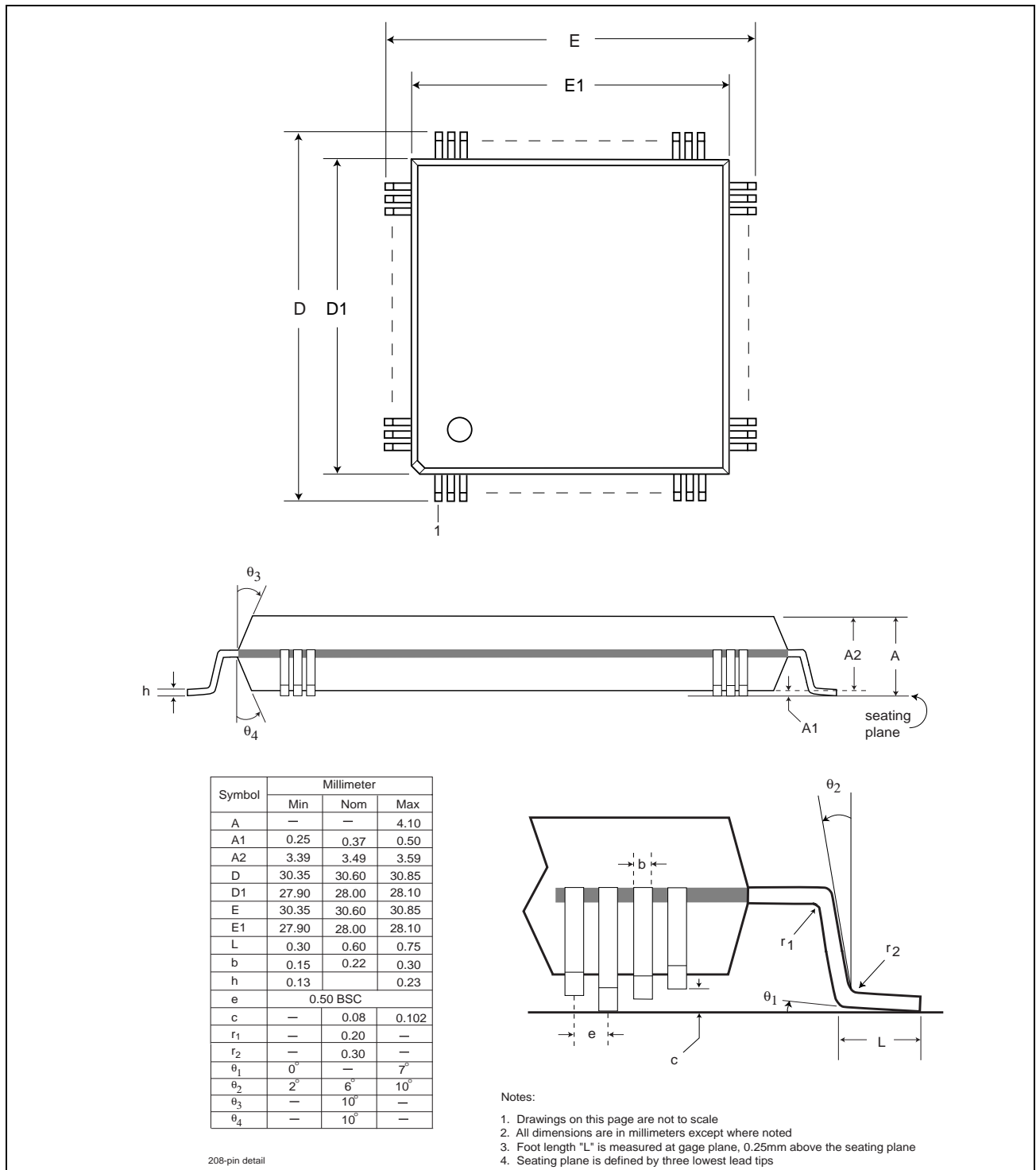

Figure 12: 208-Pin PQFP Package

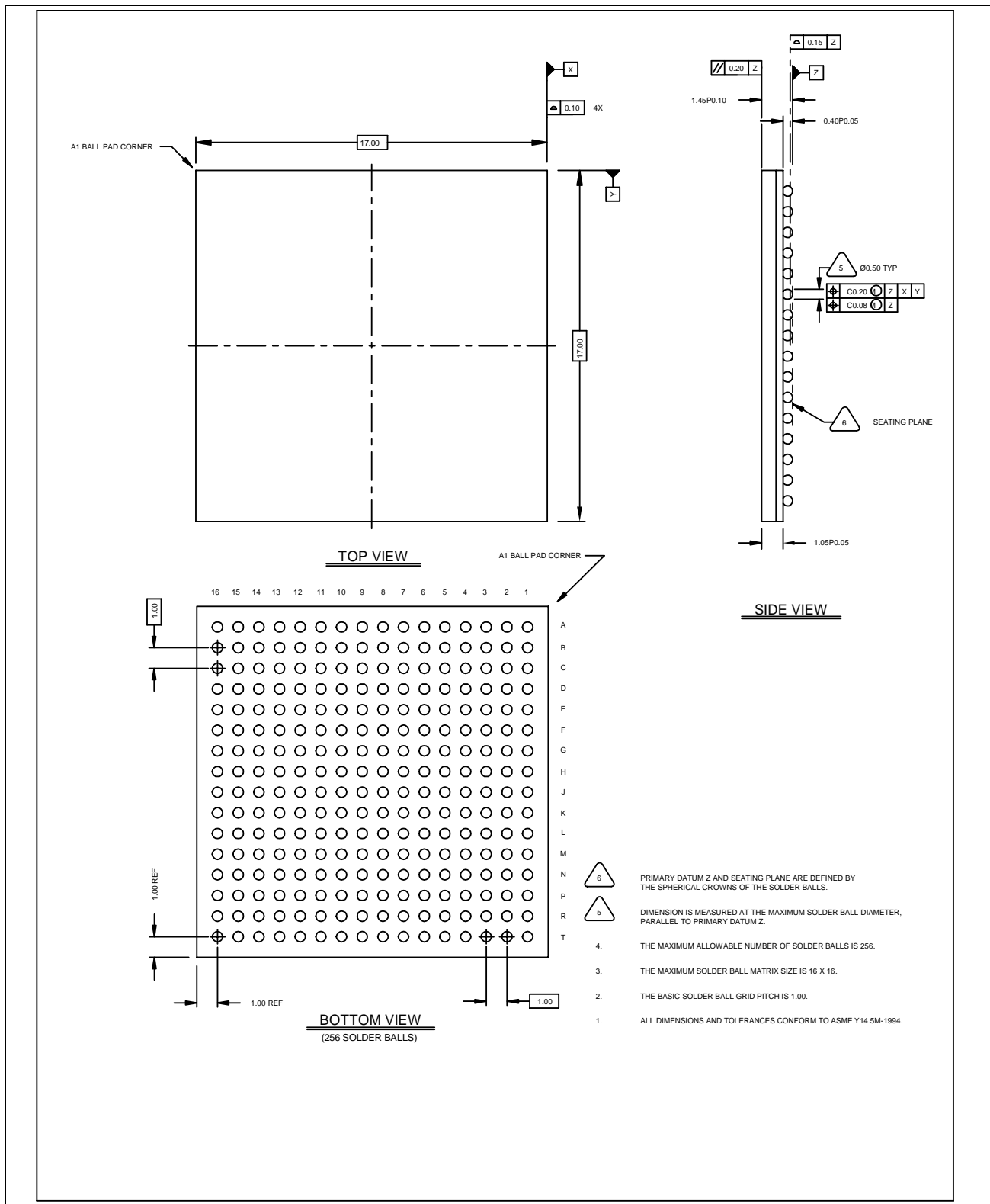

Figure 13: 256-Pin Fine Pitch BGA (FPBGA) Package



Section 10: Packaging Thermal Characteristics

Table 60: θ_{JA} vs. Airflow for the BCM5228B (256 FPBGA) Package

Airflow (feet per minute)	0	100	200	400	600
θ_{JA} (°C/W)	19.02	16.70	15.85	14.84	14.16

θ_{JC} for this package is 5.84°C/W. The BCM5228B is designed and rated for a maximum junction temperature of 125°C.

Table 61: θ_{JA} vs. Airflow for the BCM5228F (208 PQFP) Package

Airflow (feet per minute)	0	100	200	400	600
θ_{JA} (°C/W)	16.35	13.96	13.09	12.21	11.70

θ_{JC} for this package is 6.19°C/W. The BCM5228F is designed and rated for a maximum junction temperature of 125°C.

Table 62: θ_{JA} vs. Airflow for the BCM5228U (208 PQFP) Package

Airflow (feet per minute)	0	100	200	400	600
θ_{JA} (°C/W)	16.35	13.96	13.09	12.21	11.70

θ_{JC} for this package is 6.19°C/W. The BCM5228U is designed and rated for a maximum junction temperature of 125°C.



Section 11: Application Examples

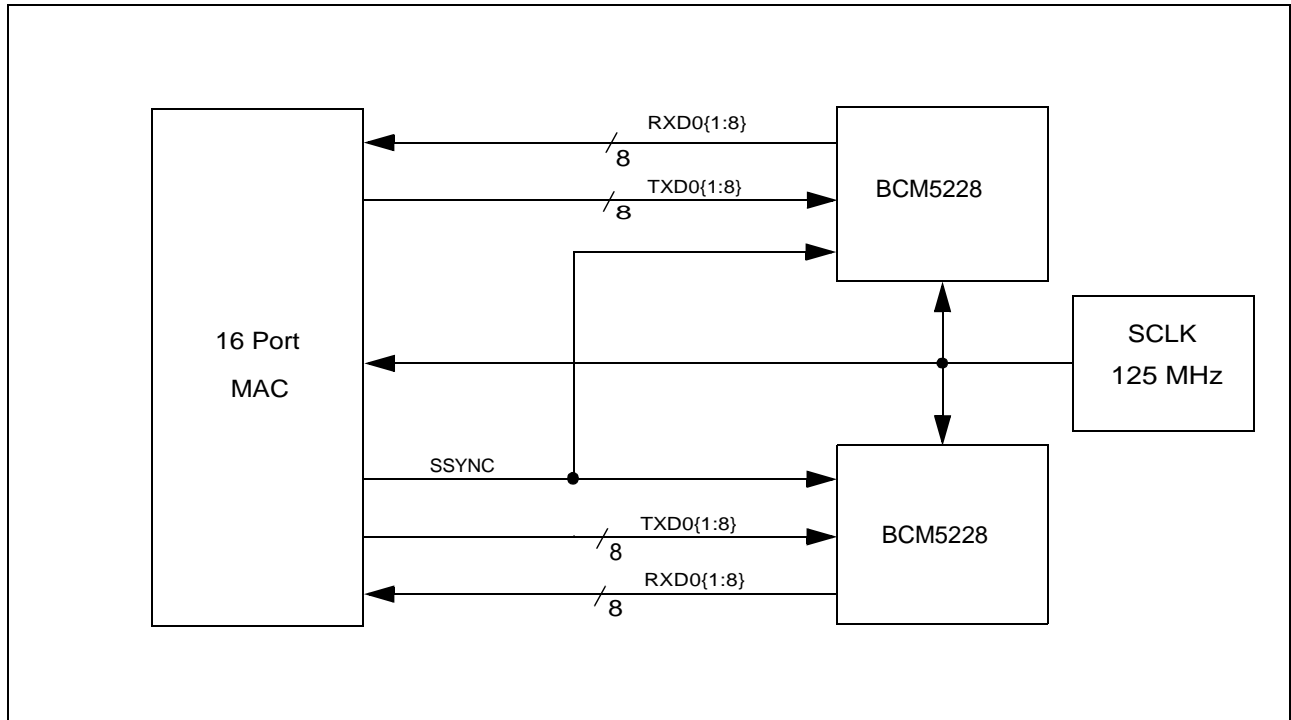

Figure 14: SMI Application

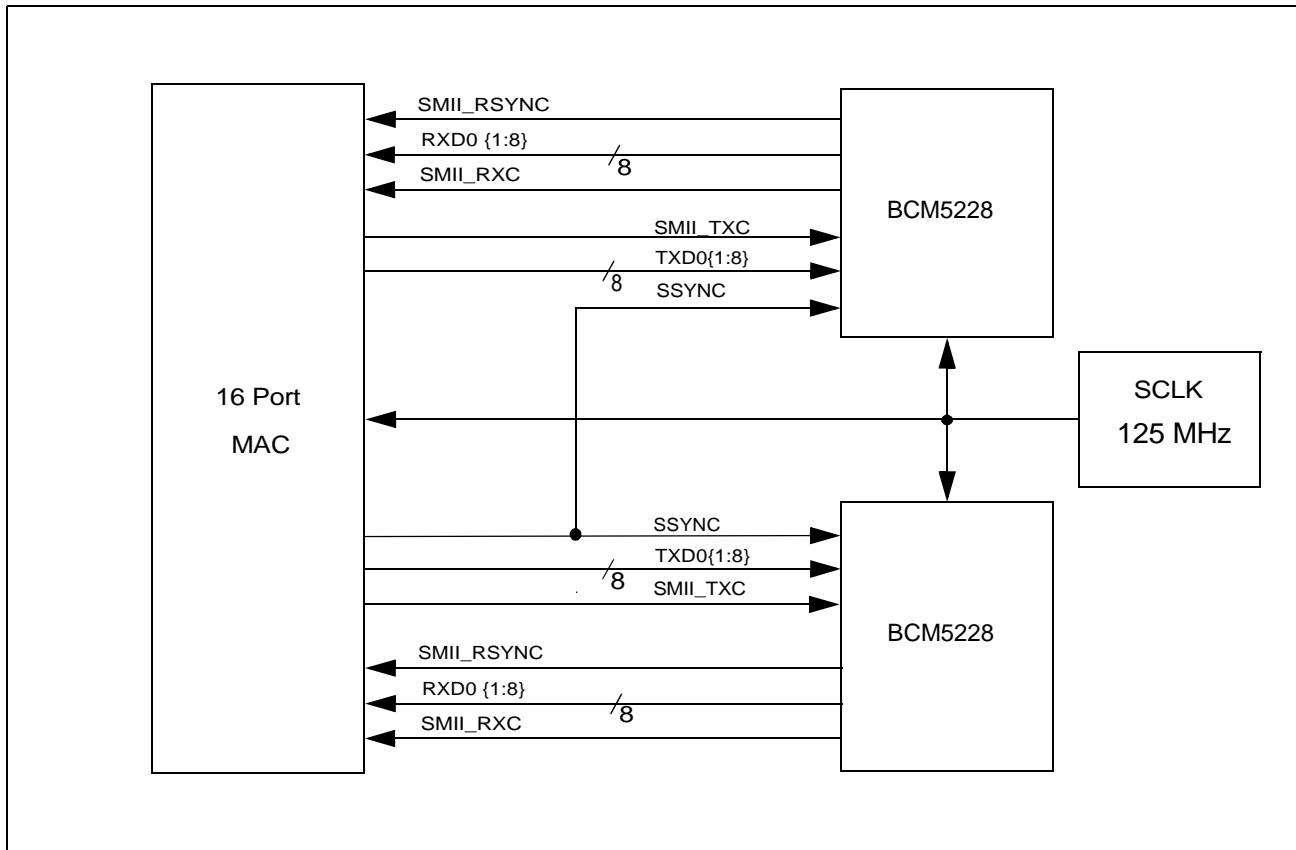

Figure 15: SMI Application using Source Synchronous Signals

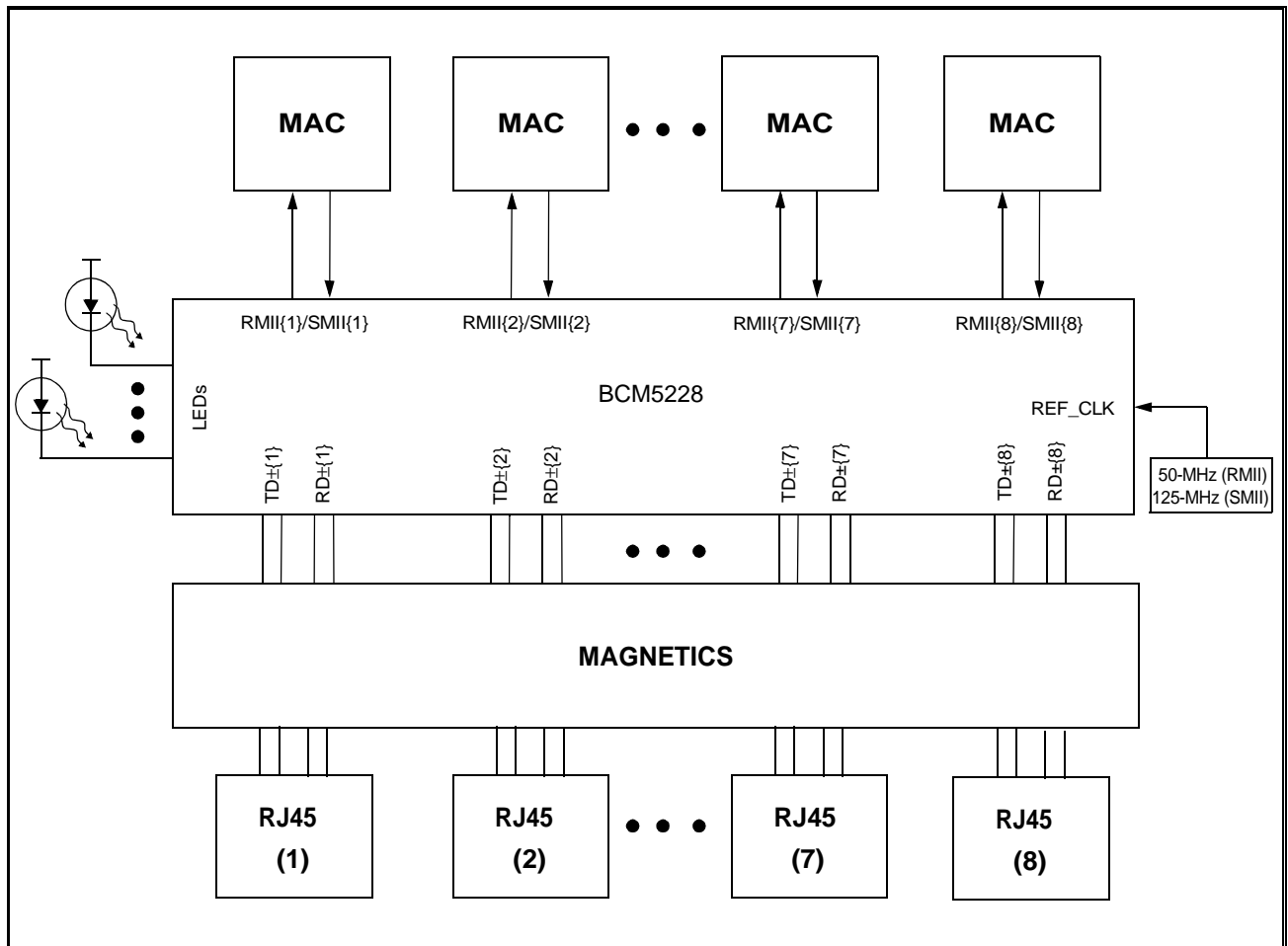

Figure 16: Switch Application



Section 12: Ordering Information

<i>Part Number</i>	<i>Package</i>	<i>Ambient Temperature</i>
BCM5228UA4KPF	208 PQFP	0°C to 70°C (32°F to 158° F)
BCM5228FA4KPF	208 PQFP	0°C to 70°C (32°F to 158°F)
BCM5228BA4KPB	256 FBGA	0°C to 70°C (32° F to 158°F)
BCM5228UA4IPF	208 PQFP	-40°C to 85°C (-40°F to 185°F)
BCM5228FA4IPF	208 PQFP	-40°C to 85°C (-40°F to 185°F)
BCM5228BA4IPB	256 FPBGA	-40°C to 70°C (-40°F to 158°F)

Note: A4 is the current revision number at the time of publication of this data sheet.

The BCM5228BA4IPB can operate at -40°C to +85°C (-40°F to 185°F) if used with a heat sink (see the following for details) or equivalent:

Manufacturer: Wakefield Engineering
Part Number: 624-60AB, made of extruded aluminum, 21 mm x 21 mm x 15.2 mm pin-fin
Thermal Interface: Chomerics T410 double-sided thermal tape

The following thermal data applies to the BCM5228BA4IPB with the heat sink previously described.

Table 63: θ_{JA} vs. Airflow for the BCM5228B with Heat Sink

Airflow (feet per minute)	0	100	200	400	600
θ_{JA} (°C/W)	13.37	11.51	10.61	9.94	9.58

Broadcom Corporation

16215 Alton Parkway
P.O. Box 57013
Irvine, CA 92619-7013
Phone: 949-450-8700
Fax: 949-450-8710

Broadcom[®] Corporation reserves the right to make changes without further notice to any products or data herein to improve reliability, function, or design. Information furnished by Broadcom Corporation is believed to be accurate and reliable. However, Broadcom Corporation does not assume any liability arising out of the application or use of this information, nor the application or use of any product or circuit described herein, neither does it convey any license under its patent rights nor the rights of others.