

RECOMMENDED PANEL CUTOUT
EMPFOHLENER FRONTPLATTEN AUSSCHNITT

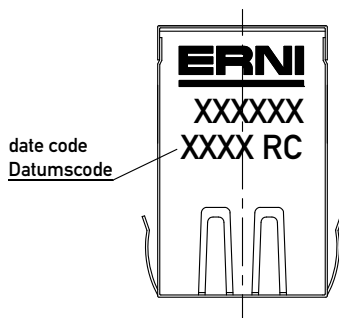
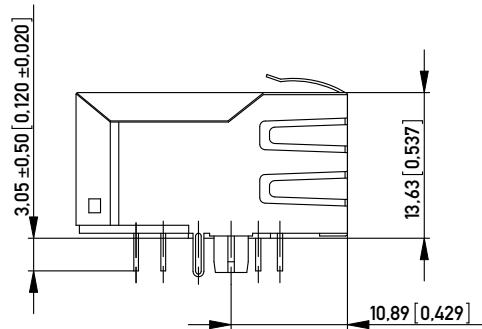
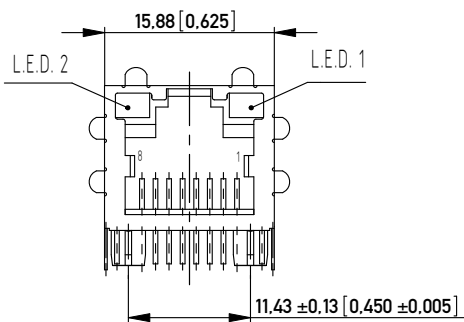
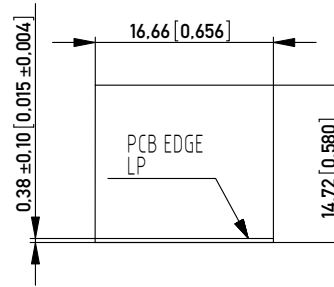

NO. IDENT. NR.	LED 2 LEFT LED 2 LINKS	LED 1 RIGHT LED 1 RECHTS	LED CODE
203348	YELLOW	GREEN	L1
203349	GREEN	YELLOW	L2
203350	GREEN	GREEN	L3
203351	GREEN	RED	L4
203352	ORANGE/GREEN	ORANGE/GREEN	L9

MATERIALS AND FINISH

HOUSING: GLASS FILLED POLYESTER UL 94 V-0 BLACK
 SHIELDING: Cu ALLOY, PLATED WITH Ni
 CONTACTS: PHOSPHOR BRONZE
 CONTACT FINISH: Au, 0.8 µm (30 µin), OVER Ni
 TERMINAL FINISH: Sn MATTE (A)
 LED LENS: EPOXY
 MECHANICAL CHARACTERISTICS
 DURABILITY: 1000 MATING CYCLES
 OPERATING TEMPERATURE: 0°C TO 70°C

Information: SCHEMATIC NUMBER MSB01		Tolerances All Dimensions in mm	Scale 2:1
All rights reserved. Only for information. To insure that this is the latest version of this drawing, please contact one of the ERNI companies before using.		Subject to modification without prior notice. Drawing will not be updated.	Designation MOD JACK -MJIMR 8C10T, 1x1, INT. MAG., LED. REVERSE LATCH
A	09.06.2008	www.ERNI.com	203347
Index	Date	Class	MJIM

RECOMMENDED PCB LAYOUT (COMPONENT SIDE VIEW)
 EMPFOHLENES LEITERPLATTEN-LAYOUT (BESTÜCKUNGSSEITE)
 TOL ±0.05 [0.002] UNLESS NOTED

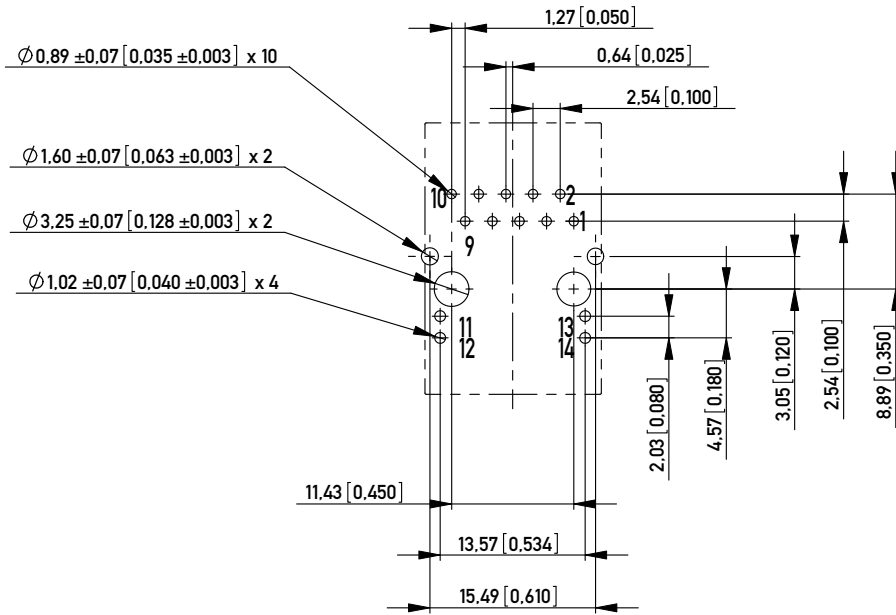

ELECTRICAL SCHEMATICS 1000 BASE T - M5B01
 ELEKTRISCHER SCHALTPLAN

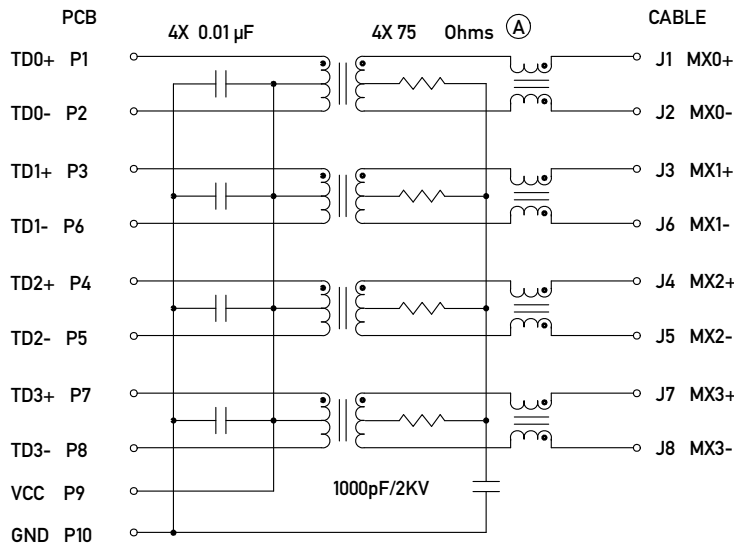

LED SPECIFICATIONS
 LED ANWEISUNG

COLOR FARBE	V _f TYP	V _f MAX	I _f mA	CIRCUIT DIAGRAM SCHALTPLAN
YELLOW	2.1	2.5	20	
GREEN	2.2	2.5	20	
RED	2.25	2.5	20	
ORANGE/GREEN	2.05/2.2	2.5	20	

MAGNETICS SPECIFICATIONS @ 25°C

TURNS RATIO: 1CT:1CT ±3%
 OCL(100 KHz, 0.1 V, 8 mA) 350 µH MIN
 INSERTION LOSS:
 1-100 MHz -1.1 dB MAX
 RETURN LOSS:
 1-40 MHz -18 dB MIN
 60 MHz -14 dB MIN
 80 MHz -12 dB MIN
 100 MHz -10 dB MIN
 CROSSTALK:
 1-100 MHz -35 dB TYP
 CMR:
 0.1 - 30 MHz -50 dB TYP
 30 - 60 MHz -40 dB TYP
 60 - 100 MHz -35 dB TYP
 ISOLATION 1500 Vrms

Information:	Tolerances		Scale 2:1
All rights reserved. Only for information. To insure that this is the latest version of this drawing, please contact one of the ERNI companies before using.	Subject to modification without prior notice. Drawing will not be updated.	All Dimensions in mm	Designation
			MOD JACK -MJIMR 8C10T, 1x1, INT. MAG., LED. REVERSE LATCH
www.ERNI.com	Class MJIM	203347	I (2/2)
			A3

Consider protection films from DIN 54