

TLE4921-5U

Dynamic Differential Hall Effect Sensor IC Detection

About this document

Overview

Features

- Advanced performance
- High sensitivity
- Symmetrical thresholds
- High piezo resistivity
- Reduced power consumption
- South and north pole pre-induction possible
- AC coupled
- Digital output signal
- Two-wire and three-wire configuration possible
- Large temperature range
- Large airgap
- Low cut-off frequency
- Protection against overvoltage
- Protection against reversed polarity
- Output protection against electrical disturbances

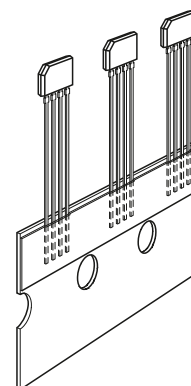

Target applications

The differential Hall Effect sensor TLE4921-5U provides a high sensitivity and a superior stability over temperature and symmetrical thresholds in order to achieve a stable duty cycle. TLE4921-5U is particularly suitable for rotational speed detection and timing applications of ferromagnetic toothed wheels such as anti-lock braking systems, transmissions, crankshafts, etc. The integrated circuit (based on Hall effect) provides a digital signal output with frequency proportional to the speed of rotation. Unlike other rotational sensors differential Hall ICs are not influenced by radial vibration within the effective airgap of the sensor and require no external signal processing.

| Product type | Marking | Ordering code | Package |
|--------------|---------|---------------|------------|
| TLE4921-5U | 215U | SP000013593 | PG-SSO-4-1 |

Table of contents

| | | |
|----------|---|----|
| | About this document | 1 |
| | Table of contents | 2 |
| 1 | General | 3 |
| 1.1 | Pin Configuration (view on branded side of component) | 3 |
| 1.2 | Block diagram | 3 |
| 1.3 | Functional description | 4 |
| 1.4 | Circuit description | 4 |
| 2 | Maximum ratings | 5 |
| 3 | Operating range | 6 |
| 4 | Electrical and magnetic parameters | 7 |
| 5 | Application configurations | 9 |
| 6 | Typical performance characteristics | 12 |
| 7 | Package outlines | 19 |
| 8 | Revision history | 20 |
| | Disclaimer | 21 |

1 General

1 General

1.1 Pin Configuration (view on branded side of component)

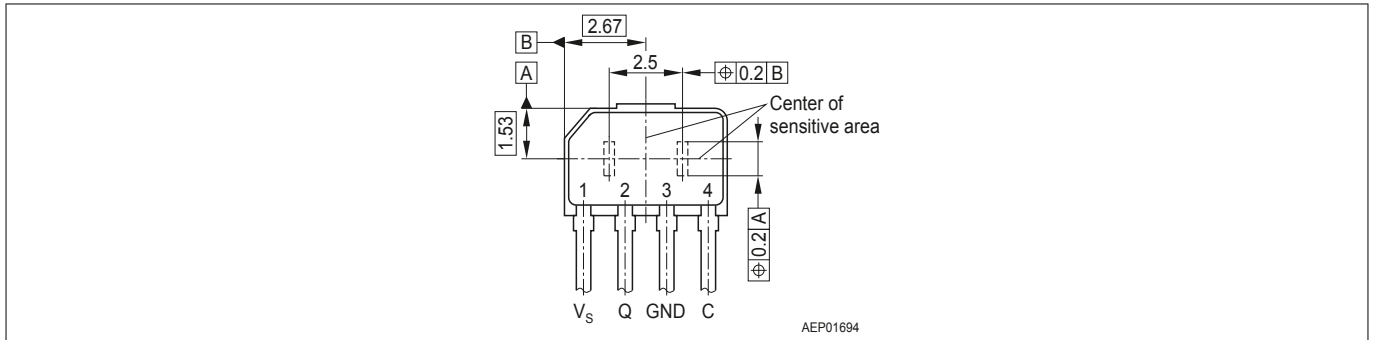

Figure 1

Table 1 Pin definitions and functions

| Pin No. | Symbol | Function |
|---------|--------|----------------|
| 1 | V_S | Supply voltage |
| 2 | Q | Output |
| 3 | GND | Ground |
| 4 | C | Capacitor |

1.2 Block diagram

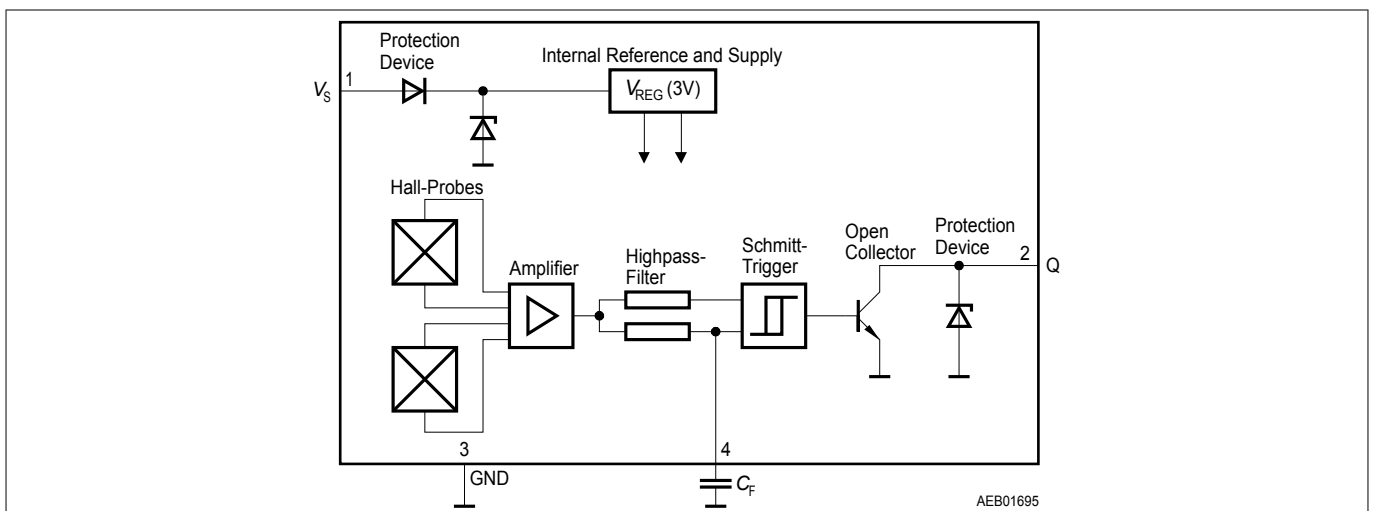

Figure 2 Block diagram

1 General

1.3 Functional description

The Differential Hall Sensor IC detects the motion and position of ferromagnetic and permanent magnet structures by measuring the differential flux density of the magnetic field. To detect ferromagnetic objects the magnetic field must be provided by a back biasing permanent magnet (south or north pole of the magnet attached to the rear unmarked side of the IC package).

Using an external capacitor the generated Hall voltage signal is slowly adjusted via an active high pass filter with a low cut-off frequency. This causes the output to switch into a biased mode after a time constant is elapsed. The time constant is determined by the external capacitor. Filtering avoids ageing and temperature influence from Schmitttrigger input and eliminates device and magnetic offset.

The TLE4921-5U can be exploited to detect toothed wheel rotation in a rough environment. Jolts against the toothed wheel and ripple have no influence on the output signal.

Furthermore, the TLE4921-5U can be operated in a two-wire as well as in a three-wire configuration.

The output is logic compatible by high/low levels regarding on and off.

1.4 Circuit description

The TLE4921-5U is comprised of a supply voltage reference, a pair of Hall probes spaced at 2.5 mm, differential amplifier, filter for offset compensation, Schmitt trigger, and an open collector output.

The TLE4921-5U was designed to have a wide range of application parameter variations. Differential fields up to ± 80 mT can be detected without influence to the switching performance. The pre-induction field can either come from a magnetic south or north pole, whereby the field strength up to 500 mT or more will not influence the switching points. The improved temperature compensation enables a superior sensitivity and accuracy over the temperature range. Finally the optimized piezo compensation and the integrated dynamic offset compensation enable easy manufacturing and elimination of magnet offsets.

Protection is provided at the input/supply (pin 1) for overvoltage and reverse polarity and against over-stress such as load dump, etc., in accordance with ISO-TR 7637 and DIN 40839. The output (pin 2) is protected against voltage peaks and electrical disturbances.

2 Maximum ratings

2 Maximum ratings

Table 2 Absolute maximum ratings

$T_j = -40^\circ\text{C}$ to 150°C

| Parameter | Symbol | Limit Values | | Unit | Remarks |
|--|------------|--------------|------|------|-----------------------|
| | | Min. | Max. | | |
| Supply voltage | V_S | $-35^{1)}$ | 30 | V | |
| Output voltage | V_Q | -0.7 | 30 | V | |
| Output current | I_Q | - | 50 | mA | |
| Output reverse current | $-I_Q$ | - | 50 | mA | |
| Capacitor voltage | V_C | -0.3 | 3 | V | |
| Junction temperature | T_j | - | 150 | °C | 5000 h |
| | | - | 160 | | 2500 h |
| | | - | 170 | | 1000 h |
| | | - | 210 | | 40 h |
| Storage temperature | T_S | -40 | 150 | °C | |
| Thermal resistance PG-SSO-4-1 | R_{thJA} | - | 190 | K/W | |
| Current through input-protection device | I_{SZ} | - | 200 | mA | $t < 2$ ms; $v = 0.1$ |
| Current through output-protection device | I_{QZ} | - | 200 | mA | $t < 2$ ms; $v = 0.1$ |

1) Reverse current < 10 mA

3 Operating range

3 Operating range

Table 3 ESD Protection

Human Body Model (HBM) tests according to: Standard EIA/JESD22-A114-B HBM

| Parameter | Symbol | Limit Values | | Unit | Remarks |
|------------------|-----------|--------------|---------|------|---------|
| | | Min. | Max. | | |
| ESD - protection | V_{ESD} | - | ± 2 | kV | |

Table 4 Operating range

| Parameter | Symbol | Limit Values | | | Unit | Remarks |
|------------------------|------------|--------------|------|------|------|---|
| | | Min. | Typ. | Max. | | |
| Supply voltage | V_S | 4.5 | - | 24 | V | |
| Junction temperature | T_j | -40 | - | 150 | °C | 5000 h |
| | | - | - | 160 | | 2500 h |
| | | - | - | 170 | | 1000 h |
| Pre-induction | B_0 | -500 | - | 500 | mT | at Hall probe; independent of magnet orientation |
| Differential induction | ΔB | -80 | - | 80 | mT | |

Note: In the operating range the functions given in the circuit description are fulfilled.

4 Electrical and magnetic parameters

4 Electrical and magnetic parameters

Table 5 Electrical Characteristics table template

| Parameter | Symbol | Limit Values | | | Unit | Test Condition | Test Circuit |
|---|---------------------|---------------|------|-------|---------------|---|----------------|
| | | Min. | Typ. | Max. | | | |
| Supply current | I_S | 3.8 | 5.3 | 8.0 | mA | $V_Q = \text{high}$ $I_Q = 0 \text{ mA}$ | 1 |
| | | 4.3 | 5.9 | 8.8 | mA | $V_Q = \text{low}$ $I_Q = 40 \text{ mA}$ | 1 |
| Output saturation voltage | V_{QSAT} | - | 0.25 | 0.6 | V | $I_Q = 40 \text{ mA}$ | 1 |
| Output leakage current | I_{QL} | - | - | 50 | μA | $V_Q = 24 \text{ V}$ | 1 |
| Center of switching points: $(\Delta B_{OP} + \Delta B_{RP}) / 2$ | ΔB_m | -1 | 0 | 1 | mT | $-20 \text{ mT} < \Delta B < 20 \text{ mT}$ ¹⁾²⁾ $f = 200 \text{ Hz}$ | 2 |
| Operate point | ΔB_{OP} | - | - | 0 | mT | $f = 200 \text{ Hz}$, $\Delta B = 20 \text{ mT}$ | 2 |
| Release point | ΔB_{RP} | 0 | - | - | mT | $f = 200 \text{ Hz}$, $\Delta B = 20 \text{ mT}$ | 2 |
| Hysteresis | ΔB_H | 0.5 | 1.5 | 2.5 | mT | $f = 200 \text{ Hz}$, $\Delta B = 20 \text{ mT}$ | 2 |
| Overvoltage protection at supply voltage at output | V_{SZ} | 27 | - | 35 | V | $I_S = 16 \text{ mA}$ | 1 |
| | V_{QZ} | 27 | - | 35 | V | $I_Q = 16 \text{ mA}$ | 1 |
| Output rise time | t_r | - | - | 0.5 | μs | $I_Q = 40 \text{ mA}$ $C_L = 10 \text{ pF}$ | 1 |
| Output fall time | t_f | - | - | 0.5 | μs | $I_Q = 40 \text{ mA}$ $C_L = 10 \text{ pF}$ | 1 |
| Delay time | t_{dop} | - | - | 25 | μs | $f = 10 \text{ kHz}$ $\Delta B = 5 \text{ mT}$ | 2 |
| | t_{drp} | - | - | 10 | μs | | |
| | $t_{dop} - t_{drp}$ | - | 0 | 15 | μs | | |
| Filter input resistance | R_C | 35 | 43 | 52 | k Ω | $25^\circ\text{C} \pm 2^\circ\text{C}$ | 1 |
| Filter sensitivity to ΔB | S_C | - | -5 | - | mV/ mT | - | 1 |
| Filter bias voltage | V_C | 1.6 | 2 | 2.4 | V | $\Delta B = 0$ | 1 |
| Frequency | f | ³⁾ | - | 20000 | Hz | $\Delta B = 5 \text{ mT}$ | 2 |
| Resistivity against mechanical stress (piezo) | ΔB_m | -0.1 | - | 0.1 | mT | $F = 2 \text{ N}$ | ²⁴⁾ |
| | ΔB_H | -0.1 | - | 0.1 | mT | | |

1) The Current consumption characteristic will be different and the specified values can slightly change

4 Electrical and magnetic parameters

- 2) Leakage currents at pin 4 should be avoided. The bias shift of B_m caused by a leakage current I_L can be calculated by:

$$\Delta B_m = \frac{I_L \times R_C(T)}{S_C(T)}$$

- 3) For higher ΔB the values may exceed the limits like following $|\Delta B_m| < |0.05 \times \Delta B|$
 4) Depends on filter capacitor C_F . The cut-off frequency is given by

$$f = \frac{1}{2\pi \times R_C \times C_F}$$

. The switching points are guaranteed over the whole frequency range, but amplitude modification and phase shift due to the 1st order highpass filter have to be taken into account.

Note: The listed characteristics are ensured over the operating range of the integrated circuit. Typical characteristics specify mean values expected over the production spread. If not otherwise specified, typical characteristics apply at $T_j = 25^\circ\text{C}$ and the given supply voltage.

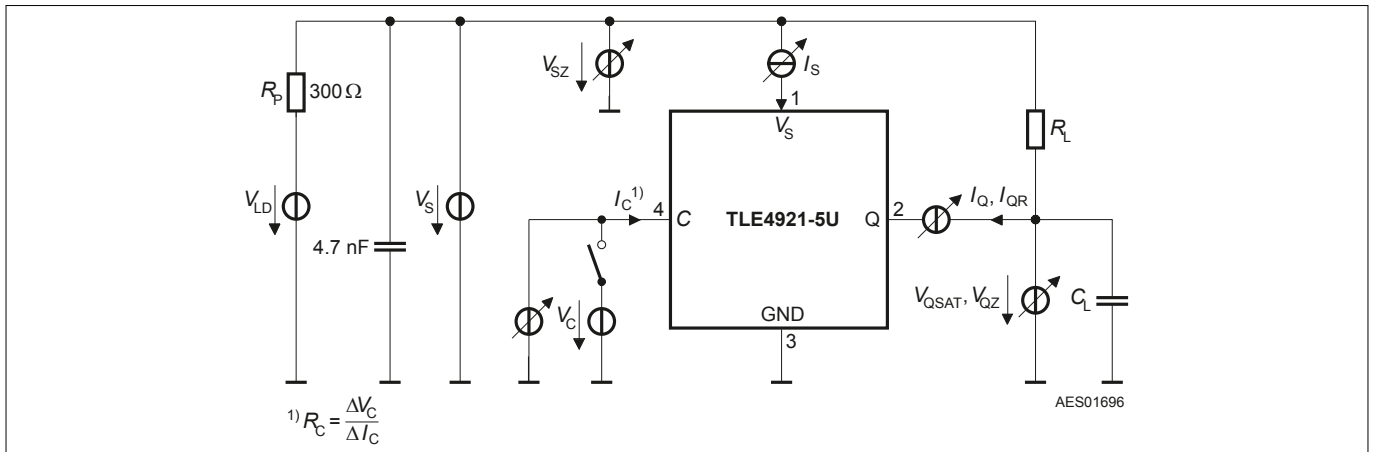

Figure 3 Test circuit 1

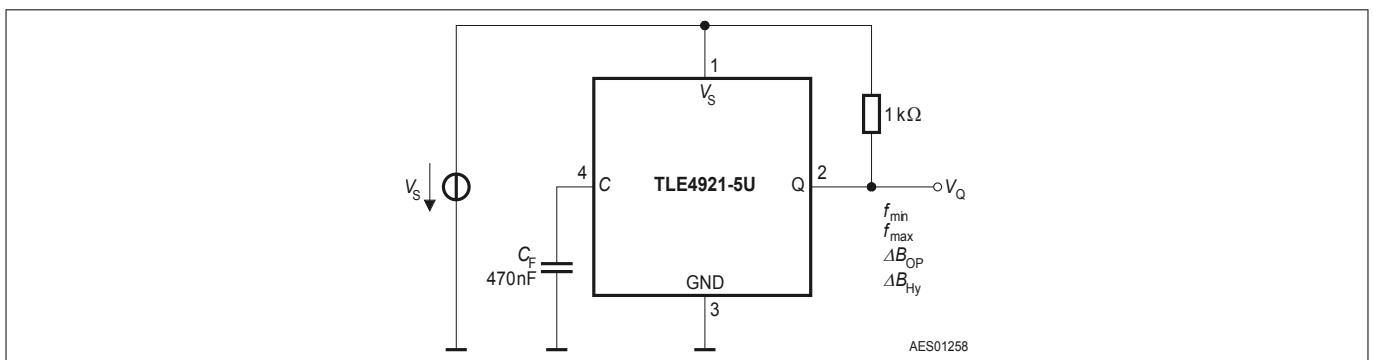

Figure 4 Test circuit 2

5 Application configurations

5 Application configurations

Two possible applications are shown in Figure 7 and Figure 8 (Toothed and Magnet Wheel). The difference between two-wire and three-wire application is shown in Figure 9.

Gear Tooth Sensing

In the case of ferromagnetic toothed wheel application the IC has to be biased by the south or north pole of a permanent magnet (e.g. SmCO₅ (Vacuumschmelze VX145)) with the dimensions 8 mm × 5 mm × 3 mm) which should cover both Hall probes.

The maximum air gap depends on:

- the magnetic field strength (magnet used; pre-induction) and
- the toothed wheel that is used (dimensions, material, etc.; resulting differential field)

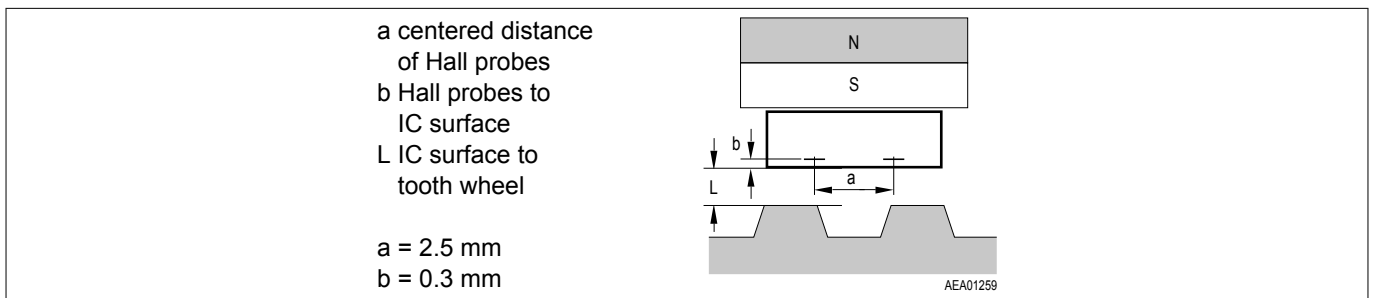

Figure 5 Sensor Spacing

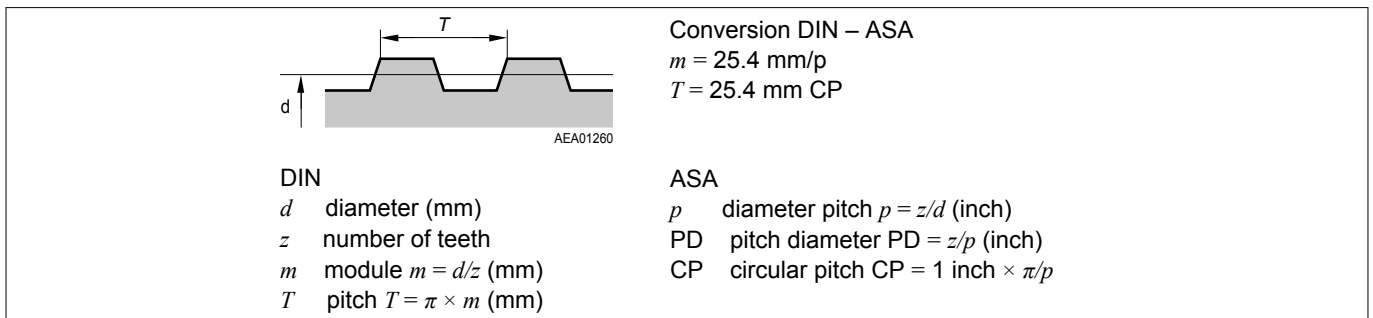

Figure 6 Tooth Wheel Dimensions

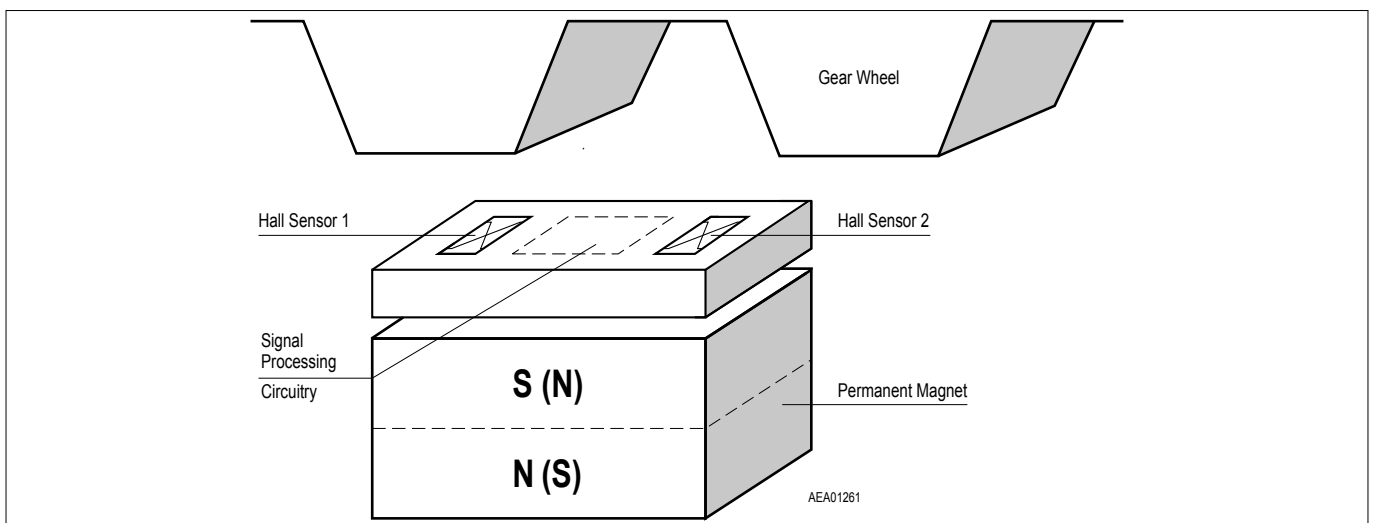

Figure 7 TLE4921-5U, with Ferromagnetic Toothed Wheel

5 Application configurations

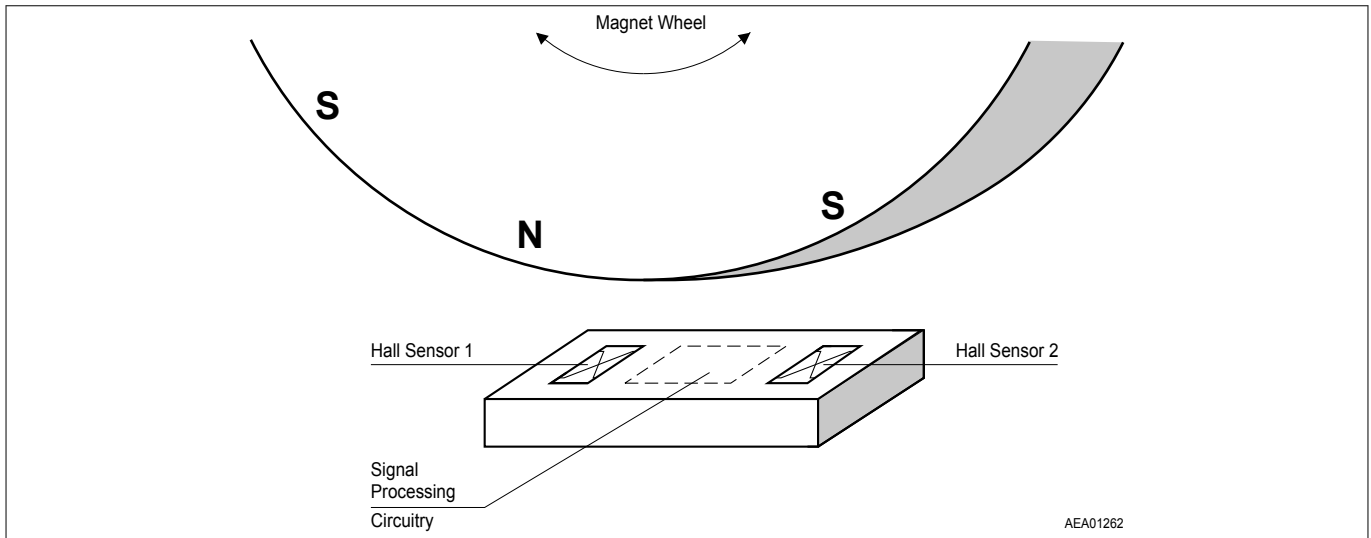

Figure 8 **TLE4921-5U, with Magnet Wheel**

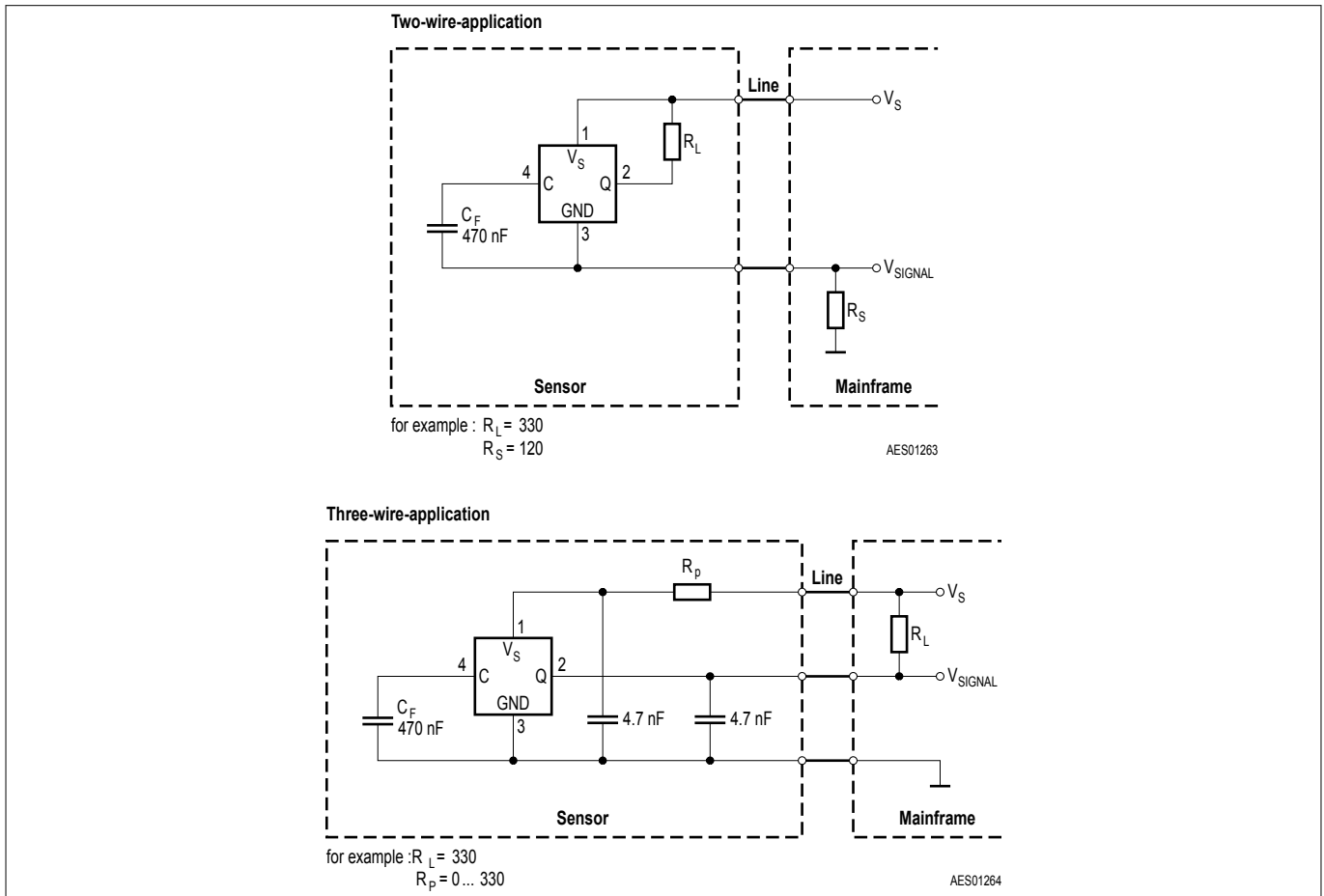

Figure 9 **Application Circuits**

5 Application configurations

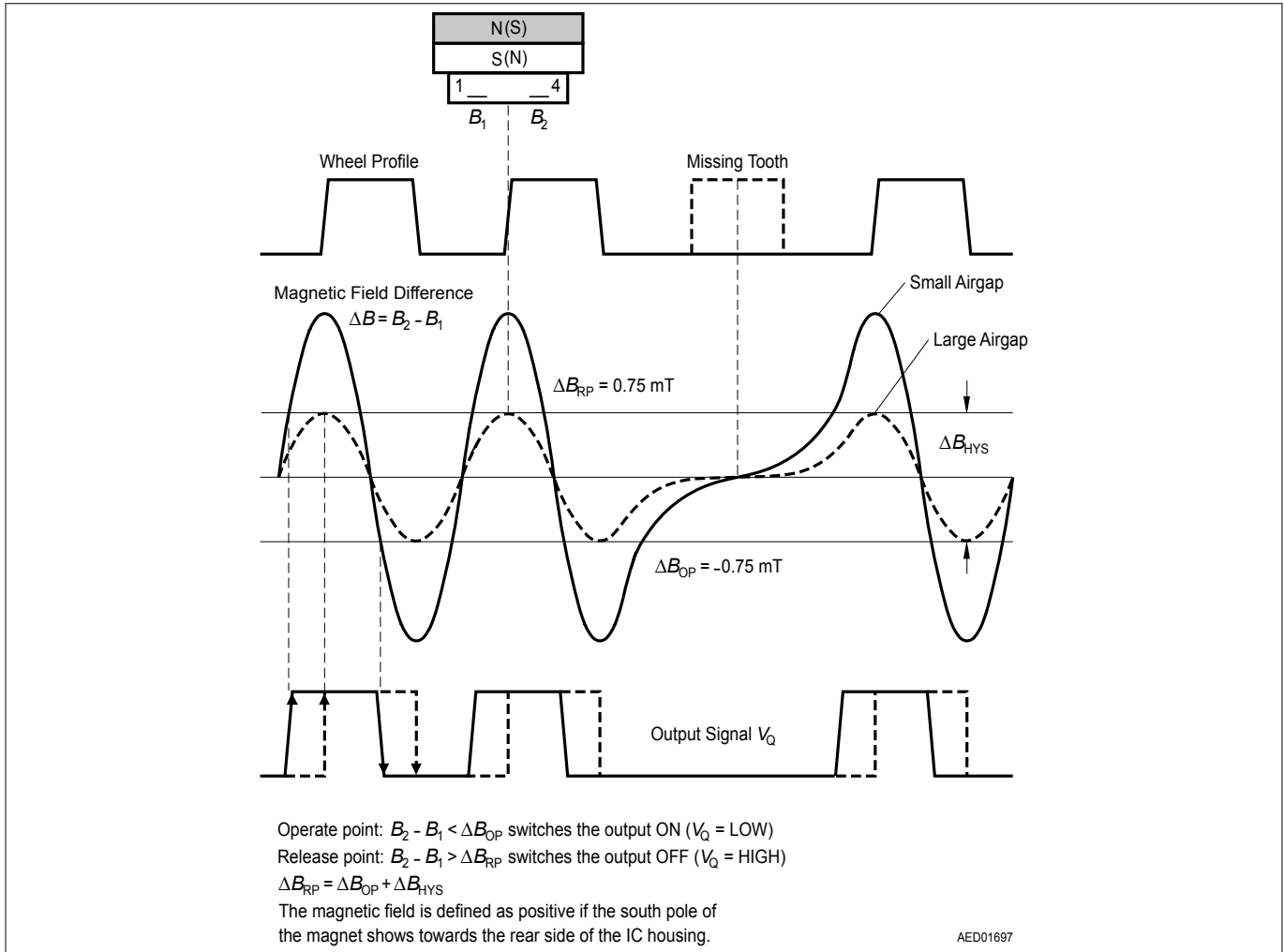
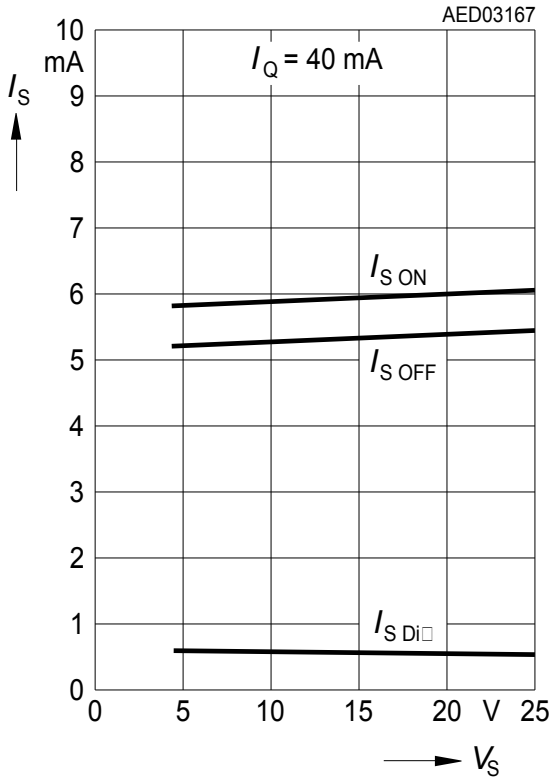

Figure 10 **System Operation**

6 Typical performance characteristics

6 Typical performance characteristics

Quiescent Current versus Supply Voltage



Quiescent Current versus Temperature

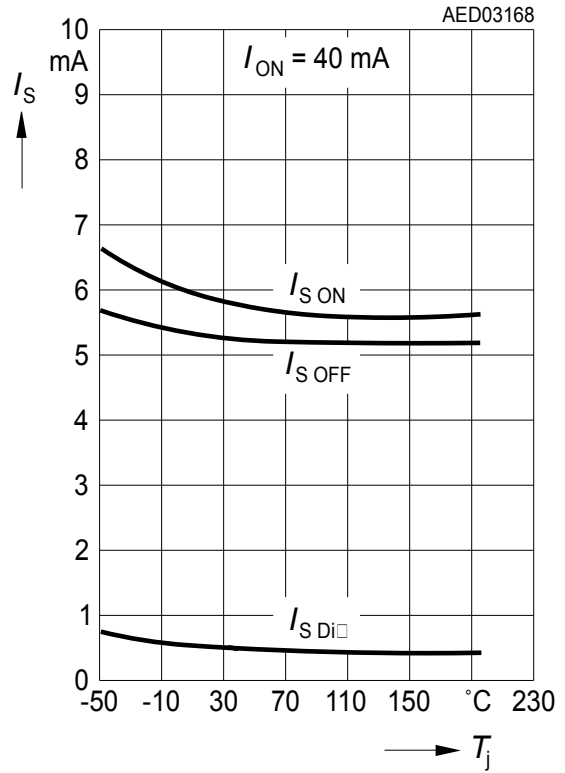

Quiescent Current versus Output Current

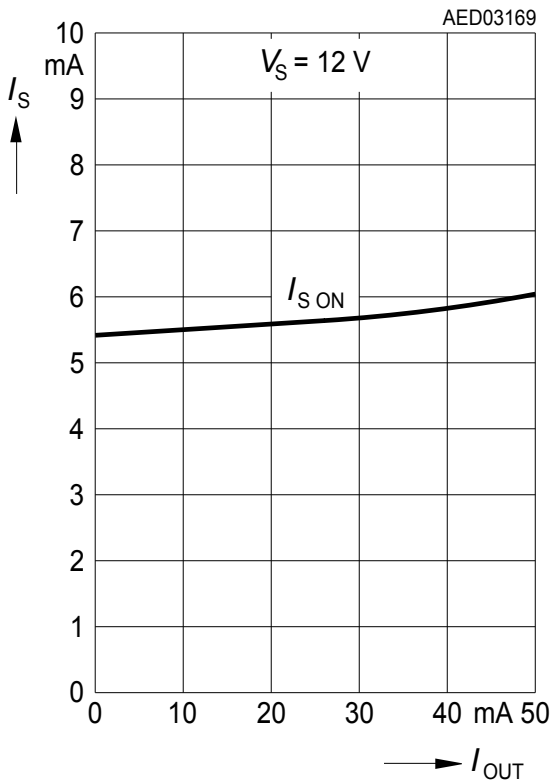

Saturation Voltage versus Temperature

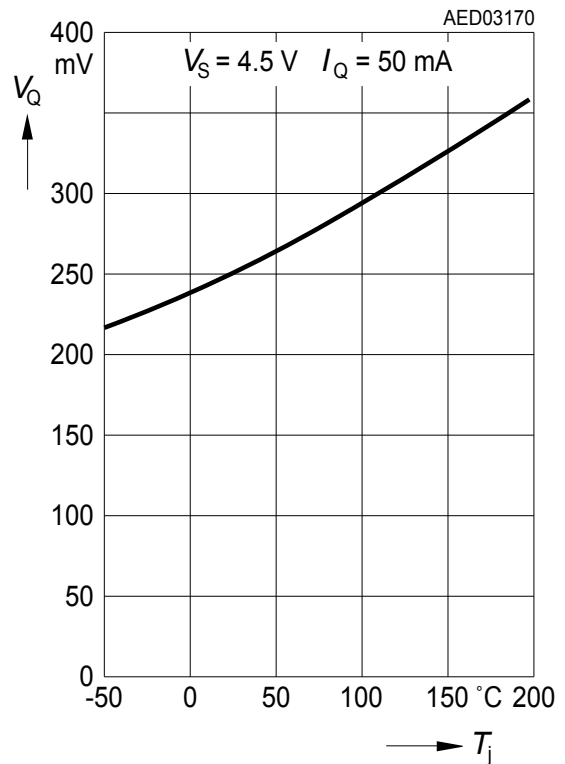

6 Typical performance characteristics

Output Saturation Voltage versus I_Q @ 25°C T_j

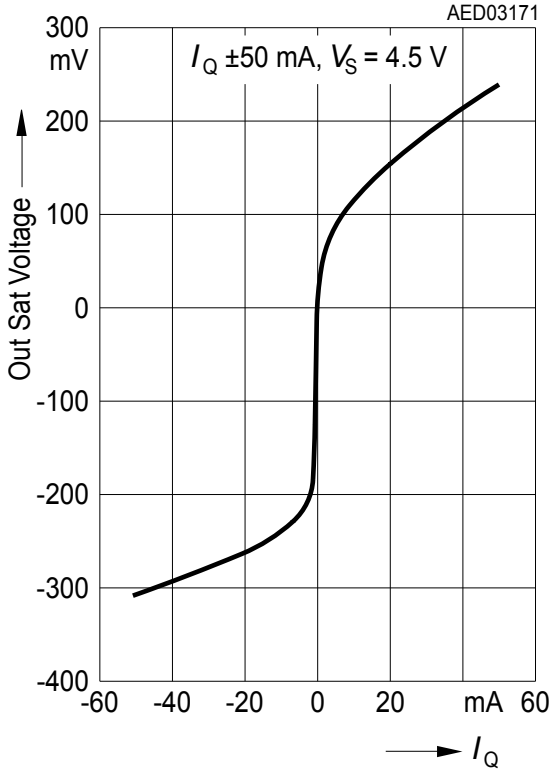

Saturation Voltage versus Supply Voltage

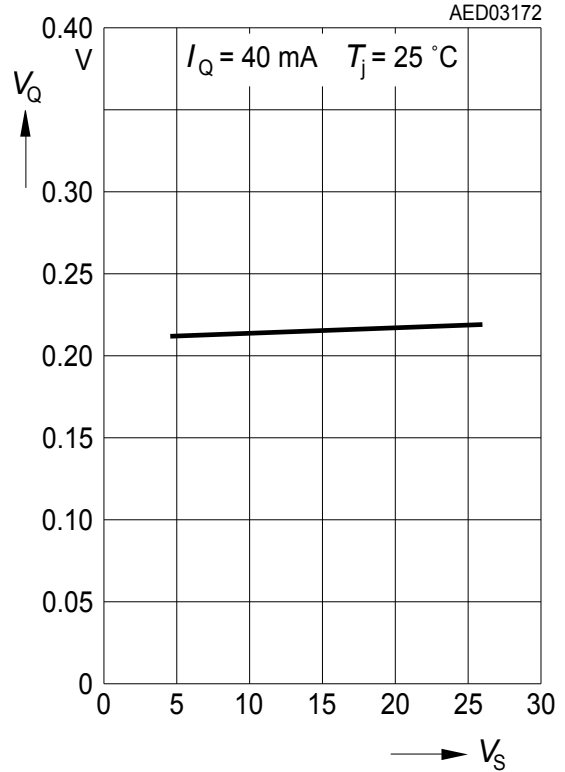

Center of Switching Points versus Temperature

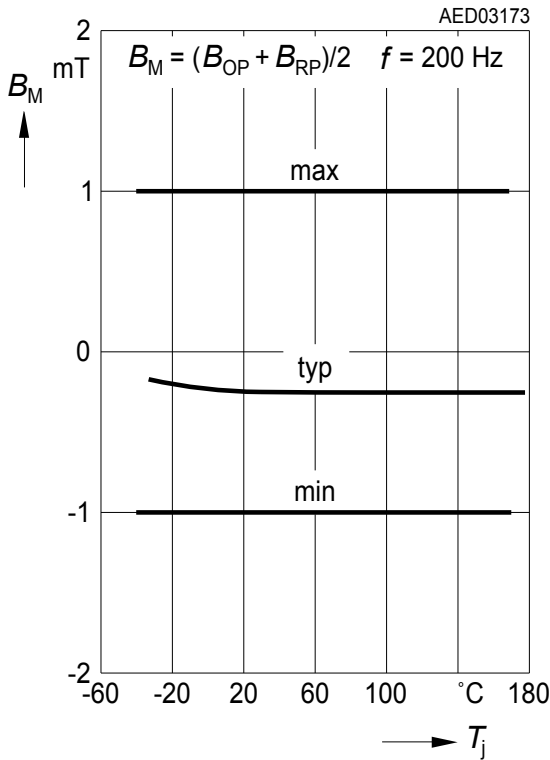

Hysteresis versus Temperature

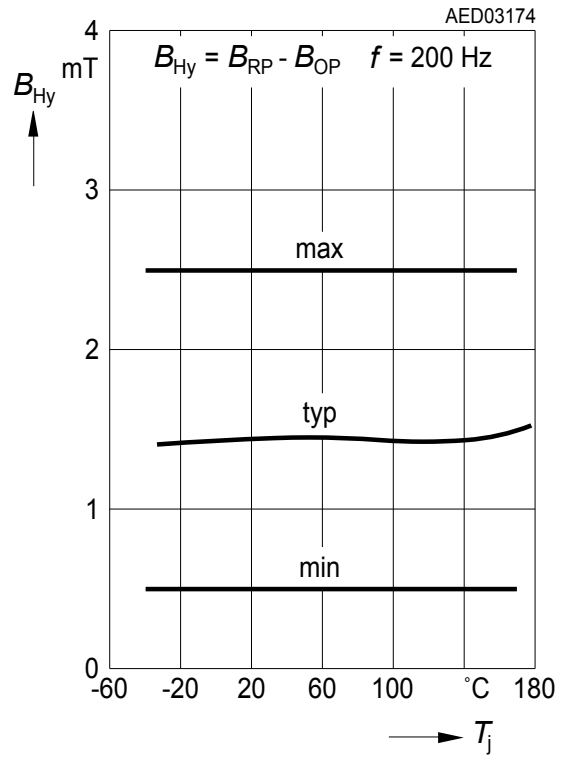

6 Typical performance characteristics

Minimum Switching Field versus Frequency

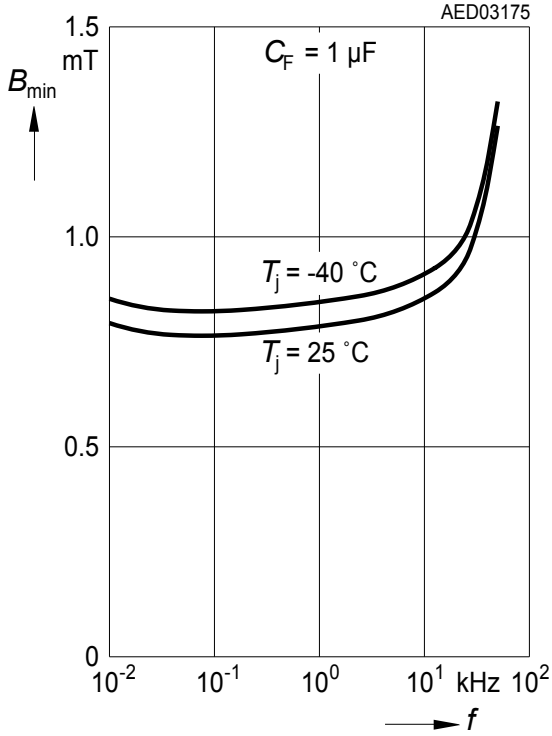

Minimum Switching Field versus Frequency

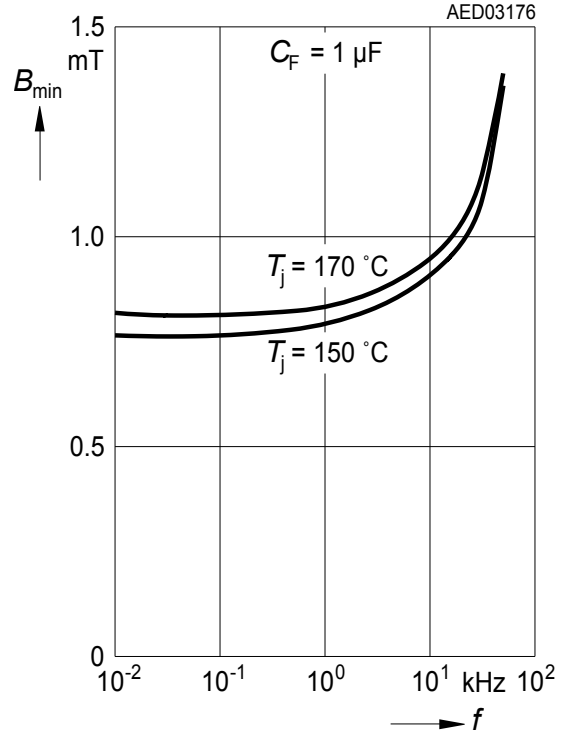

Delay Time between Switching Threshold ΔB and Falling Edge of V_{OUT} at $T_j = 25^\circ C$

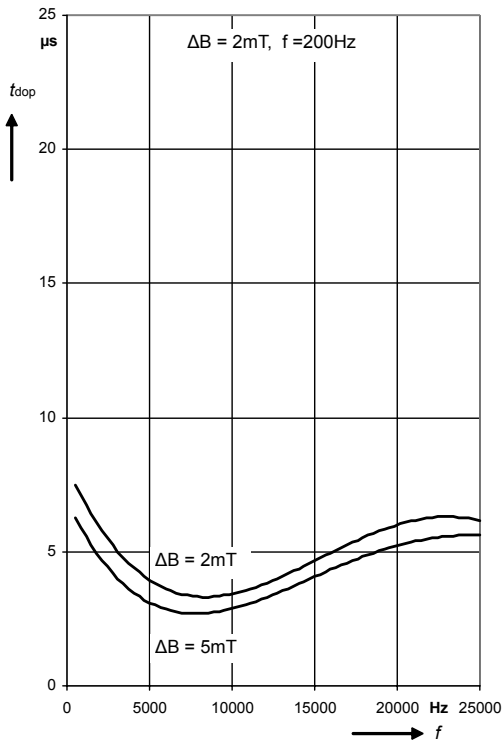

Delay Time between Switching Threshold ΔB and Rising Edge of V_{OUT} at $T_j = 25^\circ C$

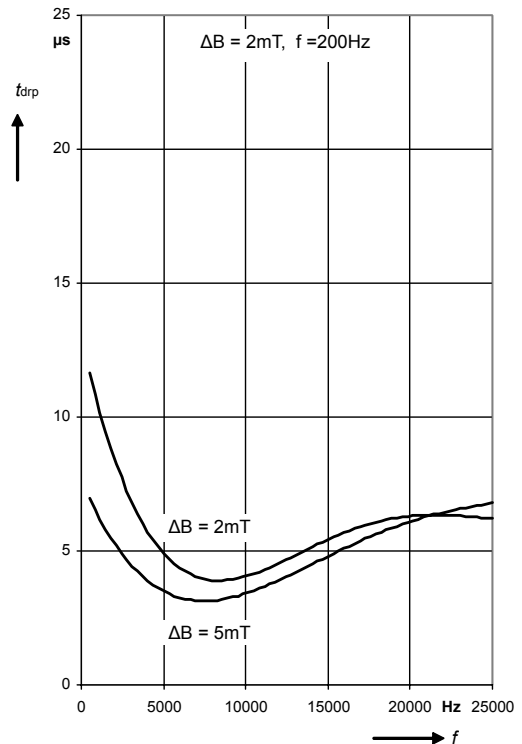

6 Typical performance characteristics

Delay Time versus Differential Field

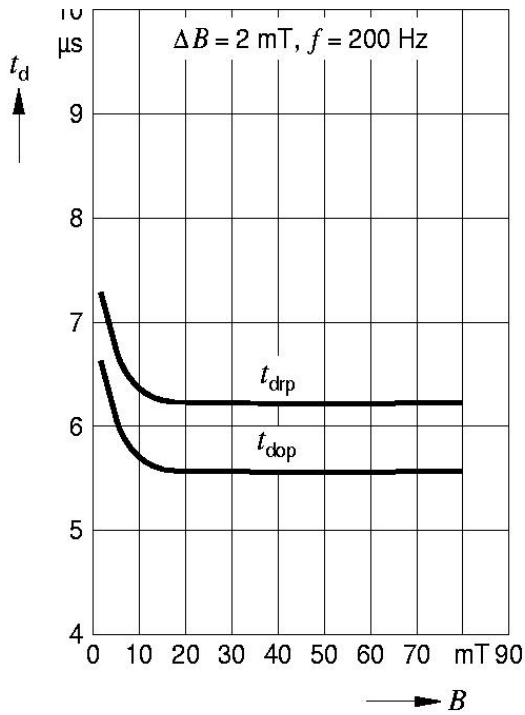

Delay Time versus Temperature

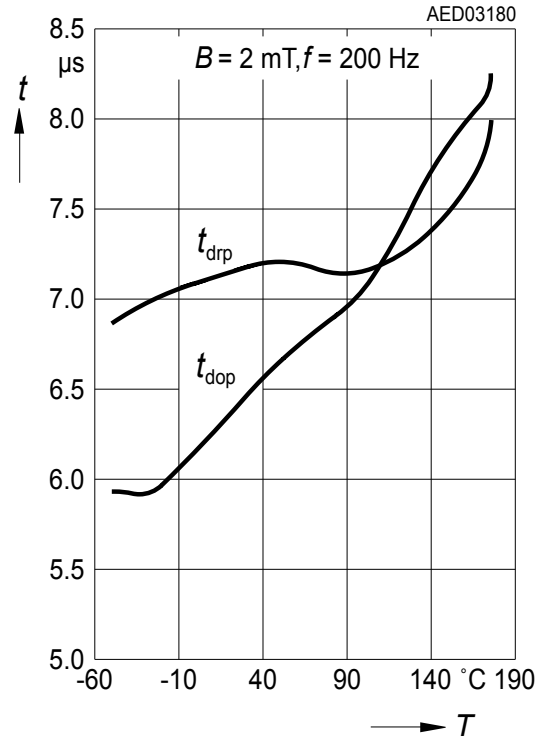

Rise and Fall Time versus Temperature

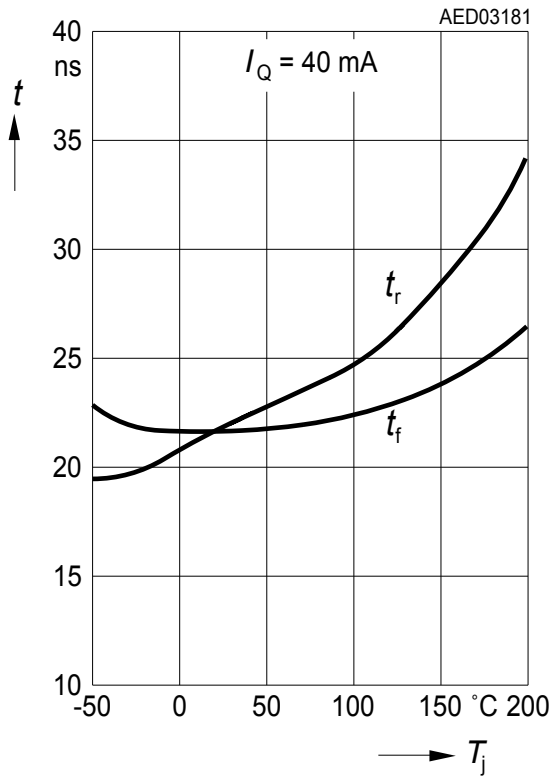

Rise and Fall Time versus Output Current

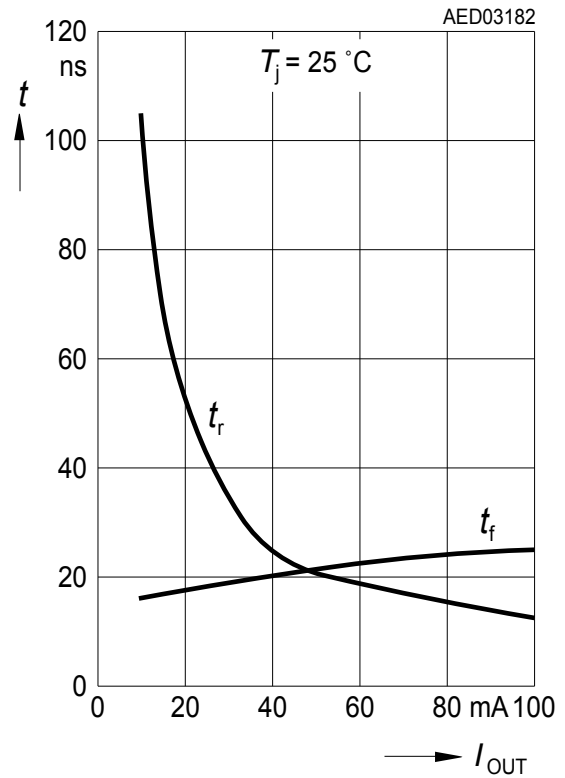

6 Typical performance characteristics

Capacitor Voltage versus Temperature

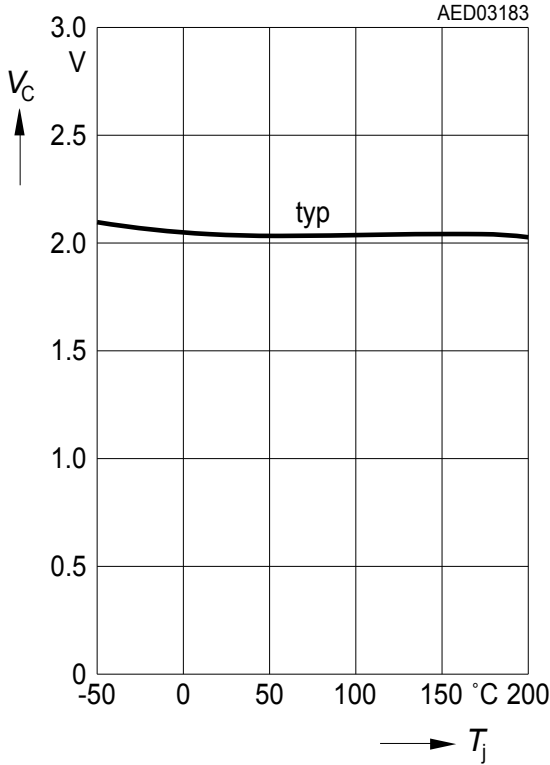

Switching Thresholds versus Mechanical Stress

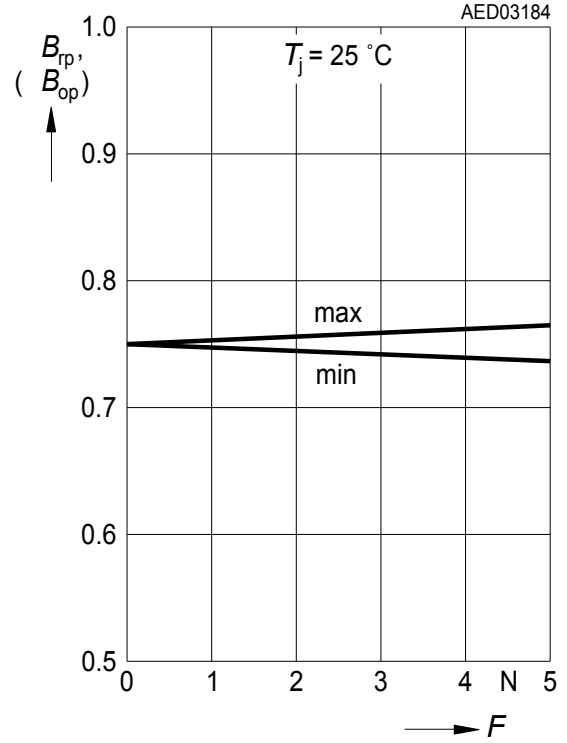

Filter Sensitivity versus Temperature

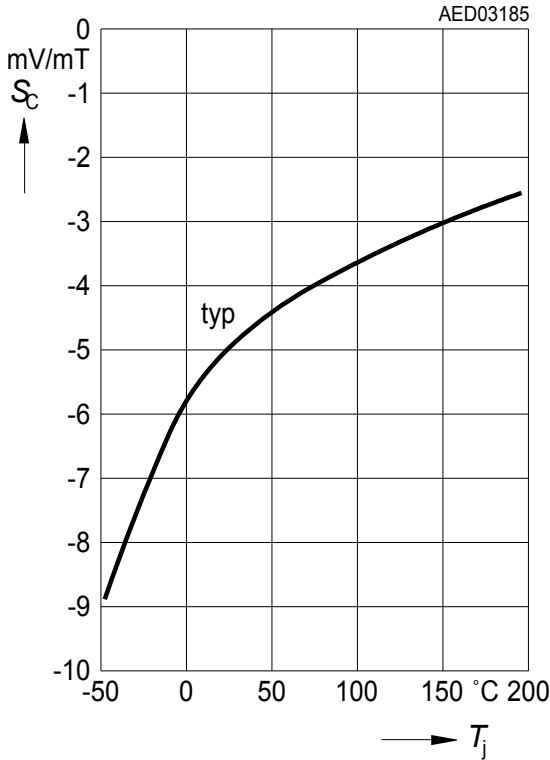

Filter Input Resistance versus Temperature

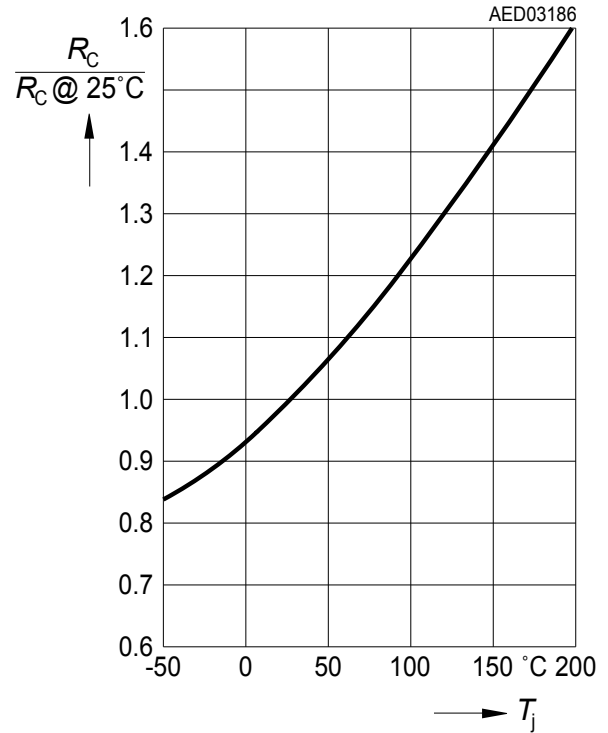

6 Typical performance characteristics

Delay Time for Power on (V_S Switching from 0 V to 4.5 V) t_{pon} versus Temp.

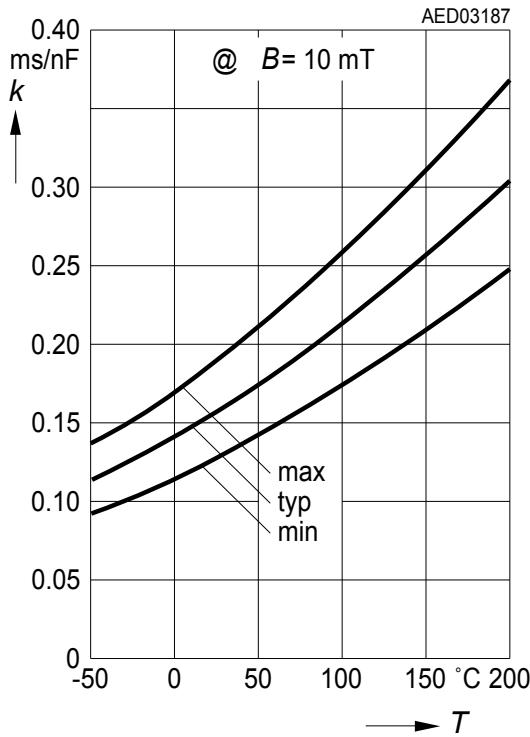

Periodjitter (1σ) versus Temperature

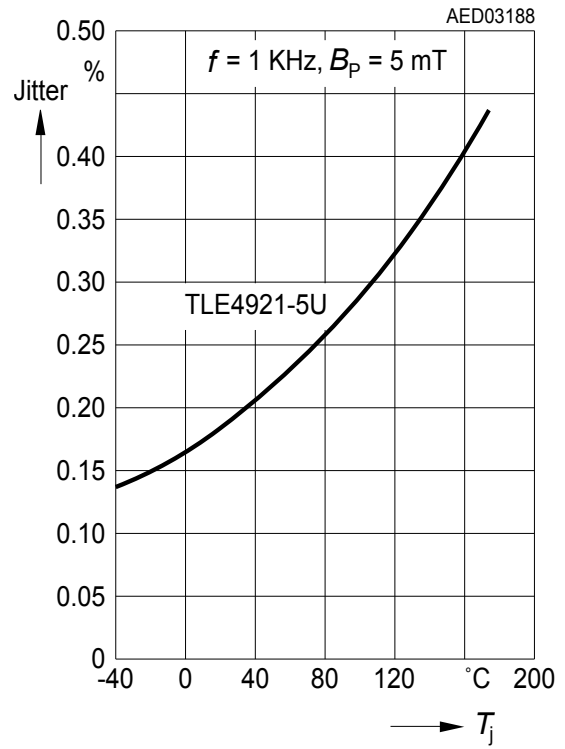

Table 6 Electro magnetic compatibility

ref. DIN 40839 part 1; test circuit 1

| Parameter | Symbol | Level/Typ | Status |
|--------------|----------|--------------|--------|
| Testpulse 1 | V_{LD} | IV / - 100 V | C |
| Testpulse 2 | | IV / 100 V | B |
| Testpulse 3a | | IV / - 150 V | C |
| Testpulse 3b | | IV / 100 V | C |
| Testpulse 4 | | IV / - 7 V | C |
| Testpulse 5 | | IV / 86.5 V | C |

Note: Stresses above those listed here may cause permanent damage to the device. Exposure to absolute maximum rating conditions for extended periods may affect device reliability.

6 Typical performance characteristics

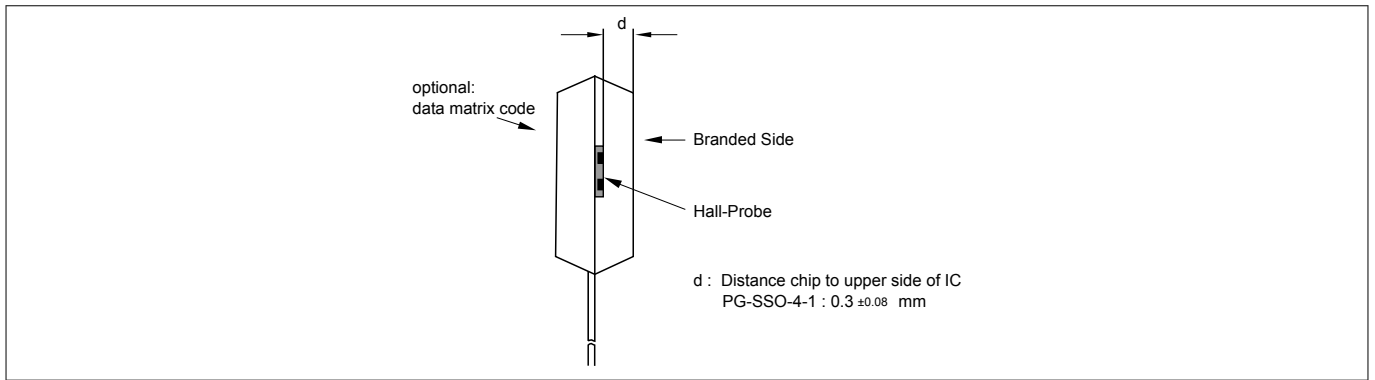

Figure 11 **Distance Chip to Upper Side of IC**

7 Package outlines

7 Package outlines

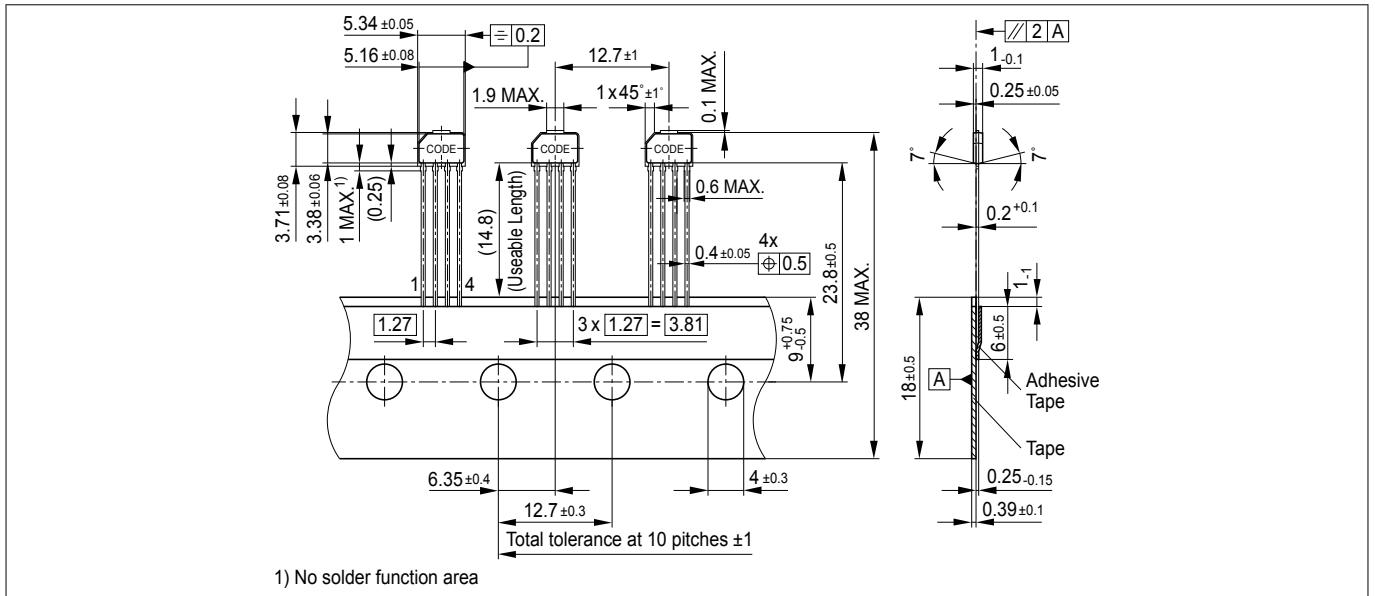

Figure 12 PG-SSO-4-1 (Plastic Single Small Outline Package)

You can find all of our packages, sorts of packing and others in our Infineon Internet Page “Products”: <http://www.infineon.com/products>. Dimensions in mm

8 Revision history

8 Revision history

Revision History

| Page | Subjects (major changes since last revision) |
|-------------------------------------|--|
| Revision History: 2020-11, Rev. 1.2 | |
| Previous Revisions: Rev. 1.1 | |
| 17 | Edited figure 11 (optional: data matrix code) |
| Rev. 1.0 | |
| 5 | Ordering Code changed |
| 11 | “Output leakage current” unit corrected |
| 20 | Figures “Delay Time between Switching Threshold” exchanged and corrected |
| 21 | Figure “Delay Time versus Differential Field” corrected |
| | |

Trademarks

All referenced product or service names and trademarks are the property of their respective owners.

Edition 2008-01

Published by
Infineon Technologies AG
81726 Munich, Germany

© 2021 Infineon Technologies AG
All Rights Reserved.

Do you have a question about any
aspect of this document?
Email: erratum@infineon.com

Document reference
IFX-jwo1598516982309

IMPORTANT NOTICE

The information given in this document shall in no event be regarded as a guarantee of conditions or characteristics ("Beschaffheitsgarantie").

With respect to any examples, hints or any typical values stated herein and/or any information regarding the application of the product, Infineon Technologies hereby disclaims any and all warranties and liabilities of any kind, including without limitation warranties of non-infringement of intellectual property rights of any third party.

In addition, any information given in this document is subject to customer's compliance with its obligations stated in this document and any applicable legal requirements, norms and standards concerning customer's products and any use of the product of Infineon Technologies in customer's applications.

The data contained in this document is exclusively intended for technically trained staff. It is the responsibility of customer's technical departments to evaluate the suitability of the product for the intended application and the completeness of the product information given in this document with respect to such application.

WARNINGS

Due to technical requirements products may contain dangerous substances. For information on the types in question please contact your nearest Infineon Technologies office.

Except as otherwise explicitly approved by Infineon Technologies in a written document signed by authorized representatives of Infineon Technologies, Infineon Technologies' products may not be used in any applications where a failure of the product or any consequences of the use thereof can reasonably be expected to result in personal injury.