



5 VOLT INTEL® StrataFlash™ MEMORY

28F320J5 and 28F640J5 (x8/x16)

- **High-Density Symmetrically-Blocked Architecture**
 - 64 128-Kbyte Erase Blocks (64 M)
 - 32 128-Kbyte Erase Blocks (32 M)
- **4.5 V–5.5 V V_{CC} Operation**
 - 2.7 V–3.6 V and 4.5 V–5.5 V I/O Capable
- **120 ns Read Access Time (32 M)**
150 ns Read Access Time (64 M)
- **Enhanced Data Protection Features**
 - Absolute Protection with V_{PEN} = GND
 - Flexible Block Locking
 - Block Erase/Program Lockout during Power Transitions
- **Industry-Standard Packaging**
 - SSOP Package (32, 64 M)
 - TSOP Package (32 M)
 - μBGA* Package (64 M)
- **Cross-Compatible Command Support**
 - Intel Basic Command Set
 - Common Flash Interface
 - Scaleable Command Set
- **32-Byte Write Buffer**
 - 6 μs per Byte Effective Programming Time
- **6,400,000 Total Erase Cycles (64 M)**
3,200,000 Total Erase Cycles (32 M)
 - 100,000 Erase Cycles per Block
- **Automation Suspend Options**
 - Block Erase Suspend to Read
 - Block Erase Suspend to Program
- **System Performance Enhancements**
 - STS Status Output

Capitalizing on two-bit-per-cell technology, 5 Volt Intel® StrataFlash™ memory products provide 2X the bits in 1X the space. Offered in 64-Mbit (8-Mbyte) and 32-Mbit (4-Mbyte) densities, Intel StrataFlash memory devices are the first to bring reliable, two-bit-per-cell storage technology to the flash market.

Intel StrataFlash memory benefits include: more density in less space, lowest cost-per-bit NOR devices, support for code and data storage, and easy migration to future devices.

Using the same NOR-based ETOX™ technology as Intel's one-bit-per-cell products, Intel StrataFlash memory devices take advantage of 400 million units of manufacturing experience since 1988. As a result, Intel StrataFlash components are ideal for code or data applications where high density and low cost are required. Examples include networking, telecommunications, audio recording, and digital imaging.

Intel StrataFlash memory components deliver a new generation of forward-compatible software support. By using the Common Flash Interface (CFI) and the Scaleable Command Set (SCS), customers can take advantage of density upgrades and optimized write capabilities of future Intel StrataFlash memory devices.

Manufactured on Intel's 0.4 micron ETOX™ V process technology, 5 Volt Intel StrataFlash memory provides the highest levels of quality and reliability.

NOTE: This document formerly known as *Intel® StrataFlash™ Memory Technology 32 and 64 Mbit*.

Information in this document is provided in connection with Intel products. No license, express or implied, by estoppel or otherwise, to any intellectual property rights is granted by this document. Except as provided in Intel's Terms and Conditions of Sale for such products, Intel assumes no liability whatsoever, and Intel disclaims any express or implied warranty, relating to sale and/or use of Intel products including liability or warranties relating to fitness for a particular purpose, merchantability, or infringement of any patent, copyright or other intellectual property right. Intel products are not intended for use in medical, life saving, or life sustaining applications.

Intel may make changes to specifications and product descriptions at any time, without notice.

The 28F320J5 and 28F640J4 may contain design defects or errors known as errata which may cause the product to deviate from published specifications. Current characterized errata are available on request.

Contact your local Intel sales office or your distributor to obtain the latest specifications and before placing your product order.

Copies of documents which have an ordering number and are referenced in this document, or other Intel literature, may be obtained from:

Intel Corporation
P.O. Box 5937
Denver, CO 8021-9808

or call 1-800-548-4725
or visit Intel's website at <http://www.intel.com>

COPYRIGHT © INTEL CORPORATION 1997, 1998, 1999

CG-041493

*Other brands and names are the property of their respective owners.



CONTENTS

PAGE	PAGE
1.0 PRODUCT OVERVIEW	5
2.0 PRINCIPLES OF OPERATION	11
2.1 Data Protection	12
3.0 BUS OPERATION	12
3.1 Read	13
3.2 Output Disable	13
3.3 Standby	13
3.4 Reset/Power-Down	13
3.5 Read Query	14
3.6 Read Identifier Codes	14
3.7 Write	14
4.0 COMMAND DEFINITIONS	14
4.1 Read Array Command	18
4.2 Read Query Mode Command	18
4.2.1 Query Structure Output	18
4.2.2 Query Structure Overview	20
4.2.3 Block Status Register	21
4.2.4 CFI Query Identification String	22
4.2.5 System Interface Information	22
4.2.6 Device Geometry Definition	23
4.2.7 Primary-Vendor Specific Extended Query Table	24
4.3 Read Identifier Codes Command	25
4.4 Read Status Register Command	26
4.5 Clear Status Register Command	26
4.6 Block Erase Command	26
4.7 Block Erase Suspend Command	27
4.8 Write to Buffer Command	27
4.9 Byte/Word Program Commands	28
4.10 Configuration Command	28
4.11 Set Block and Master Lock-Bit Commands	29
4.12 Clear Block Lock-Bits Command	29
5.0 DESIGN CONSIDERATIONS	40
5.1 Three-Line Output Control	40
5.2 STS and Block Erase, Program, and Lock-Bit Configuration Polling	40
5.3 Power Supply Decoupling	40
5.4 Input Signal Transitions – Reducing Overshoots and Undershoots When Using Buffers/Transceivers	40
5.5 V _{CC} , V _{PEN} , RP# Transitions	41
5.6 Power-Up/Down Protection	41
5.7 Power Dissipation	41
6.0 ELECTRICAL SPECIFICATIONS	42
6.1 Absolute Maximum Ratings	42
6.2 Operating Conditions	42
6.3 Capacitance	42
6.4 DC Characteristics	43
6.5 AC Characteristics—Read-Only Operations	46
6.6 AC Characteristics—Write Operations	48
6.7 Block Erase, Program, and Lock-Bit Configuration Performance	51
7.0 ORDERING INFORMATION	52
8.0 ADDITIONAL INFORMATION	53

REVISION HISTORY

Date of Revision	Version	Description
09/01/97	-001	Original Version
09/17/97	-002	Modifications made to cover sheet
12/01/97	-003	V _{CC} /GND Pins Converted to No Connects specification change added I _{CCS} , I _{CCD} , I _{CCW} , and I _{CCOE} specification change added Order Codes specification change added
01/31/98	-004	The μ BGA* chip-scale package in Figure 2 was changed to a 52-ball package and appropriate documentation added. The 64-Mb μ BGA package dimensions were changed in Figure 2. Changed Figure 4 to read SSOP instead of TSOP.
03/23/98	-005	32-Mbit Intel StrataFlash memory read access time added. The number of block erase cycles was changed. The write buffer program time was changed. The operating temperature was changed. A read parameter was added. Several program, erase, and lock-bit specifications were changed. Minor documentation changes were made as well. Datasheet designation changed from Advance Information to Preliminary.
07/13/98	-006	Intel StrataFlash memory 32-Mb μ BGA package removed. t _{EH} EL read specification reduced. Table 4 was modified. The <i>Ordering Information</i> was updated.
12/01/98	-007	Removed 32 Mbit, 100 ns references and ordering information for same. Provided clearer V _{OH} specifications. Provided maximum program/erase specifications. Added <i>Input Signal Transitions – Reducing Overshoots and Undershoots When Using Buffers/Transceivers to Design Considerations</i> section. Name of document changed from <i>Intel® StrataFlash™ Memory Technology 32 and 64 Mbit</i> .
05/04/99	-008	Updated CFI Tables, Section 4.2.1—Section 4.2.7

1.0 PRODUCT OVERVIEW

The Intel® StrataFlash™ memory family contains high-density memories organized as 8 Mbytes or 4 Mwords (64-Mbit) and 4 Mbytes or 2 Mwords (32-Mbit). These devices can be accessed as 8- or 16-bit words. The 64-Mbit device is organized as sixty-four 128-Kbyte (131,072 bytes) erase blocks while the 32-Mbit device contains thirty-two 128-Kbyte erase blocks. Blocks are selectively and individually lockable and unlockable in-system. See the memory map in Figure 5.

A Common Flash Interface (CFI) permits software algorithms to be used for entire families of devices. This allows device-independent, JEDEC ID-independent, and forward- and backward-compatible software support for the specified flash device families. Flash vendors can standardize their existing interfaces for long-term compatibility.

Scaleable Command Set (SCS) allows a single, simple software driver in all host systems to work with all SCS-compliant flash memory devices, independent of system-level packaging (e.g., memory card, SIMM, or direct-to-board placement). Additionally, SCS provides the highest system/device data transfer rates and minimizes device and system-level implementation costs.

A Command User Interface (CUI) serves as the interface between the system processor and internal operation of the device. A valid command sequence written to the CUI initiates device automation. An internal Write State Machine (WSM) automatically executes the algorithms and timings necessary for block erase, program, and lock-bit configuration operations.

A block erase operation erases one of the device's 128-Kbyte blocks typically within one second— independent of other blocks. Each block can be independently erased 100,000 times. Block erase suspend mode allows system software to suspend block erase to read or program data from any other block.

Each device incorporates a Write Buffer of 32 bytes (16 words) to allow optimum programming performance. By using the Write Buffer, data is programmed in buffer increments. This feature can improve system program performance by up to 20 times over non-Write Buffer writes.

Individual block locking uses a combination of bits, block lock-bits and a master lock-bit, to lock and unlock blocks. Block lock-bits gate block erase and program operations while the master lock-bit gates block lock-bit modification. Three lock-bit configuration operations set and clear lock-bits (Set Block Lock-Bit, Set Master Lock-Bit, and Clear Block Lock-Bits commands).

The status register indicates when the WSM's block erase, program, or lock-bit configuration operation is finished.

The STS (STATUS) output gives an additional indicator of WSM activity by providing both a hardware signal of status (versus software polling) and status masking (interrupt masking for background block erase, for example). Status indication using STS minimizes both CPU overhead and system power consumption. When configured in level mode (default mode), it acts as a RY/BY# pin. When low, STS indicates that the WSM is performing a block erase, program, or lock-bit configuration. STS-high indicates that the WSM is ready for a new command, block erase is suspended (and programming is inactive), or the device is in reset/power-down mode. Additionally, the configuration command allows the STS pin to be configured to pulse on completion of programming and/or block erases.

Three CE pins are used to enable and disable the device. A unique CE logic design (see Table 2, *Chip Enable Truth Table*) reduces decoder logic typically required for multi-chip designs. External logic is not required when designing a single chip, a dual chip, or a 4-chip miniature card or SIMM module.

The BYTE# pin allows either x8 or x16 read/writes to the device. BYTE# at logic low selects 8-bit mode; address A₀ selects between the low byte and high byte. BYTE# at logic high enables 16-bit operation; address A₁ becomes the lowest order address and address A₀ is not used (don't care). A device block diagram is shown in Figure 1.

When the device is disabled (see Table 2, *Chip Enable Truth Table*) and the RP# pin is at V_{CC}, the standby mode is enabled. When the RP# pin is at GND, a further power-down mode is enabled which minimizes power consumption and provides write protection during reset. A reset time (t_{PHQV}) is required from RP# switching high until outputs

are valid. Likewise, the device has a wake time (t_{PHWL}) from RP#-high until writes to the CUI are recognized. With RP# at GND, the WSM is reset and the status register is cleared.

available in 56-lead SSOP (Shrink Small Outline Package) and μ BGA* package (micro Ball Grid Array). The 32-Mbit is available in 56-lead TSOP (Thin Small Outline Package) and 56-lead SSOP. Figures 2, 3, and 4 show the pinouts.

The Intel StrataFlash memory devices are available in several package types. The 64-Mbit is

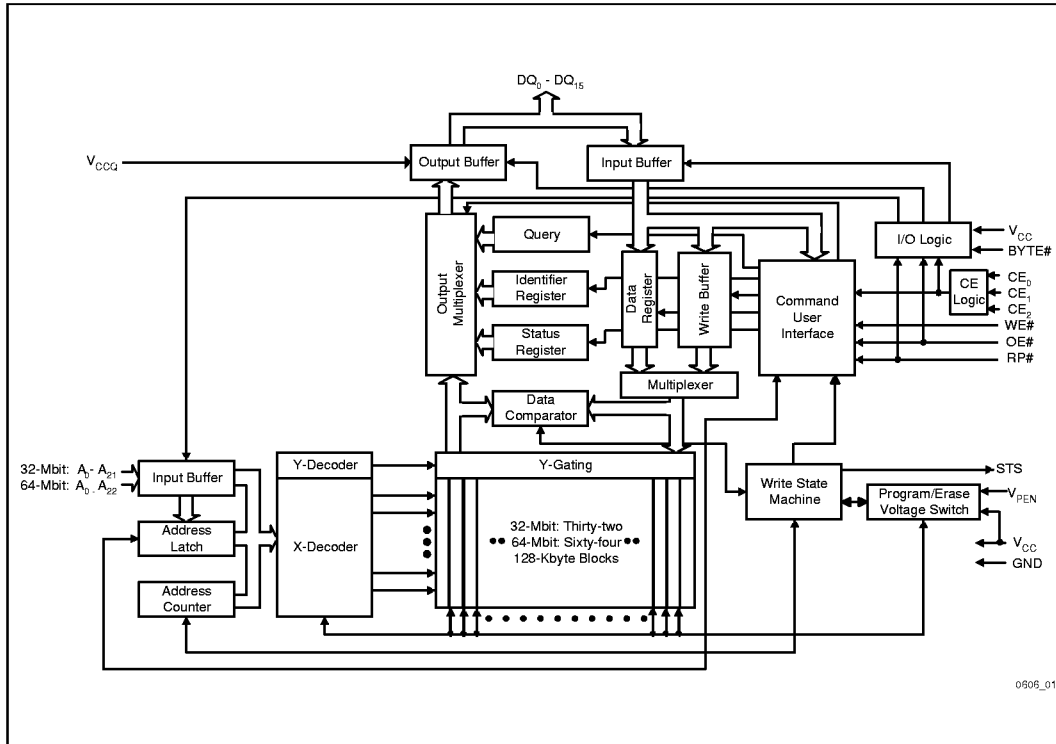

Figure 1. Intel® StrataFlash™ Memory Block Diagram

Table 1. Lead Descriptions

Symbol	Type	Name and Function
A ₀	INPUT	BYTE-SELECT ADDRESS: Selects between high and low byte when the device is in x8 mode. This address is latched during a x8 program cycle. Not used in x16 mode (i.e., the A ₀ input buffer is turned off when BYTE# is high).
A ₁ –A ₂₂	INPUT	ADDRESS INPUTS: Inputs for addresses during read and program operations. Addresses are internally latched during a program cycle. 32-Mbit: A ₀ –A ₂₁ 64-Mbit: A ₀ –A ₂₂
DQ ₀ –DQ ₇	INPUT/ OUTPUT	LOW-BYTE DATA BUS: Inputs data during buffer writes and programming, and inputs commands during Command User Interface (CUI) writes. Outputs array, query, identifier, or status data in the appropriate read mode. Floated when the chip is de-selected or the outputs are disabled. Outputs DQ ₆ –DQ ₀ are also floated when the Write State Machine (WSM) is busy. Check SR.7 (status register bit 7) to determine WSM status.
DQ ₈ –DQ ₁₅	INPUT/ OUTPUT	HIGH-BYTE DATA BUS: Inputs data during x16 buffer writes and programming operations. Outputs array, query, or identifier data in the appropriate read mode; not used for status register reads. Floated when the chip is de-selected, the outputs are disabled, or the WSM is busy.
CE ₀ , CE ₁ , CE ₂	INPUT	CHIP ENABLES: Activates the device's control logic, input buffers, decoders, and sense amplifiers. When the device is de-selected (see Table 2, <i>Chip Enable Truth Table</i>), power reduces to standby levels. All timing specifications are the same for these three signals. Device selection occurs with the first edge of CE ₀ , CE ₁ , or CE ₂ that enables the device. Device deselection occurs with the first edge of CE ₀ , CE ₁ , or CE ₂ that disables the device (see Table 2, <i>Chip Enable Truth Table</i>).
RP#	INPUT	RESET/ POWER-DOWN: Resets internal automation and puts the device in power-down mode. RP#-high enables normal operation. Exit from reset sets the device to read array mode. When driven low, RP# inhibits write operations which provides data protection during power transitions. RP# at V _{HH} enables master lock-bit setting and block lock-bits configuration when the master lock-bit is set. RP# = V _{HH} overrides block lock-bits thereby enabling block erase and programming operations to locked memory blocks. Do not permanently connect RP# to V _{HH} .
OE#	INPUT	OUTPUT ENABLE: Activates the device's outputs through the data buffers during a read cycle. OE# is active low.
WE#	INPUT	WRITE ENABLE: Controls writes to the Command User Interface, the Write Buffer, and array blocks. WE# is active low. Addresses and data are latched on the rising edge of the WE# pulse.
STS	OPEN DRAIN OUTPUT	STATUS: Indicates the status of the internal state machine. When configured in level mode (default mode), it acts as a RY/BY# pin. When configured in one of its pulse modes, it can pulse to indicate program and/or erase completion. For alternate configurations of the STATUS pin, see the Configurations command. Tie STS to V _{CCQ} with a pull-up resistor.

Table 1. Lead Descriptions (Continued)

Symbol	Type	Name and Function
BYTE#	INPUT	BYTE ENABLE: BYTE# low places the device in x8 mode. All data is then input or output on DQ ₀ –DQ ₇ , while DQ ₈ –DQ ₁₅ float. Address A ₀ selects between the high and low byte. BYTE# high places the device in x16 mode, and turns off the A ₀ input buffer. Address A ₁ then becomes the lowest order address.
V _{PEN}	INPUT	ERASE / PROGRAM / BLOCK LOCK ENABLE: For erasing array blocks, programming data, or configuring lock-bits. With V _{PEN} ≤ V _{PENLK} , memory contents cannot be altered.
V _{CC}	SUPPLY	DEVICE POWER SUPPLY: With V _{CC} ≤ V _{LKO} , all write attempts to the flash memory are inhibited.
V _{CCQ}	OUTPUT BUFFER SUPPLY	OUTPUT BUFFER POWER SUPPLY: This voltage controls the device's output voltages. To obtain output voltages compatible with system data bus voltages, connect V _{CCQ} to the system supply voltage.
GND	SUPPLY	GROUND: Do not float any ground pins.
NC		NO CONNECT: Lead is not internally connected; it may be driven or floated.

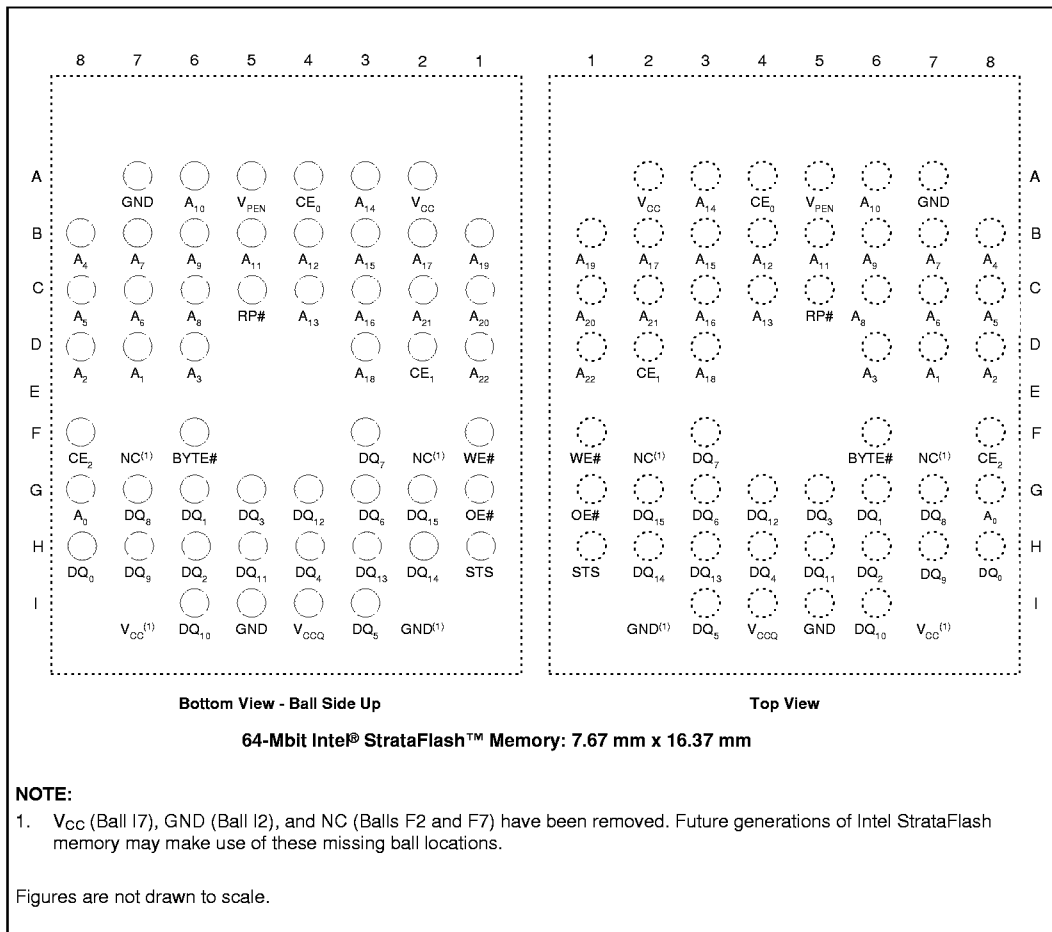

Figure 2. μBGA* Package (64 Mbit)

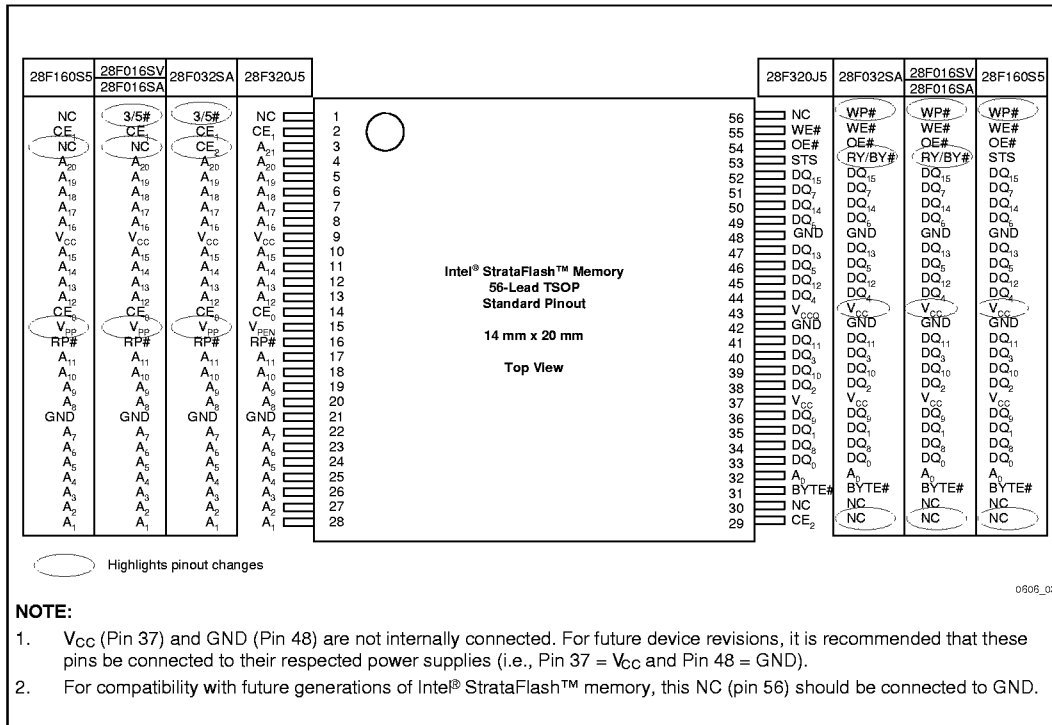

Figure 3. TSOP Lead Configuration (32 Mbit)

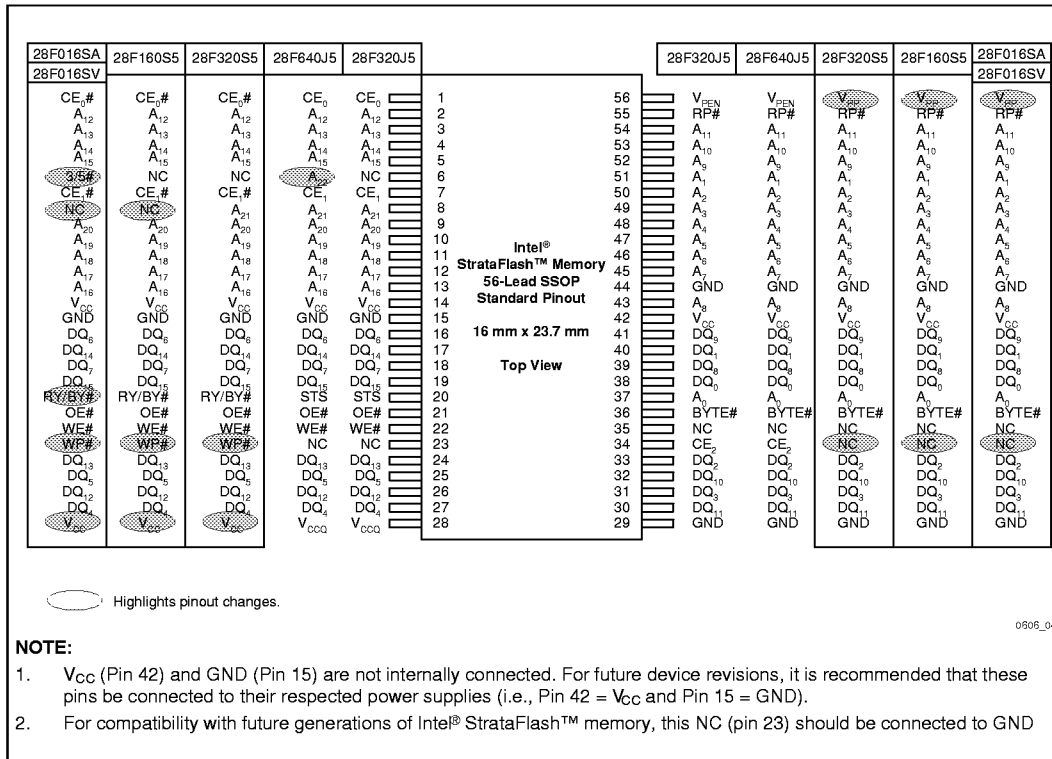

Figure 4. SSOP Lead Configuration (64 Mbit and 32 Mbit)

2.0 PRINCIPLES OF OPERATION

The Intel StrataFlash memory devices include an on-chip WSM to manage block erase, program, and lock-bit configuration functions. It allows for 100% TTL-level control inputs, fixed power supplies during block erasure, program, lock-bit configuration, and minimal processor overhead with RAM-like interface timings.

After initial device power-up or return from reset/power-down mode (see *Bus Operations*), the device defaults to read array mode. Manipulation of external memory control pins allows array read, standby, and output disable operations.

Read array, status register, query, and identifier codes can be accessed through the CUI (Command User Interface) independent of the V_{PEN} voltage.

V_{PENH} on V_{PEN} enables successful block erasure, programming, and lock-bit configuration. All functions associated with altering memory contents—block erase, program, lock-bit configuration—are accessed via the CUI and verified through the status register.

Commands are written using standard micro-processor write timings. The CUI contents serve as input to the WSM, which controls the block erase, program, and lock-bit configuration. The internal algorithms are regulated by the WSM, including pulse repetition, internal verification, and margining of data. Addresses and data are internally latched during program cycles.

Interface software that initiates and polls progress of block erase, program, and lock-bit configuration can be stored in any block. This code is copied to and executed from system RAM during flash memory updates. After successful completion, reads are again possible via the Read Array command. Block erase suspend allows system software to suspend a block erase to read or program data from/to any other block.

2.1 Data Protection

Depending on the application, the system designer may choose to make the V_{PEN} switchable (available only when memory block erases, programs, or lock-bit configurations are required) or hardwired to V_{PENH} . The device accommodates either design practice and encourages optimization of the processor-memory interface.

When $V_{PEN} \leq V_{PENLK}$, memory contents cannot be altered. The CUI's two-step block erase, byte/word program, and lock-bit configuration command sequences provide protection from unwanted operations even when V_{PENH} is applied to V_{PEN} . All program functions are disabled when V_{CC} is below the write lockout voltage V_{LKO} or when $RP\#$ is V_{IL} . The device's block locking capability provides additional protection from inadvertent code or data alteration by gating erase and program operations.

3.0 BUS OPERATION

The local CPU reads and writes flash memory in-system. All bus cycles to or from the flash memory conform to standard microprocessor bus cycles.

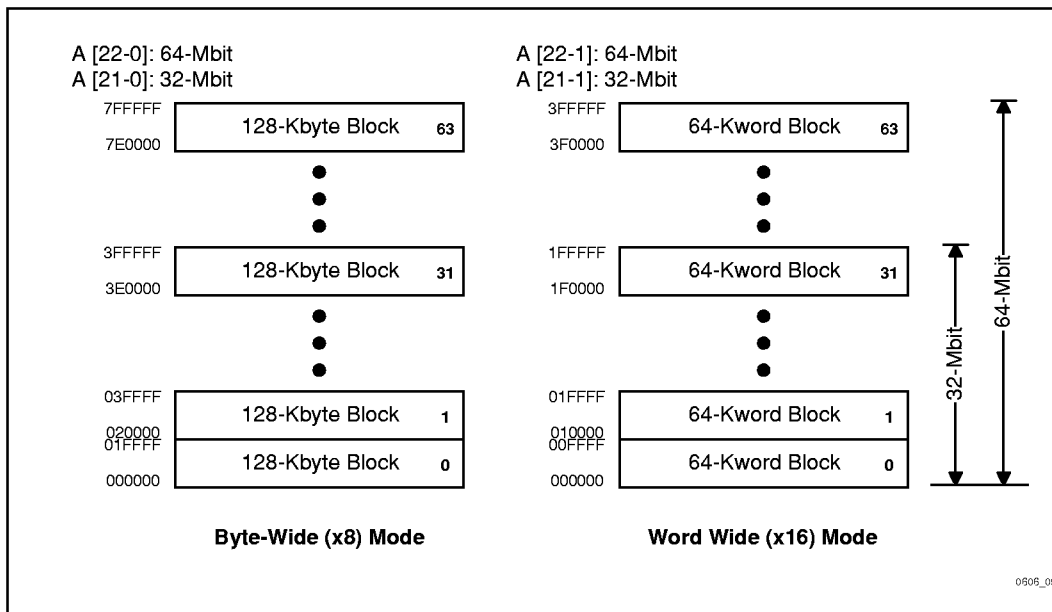

Figure 5. Memory Map

Table 2. Chip Enable Truth Table^(1,2)

CE ₂	CE ₁	CE ₀	DEVICE
V _{IL}	V _{IL}	V _{IL}	Enabled
V _{IL}	V _{IL}	V _{IH}	Disabled
V _{IL}	V _{IH}	V _{IL}	Disabled
V _{IL}	V _{IH}	V _{IH}	Disabled
V _{IH}	V _{IL}	V _{IL}	Enabled
V _{IH}	V _{IL}	V _{IH}	Enabled
V _{IH}	V _{IH}	V _{IL}	Enabled
V _{IH}	V _{IH}	V _{IH}	Disabled

NOTE:

1. See Application Note *AP-647 5 Volt Intel® StrataFlash™ Memory Design Guide* for typical CE configurations.
2. For single-chip applications CE₂ and CE₁ can be strapped to GND.

3.1 Read

Information can be read from any block, query, identifier codes, or status register independent of the V_{PEN} voltage. RP# can be at either V_{IH} or V_{HH}.

Upon initial device power-up or after exit from reset/power-down mode, the device automatically resets to read array mode. Otherwise, write the appropriate read mode command (Read Array, Read Query, Read Identifier Codes, or Read Status Register) to the CUI. Six control pins dictate the data flow in and out of the component: CE₀, CE₁, CE₂, OE#, WE#, and RP#. The device must be enabled (see Table 2, *Chip Enable Truth Table*), and OE# must be driven active to obtain data at the outputs. CE₀, CE₁, and CE₂ are the device selection controls and, when enabled (see Table 2, *Chip Enable Truth Table*), select the memory device. OE# is the data output (DQ₀–DQ₁₅) control and, when active, drives the selected memory data onto the I/O bus. WE# must be at V_{IH}.

3.2 Output Disable

With OE# at a logic-high level (V_{IH}), the device outputs are disabled. Output pins DQ₀–DQ₁₅ are placed in a high-impedance state.

3.3 Standby

CE₀, CE₁, and CE₂ can disable the device (see Table 2, *Chip Enable Truth Table*) and place it in standby mode which substantially reduces device power consumption. DQ₀–DQ₁₅ outputs are placed in a high-impedance state independent of OE#. If deselected during block erase, program, or lock-bit configuration, the WSM continues functioning, and consuming active power until the operation completes.

3.4 Reset/Power-Down

RP# at V_{IL} initiates the reset/power-down mode.

In read modes, RP#-low deselects the memory, places output drivers in a high-impedance state, and turns off numerous internal circuits. RP# must be held low for a minimum of t_{PLPH}. Time t_{PHQV} is required after return from reset mode until initial memory access outputs are valid. After this wake-up interval, normal operation is restored. The CUI is reset to read array mode and status register is set to 80H.

During block erase, program, or lock-bit configuration modes, RP#-low will abort the operation. In default mode, STS transitions low and remains low for a maximum time of t_{PLPH} + t_{PHRH} until the reset operation is complete. Memory contents being altered are no longer valid; the data may be partially corrupted after a program or partially altered after an erase or lock-bit configuration. Time t_{PHWL} is required after RP# goes to logic-high (V_{IH}) before another command can be written.

As with any automated device, it is important to assert RP# during system reset. When the system comes out of reset, it expects to read from the flash memory. Automated flash memories provide status information when accessed during block erase, program, or lock-bit configuration modes. If a CPU reset occurs with no flash memory reset, proper initialization may not occur because the flash memory may be providing status information instead of array data. Intel® Flash memories allow proper initialization following a system reset through the use of the RP# input. In this application, RP# is controlled by the same RESET# signal that resets the system CPU.

3.5 Read Query

The read query operation outputs block status information, CFI (Common Flash Interface) ID string, system interface information, device geometry information, and Intel-specific extended query information.

3.6 Read Identifier Codes

The read identifier codes operation outputs the manufacturer code, device code, block lock configuration codes for each block, and the master lock configuration code (see Figure 6). Using the manufacturer and device codes, the system CPU can automatically match the device with its proper algorithms. The block lock and master lock configuration codes identify locked and unlocked blocks and master lock-bit setting.

3.7 Write

Writing commands to the CUI enables reading of device data, query, identifier codes, inspection and clearing of the status register, and, when $V_{PEN} = V_{PENH}$, block erasure, program, and lock-bit configuration.

The Block Erase command requires appropriate command data and an address within the block to be erased. The Byte/Word Program command requires the command and address of the location to be written. Set Master and Block Lock-Bit commands require the command and address within the device (Master Lock) or block within the device (Block Lock) to be locked. The Clear Block Lock-Bits command requires the command and address within the device.

The CUI does not occupy an addressable memory location. It is written when the device is enabled and $WE\#$ is active. The address and data needed to execute a command are latched on the rising edge of $WE\#$ or the first edge of CE_0 , CE_1 , or CE_2 that disables the device (see Table 2, *Chip Enable Truth Table*). Standard microprocessor write timings are used.

4.0 COMMAND DEFINITIONS

When the V_{PEN} voltage $\leq V_{PENLK}$, only read operations from the status register, query, identifier codes, or blocks are enabled. Placing V_{PENH} on

V_{PEN} additionally enables block erase, program, and lock-bit configuration operations.

Device operations are selected by writing specific commands into the CUI. Table 4 defines these commands.

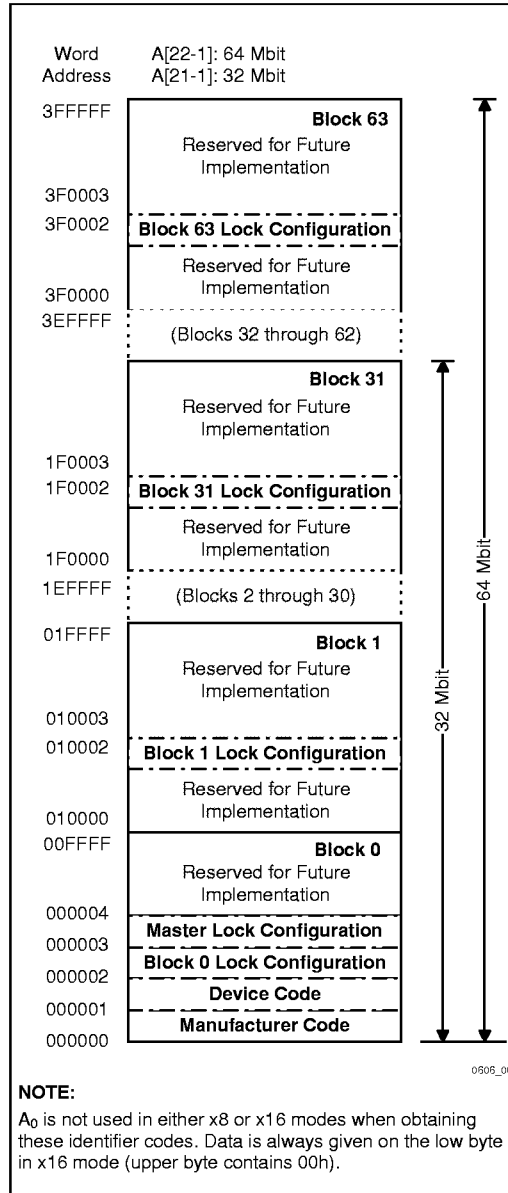

Figure 6. Device Identifier Code Memory Map

PRELIMINARY

Table 3. Bus Operations

Mode	Notes	RP#	CE _{0,1,2} (¹⁰)	OE#(¹¹)	WE#(¹¹)	Address	V _{PEN}	DQ(⁸)	STS (default mode)
Read Array	1,2,3	V _{IH} or V _{HH}	Enabled	V _{IL}	V _{IH}	X	X	D _{OUT}	High Z(⁹)
Output Disable		V _{IH} or V _{HH}	Enabled	V _{IH}	V _{IH}	X	X	High Z	X
Standby		V _{IH} or V _{HH}	Disabled	X	X	X	X	High Z	X
Reset/Power-Down Mode		V _{IL}	X	X	X	X	X	High Z	High Z(⁹)
Read Identifier Codes		V _{IH} or V _{HH}	Enabled	V _{IL}	V _{IH}	See Figure 6	X	Note 4	High Z(⁹)
Read Query		V _{IH} or V _{HH}	Enabled	V _{IL}	V _{IH}	See Table 7	X	Note 5	High Z(⁹)
Read Status (WSM off)		V _{IH} or V _{HH}	Enabled	V _{IL}	V _{IH}	X	X	D _{OUT}	
Read Status (WSM on)		V _{IH} or V _{HH}	Enabled	V _{IL}	V _{IH}	X	V _{PENH}	DQ ₇ = D _{OUT} DQ ₁₅₋₈ = High Z DQ ₆₋₀ = High Z	
Write	3,6,7	V _{IH} or V _{HH}	Enabled	V _{IH}	V _{IL}	X	X	D _{IN}	X

NOTES:

1. Refer to *DC Characteristics*. When $V_{PEN} \leq V_{PENLK}$, memory contents can be read, but not altered.
2. X can be V_{IL} or V_{IH} for control and address pins, and V_{PENLK} or V_{PENH} for V_{PEN}. See *DC Characteristics* for V_{PENLK} and V_{PENH} voltages.
3. In default mode, STS is V_{OL} when the WSM is executing internal block erase, program, or lock-bit configuration algorithms. It is V_{OH} when the WSM is not busy, in block erase suspend mode (with programming inactive), or reset/power-down mode.
4. See *Read Identifier Codes Command* section for read identifier code data.
5. See *Read Query Mode Command* section for read query data.
6. Command writes involving block erase, program, or lock-bit configuration are reliably executed when V_{PEN} = V_{PENH} and V_{CC} is within specification. Block erase, program, or lock-bit configuration with V_{IH} < RP# < V_{HH} produce spurious results and should not be attempted.
7. Refer to Table 4 for valid D_{IN} during a write operation.
8. DQ refers to DQ₀–DQ₇ if BYTE# is low and DQ₀–DQ₁₅ if BYTE# is high.
9. High Z will be V_{OH} with an external pull-up resistor.
10. See Table 2 for valid CE configurations.
11. OE# and WE# should never be enabled simultaneously.

Table 4. Intel® StrataFlash™ Memory Command Set Definitions⁽¹⁴⁾

Command	Scaleable or Basic Command Set ⁽¹⁵⁾	Bus Cycles Req'd.	Notes	First Bus Cycle			Second Bus Cycle		
				Oper ⁽¹⁾	Addr ⁽²⁾	Data ^(3,4)	Oper ⁽¹⁾	Addr ⁽²⁾	Data ^(3,4)
Read Array	SCS/BCS	1		Write	X	FFH			
Read Identifier Codes	SCS/BCS	≥ 2	5	Write	X	90H	Read	IA	ID
Read Query	SCS	≥ 2		Write	X	98H	Read	QA	QD
Read Status Register	SCS/BCS	2	6	Write	X	70H	Read	X	SRD
Clear Status Register	SCS/BCS	1		Write	X	50H			
Write to Buffer	SCS/BCS	> 2	7,8,9	Write	BA	E8H	Write	BA	N
Word/Byte Program	SCS/BCS	2	10,11	Write	PA	40H or 10H	Write	PA	PD
Block Erase	SCS/BCS	2	9,10	Write	BA	20H	Write	BA	D0H
Block Erase Suspend	SCS/BCS	1	9,10	Write	X	B0H			
Block Erase Resume	SCS/BCS	1	10	Write	X	D0H			
Configuration	SCS	2		Write	X	B8H	Write	X	CC
Set Block Lock-Bit	SCS	2	12	Write	BA	60H	Write	BA	01H
Clear Block Lock-Bits	SCS	2	13	Write	X	60H	Write	X	D0H
Set Master Lock-Bit		2	12,13	Write	X	60H	Write	X	F1H

NOTES:

1. Bus operations are defined in Table 3.
2. X = Any valid address within the device.
BA = Address within the block.
IA = Identifier Code Address: see Figure 6 and Table 13.
QA = Query database Address.
PA = Address of memory location to be programmed.
3. ID = Data read from Identifier Codes.
QD = Data read from Query database.
SRD = Data read from status register. See Table 16 for a description of the status register bits.
PD = Data to be programmed at location PA. Data is latched on the rising edge of WE#.
CC = Configuration Code.
4. The upper byte of the data bus (DQ₈–DQ₁₅) during command writes is a "Don't Care" in x16 operation.
5. Following the Read Identifier Codes command, read operations access manufacturer, device, block lock, and master lock codes. See *Read Identifier Codes Command* section for read identifier code data.
6. If the WSM is running, only DQ₇ is valid; DQ₁₅–DQ₈ and DQ₆–DQ₀ float, which places them in a high-impedance state.
7. After the Write to Buffer command is issued check the XSR to make sure a buffer is available for writing.
8. The number of bytes/words to be written to the Write Buffer = N + 1, where N = byte/word count argument. Count ranges on this device for byte mode are N = 00H to N = 1FH and for word mode are N = 0000H to N = 000FH. The third and consecutive bus cycles, as determined by N, are for writing data into the Write Buffer. The Confirm command (D0H) is expected after exactly N + 1 write cycles; any other command at that point in the sequence aborts the write to buffer operation. Please see Figure 7, *Write to Buffer Flowchart*, for additional information.
9. Programming the write buffer to flash or initiating the erase operation does not begin until a confirm command (D0h) is issued.
10. If the block is locked, RP# must be at V_{HH} to enable block erase or program operations. Attempts to issue a block erase or program to a locked block while RP# is V_{IH} will fail.
11. Either 40H or 10H are recognized by the WSM as the byte/word program setup.
12. If the master lock-bit is set, RP# must be at V_{HH} to set a block lock-bit. RP# must be at V_{HH} to set the master lock-bit. If the master lock-bit is not set, a block lock-bit can be set while RP# is V_{IH}.
13. If the master lock-bit is set, RP# must be at V_{HH} to clear block lock-bits. The clear block lock-bits operation simultaneously clears all block lock-bits. If the master lock-bit is not set, the Clear Block Lock-Bits command can be done while RP# is V_{IH}.
14. Commands other than those shown above are reserved by Intel for future device implementations and should not be used.
15. The Basic Command Set (BCS) is the same as the 28F008SA Command Set or Intel Standard Command Set. The Scaleable Command Set (SCS) is also referred to as the Intel Extended Command Set.

4.1 Read Array Command

Upon initial device power-up and after exit from reset/power-down mode, the device defaults to read array mode. This operation is also initiated by writing the Read Array command. The device remains enabled for reads until another command is written. Once the internal WSM has started a block erase, program, or lock-bit configuration, the device will not recognize the Read Array command until the WSM completes its operation unless the WSM is suspended via an Erase Suspend command. The Read Array command functions independently of the V_{PEN} voltage and RP# can be V_{IH} or V_{HH} .

4.2 Read Query Mode Command

This section defines the data structure or "database" returned by the Common Flash Interface (CFI) Query command. System software should parse this structure to gain critical information such as block size, density, x8/x16, and electrical specifications. Once this information has been obtained, the software will know which command sets to use to enable flash writes, block erases, and otherwise control the flash component. The Query is part of an overall specification for multiple command set and control interface descriptions called Common Flash Interface, or CFI.

4.2.1 QUERY STRUCTURE OUTPUT

The Query "database" allows system software to gain information for controlling the flash component. This section describes the device's CFI-compliant interface that allows the host system to access Query data.

Query data are always presented on the lowest-order data outputs (DQ_{0-7}) only. The numerical offset value is the address relative to the maximum bus width supported by the device. On this family of devices, the Query table device starting address is a 10h, which is a word address for x16 devices.

For a word-wide (x16) device, the first two bytes of the Query structure, "Q" and "R" in ASCII, appear on the low byte at word addresses 10h and 11h. This CFI-compliant device outputs 00H data on upper bytes. Thus, the device outputs ASCII "Q" in the low byte (DQ_{0-7}) and 00h in the high byte (DQ_{8-15}).

At Query addresses containing two or more bytes of information, the least significant data byte is presented at the lower address, and the most significant data byte is presented at the higher address.

In all of the following tables, addresses and data are represented in hexadecimal notation, so the "h" suffix has been dropped. In addition, since the upper byte of word-wide devices is always "00h," the leading "00" has been dropped from the table notation and only the lower byte value is shown. Any x16 device outputs can be assumed to have 00h on the upper byte in this mode.

Table 5. Summary of Query Structure Output as a Function of Device and Mode

Device Type/ Mode	Query start location in maximum device bus width addresses	Query data with maximum device bus width addressing			Query data with byte addressing		
		Hex Offset	Hex Code	ASCII Value	Hex Offset	Hex Code	ASCII Value
x16 device x16 mode	10h	10:	0051	"Q"	20:	51	"Q"
		11:	0052	"R"	21:	00	"Null"
		12:	0059	"Y"	22:	52	"R"
x16 device x8 mode	N/A(1)	N/A(1)			20:	51	"Q"
					21:	51	"Q"
					22:	52	"R"

NOTE:

1. The system must drive the lowest order addresses to access all the device's array data when the device is configured in x8 mode. Therefore, word addressing, where these lower addresses are not toggled by the system, is "Not Applicable" for x8-configured devices.

Table 6. Example of Query Structure Output of a x16- and x8-Capable Device

Word Addressing			Byte Addressing		
Offset	Hex Code	Value	Offset	Hex Code	Value
A₁₅-A₀	D₁₅-D₀		A₇-A₀	D₇-D₀	
0010h	0051	"Q"	20h	51	"Q"
0011h	0052	"R"	21h	51	"Q"
0012h	0059	"Y"	22h	52	"R"
0013h	P_ID _{LO}	PrVendor	23h	52	"R"
0014h	P_ID _{HI}	ID #	24h	59	"Y"
0015h	P _{LO}	PrVendor	25h	59	"Y"
0016h	P _{HI}	TblAdr	26h	P_ID _{LO}	PrVendor
0017h	A_ID _{LO}	AltVendor	27h	P_ID _{LO}	ID #
0018h	A_ID _{HI}	ID #	28h	P_ID _{HI}	ID #
...

4.2.2 QUERY STRUCTURE OVERVIEW

The Query command causes the flash component to display the Common Flash Interface (CFI) Query structure or “database.” See *AP-646 Common Flash Interface (CFI) and Command Sets* (order number 292204) for a full description of CFI.

The following sections describe the Query structure sub-sections in detail.

Table 7. Query Structure⁽¹⁾

Offset	Sub-Section Name	Description
00h		Manufacturer Code
01h		Device Code
(BA+2)h ⁽²⁾	Block Status Register	Block-Specific Information
04-0Fh	Reserved	Reserved for Vendor-Specific Information
10h	CFI Query Identification String	Reserved for Vendor-Specific Information
1Bh	System Interface Information	Command Set ID and Vendor Data Offset
27h	Device Geometry Definition	Flash Device Layout
P ⁽³⁾	Primary Intel-Specific Extended Query Table	Vendor-Defined Additional Information Specific to the Primary Vendor Algorithm

NOTES:

1. Refer to the Query Structure Output section and offset 28h for the detailed definition of offset address as a function of device bus width and mode.
2. BA = Block Address beginning location (i.e., 02000h is block 2's beginning location when the block size is 128 Kbyte).
3. Offset 15 defines “P” which points to the Primary Intel-Specific Extended Query Table.

4.2.3 BLOCK STATUS REGISTER

The Block Status Register indicates whether an erase operation completed successfully or whether a given block is locked or can be accessed for flash program/erase operations.

Block Erase Status (BSR.1) allows system software to determine the success of the last block erase operation. BSR.1 can be used just after power-up to verify that the V_{CC} supply was not accidentally removed during an erase operation. This bit is only reset by issuing another erase operation to the block. The Block Status Register is accessed from word address 02h within each block.

Table 8. Block Status Register

Offset	Length	Description	Add.	Value
(BA+2)h ⁽¹⁾	1	Block Lock Status Register	BA+2:	--00 or --01
		BSR.0 Block Lock Status 0 = Unlocked 1 = Locked	BA+2:	(bit 0): 0 or 1
		BSR.1 Block Erase Status ⁽²⁾ 0 = Last erase operation completed successfully 1 = Last erase operation did not complete successfully	BA+2:	(bit 1): 0 or 1
		BSR 2–7: <i>Reserved for Future Use</i>	BA+2:	(bit 2–7): 0

NOTE:

1. BA = The beginning location of a Block Address (i.e., 008000h is block 1's (64-KB block) beginning location in word mode).

4.2.4 CFI QUERY IDENTIFICATION STRING

The Identification String provides verification that the component supports the Common Flash Interface specification. It also indicates the specification version and supported vendor-specified command set(s).

Table 9. CFI Identification

Offset	Length	Description	Add.	Hex Code	Value
10h	3	Query-unique ASCII string "QRY"	10: 11: 12:	--51 --52 --59	"Q" "R" "Y"
13h	2	Primary vendor command set and control interface ID code. 16-bit ID code for vendor-specified algorithms	13: 14:	--01 --00	
15h	2	Extended Query Table primary algorithm address	15: 16:	--31 --00	
17h	2	Alternate vendor command set and control interface ID code. 0000h means no second vendor-specified algorithm exists	17: 18:	--00 --00	
19h	2	Secondary algorithm Extended Query Table address. 0000h means none exists	19: 1A:	--00 --00	

4.2.5 SYSTEM INTERFACE INFORMATION

The following device information can optimize system interface software.

Table 10. System Interface Information

Offset	Length	Description	Add.	Hex Code	Value
1Bh	1	V _{CC} logic supply minimum program/erase voltage bits 0–3 BCD 100 mV bits 4–7 BCD volts	1B:	--45	4.5 V
1Ch	1	V _{CC} logic supply maximum program/erase voltage bits 0–3 BCD 100 mV bits 4–7 BCD volts	1C:	--55	5.5 V
1Dh	1	V _{PP} [programming] supply minimum program/erase voltage bits 0–3 BCD 100 mV bits 4–7 HEX volts	1D:	--00	0.0 V
1Eh	1	V _{PP} [programming] supply maximum program/erase voltage bits 0–3 BCD 100 mV bits 4–7 HEX volts	1E:	--00	0.0 V
1Fh	1	"n" such that typical single word program time-out = 2 ⁿ μs	1F:	--07	128 μs
20h	1	"n" such that typical max. buffer write time-out = 2 ⁿ μs	20:	--07	128 μs
21h	1	"n" such that typical block erase time-out = 2 ⁿ ms	21:	--0A	1 s
22h	1	"n" such that typical full chip erase time-out = 2 ⁿ ms	22:	--00	NA
23h	1	"n" such that maximum word program time-out = 2 ⁿ times typical	23:	--04	192 μs
24h	1	"n" such that maximum buffer write time-out = 2 ⁿ times typical	24:	--04	192 μs
25h	1	"n" such that maximum block erase time-out = 2 ⁿ times typical	25:	--04	16 s
26h	1	"n" such that maximum chip erase time-out = 2 ⁿ times typical	26:	--00	NA

4.2.6 DEVICE GEOMETRY DEFINITION

This field provides critical details of the flash device geometry.

Table 11. Device Geometry Definition

Offset	Length	Description	Code See table below		
27h	1	"n" such that device size = 2^n in number of bytes	27:		
28h	2	Flash device interface: <u>x8 async</u> <u>x16 async</u> <u>x8/x16 async</u> 28:00,29:00 28:01,29:00 28:02,29:00	28:	--02	x8/ x16
2Ah	2	"n" such that maximum number of bytes in write buffer = 2^n	2A:	--05	32
			2B:	--00	
2Ch	1	Number of erase block regions within device: 1. x = 0 means no erase blocking; the device erases in "bulk" 2. x specifies the number of device or partition regions with one or more contiguous same-size erase blocks 3. Symmetrically blocked partitions have one blocking region 4. Partition size = (total blocks) x (individual block size)	2C:	--01	1
2Dh	4	Erase Block Region 1 Information bits 0–15 = y, y+1 = number of identical-size erase blocks bits 16–31 = z, region erase block(s) size are z x 256 bytes	2D:		
			2E:		
			2F:		
			30:		

Device Geometry Definition

Address	32 Mbit	64 Mbit	128 Mbit (Info only)
27:	--16	--17	--18
28:	--02	--02	--02
29:	--00	--00	--00
2A:	--05	--05	--05
2B:	--00	--00	--00
2C:	--01	--01	--01
2D:	--1F	--3F	--7F
2E:	--00	--00	--00
2F:	--00	--00	--00
30:	--02	--02	--02

4.2.7 PRIMARY-VENDOR SPECIFIC EXTENDED QUERY TABLE

Certain flash features and commands are optional. The *Primary Vendor-Specific Extended Query* table specifies this and other similar information.

Table 12. Primary Vendor-Specific Extended Query

Offset ⁽¹⁾ P = 31h	Length	Description (Optional Flash Features and Commands)	Add.	Hex Code	Value
(P+0)h	3	Primary extended query table	31:	--50	"P"
(P+1)h		Unique ASCII string "PRI"	32:	--52	"R"
(P+2)h			33:	--49	"I"
(P+3)h	1	Major version number, ASCII	34:	--31	"1"
(P+4)h	1	Minor version number, ASCII	35:	--31	"1"
(P+5)h	4	Optional feature and command support (1=yes, 0=no) <i>bits 9–31 are reserved; undefined bits are "0." If bit 31 is "1" then another 31 bit field of optional features follows at the end of the bit-30 field.</i>	36:	--0A	
(P+6)h			37:	--00	
(P+7)h			38:	--00	
(P+8)h			39:	--00	
		bit 0 Chip erase supported		bit 0 = 0	No
	bit 1 Suspend erase supported		bit 1 = 1	Yes	
	bit 2 Suspend program supported		bit 2 = 0	No	
	bit 3 Legacy lock/unlock supported		bit 3 = 1	Yes	
	bit 4 Queued erase supported		bit 4 = 0	No	
(P+9)h	1	Supported functions after suspend: read Array, Status, Query Other supported operations are: <i>bits 1–7 reserved; undefined bits are "0"</i>	3A:	--01	
		bit 0 Program supported after erase suspend		bit 0 = 1	Yes
(P+A)h	2	Block status register mask <i>bits 2–15 are Reserved; undefined bits are "0"</i>	3B:	--01	
(P+B)h		bit 0 Block Lock-Bit Status register active	3C:	--00	
		bit 1 Block Lock-Down Bit Status active		bit 0 = 1	Yes
				bit 1 = 0	No
(P+C)h	1	V _{CC} logic supply highest performance program/erase voltage bits 0–3 BCD value in 100 mV bits 4–7 BCD value in volts	3D:	--50	5.0 V
(P+D)h	1	V _{PP} optimum program/erase supply voltage bits 0–3 BCD value in 100 mV bits 4–7 HEX value in volts	3E:	--00	0.0 V
(P+E)h		<i>Reserved for Future Use</i>	3F:		

NOTE:

- The variable P is a pointer which is defined at CFI offset 15h.

4.3 Read Identifier Codes Command

The identifier code operation is initiated by writing the Read Identifier Codes command. Following the command write, read cycles from addresses shown in Figure 6 retrieve the manufacturer, device, block lock configuration and master lock configuration codes (see Table 13 for identifier code values). To terminate the operation, write another valid command. Like the Read Array command, the Read Identifier Codes command functions independently of the V_{PEN} voltage and RP# can be V_{IH} or V_{HH} . This command is valid only when the WSM is off or the device is suspended. Following the Read Identifier Codes command, the following information can be read:

Table 13. Identifier Codes⁽¹⁾

Code		Address ⁽¹⁾	Data
Manufacture Code		00000	(00) 89
Device Code	32-Mbit	00001	(00) 14
	64-Mbit	00001	(00) 15
Block Lock Configuration		X0002 ⁽²⁾	
• Block Is Unlocked			DQ ₀ = 0
• Block Is Locked			DQ ₀ = 1
• Reserved for Future Use			DQ ₁₋₇
Master Lock Configuration		00003	
• Device Is Unlocked			DQ ₀ = 0
• Device Is Locked			DQ ₀ = 1
• Reserved for Future Use			DQ ₁₋₇

NOTE:

- A_0 is not used in either x8 or x16 modes when obtaining the identifier codes. The lowest order address line is A_1 . Data is always presented on the low byte in x16 mode (upper byte contains 00h).
- X selects the specific block's lock configuration code. See Figure 6 for the device identifier code memory map.

4.4 Read Status Register Command

The status register may be read to determine when a block erase, program, or lock-bit configuration is complete and whether the operation completed successfully. It may be read at any time by writing the Read Status Register command. After writing this command, all subsequent read operations output data from the status register until another valid command is written. The status register

contents are latched on the falling edge of OE# or the first edge of CE₀, CE₁, or CE₂ that enables the device (see Table 2, *Chip Enable Truth Table*). OE# must toggle to V_{IH} or the device must be disabled (see Table 2, *Chip Enable Truth Table*) before further reads to update the status register latch. The Read Status Register command functions independently of the V_{PEN} voltage. RP# can be V_{IH} or V_{HH} .

During a program, block erase, set lock-bit, or clear lock-bit command sequence, only SR.7 is valid until the WSM completes or suspends the operation. Device I/O pins DQ₀–DQ₆ and DQ₈–DQ₁₅ are placed in a high-impedance state. When the operation completes or suspends (check status register bit 7), all contents of the status register are valid when read.

4.5 Clear Status Register Command

Status register bits SR.5, SR.4, SR.3, and SR.1 are set to "1"s by the WSM and can only be reset by the Clear Status Register command. These bits indicate various failure conditions (see Table 16). By allowing system software to reset these bits, several operations (such as cumulatively erasing or locking multiple blocks or writing several bytes in sequence) may be performed. The status register may be polled to determine if an error occurred during the sequence.

To clear the status register, the Clear Status Register command (50H) is written. It functions independently of the applied V_{PEN} voltage. RP# can be V_{IH} or V_{HH} . The Clear Status Register command is only valid when the WSM is off or the device is suspended.

4.6 Block Erase Command

Erase is executed one block at a time and initiated by a two-cycle command. A block erase setup is first written, followed by an block erase confirm. This command sequence requires an appropriate address within the block to be erased (erase changes all block data to FFH). Block preconditioning, erase, and verify are handled internally by the WSM (invisible to the system). After the two-cycle block erase sequence is written, the device automatically outputs status register data when read (see Figure 9). The CPU can detect block erase completion by analyzing the output of

the STS pin or status register bit SR.7. Toggle OE#, CE₀, CE₁, or CE₂ to update the status register.

When the block erase is complete, status register bit SR.5 should be checked. If a block erase error is detected, the status register should be cleared before system software attempts corrective actions. The CUI remains in read status register mode until a new command is issued.

This two-step command sequence of set-up followed by execution ensures that block contents are not accidentally erased. An invalid Block Erase command sequence will result in both status register bits SR.4 and SR.5 being set to "1." Also, reliable block erasure can only occur when V_{CC} is valid and V_{PEN} = V_{PENH}. If block erase is attempted while V_{PEN} ≤ V_{PENLK}, SR.3 and SR.5 will be set to "1." Successful block erase requires that the corresponding block lock-bit be cleared or, if set, that RP# = V_{HH}. If block erase is attempted when the corresponding block lock-bit is set and RP# = V_{IH}, SR.1 and SR.5 will be set to "1." Block erase operations with V_{IH} < RP# < V_{HH} produce spurious results and should not be attempted.

4.7 Block Erase Suspend Command

The Block Erase Suspend command allows block-erase interruption to read or program data in another block of memory. Once the block erase process starts, writing the Block Erase Suspend command requests that the WSM suspend the block erase sequence at a predetermined point in the algorithm. The device outputs status register data when read after the Block Erase Suspend command is written. Polling status register bit SR.7 then SR.6 can determine when the block erase operation has been suspended (both will be set to "1"). In default mode, STS will also transition to V_{OH}. Specification t_{WHRH} defines the block erase suspend latency.

At this point, a Read Array command can be written to read data from blocks other than that which is suspended. A program command sequence can also be issued during erase suspend to program data in other blocks. During a program operation with block erase suspended, status register bit SR.7 will return to "0" and the STS output (in default mode) will transition to V_{OL}.

The only other valid commands while block erase is suspended are Read Query, Read Status Register, Clear Status Register, Configure, and Block Erase Resume. After a Block Erase Resume command is written to the flash memory, the WSM will continue the block erase process. Status register bits SR.6 and SR.7 will automatically clear and STS (in default mode) will return to V_{OL}. After the Erase Resume command is written, the device automatically outputs status register data when read (see Figure 10). V_{PEN} must remain at V_{PENH} (the same V_{PEN} level used for block erase) while block erase is suspended. RP# must also remain at V_{IH} or V_{HH} (the same RP# level used for block erase). Block erase cannot resume until program operations initiated during block erase suspend have completed.

4.8 Write to Buffer Command

To program the flash device, a Write to Buffer command sequence is initiated. A variable number of bytes, up to the buffer size, can be loaded into the buffer and written to the flash device. First, the Write to Buffer setup command is issued along with the Block Address (see Figure 7, *Write to Buffer Flowchart*). At this point, the eXtended Status Register (XSR, see Table 17) information is loaded and XSR.7 reverts to "buffer available" status. If XSR.7 = 0, the write buffer is not available. To retry, continue monitoring XSR.7 by issuing the Write to Buffer setup command with the Block Address until XSR.7 = 1. When XSR.7 transitions to a "1," the buffer is ready for loading.

Now a word/byte count is given to the part with the Block Address. On the next write, a device start address is given along with the write buffer data. Subsequent writes provide additional device addresses and data, depending on the count. All subsequent addresses must lie within the start address plus the count.

Internally, this device programs many flash cells in parallel. Because of this parallel programming, maximum programming performance and lower power are obtained by aligning the start address at the beginning of a write buffer boundary (i.e., A₄–A₀ of the start address = 0).

After the final buffer data is given, a Write Confirm command is issued. This initiates the WSM (Write State Machine) to begin copying the buffer data to the flash array. If a command other than Write

Confirm is written to the device, an “Invalid Command/Sequence” error will be generated and status register bits SR.5 and SR.4 will be set to a “1.” For additional buffer writes, issue another Write to Buffer setup command and check XSR.7.

If an error occurs while writing, the device will stop writing, and status register bit SR.4 will be set to a “1” to indicate a program failure. The internal WSM verify only detects errors for “1”s that do not successfully program to “0”s. If a program error is detected, the status register should be cleared. Any time SR.4 and/or SR.5 is set (e.g., a media failure occurs during a program or an erase), the device will not accept any more Write to Buffer commands. Additionally, if the user attempts to program past an erase block boundary with a Write to Buffer command, the device will abort the write to buffer operation. This will generate an “Invalid Command/Sequence” error and status register bits SR.5 and SR.4 will be set to a “1.”

Reliable buffered writes can only occur when $V_{PEN} = V_{PENH}$. If a buffered write is attempted while $V_{PEN} \leq V_{PENLK}$, status register bits SR.4 and SR.3 will be set to “1.” Buffered write attempts with invalid V_{CC} and V_{PEN} voltages produce spurious results and should not be attempted. Finally, successful programming requires that the corresponding Block Lock-Bit be reset or, if set, that $RP\# = V_{HH}$. If a buffered write is attempted when the corresponding Block Lock-Bit is set and $RP\# = V_{IH}$, SR.1 and SR.4 will be set to “1.” Buffered write operations with $V_{IH} < RP\# < V_{HH}$ produce spurious results and should not be attempted.

4.9 Byte/Word Program Commands

Byte/Word program is executed by a two-cycle command sequence. Byte/Word program setup (standard 40H or alternate 10H) is written followed by a second write that specifies the address and data (latched on the rising edge of WE#). The WSM then takes over, controlling the program and program verify algorithms internally. After the program sequence is written, the device automatically outputs status register data when read (see Figure 8). The CPU can detect the completion of the program event by analyzing the STS pin or status register bit SR.7.

When program is complete, status register bit SR.4 should be checked. If a program error is detected, the status register should be cleared. The internal WSM verify only detects errors for “1”s that do not successfully program to “0”s. The CUI remains in read status register mode until it receives another command.

Reliable byte/word programs can only occur when V_{CC} and V_{PEN} are valid. If a byte/word program is attempted while $V_{PEN} \leq V_{PENLK}$, status register bits SR.4 and SR.3 will be set to “1.” Successful byte/word programs require that the corresponding block lock-bit be cleared or, if set, that $RP\# = V_{HH}$. If a byte/word program is attempted when the corresponding block lock-bit is set and $RP\# = V_{IH}$, SR.1 and SR.4 will be set to “1.” Byte/word program operations with $V_{IH} < RP\# < V_{HH}$ produce spurious results and should not be attempted.

4.10 Configuration Command

The Status (STS) pin can be configured to different states using the Configuration command. Once the STS pin has been configured, it remains in that configuration until another configuration command is issued or $RP\#$ is asserted low. Initially, the STS pin defaults to RY/BY# operation where RY/BY# low indicates that the state machine is busy. RY/BY# high indicates that the state machine is ready for a new operation or suspended. Table 15 displays the possible STS configurations.

To reconfigure the Status (STS) pin to other modes, the Configuration command is given followed by the desired configuration code. The three alternate configurations are all pulse mode for use as a system interrupt as described below. For these configurations, bit 0 controls Erase Complete interrupt pulse, and bit 1 controls Program Complete interrupt pulse. Supplying the 00h configuration code with the Configuration command resets the STS pin to the default RY/BY# level mode. The possible configurations and their usage are described in Table 15. The Configuration command may only be given when the device is not busy or suspended. Check SR.7 for device status. An invalid configuration code will result in both status register bits SR.4 and SR.5 being set to “1.” When configured in one of the pulse modes, the STS pin pulses low with a typical pulse width of 250 ns.

4.11 Set Block and Master Lock-Bit Commands

A flexible block locking and unlocking scheme is enabled via a combination of block lock-bits and a master lock-bit. The block lock-bits gate program and erase operations while the master lock-bit gates block-lock bit modification. With the master lock-bit not set, individual block lock-bits can be set using the Set Block Lock-Bit command. The Set Master Lock-Bit command, in conjunction with $RP\# = V_{HH}$, sets the master lock-bit. After the master lock-bit is set, subsequent setting of block lock-bits requires both the Set Block Lock-Bit command and V_{HH} on the $RP\#$ pin. These commands are invalid while the WSM is running or the device is suspended. See Table 14 for a summary of hardware and software write protection options.

Set block lock-bit and master lock-bit commands are executed by a two-cycle sequence. The set block or master lock-bit setup along with appropriate block or device address is written followed by either the set block lock-bit confirm (and an address within the block to be locked) or the set master lock-bit confirm (and any device address). The WSM then controls the set lock-bit algorithm. After the sequence is written, the device automatically outputs status register data when read (see Figure 11). The CPU can detect the completion of the set lock-bit event by analyzing the STS pin output or status register bit SR.7.

When the set lock-bit operation is complete, status register bit SR.4 should be checked. If an error is detected, the status register should be cleared. The CUI will remain in read status register mode until a new command is issued.

This two-step sequence of set-up followed by execution ensures that lock-bits are not accidentally set. An invalid Set Block or Master Lock-Bit command will result in status register bits SR.4 and SR.5 being set to "1." Also, reliable operations occur only when V_{CC} and V_{PEN} are valid. With $V_{PEN} \leq V_{PENLK}$, lock-bit contents are protected against alteration.

A successful set block lock-bit operation requires that the master lock-bit be zero or, if the master lock-bit is set, that $RP\# = V_{HH}$. If it is attempted with the master lock-bit set and $RP\# = V_{IH}$, SR.1 and SR.4 will be set to "1" and the operation will fail. Set block lock-bit operations while $V_{IH} < RP\# < V_{HH}$ produce spurious results and should not be attempted. A successful set master lock-bit operation requires that $RP\# = V_{HH}$. If it is attempted with $RP\# = V_{IH}$, SR.1 and SR.4 will be set to "1" and the operation will fail. Set master lock-bit operations with $V_{IH} < RP\# < V_{HH}$ produce spurious results and should not be attempted.

4.12 Clear Block Lock-Bits Command

All set block lock-bits are cleared in parallel via the Clear Block Lock-Bits command. With the master lock-bit not set, block lock-bits can be cleared using only the Clear Block Lock-Bits command. If the master lock-bit is set, clearing block lock-bits requires both the Clear Block Lock-Bits command and V_{HH} on the $RP\#$ pin. This command is invalid while the WSM is running or the device is suspended. See Table 14 for a summary of hardware and software write protection options.

Clear block lock-bits command is executed by a two-cycle sequence. A clear block lock-bits setup is first written. The device automatically outputs status register data when read (see Figure 12). The CPU can detect completion of the clear block lock-bits event by analyzing the STS pin output or status register bit SR.7.

When the operation is complete, status register bit SR.5 should be checked. If a clear block lock-bit error is detected, the status register should be cleared. The CUI will remain in read status register mode until another command is issued.

This two-step sequence of set-up followed by execution ensures that block lock-bits are not accidentally cleared. An invalid Clear Block Lock-Bits command sequence will result in status register bits SR.4 and SR.5 being set to "1." Also, a reliable clear block lock-bits operation can only occur when V_{CC} and V_{PEN} are valid. If a clear block lock-bits operation is attempted while $V_{PEN} \leq V_{PENLK}$, SR.3 and SR.5 will be set to "1." A

successful clear block lock-bits operation requires that the master lock-bit is not set or, if the master lock-bit is set, that $RP\# = V_{HH}$. If it is attempted with the master lock-bit set and $RP\# = V_{IH}$, SR.1 and SR.5 will be set to "1" and the operation will fail. A clear block lock-bits operation with $V_{IH} < RP\# < V_{HH}$ produce spurious results and should not be attempted.

If a clear block lock-bits operation is aborted due to V_{PEN} or V_{CC} transitioning out of valid range or $RP\#$ active transition, block lock-bit values are left in an undetermined state. A repeat of clear block lock-bits is required to initialize block lock-bit contents to known values. Once the master lock-bit is set, it cannot be cleared.

Table 14. Write Protection Alternatives

Operation	Master Lock-Bit	Block Lock-Bit	RP#	Effect
Block Erase or Program	X	0	V_{IH} or V_{HH}	Block Erase and Program Enabled
		1	V_{IH}	Block is Locked. Block Erase and Program Disabled
			V_{HH}	Block Lock-Bit Override. Block Erase and Program Enabled
Set or Clear Block Lock-Bit	0	X	V_{IH} or V_{HH}	Set or Clear Block Lock-Bit Enabled
	1	X	V_{IH}	Master Lock-Bit Is Set. Set or Clear Block Lock-Bit Disabled
			V_{HH}	Master Lock-Bit Override. Set or Clear Block Lock-Bit Enabled
Set Master Lock-Bit	X	X	V_{IH}	Set Master Lock-Bit Disabled
			V_{HH}	Set Master Lock-Bit Enabled

Table 15. Configuration Coding Definitions

Reserved	Pulse On Program Complete ⁽¹⁾	Pulse On Erase Complete ⁽¹⁾
bits 7–2	bit 1	bit 0
<p>DQ7–DQ2 = Reserved</p> <p>DQ1–DQ0 = STS Pin Configuration Codes</p> <p>00 = default, level mode RY/BY# (device ready) indication</p> <p>01 = pulse on Erase complete</p> <p>10 = pulse on Program complete</p> <p>11 = pulse on Erase or Program Complete</p> <p>Configuration Codes 01b, 10b, and 11b are all pulse mode such that the STS pin pulses low then high when the operation indicated by the given configuration is completed.</p> <p>Configuration Command Sequences for STS pin configuration (masking bits DQ7–DQ2 to 00h) are as follows:</p> <p>Default RY/BY# level mode: B8h, 00h</p> <p>ER INT (Erase Interrupt): B8h, 01h</p> <p style="padding-left: 20px;">Pulse-on-Erase Complete</p> <p>PR INT (Program Interrupt): B8h, 02h</p> <p style="padding-left: 20px;">Pulse-on-Program Complete</p> <p>ER/PR INT (Erase or Program Interrupt): B8h, 03h</p> <p style="padding-left: 20px;">Pulse-on-Erase or Program Complete</p>	<p>DQ7–DQ2 are reserved for future use.</p> <p>default (DQ1–DQ0 = 00) RY/BY#, level mode — used to control HOLD to a memory controller to prevent accessing a flash memory subsystem while any flash device’s WSM is busy.</p> <p>configuration 01 ER INT, pulse mode — used to generate a system interrupt pulse when any flash device in an array has completed a Block Erase or sequence of Queued Block Erases. Helpful for reformatting blocks after file system free space reclamation or “cleanup”</p> <p>configuration 10 PR INT, pulse mode — used to generate a system interrupt pulse when any flash device in an array has complete a Program operation. Provides highest performance for servicing continuous buffer write operations.</p> <p>configuration 11 ER/PR INT, pulse mode — used to generate system interrupts to trigger servicing of flash arrays when either erase or program operations are completed when a common interrupt service routine is desired.</p>	

NOTE:

1. When the device is configured in one of the pulse modes, the STS pin pulses low with a typical pulse width of 250 ns.

Table 16. Status Register Definitions

WSMS	ESS	ECLBS	PSLBS	VPENS	R	DPS	R
bit 7	bit 6	bit 5	bit 4	bit 3	bit 2	bit 1	bit 0
High Z When Busy?	Status Register Bits						NOTES:
No	SR.7 = WRITE STATE MACHINE STATUS 1 = Ready 0 = Busy						Check STS or SR.7 to determine block erase, program, or lock-bit configuration completion. SR.6–SR.0 are not driven while SR.7 = “0.”
Yes	SR.6 = ERASE SUSPEND STATUS 1 = Block Erase Suspended 0 = Block Erase in Progress/Completed						If both SR.5 and SR.4 are “1”s after a block erase or lock-bit configuration attempt, an improper command sequence was entered.
Yes	SR.5 = ERASE AND CLEAR LOCK-BITS STATUS 1 = Error in Block Erasure or Clear Lock-Bits 0 = Successful Block Erase or Clear Lock-Bits						SR.3 does not provide a continuous programming voltage level indication. The WSM interrogates and indicates the programming voltage level only after Block Erase, Program, Set Block/Master Lock-Bit, or Clear Block Lock-Bits command sequences.
Yes	SR.4 = PROGRAM AND SET LOCK-BIT STATUS 1 = Error in Programming or Set Master/Block Lock-Bit 0 = Successful Programming or Set Master/Block Lock Bit						SR.1 does not provide a continuous indication of master and block lock-bit values. The WSM interrogates the master lock-bit, block lock-bit, and RP# only after Block Erase, Program, or Lock-Bit configuration command sequences. It informs the system, depending on the attempted operation, if the block lock-bit is set, master lock-bit is set, and/or RP# is not V_{HH} . Read the block lock and master lock configuration codes using the Read Identifier Codes command to determine master and block lock-bit status.
Yes	SR.3 = PROGRAMMING VOLTAGE STATUS 1 = Low Programming Voltage Detected, Operation Aborted 0 = Programming Voltage OK						
Yes	SR.2 = RESERVED FOR FUTURE ENHANCEMENTS						
Yes	SR.1 = DEVICE PROTECT STATUS 1 = Master Lock-Bit, Block Lock-Bit and/or RP# Lock Detected, Operation Abort 0 = Unlock						
Yes	SR.0 = RESERVED FOR FUTURE ENHANCEMENTS						SR.2 and SR.0 are reserved for future use and should be masked when polling the status register.

Table 17. eXtended Status Register Definitions

WBS	Reserved	
bit 7	bits 6–0	
High Z When Busy?	Status Register Bits	NOTES:
No	XSR.7 = WRITE BUFFER STATUS 1 = Write buffer available 0 = Write buffer not available	After a Buffer-Write command, XSR.7 = 1 indicates that a Write Buffer is available.
Yes	XSR.6–XSR.0 = RESERVED FOR FUTURE ENHANCEMENTS	SR.6–SR.0 are reserved for future use and should be masked when polling the status register.

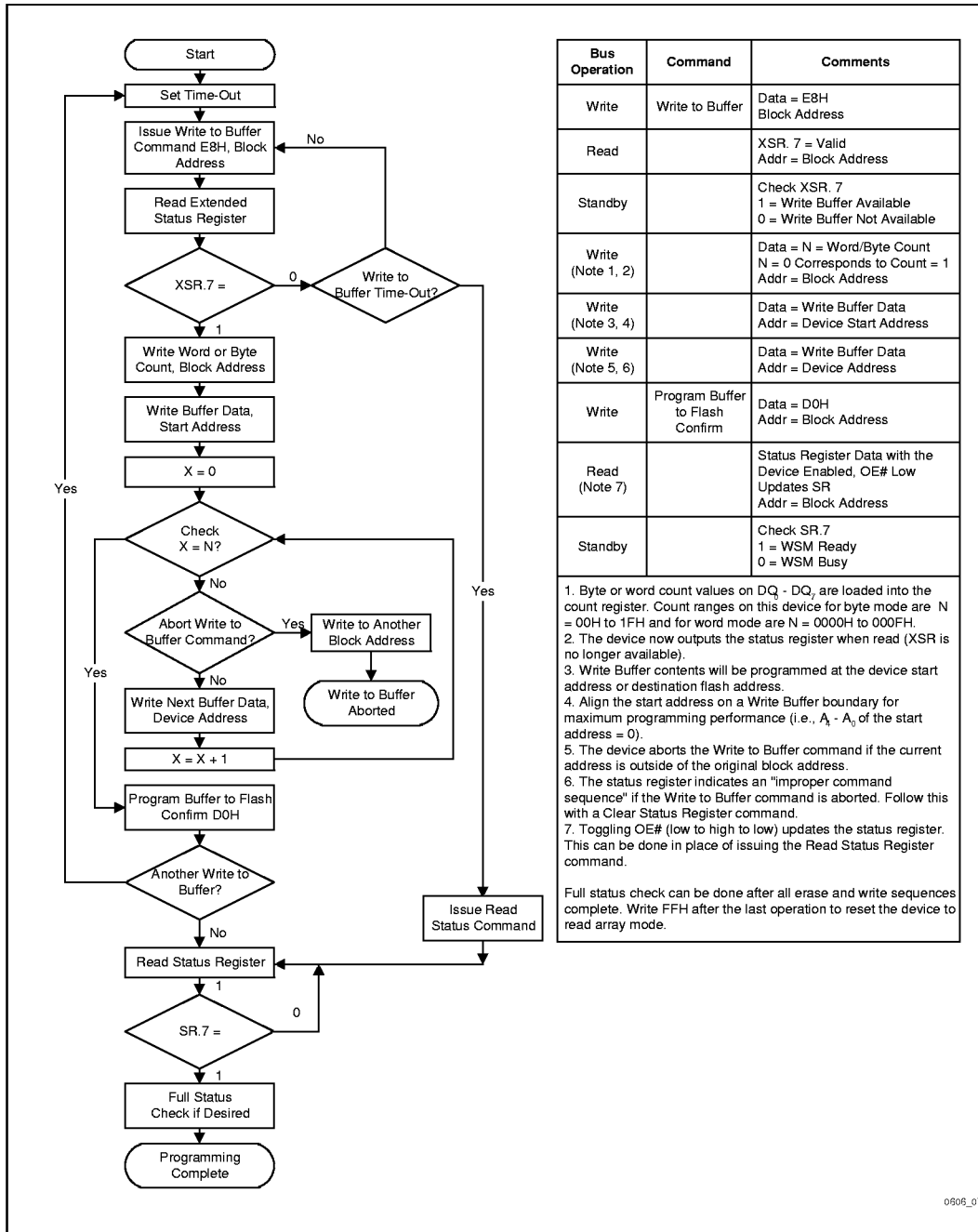

Figure 7. Write to Buffer Flowchart

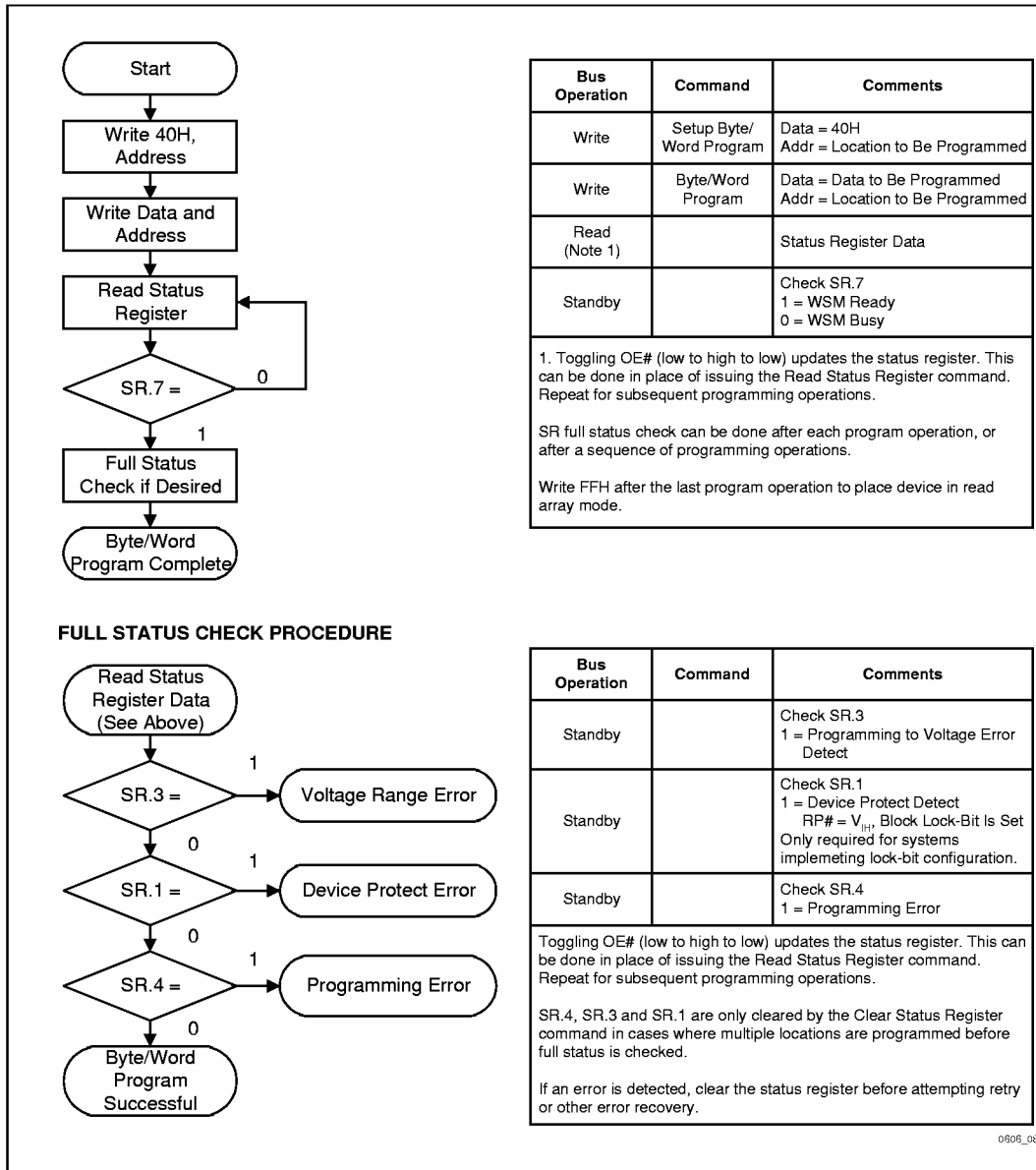

Figure 8. Byte/Word Program Flowchart

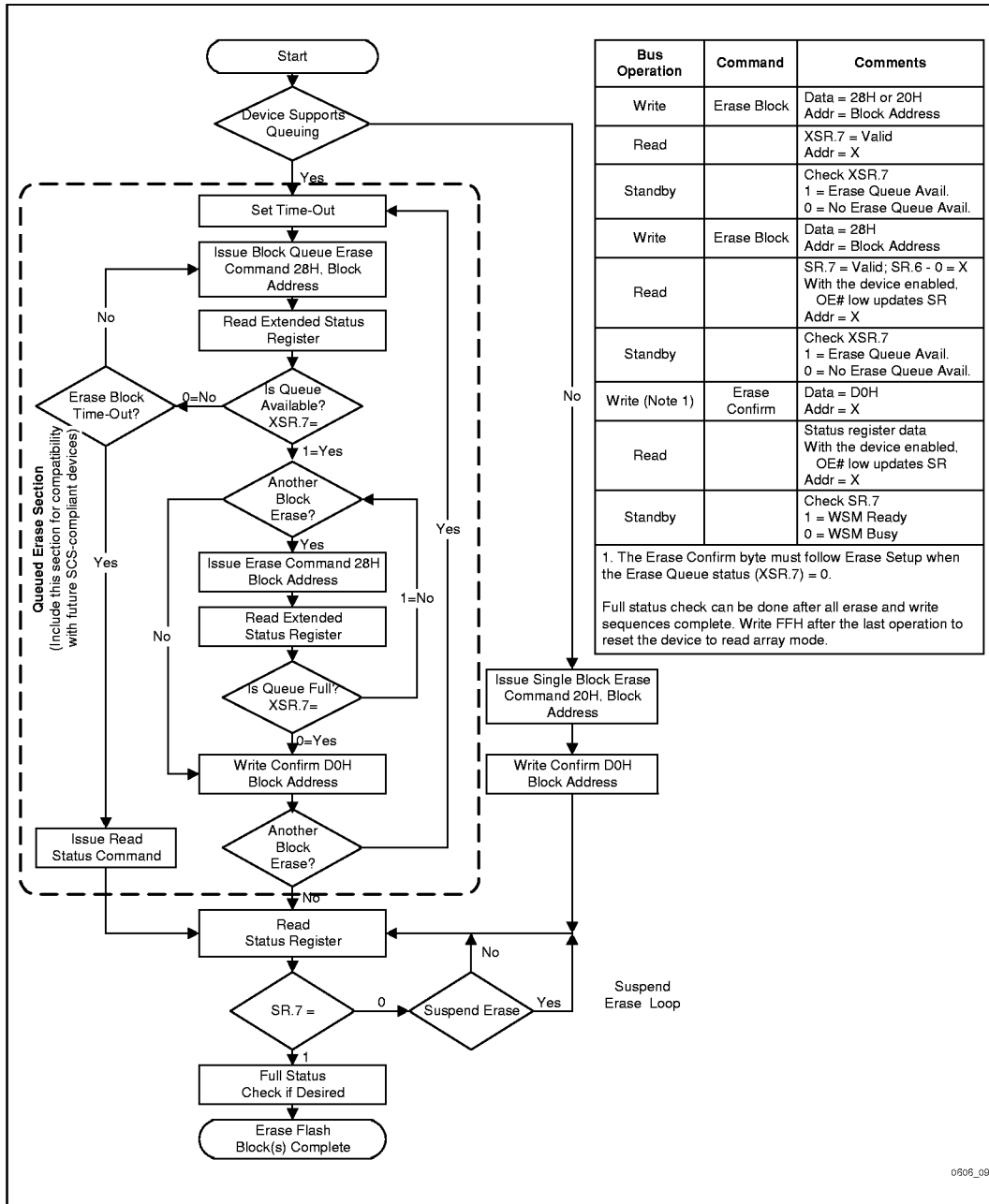

Figure 9. Block Erase Flowchart

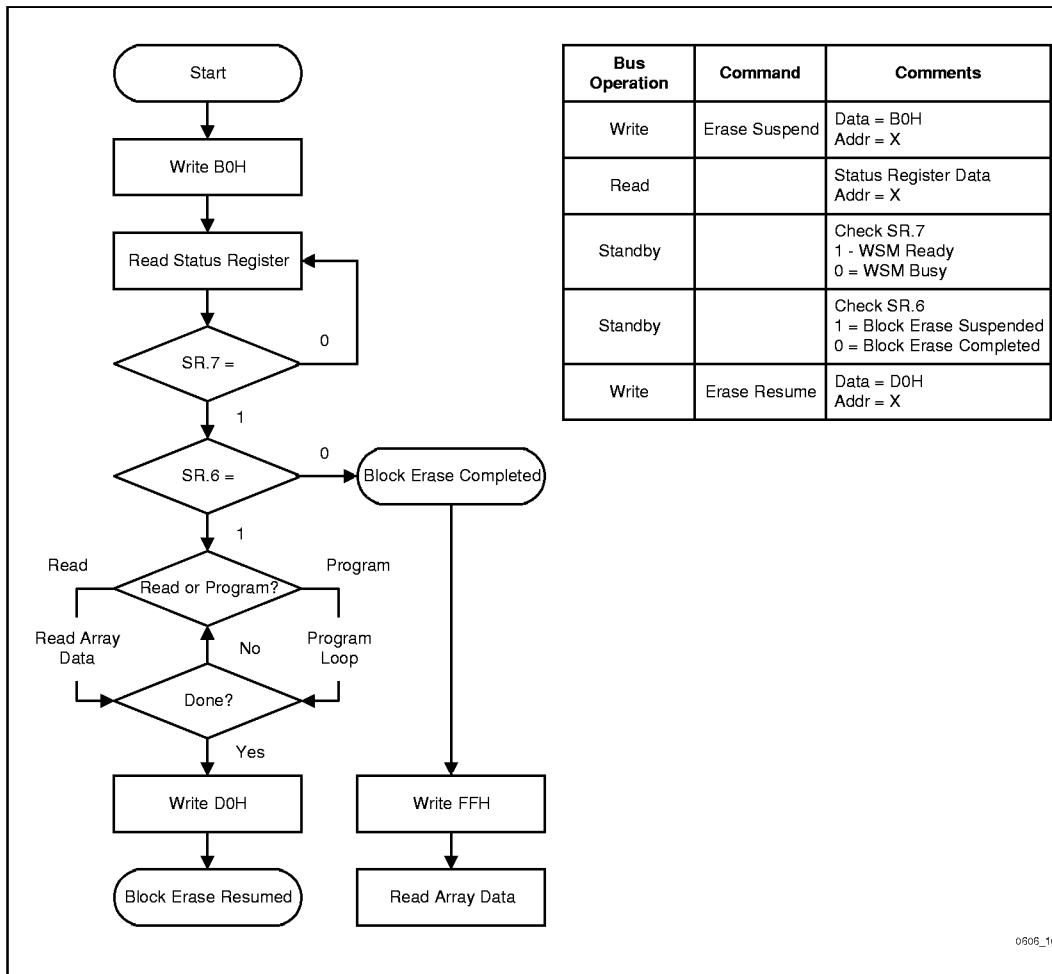

Figure 10. Block Erase Suspend/Resume Flowchart

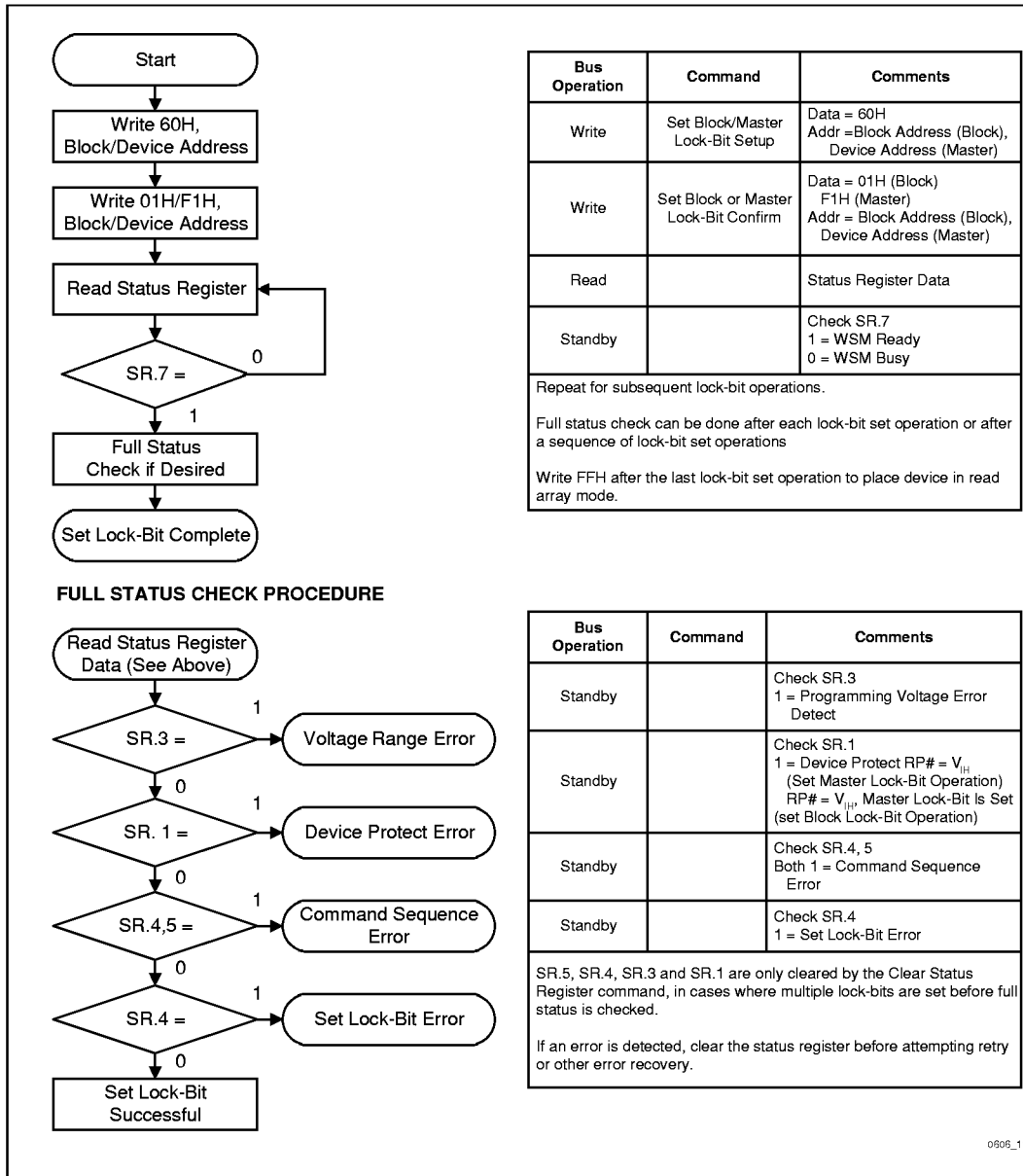

Figure 11. Set Block Lock-Bit Flowchart

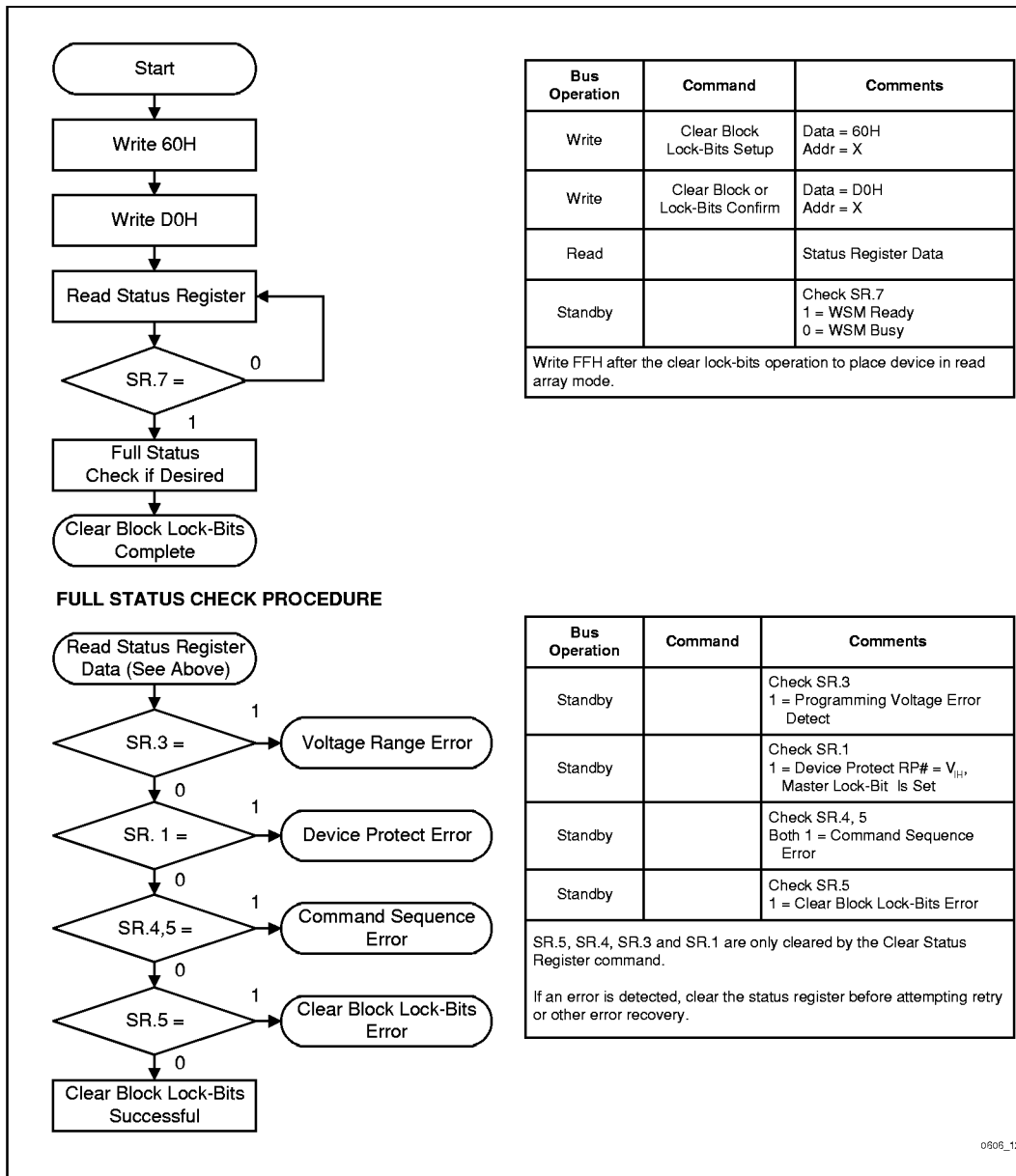

Figure 12. Clear Block Lock-Bit Flowchart

5.0 DESIGN CONSIDERATIONS

5.1 Three-Line Output Control

The device will often be used in large memory arrays. Intel provides five control inputs (CE₀, CE₁, CE₂, OE#, and RP#) to accommodate multiple memory connections. This control provides for:

- Lowest possible memory power dissipation.
- Complete assurance that data bus contention will not occur.

To use these control inputs efficiently, an address decoder should enable the device (see Table 2, *Chip Enable Truth Table*) while OE# should be connected to all memory devices and the system's READ# control line. This assures that only selected memory devices have active outputs while deselected memory devices are in standby mode. RP# should be connected to the system POWERGOOD signal to prevent unintended writes during system power transitions. POWERGOOD should also toggle during system reset.

5.2 STS and Block Erase, Program, and Lock-Bit Configuration Polling

STS is an open drain output that should be connected to V_{CCQ} by a pull-up resistor to provide a hardware method of detecting block erase, program, and lock-bit configuration completion. In default mode, it transitions low after block erase, program, or lock-bit configuration commands and returns to High Z when the WSM has finished executing the internal algorithm. For alternate configurations of the STS pin, see the Configuration command.

STS can be connected to an interrupt input of the system CPU or controller. It is active at all times. STS, in default mode, is also High Z when the device is in block erase suspend (with programming inactive) or in reset/power-down mode.

5.3 Power Supply Decoupling

Flash memory power switching characteristics require careful device decoupling. System designers are interested in three supply current issues; standby current levels, active current levels and transient peaks produced by falling and rising edges of CE₀, CE₁, CE₂, and OE#. Transient current magnitudes depend on the device outputs' capacitive and inductive loading. Two-line control and proper decoupling capacitor selection will suppress transient voltage peaks. Since Intel StrataFlash memory devices draw their power from three V_{CC} pins (these devices do not include a V_{PP} pin), it is recommended that systems without separate power and ground planes attach a 0.1 μF ceramic capacitor between each of the device's three V_{CC} pins (this includes V_{CCQ}) and ground. These high-frequency, low-inductance capacitors should be placed as close as possible to package leads on each Intel StrataFlash memory device. Each device should have a 0.1 μF ceramic capacitor connected between its V_{CC} and GND. These high-frequency, low inductance capacitors should be placed as close as possible to package leads. Additionally, for every eight devices, a 4.7 μF electrolytic capacitor should be placed between V_{CC} and GND at the array's power supply connection. The bulk capacitor will overcome voltage slumps caused by PC board trace inductance.

5.4 Input Signal Transitions – Reducing Overshoots and Undershoots When Using Buffers/Transceivers

As faster, high-drive devices such as transceivers or buffers drive input signals to flash memory devices, overshoots and undershoots can sometimes cause input signals to exceed flash memory specifications (see Section 6.1, *Absolute Maximum Ratings*). Many buffer/transceiver vendors now carry bus-interface devices with internal output-damping resistors or reduced-drive outputs. Internal output-damping resistors diminish the nominal output drive currents, while still leaving sufficient drive capability for most applications. These internal output-

damping resistors help reduce unnecessary overshoots and undershoots. Transceivers or buffers with balanced- or light-drive outputs also reduce overshoots and undershoots by diminishing output-drive currents. When selecting a buffer/transceiver interface design to flash, devices with internal output-damping resistors or reduced-drive outputs should be considered to minimize overshoots and undershoots. For additional information, please refer to *AP-647, 5 Volt Intel® StrataFlash™ Memory Design Guide* (order 292205).

5.5 V_{CC}, V_{PEN}, RP# Transitions

Block erase, program, and lock-bit configuration are not guaranteed if V_{PEN} or V_{CC} falls outside of the specified operating ranges, or RP# ≠ V_{IH} or V_{HH}. If RP# transitions to V_{IL} during block erase, program, or lock-bit configuration, STS (in default mode) will remain low for a maximum time of t_{PLPH} + t_{PHRH} until the reset operation is complete. Then, the operation will abort and the device will enter reset/power-down mode. The aborted operation may leave data partially corrupted after programming, or partially altered after an erase or lock-bit configuration. Therefore, block erase and lock-bit configuration commands must be repeated after normal operation is restored. Device power-off or RP# = V_{IL} clears the status register.

The CUI latches commands issued by system software and is not altered by V_{PEN}, CE₀, CE₁, or CE₂ transitions, or WSM actions. Its state is read array mode upon power-up, after exit from reset/power-down mode, or after V_{CC} transitions below V_{LKO}. V_{CC} must be kept at or above V_{PEN} during V_{CC} transitions.

After block erase, program, or lock-bit configuration, even after V_{PEN} transitions down to V_{PENLK}, the CUI must be placed in read array mode via the Read Array command if subsequent access to the memory array is desired. V_{PEN} must be kept at or below V_{CC} during V_{PEN} transitions.

5.6 Power-Up/Down Protection

The device is designed to offer protection against accidental block erasure, programming, or lock-bit configuration during power transitions. Internal circuitry resets the CUI to read array mode at power-up.

A system designer must guard against spurious writes for V_{CC} voltages above V_{LKO} when V_{PEN} is active. Since WE# must be low and the device enabled (see Table 2, *Chip Enable Truth Table*) for a command write, driving WE# to V_{IH} or disabling the device will inhibit writes. The CUI's two-step command sequence architecture provides added protection against data alteration.

Keeping V_{PEN} below V_{PENLK} prevents inadvertent data alteration. In-system block lock and unlock capability protects the device against inadvertent programming. The device is disabled while RP# = V_{IL} regardless of its control inputs.

5.7 Power Dissipation

When designing portable systems, designers must consider battery power consumption not only during device operation, but also for data retention during system idle time. Flash memory's nonvolatility increases usable battery life because data is retained when system power is removed.

6.0 ELECTRICAL SPECIFICATIONS

6.1 Absolute Maximum Ratings*

Temperature under Bias	
Expanded	-20 °C to +70 °C
Storage Temperature	-65 °C to +125 °C
Voltage On Any Pin (except RP#)	
.....	-2.0 V to +7.0 V ⁽¹⁾
RP# Voltage with Respect to GND during Lock-Bit Configuration Operations	-2.0 V to +14.0 V ^(1,2,3)
Output Short Circuit Current.....	100 mA ⁽⁴⁾

NOTES:

- All specified voltages are with respect to GND. Minimum DC voltage is -0.5 V on input/output pins and -0.2 V on V_{CC} and V_{PEN} pins. During transitions, this level may undershoot to -2.0 V for periods <20 ns. Maximum DC voltage on input/output pins, V_{CC}, and V_{PEN} is V_{CC} +0.5 V which, during transitions, may overshoot to V_{CC} +2.0 V for periods <20 ns.
- Maximum DC voltage on RP# may overshoot to +14.0 V for periods <20 ns.
- RP# voltage is normally at V_{IL} or V_{IH}. Connection to supply of V_{IH} is allowed for a maximum cumulative period of 80 hours.
- Output shorted for no more than one second. No more than one output shorted at a time.

NOTICE: This datasheet contains preliminary information on new products in production. The specifications are subject to change without notice. Verify with your local Intel Sales office that you have the latest datasheet before finalizing a design.

**WARNING: Stressing the device beyond the "Absolute Maximum Ratings" may cause permanent damage. These are stress ratings only. Operation beyond the "Operating Conditions" is not recommended and extended exposure beyond the "Operating Conditions" may affect device reliability.*

6.2 Operating Conditions

Temperature and V_{CC} Operating Conditions

Symbol	Parameter	Notes	Min	Max	Unit	Test Condition
T _A	Operating Temperature		-20	+70	°C	Ambient Temperature
V _{CC}	V _{CC1} Supply Voltage (5 V ± 10%)		4.50	5.50	V	
V _{CCQ1}	V _{CCQ1} Supply Voltage (5 V ± 10%)		4.50	5.50	V	
V _{CCQ2}	V _{CCQ2} Supply Voltage (2.7V-3.6 V)		2.70	3.60	V	

6.3 Capacitance⁽¹⁾

T_A = +25°C, f = 1 MHz

Symbol	Parameter	Typ	Max	Unit	Condition
C _{IN}	Input Capacitance	6	8	pF	V _{IN} = 0.0 V
C _{OUT}	Output Capacitance	8	12	pF	V _{OUT} = 0.0 V

NOTE:

- Sampled, not 100% tested.

6.4 DC Characteristics

Sym	Parameter	Notes	Typ	Max	Unit	Test Conditions
I_{LI}	Input and V_{PEN} Load Current	1		± 1	μA	$V_{CC} = V_{CC} \text{ Max}$ $V_{IN} = V_{CC} \text{ or GND}$
I_{LO}	Output Leakage Current	1		± 10	μA	$V_{CC} = V_{CC} \text{ Max}$ $V_{IN} = V_{CC} \text{ or GND}$
I_{CCS}	V_{CC} Standby Current	1,3,5	80	150	μA	CMOS Inputs, $V_{CC} = V_{CC} \text{ Max}$, $CE_0 = CE_1 = CE_2 = RP\# = V_{CCQ1} \pm 0.2 \text{ V}$
			450	900	μA	CMOS Inputs, $RP\# = V_{CC} = V_{CC} \text{ Max}$, $CE_0 = CE_1 = CE_2 = V_{CCQ2} \text{ Min}$
			325	650	μA	CMOS Inputs, $RP\# = V_{CC} = V_{CC} \text{ Max}$, $CE_2 = GND, CE_0 = CE_1 = V_{CCQ2} \text{ Min}$
			210	400	μA	CMOS Inputs, $RP\# = V_{CC} = V_{CC} \text{ Max}$, $CE_1 = CE_2 = GND, CE_0 = V_{CCQ2} \text{ Min or}$ $CE_0 = CE_2 = GND, CE_1 = V_{CCQ2} \text{ Min}$
			0.71	2	mA	TTL Inputs, $V_{CC} = V_{CC} \text{ Max}$, $CE_0 = CE_1 = CE_2 = RP\# = V_{IH}$
I_{CCD}	V_{CC} Power-Down Current		80	125	μA	$RP\# = GND \pm 0.2 \text{ V}$ $I_{OUT} (\text{STS}) = 0 \text{ mA}$
I_{CCR}	V_{CC} Read Current	1,5,6	35	55	mA	CMOS Inputs, $V_{CC} = V_{CCQ} = V_{CC} \text{ Max}$ Device is enabled (see Table 2, <i>Chip Enable Truth Table</i>) $f = 5 \text{ MHz}$ $I_{OUT} = 0 \text{ mA}$
			45	65	mA	TTL Inputs, $V_{CC} = V_{CC} \text{ Max}$ Device is enabled (see Table 2, <i>Chip Enable Truth Table</i>) $f = 5 \text{ MHz}$ $I_{OUT} = 0 \text{ mA}$
I_{CCW}	V_{CC} Program or Set Lock-Bit Current	1,6,7	35	60	mA	CMOS Inputs, $V_{PEN} = V_{CC}$
			40	70	mA	TTL Inputs, $V_{PEN} = V_{CC}$
I_{CCE}	V_{CC} Block Erase or Clear Block Lock-Bits Current	1,6,7	35	70	mA	CMOS Inputs, $V_{PEN} = V_{CC}$
			40	80	mA	TTL Inputs, $V_{PEN} = V_{CC}$
I_{CCES}	V_{CC} Block Erase Suspend Current	1,2		10	mA	Device is disabled (see Table 2, <i>Chip Enable Truth Table</i>)

6.4 DC Characteristics (Continued)

Sym	Parameter	Notes	Min	Max	Unit	Test Conditions
V _{IL}	Input Low Voltage	7	-0.5	0.8	V	
V _{IH}	Input High Voltage	7	2.0	V _{CC} + 0.5	V	
V _{OL}	Output Low Voltage	3,7		0.45	V	V _{CCQ} = V _{CCQ1} Min I _{OL} = 5.8 mA
				0.4	V	V _{CCQ} = V _{CCQ2} Min I _{OL} = 2 mA
V _{OH}	Output High Voltage	3,7	2.4		V	V _{CCQ} = V _{CCQ1} Min or V _{CCQ} = V _{CCQ2} Min I _{OH} = -2.5 mA (V _{CCQ1}) -2 mA (V _{CCQ2})
			0.85 X V _{CCQ}		V	V _{CCQ} = V _{CCQ1} Min or V _{CCQ} = V _{CCQ2} Min I _{OH} = -2.5 mA
			V _{CCQ} -0.4		V	V _{CCQ} = V _{CCQ1} Min or V _{CCQ} = V _{CCQ2} Min I _{OH} = -100 µA
V _{PENLK}	V _{PEN} Lockout during Normal Operations	4,7,11	3.6		V	
V _{PENH}	V _{PEN} during Block Erase, Program, or Lock-Bit Operations	4,11	4.5	5.5	V	
V _{LKO}	V _{CC} Lockout Voltage	8	3.25		V	
V _{HH}	RP# Unlock Voltage	9,10	11.4	12.6	V	Set master lock-bit Override lock-bit

NOTES:

- All currents are in RMS unless otherwise noted. These currents are valid for all product versions (packages and speeds). Contact Intel's Application Support Hotline or your local sales office for information about typical specifications.
- I_{CCES} is specified with the device de-selected. If the device is read or written while in erase suspend mode, the device's current draw is I_{CCR} or I_{CCW}.
- Includes STS.
- Block erases, programming, and lock-bit configurations are inhibited when V_{PEN} ≤ V_{PENLK}, and not guaranteed in the range between V_{PENLK} (max) and V_{PENH} (min), and above V_{PENH} (max).
- CMOS inputs are either V_{CC} ± 0.2 V or GND ± 0.2 V. TTL inputs are either V_{IL} or V_{IH}.
- Add 5 mA for V_{CCQ} = V_{CCQ2} min.
- Sampled, not 100% tested.
- Block erases, programming, and lock-bit configurations are inhibited when V_{CC} < V_{LKO}, and not guaranteed in the range between V_{LKO} (min) and V_{CC} (min), and above V_{CC} (max).
- Master lock-bit set operations are inhibited when RP# = V_{IH}. Block lock-bit configuration operations are inhibited when the master lock-bit is set and RP# = V_{IH}. Block erases and programming are inhibited when the corresponding block-lock bit is set and RP# = V_{IH}. Block erase, program, and lock-bit configuration operations are not guaranteed and should not be attempted with V_{IH} < RP# < V_{HH}.
- RP# connection to a V_{HH} supply is allowed for a maximum cumulative period of 80 hours.
- Tie V_{PEN} to V_{CC} (4.5 V–5.5 V).

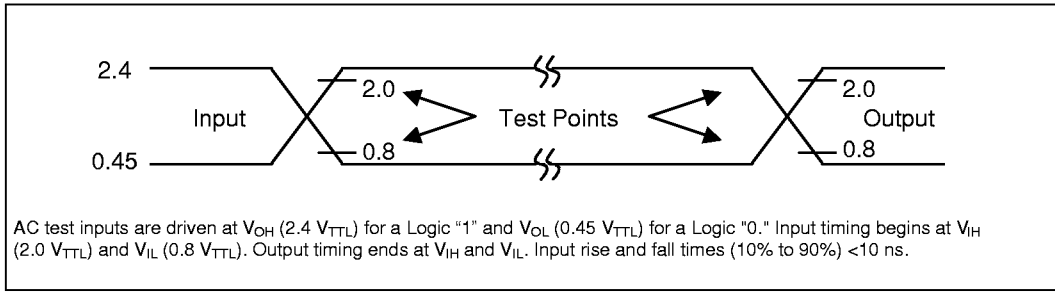

Figure 13. Transient Input/Output Reference Waveform for $V_{CCQ} = 5.0\text{ V} \pm 10\%$ (Standard Testing Configuration)

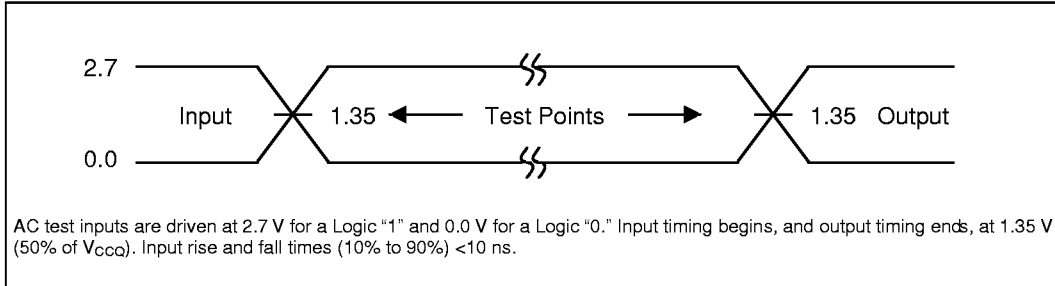

Figure 14. Transient Input/Output Reference Waveform for $V_{CCQ} = 2.7\text{ V}–3.6\text{ V}$

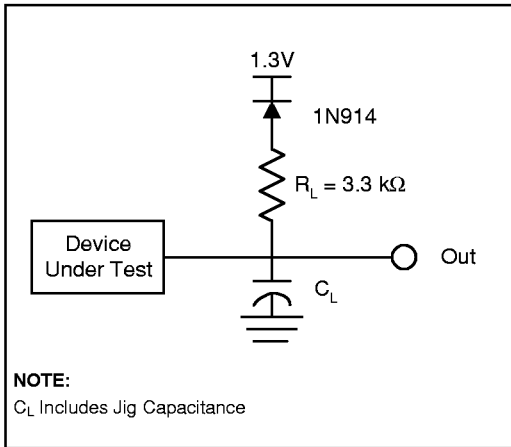

Figure 15. Transient Equivalent Testing Load Circuit

Test Configuration Capacitance Loading Value

Test Configuration	C_L (pF)
$V_{CCQ} = 5.0\text{ V} \pm 10\%$	100
$V_{CCQ} = 2.7\text{ V}–3.6\text{ V}$	50

6.5 AC Characteristics—Read-Only Operations⁽¹⁾

Versions		5 V ± 10% V _{CCQ}	–120/–150 ⁽⁴⁾		
(All units in ns unless otherwise noted)		2.7 V–3.6V V _{CCQ}	–120/–150 ⁽⁴⁾		
#	Sym	Parameter	Notes	Min	Max
R1	t _{AVAV}	Read/Write Cycle Time	32 Mbit		120
			64 Mbit		150
R2	t _{AVQV}	Address to Output Delay	32 Mbit		120
			64 Mbit		150
R3	t _{ELQV}	CE _X to Output Delay	32 Mbit	2	120
			64 Mbit	2	150
R4	t _{GLQV}	OE# to Output Delay	2		50
R5	t _{PHQV}	RP# High to Output Delay	32 Mbit		180
			64 Mbit		210
R6	t _{ELQX}	CE _X to Output in Low Z	3	0	
R7	t _{GLQX}	OE# to Output in Low Z	3	0	
R8	t _{EHQZ}	CE _X High to Output in High Z	3		55
R9	t _{GHQZ}	OE# High to Output in High Z	3		15
R10	t _{OH}	Output Hold from Address, CE _X , or OE# Change, Whichever Occurs First	3	0	
R11	t _{ELFL}	CE _X Low to BYTE# High or Low	3		10
	t _{ELFH}				
R12	t _{FLQV}	BYTE# to Output Delay			1000
	t _{FHQV}				
R13	t _{FLQZ}	BYTE# to Output in High Z	3		1000
R14	t _{EHEL}	CE _X Disable Pulse Width	3	10	

NOTES:

CE_X low is defined as the first edge of CE₀, CE₁, or CE₂ that enables the device. CE_X high is defined at the first edge of CE₀, CE₁, or CE₂ that disables the device (see Table 2, *Chip Enable Truth Table*).

- See Figure 16, *AC Waveform for Read Operations* for the maximum allowable input slew rate.
- OE# may be delayed up to t_{ELQV}–t_{GLQV} after the first edge of CE₀, CE₁, or CE₂ that enables the device (see Table 2, *Chip Enable Truth Table*) without impact on t_{ELQV}.
- Sampled, not 100% tested.
- See Figures 13–15, *Transient Input/Output Reference Waveform for V_{CCQ} = 5.0 V ± 10%*, *Transient Input/Output Reference Waveform for V_{CCQ} = 2.7 V–3.6 V*, and *Transient Equivalent Testing Load Circuit* for testing characteristics.

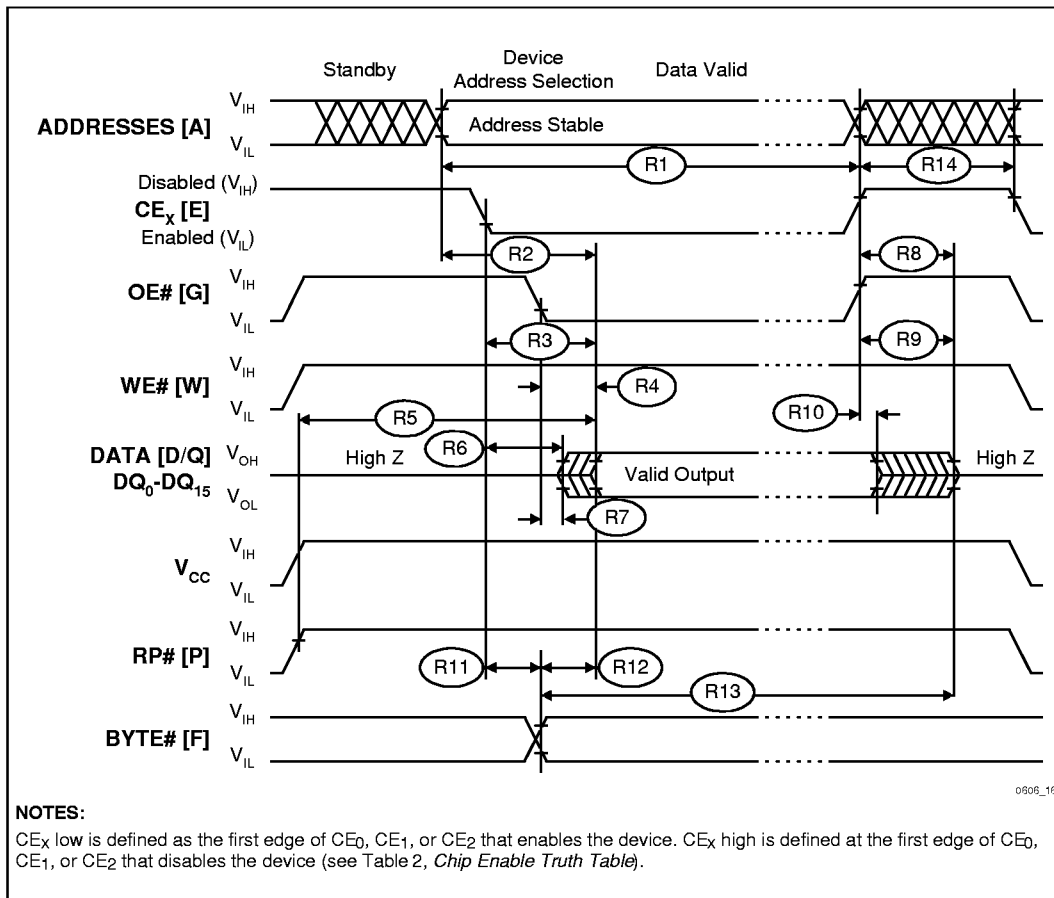

Figure 16. AC Waveform for Read Operations

6.6 AC Characteristics— Write Operations^(1,2)

Versions				Valid for All Speeds		Unit
#	Sym	Parameter	Notes	Min	Max	
W1	t _{PHWL} (t _{PHL})	RP# High Recovery to WE# (CE _x) Going Low	3	1		μs
W2	t _{ELWL} (t _{WLEL})	CE _x (WE#) Low to WE# (CE _x) Going Low	8	0		ns
W3	t _{WP}	Write Pulse Width	8	70		ns
W4	t _{DVWH} (t _{DVEH})	Data Setup to WE# (CE _x) Going High	4	50		ns
W5	t _{AVWH} (t _{AVEH})	Address Setup to WE# (CE _x) Going High	4	50		ns
W6	t _{WHEH} (t _{EHWH})	CE _x (WE#) Hold from WE# (CE _x) High		10		ns
W7	t _{WHDX} (t _{EHDX})	Data Hold from WE# (CE _x) High		0		ns
W8	t _{WHAX} (t _{EHAX})	Address Hold from WE# (CE _x) High		0		ns
W9	t _{WPH}	Write Pulse Width High	9	30		ns
W10	t _{PHHWH} (t _{PHHEH})	RP# V _{HH} Setup to WE# (CE _x) Going High	3	0		ns
W11	t _{VPWH} (t _{VPEH})	V _{PEN} Setup to WE# (CE _x) Going High	3	0		ns
W12	t _{WHGL} (t _{EHGL})	Write Recovery before Read	6	35		ns
W13	t _{WHRL} (t _{EHRL})	WE# (CE _x) High to STS Going Low	5		90	ns
W14	t _{QVPH}	RP# V _{HH} Hold from Valid SRD, STS Going High	3,5,7	0		ns
W15	t _{QVVL}	V _{PEN} Hold from Valid SRD, STS Going High	3,5,7	0		ns

NOTES:

CE_x low is defined as the first edge of CE₀, CE₁, or CE₂ that enables the device. CE_x high is defined at the first edge of CE₀, CE₁, or CE₂ that disables the device (see Table 2, *Chip Enable Truth Table*).

- Read timing characteristics during block erase, program, and lock-bit configuration operations are the same as during read-only operations. Refer to *AC Characteristics—Read-Only Operations*.
- A write operation can be initiated and terminated with either CE_x or WE#.
- Sampled, not 100% tested.
- Refer to Table 4 for valid A_{IN} and D_{IN} for block erase, program, or lock-bit configuration.
- STS timings are based on STS configured in its RY/BY# default mode.
- For array access, t_{AVQV} is required in addition to t_{WHGL} for any accesses after a write.
- V_{PEN} should be held at V_{PENH} (and if necessary RP# should be held at V_{HH}) until determination of block erase, program, or lock-bit configuration success (SR.1/3/4/5 = 0).
- Write pulse width (t_{WP}) is defined from CE_x or WE# going low (whichever goes low first) to CE_x or WE# going high (whichever goes high first). Hence, t_{WP} = t_{WLWH} = t_{LEH} = t_{WLEH} = t_{ELWH}. If CE_x is driven low 10 ns before WE# going low, WE# pulse width requirement decreases to t_{WP} - 10 ns.
- Write pulse width high (t_{WPH}) is defined from CE_x or WE# going high (whichever goes high first) to CE_x or WE# going low (whichever goes low first). Hence, t_{WPH} = t_{WHWL} = t_{HEH} = t_{WHEL} = t_{EHWL}.

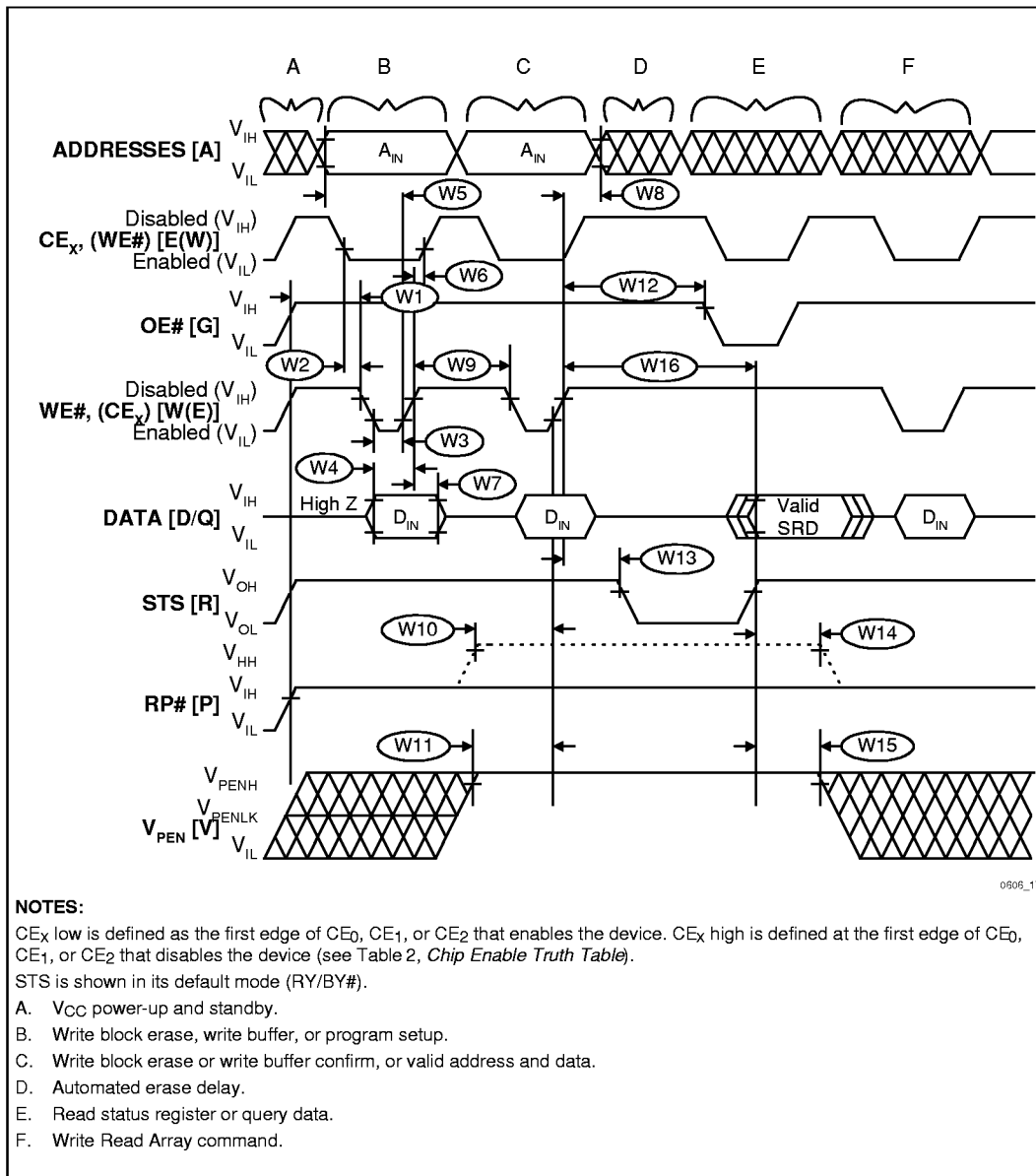

Figure 17. AC Waveform for Write Operations

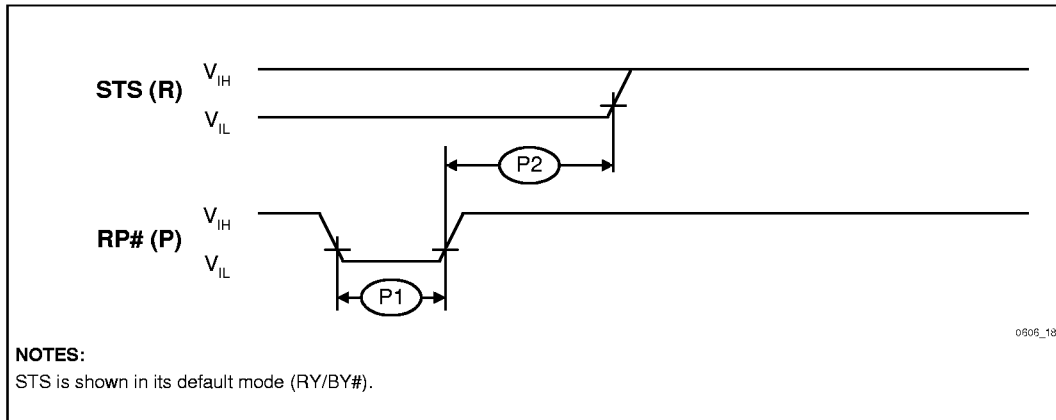

Figure 18. AC Waveform for Reset Operation

Reset Specifications⁽¹⁾

#	Sym.	Parameter	Notes	Min	Max	Unit
P1	t_{PLPH}	RP# Pulse Low Time (If RP# is tied to V_{CC} , this specification is not applicable)	2	35		μs
P2	t_{PHRH}	RP# High to Reset during Block Erase, Program, or Lock-Bit Configuration	3		100	ns

NOTES:

1. These specifications are valid for all product versions (packages and speeds).
2. If RP# is asserted while a block erase, program, or lock-bit configuration operation is not executing then the minimum required RP# Pulse Low Time is 100 ns.
3. A reset time, t_{RQV} , is required from the latter of STS (in RY/BY# mode) or RP# going high until outputs are valid.

6.7 Block Erase, Program, and Lock-Bit Configuration Performance^(3,4)

#	Sym	Parameter	Notes	Typ ⁽¹⁾	Max	Unit
W16		Write Buffer Byte Program Time	2,5,6,7	202	480	μs
W16	t _{WHQV3} t _{EHQV3}	Byte Program Time (Using Word/Byte Program Command)	2	180	TBD	μs
		Block Program Time (Using Write to Buffer Command)	2	0.8	TBD	sec
W16	t _{WHQV4} t _{EHQV4}	Block Erase Time	2	0.7	TBD	sec
W16	t _{WHQV5} t _{EHQV5}	Set Lock-Bit Time	2	32	TBD	μs
W16	t _{WHQV6} t _{EHQV6}	Clear Block Lock-Bits Time	2	0.3	TBD	sec
W16	t _{WHRH} t _{EHRH}	Erase Suspend Latency Time to Read		26	35	μs

NOTES:

1. Typical values measured at T_A = +25 °C and nominal voltages. Assumes corresponding lock-bits are not set. Subject to change based on device characterization.
2. Excludes system-level overhead.
3. These performance numbers are valid for all speed versions.
4. Sampled but not 100% tested.
5. These values are valid when the buffer is full, and the start address is aligned on a 32-byte boundary.
6. Effective per-byte program time (t_{WHQV1}, t_{EHQV1}) is 6.3 μs/byte (typical).
7. Effective per-word program time (t_{WHQV2}, t_{EHQV2}) is 12.6 μs/byte (typical).

7.0 ORDERING INFORMATION

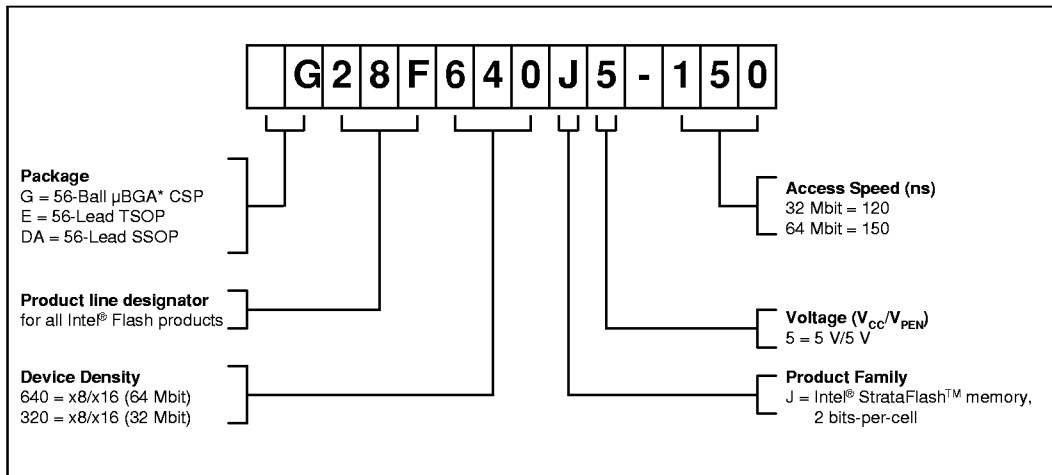

Order Code by Density		Valid Operational Conditions 5 V V_{CC}	
32 Mbit	64 Mbit	2.7 V – 3.6 V V_{CCQ}	5 V \pm 10% V_{CCQ}
DA28F320J5-120	DA28F640J5-150	Yes	Yes
E28F320J5-120		Yes	Yes
	G28F640J5-150	Yes	Yes

8.0 ADDITIONAL INFORMATION^(1,2)

Order Number	Document/Tool
Contact Intel/Distribution Sales Office	5 Volt Intel® StrataFlash™ Memory 0.25 μ Generation/32-, 64-, and 128-Mbit Densities EAS
210830	Flash Memory Databook
290608	3 Volt FlashFile™ Memory; 28F160S3 and 28F320S3 datasheet
290609	5 Volt FlashFile™ Memory; 28F160S5 and 28F320S5 datasheet
290429	5 Volt FlashFile™ Memory; 28F008SA datasheet
290598	3 Volt FlashFile™ Memory; 28F004S3, 28F008S3, 28F016S3 datasheet
290597	5 Volt FlashFile™ Memory; 28F004S5, 28F008S5, 28F016S5 datasheet
292235	AP-687 5 Volt Intel® StrataFlash™ Memory Interface to the SA-1100
297859	AP-677 Intel® StrataFlash™ Memory Technology
292222	AP-664 Designing Intel® StrataFlash™ Memory into Intel® Architecture
292221	AP-663 Using the Intel® StrataFlash™ Memory Write Buffer
292218	AP-660 Migration Guide to 3 Volt Intel® StrataFlash™ Memory
292205	AP-647 5 Volt Intel® StrataFlash™ Memory Design Guide
292204	AP-646 Common Flash Interface (CFI) and Command Sets
292202	AP-644 Migration Guide to 5 Volt Intel® StrataFlash™ Memory
297846	Comprehensive User's Guide for μBGA* Packages
Note 3	28F016SA 16-Mbit (1 Mbit x 16, 2 Mbit x 8) FlashFile™ Memory datasheet
Note 3	DD28F032SA 32-Mbit (2 Mbit x 16, 4 Mbit x 8) FlashFile™ Memory datasheet
Note 3	28F016SV 16-Mbit (1 Mbit x 16, 2 Mbit x 8) FlashFile™ Memory datasheet

NOTES:

1. Please call the Intel Literature Center at (800) 548-4725 to request Intel documentation. International customers should contact their local Intel or distribution sales office.
2. Visit Intel's World Wide Web home page at <http://www.intel.com> for technical documentation and tools.
3. These documents can be located at the Intel World Wide Web support site, <http://www.intel.com/support/flash/memory>
4. For the most current information on Intel StrataFlash memory, visit our website at <http://developer.intel.com/design/flash/isf>.