



T-52-11

100324

100324

Low Power Hex TTL-to-ECL Translator

General Description

The 100324 is a hex translator, designed to convert TTL logic levels to 100K ECL logic levels. The inputs are compatible with standard or Schottky TTL. A common Enable (E), when LOW, holds all inverting outputs HIGH and holds all true outputs LOW. The differential outputs allow each circuit to be used as an inverting/non-inverting translator, or as a differential line driver. The output levels are voltage compensated over the full -4.2V to -5.7V range.

When the circuit is used in the differential mode, the 100324, due to its high common mode rejection, overcomes voltage gradients between the TTL and ECL ground systems. The V_{EE} and V_{TTL} power may be applied in either order.

The 100324 is pin and function compatible with the 100124 with similar AC performance, but features power dissipation

roughly half of the 100124 to ease system cooling requirements.

Features

- Pin/function compatible with 100124
- Meets 100124 AC specifications
- 50% power reduction of the 100124
- Differential outputs
- 2000V ESD protection
- -4.2V to -5.7V operating range
- Available to MIL-STD-883
- Available to industrial grade temperature range

Ordering Code: See Section 6

Logic Diagram

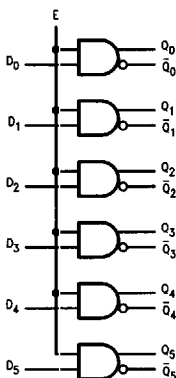

TL/F/9878-4

Pin Names	Description
D ₀ -D ₅	Data Inputs
E	Enable Input
Q ₀ -Q ₅	Data Outputs
\bar{Q}_0 - \bar{Q}_5	Complementary Data Outputs

Connection Diagrams

24-Pin DIP/SOIC

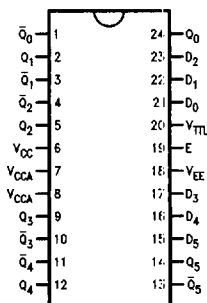

TL/F/9878-1

28-Pin PCC

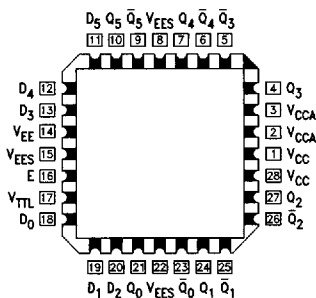

TL/F/9878-3

24-Pin Quad Cerpak

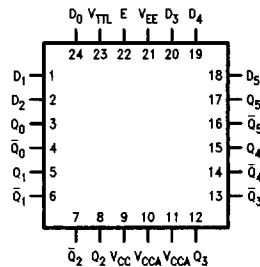

TL/F/9878-2

10032

Absolute Maximum Ratings

Above which the useful life may be impaired. (Note 1)

If Military/Aerospace specified devices are required, please contact the National Semiconductor Sales Office/Distributors for availability and specifications.

Storage Temperature (T_{STG}) -65°C to +150°C

Maximum Junction Temperature (T_J)

Ceramic +175°C

Plastic +150°C

V_{EE} Pin Potential to Ground Pin -7.0V to +0.5V

V_{TTL} Pin Potential to Ground Pin -0.5V to +6.0V

Input Voltage (DC) -0.5V to +6.0V

Output Current (DC Output HIGH) -50 mA

ESD (Note 2) ≥2000V

Note 1: Absolute maximum ratings are those values beyond which the device may be damaged or have its useful life impaired. Functional operation under these conditions is not implied.

Note 2: ESD testing conforms to MIL-STD-883, Method 3015.

Commercial Version

DC Electrical Characteristics

V_{EE} = -4.2V to -5.7V, V_{CC} = V_{CCA} = GND, T_C = 0°C to +85°C (Note 3), V_{TTL} = +4.5V to +5.5V

Symbol	Parameter	Min	Typ	Max	Units	Conditions
V _{OH}	Output HIGH Voltage	-1025	-955	-870	mV	V _{IN} = V _{IH} (Max) or V _{IL} (Min) Loading with 50Ω to -2.0V
V _{OL}	Output LOW Voltage	-1830	-1705	-1620		
V _{OHC}	Output HIGH Voltage	-1035			mV	V _{IN} = V _{IH} (Min) or V _{IL} (Max) Loading with 50Ω to -2.0V
V _{OLC}	Output LOW Voltage			-1610		
V _{IH}	Input HIGH Voltage	2.0		5.0	V	Guaranteed HIGH Signal for All Inputs
V _{IL}	Input LOW Voltage	0		0.8	V	Guaranteed LOW Signal for All Inputs
V _{CD}	Input Clamp Diode Voltage	-1.2			V	I _{IN} = -18 mA
I _{IH}	Input HIGH Current Data Enable			20 120	μA	V _{IN} = +2.4V, All Other Inputs V _{IN} = GND
	Input HIGH Current Breakdown Test, All Inputs			1.0	mA	V _{IN} = +5.5V, All Other Inputs = GND
I _{IL}	Input LOW Current Data Enable	-0.9 -5.4			mA	V _{IN} = +0.4V, All Other Inputs V _{IN} = V _{IH}
I _{EE}	V _{EE} Power Supply Current	-70	-45	-22	mA	All Inputs V _{IN} = +4.0V
I _{TTL}	V _{TTL} Power Supply Current		25	38	mA	All Inputs V _{IN} = GND

Note 3: The specified limits represent the "worst case" value for the parameter. Since these values normally occur at the temperature extremes, additional noise immunity and guardbanding can be achieved by decreasing the allowable system operating ranges. Conditions for testing shown in the tables are chosen to guarantee operation under "worst case" conditions.

Commercial Version (Continued)

DIP AC Electric Characteristics

$V_{EE} = -4.2V$ to $-5.7V$, $V_{CC} = V_{CCA} = GND$, $V_{TTL} = +4.5V$ to $+5.5V$

Symbol	Parameter	$T_C = 0^\circ C$		$T_C = +25^\circ C$		$T_C = +85^\circ C$		Units	Conditions
		Min	Max	Min	Max	Min	Max		
t_{PLH} t_{PHL}	Propagation Delay Data and Enable to Output	0.50	3.00	0.50	2.90	0.50	3.00	ns	Figures 1 and 2
t_{TLH} t_{THL}	Transition Time 20% to 80%, 80% to 20%	0.45	1.80	0.45	1.80	0.45	1.80	ns	

SOIC, PCC and Cerpak AC Electrical Characteristics

$V_{EE} = -4.2V$ to $-5.7V$, $V_{CC} = V_{CCA} = GND$, $V_{TTL} = +4.5V$ to $+5.5V$

Symbol	Parameter	$T_C = 0^\circ C$		$T_C = +25^\circ C$		$T_C = +85^\circ C$		Units	Conditions
		Min	Max	Min	Max	Min	Max		
t_{PLH} t_{PHL}	Propagation Delay Data and Enable to Output	0.50	2.80	0.50	2.70	0.50	2.80	ns	Figures 1 and 2
t_{TLH} t_{THL}	Transition Time 20% to 80%, 80% to 20%	0.45	1.70	0.45	1.70	0.45	1.70	ns	
t_{OSHL}	Maximum Skew Com non Edge Output-to-Output Variation Data to Output Path		0.95		0.95		0.95	ns	PCC Only (Note 1)
t_{OSLH}	Maximum Skew Com non Edge Output-to-Output Variation Data to Output Path		0.70		0.70		0.70	ns	PCC Only (Note 1)
t_{OST}	Maximum Skew Opposite Edge Output-to-Output Variation Data to Output Path		1.60		1.60		1.60	ns	PCC Only (Note 1)
t_{PS}	Maximum Skew Pin (Signal) Transition Variation Data to Output Path		1.20		1.20		1.20	ns	PCC Only (Note 1)

Note 1: Output-to-Output Skew is defined as the absolute value of the difference between the actual propagation delay for any outputs within the same packaged device. The specifications apply to any outputs switching in the same direction either HIGH to LOW (t_{OSHL}), or LOW to HIGH (t_{OSLH}), or in opposite directions both HL and LH (t_{OST}). Parameters t_{OST} and t_{PS} guaranteed by design.

100324

Industrial Version

PCC DC Electrical Characteristics (Note)

$V_{EE} = -4.2V$ to $-5.7V$, $V_{CC} = V_{CCA} = GND$, $T_C = -40^{\circ}C$ to $+85^{\circ}C$, $V_{TTL} = +4.5V$ to $+5.5V$

Symbol	Parameter	$T_C = -40^{\circ}C$		$T_C = 0^{\circ}C$ to $+85^{\circ}C$		Units	Conditions	
		Min	Max	Min	Max			
V_{OH}	Output HIGH Voltage	-1085	-870	-1025	-870	mV	$V_{IN} = V_{IH} (Max)$ or $V_{IL} (Min)$	Loading with 50Ω to $-2.0V$
V_{OL}	Output LOW Voltage	-1830	-1575	-1830	-1620			
V_{OHC}	Output HIGH Voltage	-1095		-1035		mV	$V_{IN} = V_{IH}(Min)$ or $V_{IL} (Max)$	Loading with 50Ω to $-2.0V$
V_{OLC}	Output LOW Voltage		-1565		-1610			
V_{IH}	Input HIGH Voltage	2.0	5.0	2.0	5.0	V	Guaranteed HIGH Signal for All Inputs	
V_{IL}	Input LOW Voltage	0	0.8	0	0.8	V	Guaranteed LOW Signal for All Inputs	
V_{CD}	Input Clamp Diode Voltage	-1.2		-1.2		V	$I_{IN} = -18 mA$	
I_{IH}	Input HIGH Current Data Enable		20 120		20 120	μA	$V_{IN} = +2.4V$, All Other Inputs $V_{IN} = GND$	
	Input HIGH Current Breakdown Test, All Inputs		1.0		1.0			
I_{IL}	Input LOW Current Data Enable	-0.9 -5.4		-0.9 -5.4		mA	$V_{IN} = +0.4V$, All Other Inputs $V_{IN} = V_{IH}$	
I_{EE}	V_{EE} Power Supply Current	-70	-22	-70	-22	mA	All Inputs $V_{IN} = +4.0V$	
I_{TTL}	V_{TTL} Power Supply Current		38		38	mA	All Inputs $V_{IN} = GND$	

Note: The specified limits represent the "worst case" value for the parameter. Since these values normally occur at the temperature extremes, additional noise immunity and guardbanding can be achieved by decreasing the allowable system operating ranges. Conditions for testing shown in the tables are chosen to guarantee operation under "worst case" conditions.

PCC AC Electrical Characteristics

$V_{EE} = -4.2V$ to $-5.7V$, $V_{CC} = V_{CCA} = GND$, $V_{TTL} = +4.5V$ to $+5.5V$

Symbol	Parameter	$T_C = -40^{\circ}C$		$T_C = +25^{\circ}C$		$T_C = +85^{\circ}C$		Units	Conditions
		Min	Max	Min	Max	Min	Max		
t_{PLH} t_{PHL}	Propagation Delay Data and Enable to Output	0.50	2.80	0.50	2.70	0.50	2.80	ns	Figures 1 and 2
t_{TLH} t_{THL}	Transition Times 20% to 80%, 80% to 20%	0.35	1.80	0.45	1.70	0.45	1.70	ns	Figures 1 and 2

100324

Military Version

DC Electrical Characteristics

$V_{EE} = -4.2V$ to $-5.7V$, $V_{CC} = V_{CCA} = GND$, $T_C = -55^{\circ}C$ to $+125^{\circ}C$, $V_{TTL} = +4.5V$ to $+5.5V$

Symbol	Parameter	Min	Max	Units	T_C	Conditions	Notes	
V_{OH}	Output HIGH Voltage	-1025	-870	mV	$0^{\circ}C$ to $+125^{\circ}C$	$V_{IN} = V_{IH}$ (Max) or V_{IL} (Min)	Loading with 50Ω to $-2.0V$	1, 2, 3
		-1085	-870	mV	$-55^{\circ}C$			
V_{OL}	Output LOW Voltage	-1830	-1620	mV	$0^{\circ}C$ to $+125^{\circ}C$			
		-1830	-1555	mV	$-55^{\circ}C$			
V_{OHC}	Output HIGH Voltage	-1035		mV	$0^{\circ}C$ to $+125^{\circ}C$	$V_{IN} = V_{IH}$ (Max) or V_{IL} (Min)	Loading with 50Ω to $-2.0V$	1, 2, 3
		-1085		mV	$-55^{\circ}C$			
V_{OLC}	Output LOW Voltage		-1610	mV	$0^{\circ}C$ to $+125^{\circ}C$			
			-1555	mV	$-55^{\circ}C$			
V_{IH}	Input HIGH Voltage	2.0	5.0	V	$-55^{\circ}C$ to $+125^{\circ}C$	Over V_{TTL} , V_{EE} , T_C Range	1, 2, 3, 4	
V_{IL}	Input LOW Voltage	0.0	0.8	V	$-55^{\circ}C$ to $+125^{\circ}C$	Over V_{TTL} , V_{EE} , T_C Range	1, 2, 3, 4	
I_{IH}	Input HIGH Current Breakdown Test		20	μA	$-55^{\circ}C$ to $+125^{\circ}C$	$V_{IN} = +2.7V$	1, 2, 3	
			100	μA	$-55^{\circ}C$ to $+125^{\circ}C$	$V_{IN} = +7.0V$		
I_{IL}	Input LOW Current Data Enable	-0.9 -5.4		mA	$-55^{\circ}C$ to $+125^{\circ}C$	$V_{IN} = +0.4V$	1, 2, 3	
V_{FCD}	Input Clamp Diode Voltage		-1.2	V	$-55^{\circ}C$ to $+125^{\circ}C$	$I_{IN} = -18 mA$	1, 2, 3	
I_{EE}	V_{EE} Power Supply Current	-70	-22	mA	$-55^{\circ}C$ to $+125^{\circ}C$	All Inputs $V_{IN} = +4.0V$	1, 2, 3	
I_{TTL}	V_{TTL} Power Supply Current		38	mA	$-55^{\circ}C$ to $+125^{\circ}C$	All Inputs $V_{IN} = GND$	1, 2, 3	

Note 1: F100K 300 Series cold temperature testing is performed by temperature soaking (to guarantee junction temperature equals $-55^{\circ}C$), then testing immediately without allowing for the junction temperature to stabilize due to heat dissipation after power-up. This provides "cold start" specs which can be considered a worst case condition at cold temperatures.

Note 2: Screen tested 100% on each device at $-55^{\circ}C$, $+25^{\circ}C$, and $+125^{\circ}C$, Subgroups 1, 2, 3, 7, and 8.

Note 3: Sample tested (Method 5005, Table I) on each manufactured lot at $-55^{\circ}C$, $+25^{\circ}C$, and $+125^{\circ}C$, Subgroups A1, 2, 3, 7, and 8.

Note 4: Guaranteed by applying specified input condition and testing V_{OH}/V_{OL} .

AC Electrical Characteristics

$V_{EE} = -4.2V$ to $-5.7V$, $V_{CC} = V_{CCA} = GND$, $V_{TTL} = +4.5V$ to $+5.5V$

Symbol	Parameter	$T_C = -55^{\circ}C$		$T_C = +25^{\circ}C$		$T_C = +125^{\circ}C$		Units	Conditions	Notes
		Min	Max	Min	Max	Min	Max			
t_{PLH} t_{PHL}	Propagation Delay Data and Enable to O_L tput	0.50	3.00	0.50	2.90	0.30	3.30	ns	Figures 1 and 2	1, 2, 3,
t_{TLH} t_{THL}	Transition Time 20% to 80%, 80% to 20%	0.35	1.80	0.45	1.80	0.45	1.80	ns		4

Note 1: F100K 300 Series cold temperature testing is performed by temperature soaking (to guarantee junction temperature equals $-55^{\circ}C$), then testing immediately after power-up. This provides "cold start" specs which can be considered a worst case condition at cold temperatures.

Note 2: Screen tested 100% on each device at $+25^{\circ}C$ temperature only, Subgroup A9.

Note 3: Sample tested (Method 5005, Table I) on each manufactured lot at $+25^{\circ}C$, Subgroup A9, and at $+125^{\circ}C$ and $-55^{\circ}C$ temperatures, Subgroups A10 and A11.

Note 4: Not tested at $+25^{\circ}C$, $+125^{\circ}C$, and $-55^{\circ}C$ temperature (design characterization data).

2

100324

Switching Waveform

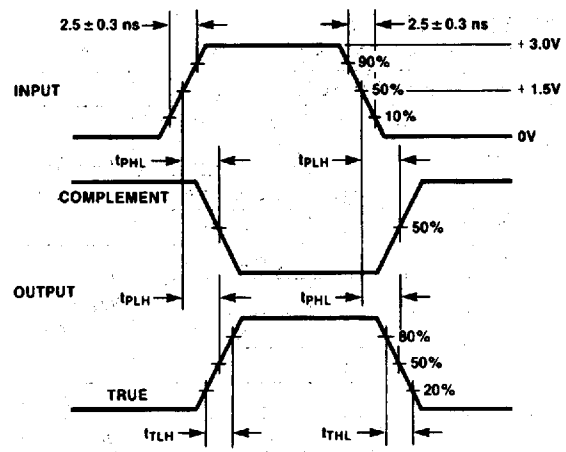

FIGURE 1. Propagation Delay and Transition Times

TL/F/9878-6

Test Circuit

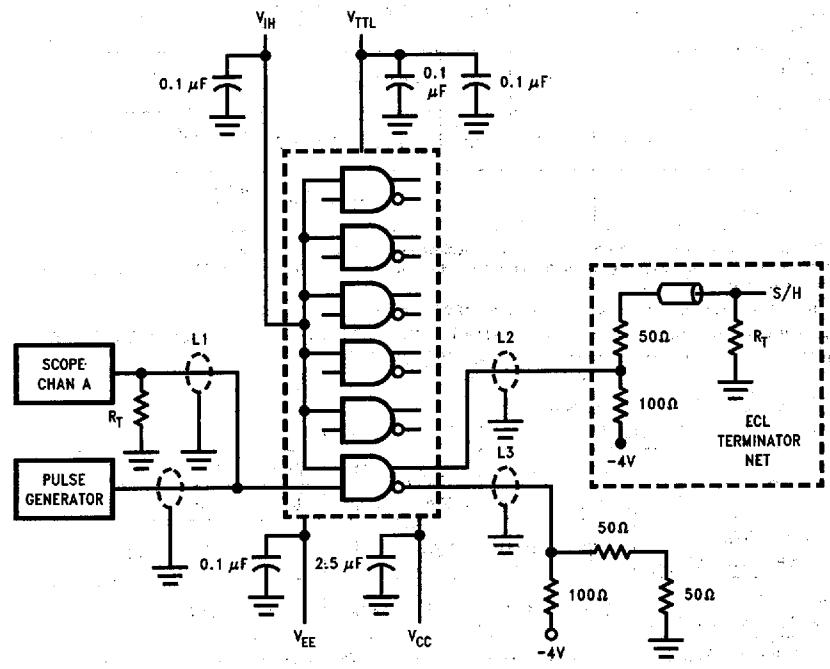

FIGURE 2. AC Test Circuit

TL/F/9878-5

- Notes:**
 $V_{CC}, V_{CCA} = 0V, V_{EE} = -4.5V, V_{TTL} = +5.0V, V_{IH} = +3.0V$
 L1, L2 and L3 = equal length 50 Ω impedance lines
 $R_T = 50\Omega$ terminator internal to scope
 Decoupling 0.1 μ F from GND to V_{CC}, V_{EE} and V_{TTL}
 All unused outputs are loaded with 50 Ω to -2V or with equivalent ECL terminator network
 $C_L =$ Fixture and stray capacitance ≤ 3 pF