

# HEF4016B

## Quad single-pole single-throw analog switch

Rev. 4 — 24 October 2016

Product data sheet

### 1. General description

The HEF4016B provides four single-pole, single-throw analog switch functions. Each switch has two input/output terminals (nY and nZ) and an active HIGH enable input (nE). When nE is LOW, the analog switch is turned off.

### 2. Features and benefits

- Fully static operation
- 5 V, 10 V, and 15 V parametric ratings
- Standardized symmetrical output characteristics
- Inputs and outputs are protected against electrostatic effects
- Specified from  $-40\text{ }^{\circ}\text{C}$  to  $+85\text{ }^{\circ}\text{C}$
- Complies with JEDEC standard JESD 13-B

### 3. Applications

- Analog multiplexing and demultiplexing
- Digital multiplexing and demultiplexing
- Signal gating

### 4. Ordering information

Table 1. Ordering information

Type number	Package			
	Temperature range	Name	Description	Version
HEF4016BT	$-40\text{ }^{\circ}\text{C}$ to $+85\text{ }^{\circ}\text{C}$	SO14	plastic small outline package; 14 leads; body width 3.9 mm	SOT108-1



**5. Functional diagram**

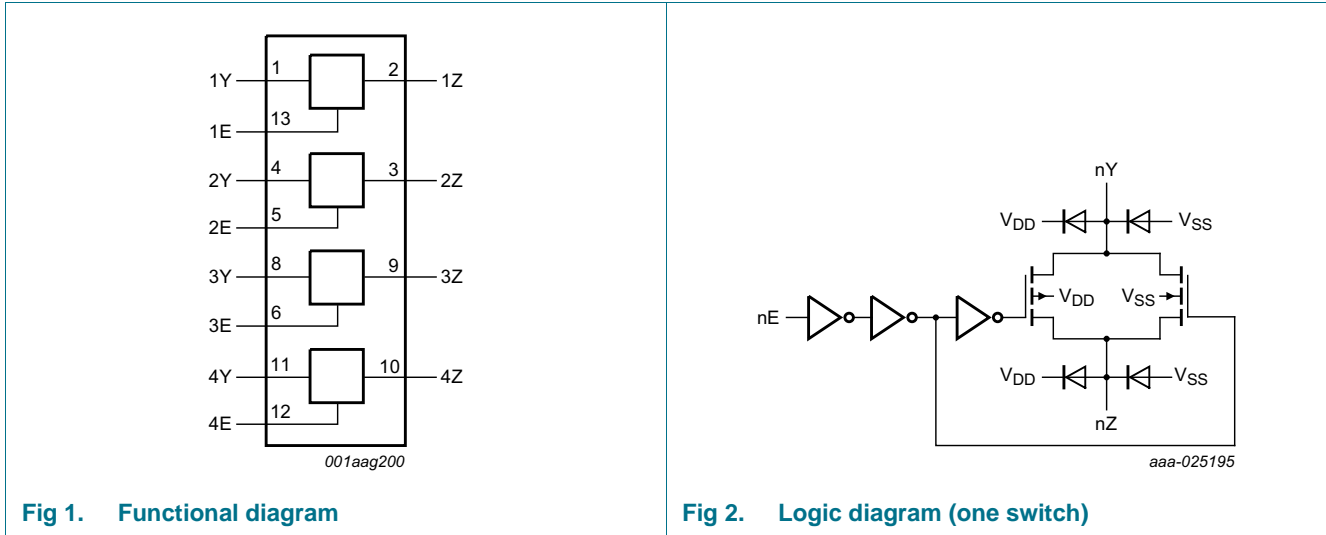

**6. Pinning information**

**6.1 Pinning**

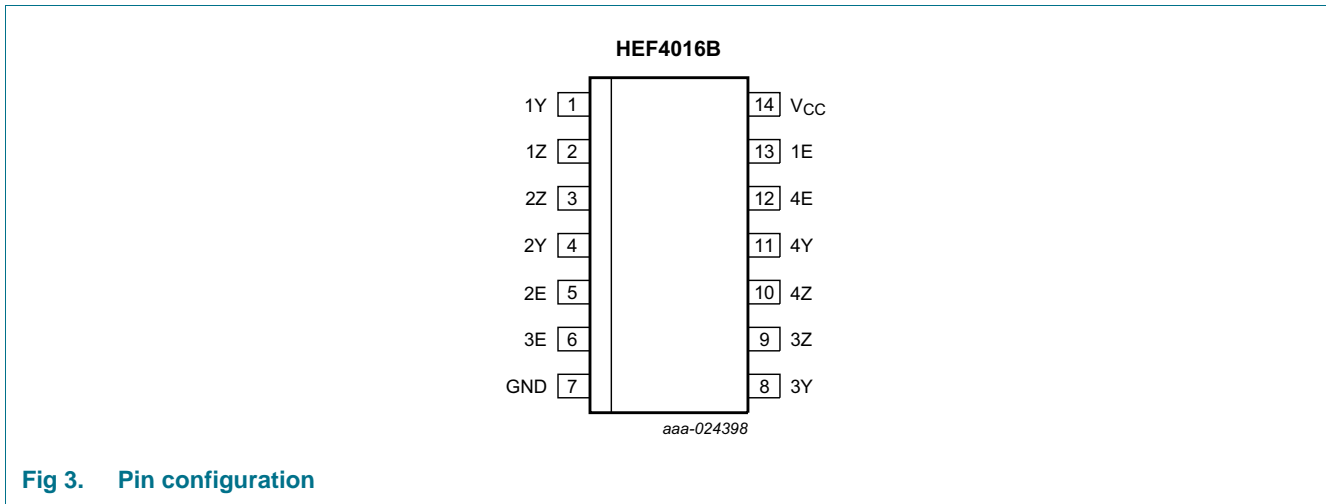

**6.2 Pin description**

**Table 2. Pin description**

Symbol	Pin	Description
1Y, 2Y, 3Y, 4Y	1, 4, 8, 11	independent input or output
1Z, 2Z, 3Z, 4Z	2, 3, 9, 10	independent input or output
1E, 2E, 3E, 4E	13, 5, 6, 12	enable input (active HIGH)
V <sub>SS</sub>	7	ground (0 V)
V <sub>DD</sub>	14	supply voltage

## 7. Functional description

Table 3. Function table<sup>[1]</sup>

Input nE	Switch
H	ON
L	OFF

[1] H = HIGH voltage level; L = LOW voltage level.

## 8. Limiting values

Table 4. Limiting values

In accordance with the Absolute Maximum Rating System (IEC 60134). Voltages are referenced to  $V_{SS} = 0$  V (ground).

Symbol	Parameter	Conditions	Min	Max	Unit
$V_{DD}$	supply voltage		-0.5	+18	V
$I_{IK}$	input clamping current	$V_I < -0.5$ V or $V_I > V_{DD} + 0.5$ V	-	$\pm 10$	mA
$V_I$	input voltage		-0.5	$V_{DD} + 0.5$	V
$I_{I/O}$	input/output current		[1]	$\pm 10$	mA
$T_{stg}$	storage temperature		-65	+150	°C
$T_{amb}$	ambient temperature		-40	+85	°C
$P_{tot}$	total power dissipation	$T_{amb} = -40$ °C to +85 °C			
		SO14	[2]	500	mW
P	power dissipation	per switch	-	100	mW

[1] To avoid drawing  $V_{DD}$  current out of terminal nZ, when switch current flows into terminals nY, the voltage drop across the bidirectional switch must not exceed 0.4 V. If the switch current flows into terminal nZ, no  $V_{DD}$  current will flow out of terminals nY, in this case there is no limit for the voltage drop across the switch, but the voltages at nY and nZ may not exceed  $V_{DD}$  or  $V_{SS}$ .

[2] For SO14 packages: above  $T_{amb} = 70$  °C,  $P_{tot}$  derates linearly with 8 mW/K.

## 9. Recommended operating conditions

Table 5. Recommended operating conditions

Symbol	Parameter	Conditions	Min	Typ	Max	Unit
$V_{DD}$	supply voltage		3	-	15	V
$V_I$	input voltage		0	-	$V_{DD}$	V
$T_{amb}$	ambient temperature	in free air	-40	-	+85	°C
$\Delta t/\Delta V$	input transition rise and fall rate	$V_{DD} = 5$ V	-	-	3.75	$\mu\text{s/V}$
		$V_{DD} = 10$ V	-	-	0.5	$\mu\text{s/V}$
		$V_{DD} = 15$ V	-	-	0.08	$\mu\text{s/V}$

## 10. Static characteristics

**Table 6. Static characteristics**

$V_{SS} = 0\text{ V}$ ;  $V_I = V_{SS}$  or  $V_{DD}$  unless otherwise specified.

Symbol	Parameter	Conditions	$V_{DD}$	$T_{amb} = -40\text{ }^{\circ}\text{C}$		$T_{amb} = 25\text{ }^{\circ}\text{C}$		$T_{amb} = 85\text{ }^{\circ}\text{C}$		Unit
				Min	Max	Min	Max	Min	Max	
$V_{IH}$	HIGH-level input voltage	$ I_O  < 1\text{ }\mu\text{A}$	5 V	3.5	-	3.5	-	3.5	-	V
			10 V	7.0	-	7.0	-	7.0	-	V
			15 V	11.0	-	11.0	-	11.0	-	V
$V_{IL}$	LOW-level input voltage	$ I_O  < 1\text{ }\mu\text{A}$	5 V	-	1.5	-	1.5	-	1.5	V
			10 V	-	3.0	-	3.0	-	3.0	V
			15 V	-	4.0	-	4.0	-	4.0	V
$I_I$	input leakage current		15 V	-	-	-	$\pm 0.3$	-	$\pm 1.0$	$\mu\text{A}$
$I_{S(OFF)}$	OFF-state leakage current	per channel; see <a href="#">Figure 4</a>	15 V	-	-	-	200	-	-	nA
$I_{DD}$	supply current	all valid input combinations	5 V	-	1.0	-	1.0	-	7.5	$\mu\text{A}$
			10 V	-	2.0	-	2.0	-	15.0	$\mu\text{A}$
			15 V	-	4.0	-	4.0	-	30.0	$\mu\text{A}$
$C_I$	input capacitance	nE input	-	-	-	-	7.5	-	-	pF

### 10.1 Test circuit

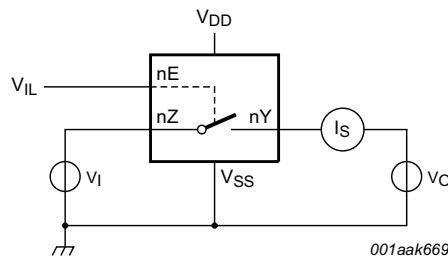

**Fig 4. Test circuit for measuring OFF-state leakage current**

10.2 ON resistance

Table 7. ON resistance

$T_{amb} = 25\text{ }^{\circ}\text{C}$ ;  $I_{SW} = 100\text{ }\mu\text{A}$ ;  $V_{SS} = 0\text{ V}$ .

Symbol	Parameter	Conditions	V <sub>DD</sub>	Typ	Max	Unit
R <sub>ON(peak)</sub>	ON resistance (peak)	V <sub>I</sub> = 0 V to V <sub>DD</sub> ; see <a href="#">Figure 5</a> and <a href="#">Figure 6</a>	5 V	8000	-	Ω
			10 V	230	690	Ω
			15 V	115	350	Ω
R <sub>ON(rail)</sub>	ON resistance (rail)	V <sub>I</sub> = 0 V; see <a href="#">Figure 5</a> and <a href="#">Figure 6</a>	5 V	140	425	Ω
			10 V	65	195	Ω
			15 V	50	145	Ω
		V <sub>I</sub> = V <sub>DD</sub> ; see <a href="#">Figure 5</a> and <a href="#">Figure 6</a>	5 V	170	515	Ω
			10 V	95	285	Ω
			15 V	75	220	Ω
ΔR <sub>ON</sub>	ON resistance mismatch between channels	V <sub>I</sub> = 0 V to V <sub>DD</sub> ; see <a href="#">Figure 5</a>	5 V	200	-	Ω
			10 V	15	-	Ω
			15 V	10	-	Ω

10.2.1 ON resistance waveform and test circuit

$R_{ON} = V_{SW} / I_{SW}$ .

001aak670

aaa-024399

$I_{SW} = 100\text{ }\mu\text{A}$ .

(1) V<sub>DD</sub> = 10 V  
(2) V<sub>DD</sub> = 15 V

**Fig 5. Test circuit for measuring R<sub>ON</sub>**

**Fig 6. Typical R<sub>ON</sub> as a function of input voltage**

## 11. Dynamic characteristics

**Table 8. Dynamic characteristics**

$T_{amb} = 25\text{ }^{\circ}\text{C}$ ;  $V_{SS} = 0\text{ V}$ ; for test circuit see [Figure 9](#).

Symbol	Parameter	Conditions	$V_{DD}$	Typ	Max	Unit
t <sub>PHL</sub>	HIGH to LOW propagation delay	nY, nZ to nZ, nY; see <a href="#">Figure 7</a>	5 V	25	50	ns
			10 V	10	20	ns
			15 V	5	10	ns
t <sub>PLH</sub>	LOW to HIGH propagation delay	nY, nZ to nZ, nY; see <a href="#">Figure 7</a>	5 V	20	40	ns
			10 V	10	20	ns
			15 V	5	10	ns
t <sub>PHZ</sub>	HIGH to OFF-state propagation delay	nE to nY, nZ; see <a href="#">Figure 8</a>	5 V	90	130	ns
			10 V	80	110	ns
			15 V	75	100	ns
t <sub>PLZ</sub>	LOW to OFF-state propagation delay	nE to nY, nZ; see <a href="#">Figure 8</a>	5 V	85	120	ns
			10 V	75	100	ns
			15 V	75	100	ns
t <sub>PZH</sub>	OFF-state to HIGH propagation delay	nE to nY, nZ; see <a href="#">Figure 8</a>	5 V	40	80	ns
			10 V	20	40	ns
			15 V	15	30	ns
t <sub>PZL</sub>	OFF-state to LOW propagation delay	nE to nY, nZ; see <a href="#">Figure 8</a>	5 V	40	80	ns
			10 V	20	40	ns
			15 V	15	30	ns

**Table 9. Dynamic power dissipation P<sub>D</sub>**

$P_D$  can be calculated from the formulas shown;  $V_{SS} = 0\text{ V}$ ;  $t_r = t_f \leq 20\text{ ns}$ ;  $T_{amb} = 25\text{ }^{\circ}\text{C}$ .

Symbol	Parameter	$V_{DD}$	Typical formula for P <sub>D</sub> (μW)	where:
P <sub>D</sub>	dynamic power dissipation	5 V	$P_D = 550 \times f_i + \Sigma(f_o \times C_L) \times V_{DD}^2$	$f_i$ = input frequency in MHz; $f_o$ = output frequency in MHz; $C_L$ = output load capacitance in pF; $V_{DD}$ = supply voltage in V; $\Sigma(f_o \times C_L)$ = sum of the outputs.
		10 V	$P_D = 2600 \times f_i + \Sigma(f_o \times C_L) \times V_{DD}^2$	
		15 V	$P_D = 6500 \times f_i + \Sigma(f_o \times C_L) \times V_{DD}^2$	

11.1 Waveforms and test circuit

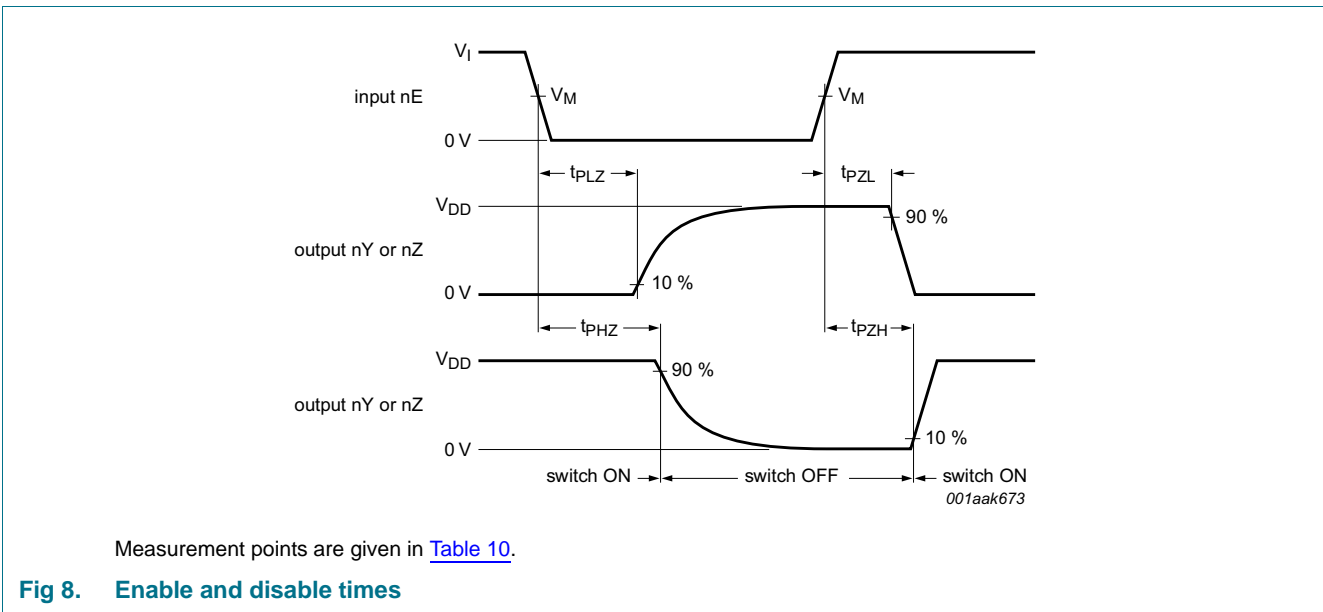
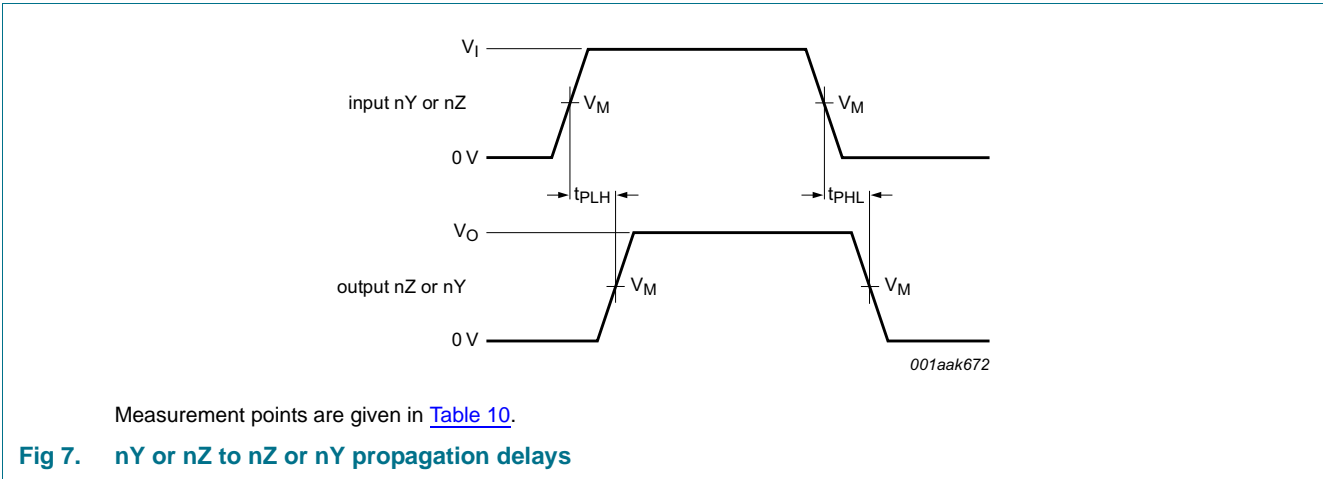

Table 10. Measurement points

Supply voltage	Input	Output
$V_{DD}$	$V_M$	$V_M$
5 V to 15 V	$0.5V_{DD}$	$0.5V_{DD}$

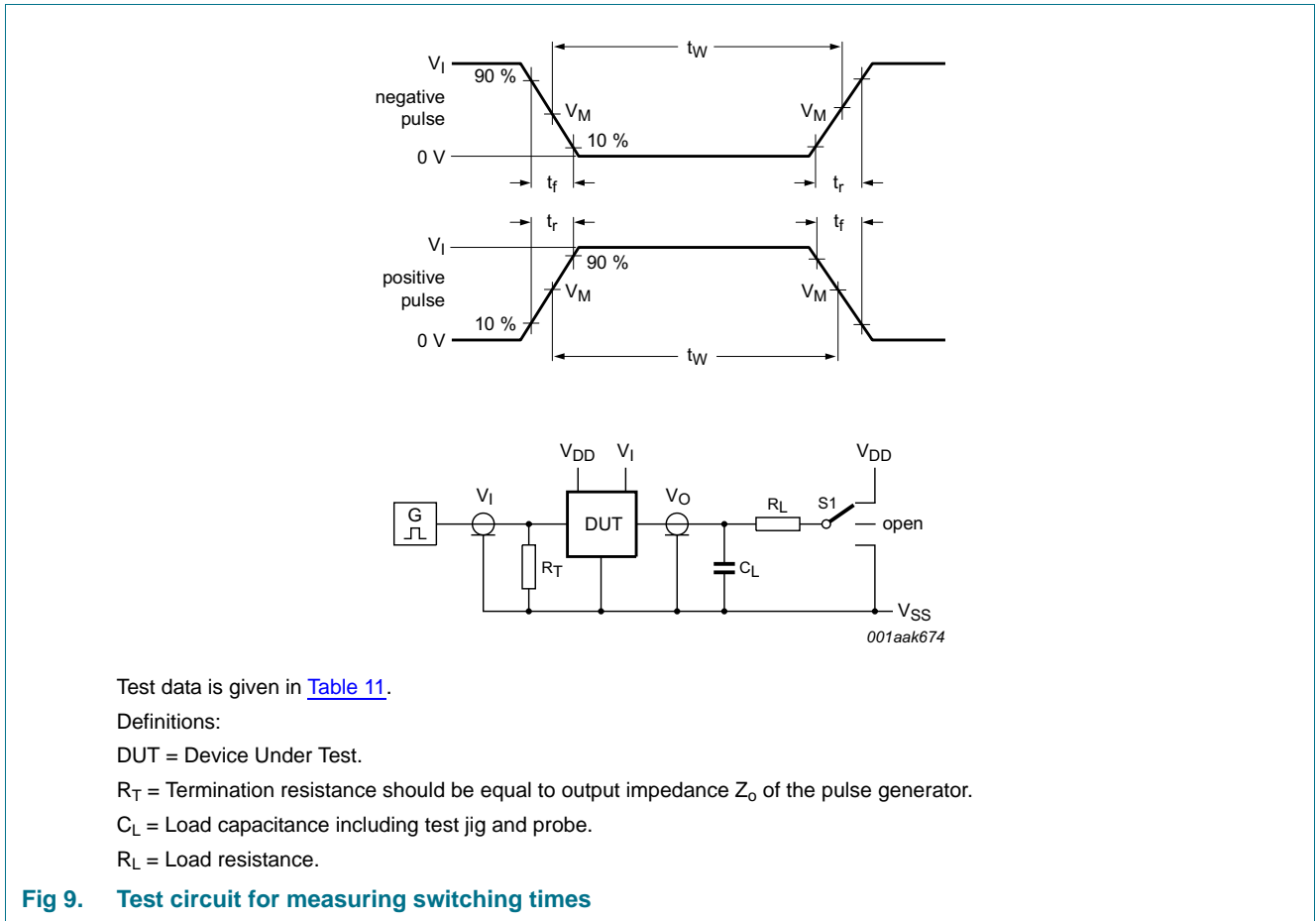

Table 11. Test data

Supply voltage	Input		Load		S1 position		
$V_{DD}$	$V_I$	$t_r, t_f$	$C_L$	$R_L$	$t_{PHL}, t_{PLH}$	$t_{PZH}, t_{PHZ}$	$t_{PZL}, t_{PLZ}$
5 V to 15 V	0 V or $V_{DD}$	$\leq 20$ ns	50 pF	10 k $\Omega$	$V_{SS}$	$V_{SS}$	$V_{DD}$

## 11.2 Additional dynamic parameters

Table 12. Additional dynamic characteristics

$V_{SS} = 0$  V;  $T_{amb} = 25$  °C.

Symbol	Parameter	Conditions	$V_{DD}$	Typ	Max	Unit	
THD	total harmonic distortion	see <a href="#">Figure 10</a> ; $R_L = 10$ k $\Omega$ ; $C_L = 15$ pF; channel ON; $V_I = 0.5V_{DD}$ (p-p); $f_i = 1$ kHz	5 V	<a href="#">[1]</a>	-	-	%
			10 V	<a href="#">[1]</a>	0.08	-	%
			15 V	<a href="#">[1]</a>	0.04	-	%
$V_{ct}$	crosstalk voltage	nE input to switch; see <a href="#">Figure 11</a> ; $R_L = 10$ k $\Omega$ ; $C_L = 15$ pF; nE = $V_{DD}$ (square-wave)	10 V	50	-	mV	

Table 12. Additional dynamic characteristics ...continued

$V_{SS} = 0\text{ V}$ ;  $T_{amb} = 25\text{ }^{\circ}\text{C}$ .

Symbol	Parameter	Conditions	$V_{DD}$	Typ	Max	Unit
Xtalk	crosstalk	between switches; see Figure 12; $f_i = 1\text{ MHz}$ ; $R_L = 1\text{ k}\Omega$ ; $V_I = 0.5V_{DD}$ (p-p)	10 V	[1]	-50	dB
$\alpha_{iso}$	isolation (OFF-state)	see Figure 13; $f_i = 1\text{ MHz}$ ; $R_L = 1\text{ k}\Omega$ ; $C_L = 5\text{ pF}$ ; $V_I = 0.5V_{DD}$ (p-p)	10 V	[1]	-50	dB
$f_{(-3dB)}$	-3 dB frequency response	see Figure 14; $R_L = 1\text{ k}\Omega$ ; $C_L = 5\text{ pF}$ ; $V_I = 0.5V_{DD}$ (p-p)	10 V	[1]	90	MHz

[1]  $f_i$  is biased at  $0.5V_{DD}$ .

11.2.1 Test circuits

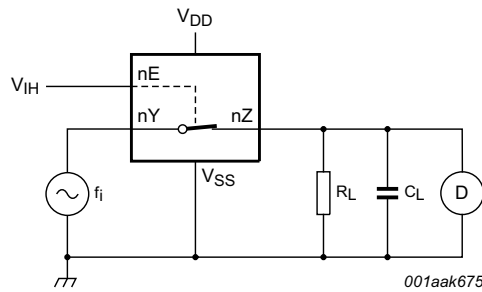
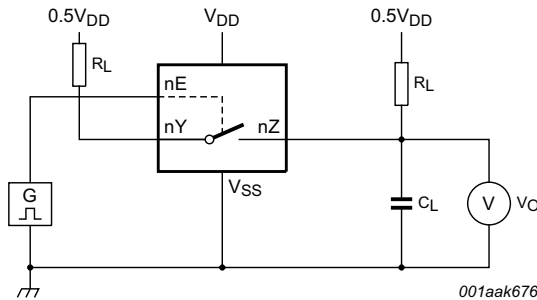
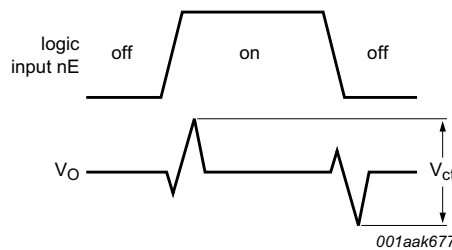

Fig 10. Test circuit for measuring total harmonic distortion



a. Test circuit



b. Input and output pulse definitions

Fig 11. Test circuit for measuring crosstalk voltage between digital input and switch

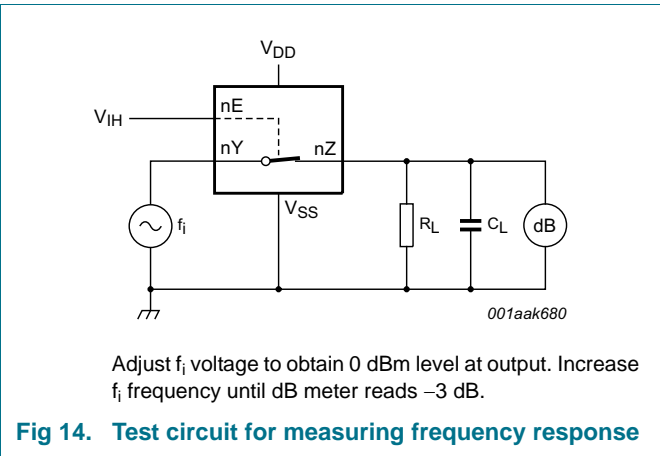
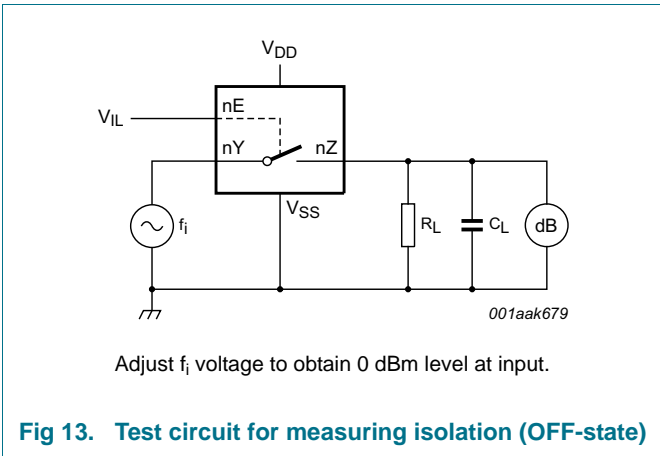
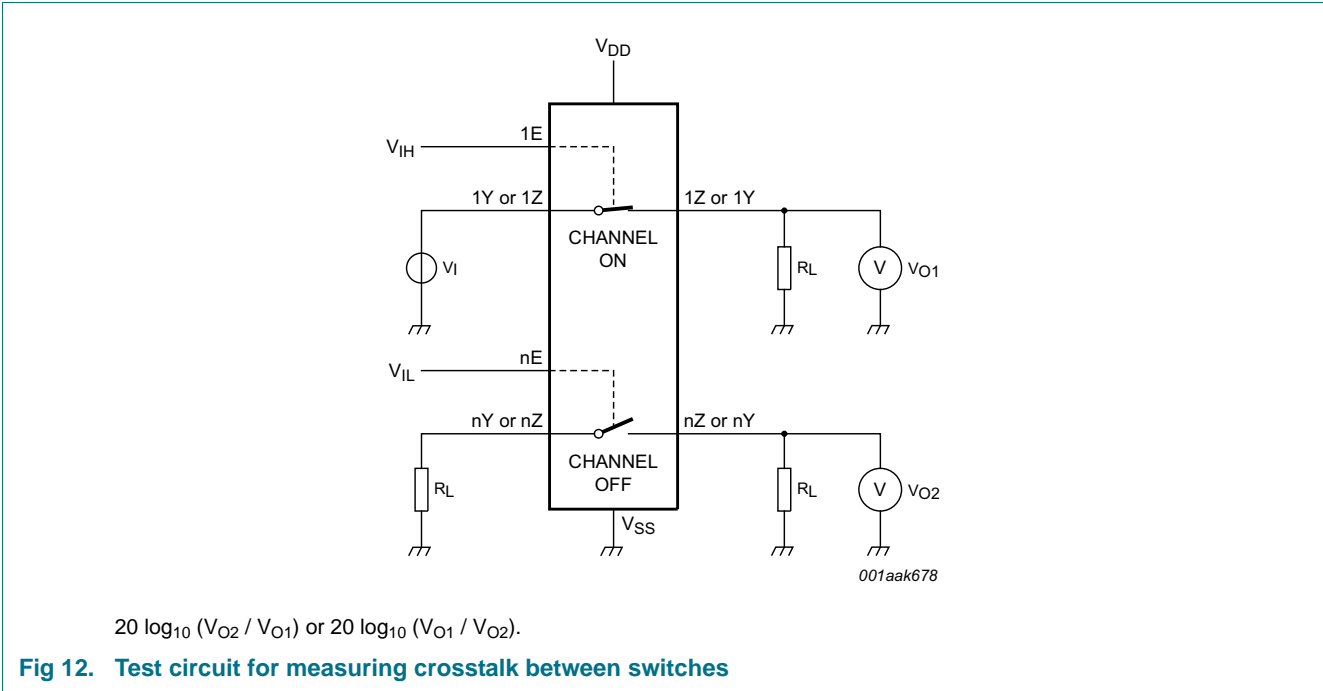

12. Package outline

SO14: plastic small outline package; 14 leads; body width 3.9 mm

SOT108-1

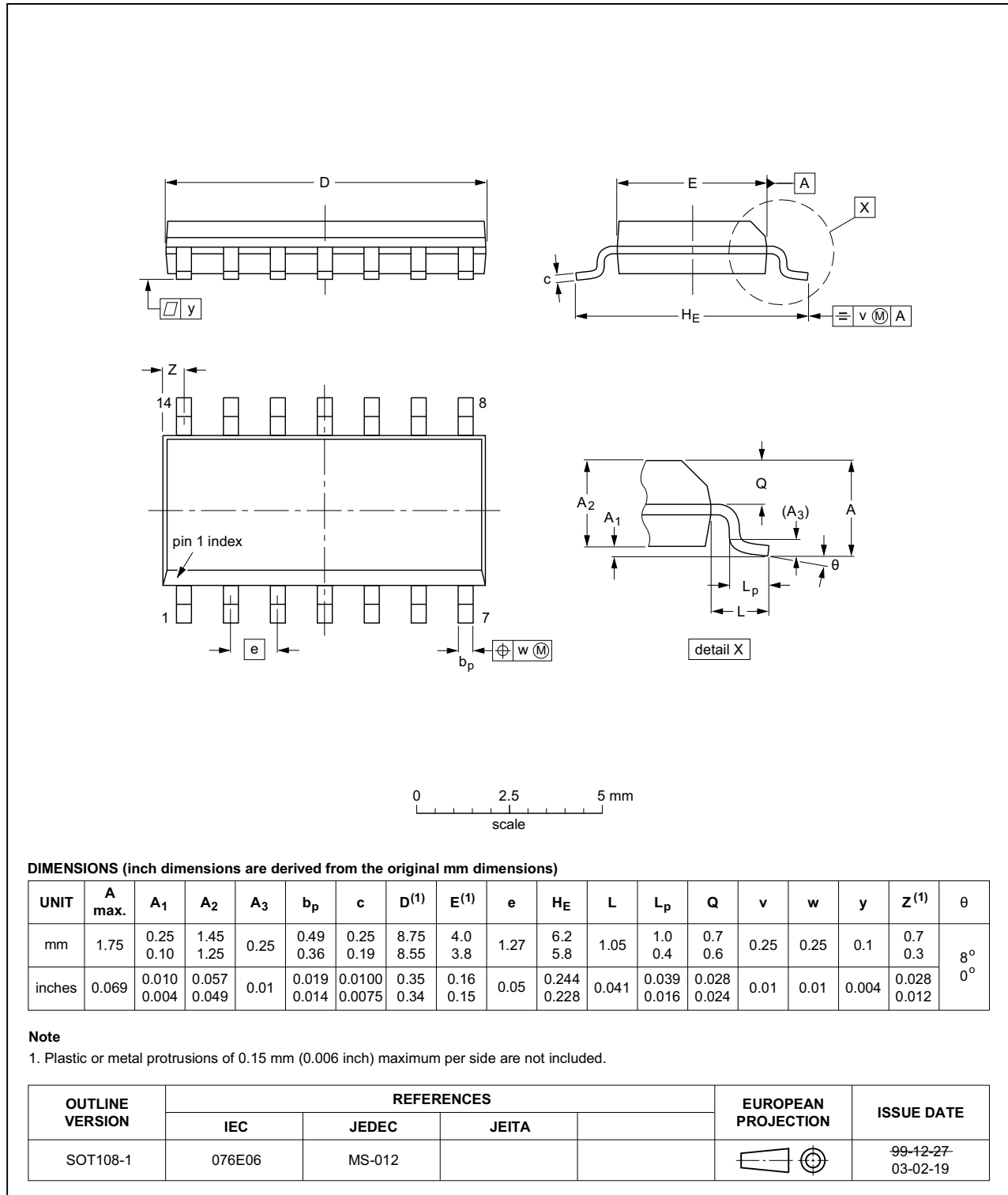

Fig 15. Package outline SOT108-1 (SO14)

## 13. Abbreviations

Table 13. Abbreviations

Acronym	Description
DUT	Device Under Test

## 14. Revision history

Table 14. Revision history

Document ID	Release date	Data sheet status	Change notice	Supersedes
HEF4016B v.4	20161024	Product data sheet	-	HEF4016B_CNV v.3
Modifications:	<ul style="list-style-type: none"><li>The format of this data sheet has been redesigned to comply with the new identity guidelines of NXP Semiconductors.</li><li>Legal texts have been adapted to the new company name where appropriate.</li></ul>			
HEF4016B_CNV v.3	19950101	Product specification	-	HEF4016B_CNV v.2
HEF4016B_CNV v.2	19950101	Product specification	-	-

## 15. Legal information

### 15.1 Data sheet status

Document status <sup>[1][2]</sup>	Product status <sup>[3]</sup>	Definition
Objective [short] data sheet	Development	This document contains data from the objective specification for product development.
Preliminary [short] data sheet	Qualification	This document contains data from the preliminary specification.
Product [short] data sheet	Production	This document contains the product specification.

[1] Please consult the most recently issued document before initiating or completing a design.

[2] The term 'short data sheet' is explained in section "Definitions".

[3] The product status of device(s) described in this document may have changed since this document was published and may differ in case of multiple devices. The latest product status information is available on the Internet at URL <http://www.nxp.com>.

### 15.2 Definitions

**Draft** — The document is a draft version only. The content is still under internal review and subject to formal approval, which may result in modifications or additions. NXP Semiconductors does not give any representations or warranties as to the accuracy or completeness of information included herein and shall have no liability for the consequences of use of such information.

**Short data sheet** — A short data sheet is an extract from a full data sheet with the same product type number(s) and title. A short data sheet is intended for quick reference only and should not be relied upon to contain detailed and full information. For detailed and full information see the relevant full data sheet, which is available on request via the local NXP Semiconductors sales office. In case of any inconsistency or conflict with the short data sheet, the full data sheet shall prevail.

**Product specification** — The information and data provided in a Product data sheet shall define the specification of the product as agreed between NXP Semiconductors and its customer, unless NXP Semiconductors and customer have explicitly agreed otherwise in writing. In no event however, shall an agreement be valid in which the NXP Semiconductors product is deemed to offer functions and qualities beyond those described in the Product data sheet.

### 15.3 Disclaimers

**Limited warranty and liability** — Information in this document is believed to be accurate and reliable. However, NXP Semiconductors does not give any representations or warranties, expressed or implied, as to the accuracy or completeness of such information and shall have no liability for the consequences of use of such information. NXP Semiconductors takes no responsibility for the content in this document if provided by an information source outside of NXP Semiconductors.

In no event shall NXP Semiconductors be liable for any indirect, incidental, punitive, special or consequential damages (including - without limitation - lost profits, lost savings, business interruption, costs related to the removal or replacement of any products or rework charges) whether or not such damages are based on tort (including negligence), warranty, breach of contract or any other legal theory.

Notwithstanding any damages that customer might incur for any reason whatsoever, NXP Semiconductors' aggregate and cumulative liability towards customer for the products described herein shall be limited in accordance with the *Terms and conditions of commercial sale* of NXP Semiconductors.

**Right to make changes** — NXP Semiconductors reserves the right to make changes to information published in this document, including without limitation specifications and product descriptions, at any time and without notice. This document supersedes and replaces all information supplied prior to the publication hereof.

**Suitability for use** — NXP Semiconductors products are not designed, authorized or warranted to be suitable for use in life support, life-critical or safety-critical systems or equipment, nor in applications where failure or malfunction of an NXP Semiconductors product can reasonably be expected to result in personal injury, death or severe property or environmental damage. NXP Semiconductors and its suppliers accept no liability for inclusion and/or use of NXP Semiconductors products in such equipment or applications and therefore such inclusion and/or use is at the customer's own risk.

**Applications** — Applications that are described herein for any of these products are for illustrative purposes only. NXP Semiconductors makes no representation or warranty that such applications will be suitable for the specified use without further testing or modification.

Customers are responsible for the design and operation of their applications and products using NXP Semiconductors products, and NXP Semiconductors accepts no liability for any assistance with applications or customer product design. It is customer's sole responsibility to determine whether the NXP Semiconductors product is suitable and fit for the customer's applications and products planned, as well as for the planned application and use of customer's third party customer(s). Customers should provide appropriate design and operating safeguards to minimize the risks associated with their applications and products.

NXP Semiconductors does not accept any liability related to any default, damage, costs or problem which is based on any weakness or default in the customer's applications or products, or the application or use by customer's third party customer(s). Customer is responsible for doing all necessary testing for the customer's applications and products using NXP Semiconductors products in order to avoid a default of the applications and the products or of the application or use by customer's third party customer(s). NXP does not accept any liability in this respect.

**Limiting values** — Stress above one or more limiting values (as defined in the Absolute Maximum Ratings System of IEC 60134) will cause permanent damage to the device. Limiting values are stress ratings only and (proper) operation of the device at these or any other conditions above those given in the Recommended operating conditions section (if present) or the Characteristics sections of this document is not warranted. Constant or repeated exposure to limiting values will permanently and irreversibly affect the quality and reliability of the device.

**Terms and conditions of commercial sale** — NXP Semiconductors products are sold subject to the general terms and conditions of commercial sale, as published at <http://www.nxp.com/profile/terms>, unless otherwise agreed in a valid written individual agreement. In case an individual agreement is concluded only the terms and conditions of the respective agreement shall apply. NXP Semiconductors hereby expressly objects to applying the customer's general terms and conditions with regard to the purchase of NXP Semiconductors products by customer.

**No offer to sell or license** — Nothing in this document may be interpreted or construed as an offer to sell products that is open for acceptance or the grant, conveyance or implication of any license under any copyrights, patents or other industrial or intellectual property rights.

**Export control** — This document as well as the item(s) described herein may be subject to export control regulations. Export might require a prior authorization from competent authorities.

**Non-automotive qualified products** — Unless this data sheet expressly states that this specific NXP Semiconductors product is automotive qualified, the product is not suitable for automotive use. It is neither qualified nor tested in accordance with automotive testing or application requirements. NXP Semiconductors accepts no liability for inclusion and/or use of non-automotive qualified products in automotive equipment or applications.

In the event that customer uses the product for design-in and use in automotive applications to automotive specifications and standards, customer (a) shall use the product without NXP Semiconductors' warranty of the product for such automotive applications, use and specifications, and (b) whenever customer uses the product for automotive applications beyond

NXP Semiconductors' specifications such use shall be solely at customer's own risk, and (c) customer fully indemnifies NXP Semiconductors for any liability, damages or failed product claims resulting from customer design and use of the product for automotive applications beyond NXP Semiconductors' standard warranty and NXP Semiconductors' product specifications.

**Translations** — A non-English (translated) version of a document is for reference only. The English version shall prevail in case of any discrepancy between the translated and English versions.

## 15.4 Trademarks

Notice: All referenced brands, product names, service names and trademarks are the property of their respective owners.

## 16. Contact information

For more information, please visit: <http://www.nxp.com>

For sales office addresses, please send an email to: [salesaddresses@nxp.com](mailto:salesaddresses@nxp.com)

17. Contents

1 General description . . . . . 1

2 Features and benefits . . . . . 1

3 Applications . . . . . 1

4 Ordering information . . . . . 1

5 Functional diagram . . . . . 2

6 Pinning information . . . . . 2

6.1 Pinning . . . . . 2

6.2 Pin description . . . . . 2

7 Functional description . . . . . 3

8 Limiting values . . . . . 3

9 Recommended operating conditions . . . . . 3

10 Static characteristics . . . . . 4

10.1 Test circuit . . . . . 4

10.2 ON resistance . . . . . 5

10.2.1 ON resistance waveform and test circuit . . . . . 5

11 Dynamic characteristics . . . . . 6

11.1 Waveforms and test circuit . . . . . 7

11.2 Additional dynamic parameters . . . . . 8

11.2.1 Test circuits . . . . . 9

12 Package outline . . . . . 11

13 Abbreviations . . . . . 12

14 Revision history . . . . . 12

15 Legal information . . . . . 13

15.1 Data sheet status . . . . . 13

15.2 Definitions . . . . . 13

15.3 Disclaimers . . . . . 13

15.4 Trademarks . . . . . 14

16 Contact information . . . . . 14

17 Contents . . . . . 15

Please be aware that important notices concerning this document and the product(s) described herein, have been included in section 'Legal information'.

© NXP Semiconductors N.V. 2016. All rights reserved.

For more information, please visit: <http://www.nxp.com>  
 For sales office addresses, please send an email to: [salesaddresses@nxp.com](mailto:salesaddresses@nxp.com)

Date of release: 24 October 2016  
 Document identifier: HEF4016B