

**SCHOTTKY BARRIER RECTIFIER**

VOLTAGE RANGE 20 to 40 Volts CURRENT 1.0 Ampere

**Features**

- Metal silicon junction, majority carrier conduction
- Guarding for overvoltage protection
- Low power loss, high efficiency
- High current capability
- low forward voltage drop
- High surge capability
- For use in low voltage, high frequency inverters, free wheeling, and polarity protection applications

**PINNING**

PIN	DESCRIPTION
1	Cathode
2	Anode

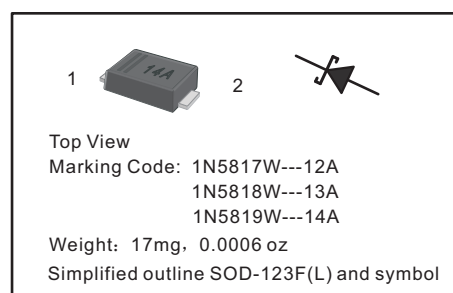

**Maximum Ratings and Electrical characteristics**

Ratings at 25 °C ambient temperature unless otherwise specified.

Parameter	Symbols	1N5817W	1N5818W	1N5819W	Units
Maximum Repetitive Peak Reverse Voltage	$V_{RRM}$	20	30	40	V
Maximum RMS voltage	$V_{RMS}$	14	21	28	V
Maximum DC Blocking Voltage	$V_{DC}$	20	30	40	V
Maximum Average Forward Rectified Current 0.375" (9.5 mm) Lead Length at $T_L = 90^\circ\text{C}$	$I_{F(AV)}$	1			A
Peak Forward Surge Current, 8.3ms Single Half Sine-wave Superimposed On Rated Load (JEDEC method) at $T_L = 70^\circ\text{C}$	$I_{FSM}$	25			A
Typical Current Squared Time	$I^2T$	2.59			A <sup>2</sup> S
Maximum Instantaneous Forward Voltage at 1 A Maximum Instantaneous Forward Voltage at 3.1 A	$V_F$	0.45 0.75	0.55 0.875	0.6 0.9	V
Maximum Instantaneous Reverse Current at $T_A = 25^\circ\text{C}$ Rated DC Reverse Voltage $T_A = 100^\circ\text{C}$	$I_R$	1 10			mA
Typical Thermal Resistance	$R_{\theta JA}$ $R_{\theta JL}$	50 15			$^\circ\text{C}/\text{W}$
Typical Junction Capacitance	$C_j$	110			pF
Storage and Operating Junction Temperature Range	$T_j, T_{stg}$	-55 ~ +125			$^\circ\text{C}$

# RATING AND CHARACTERISTICS CURVES ( 1N5817W THRU 1N5819W )

**Fig.1 Forward Current Derating Curve**

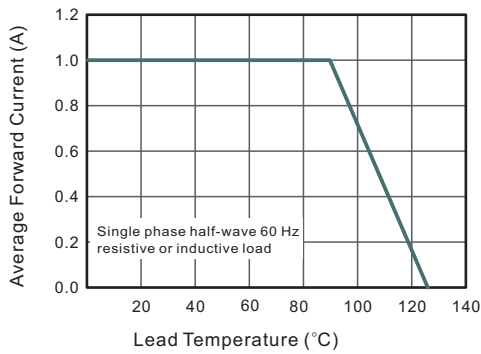

**Fig.2 Typical Reverse Characteristics**

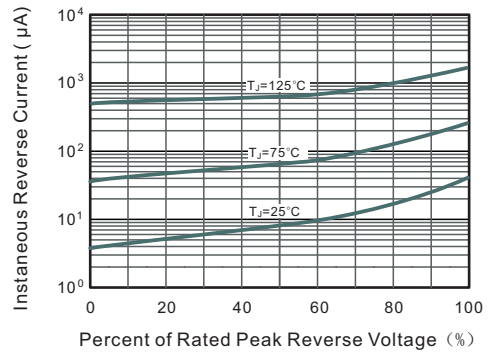

**Fig.3 Typical Forward Characteristic**

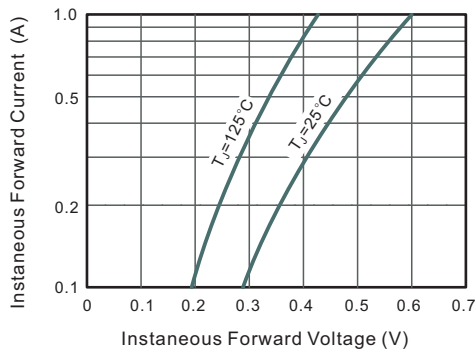

**Fig.4 Typical Junction Capacitance**

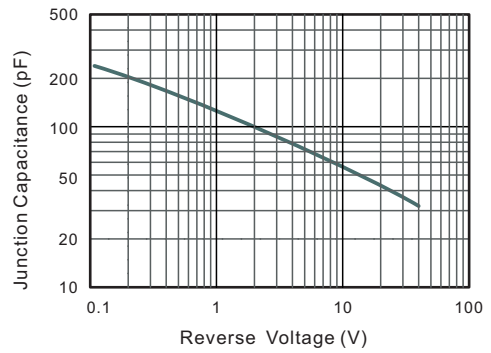

**Fig.5 Maximum Non-Repetitive Peak Forward Surge Current**

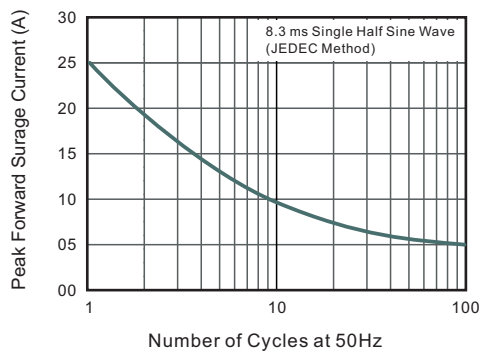

**Fig.6- Typical Transient Thermal Impedance**

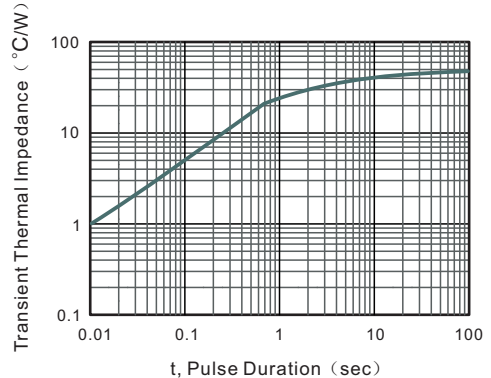

# PACKAGE OUTLINE

Plastic surface mounted package; 2 leads

SOD123F(L)

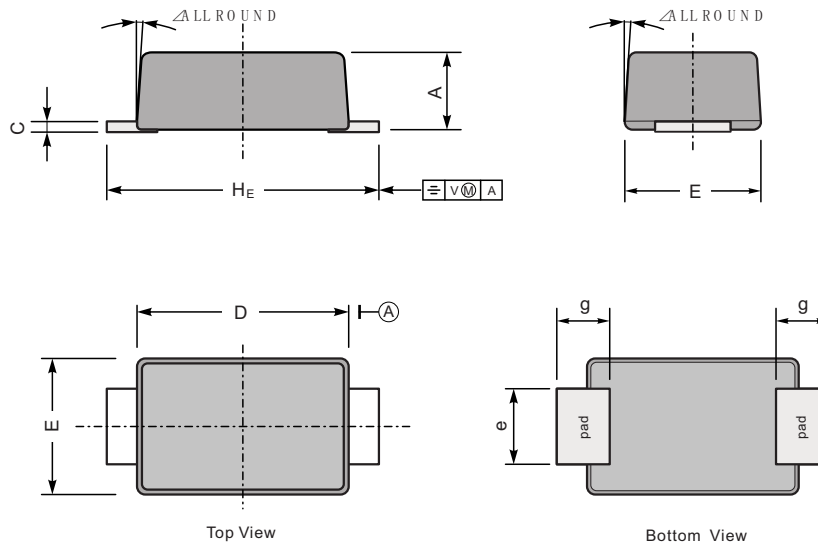

UNIT		A	C	D	E	e	g	$H_E$	$\angle$
mm	max	1.1	0.20	2.9	1.9	1.1	0.9	3.8	7°
	min	0.9	0.12	2.6	1.7	0.8	0.7	3.5	
mil	max	43	7.9	114	75	43	35	150	
	min	35	4.7	102	67	31	28	138	

## The recommended mounting pad size

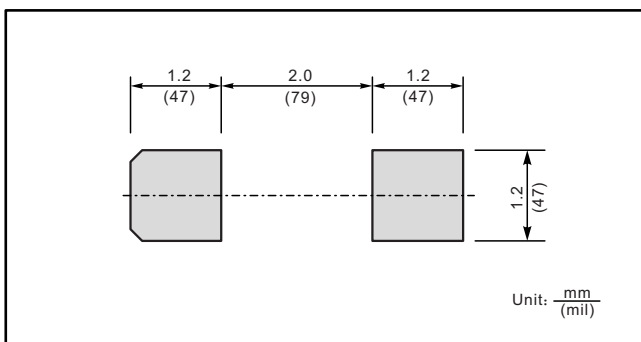

## Marking

Type number	Marking code
1N5817W	12A
1N5818W	13A
1N5819W	14A

• Recommended condition of flow soldering

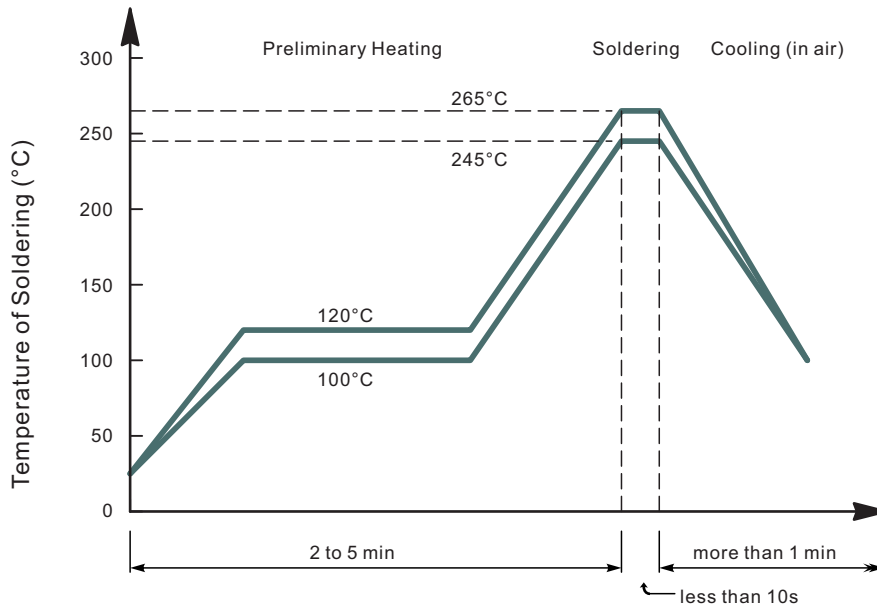

• Recommended condition of reflow soldering

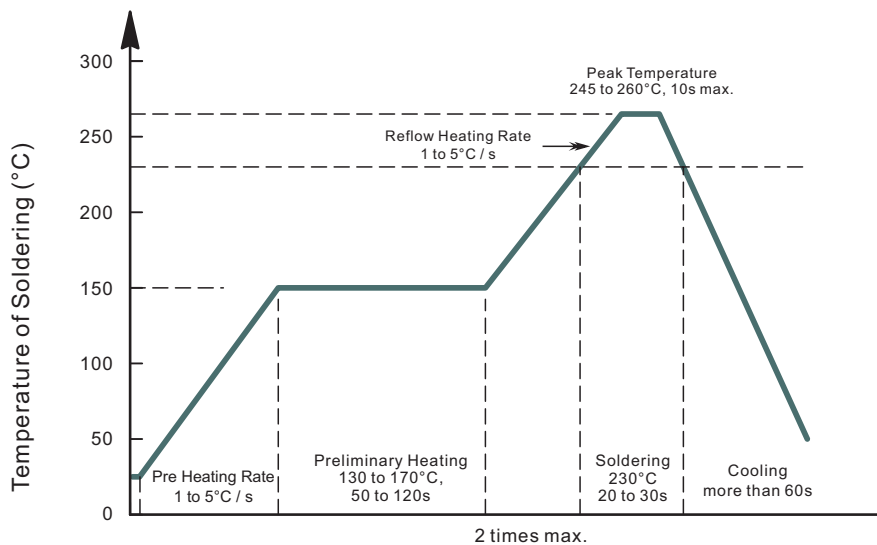

Recommended peak temperature is over 245 °C. If peak temperature is below 245 °C, you may adjust the following parameters; time length of peak temperature (longer), time length of soldering (longer), thickness of solder paste (thicker)

• Condition of hand soldering

Temperature: 320°C  
 Time: 3s max.  
 Times: one time

• Remark:

Lead free solder paste (96.5Sn/3.0Ag/0.5Cu)

**1. The method of packaging and dimension are shown as below figure. (Dimension in mm)**

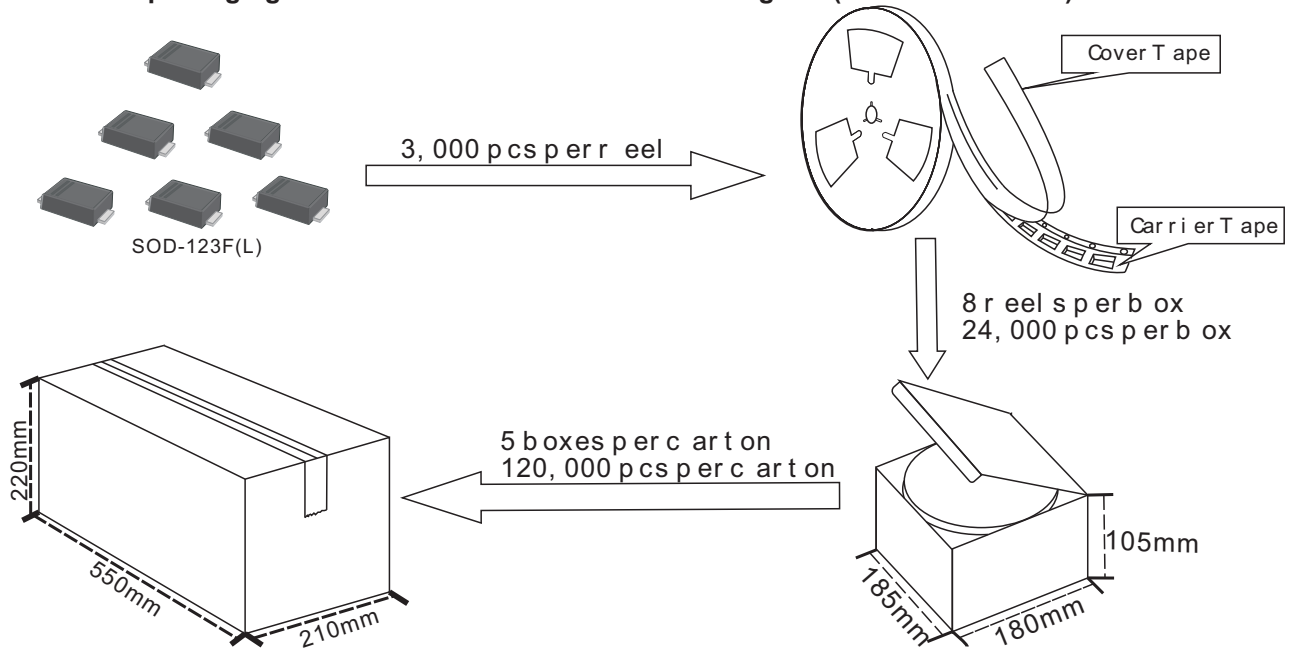

**2. Tape and reel data (Units: mm)**

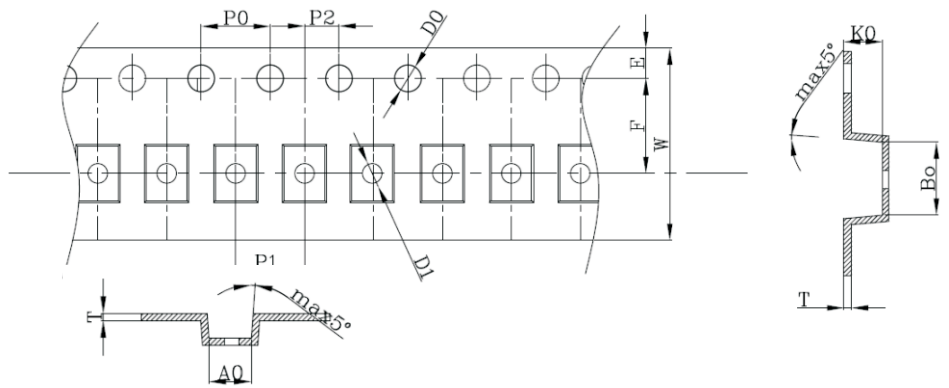
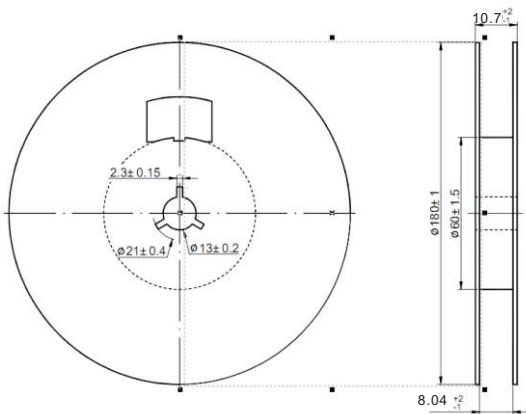

SYMBOL	A0	B0	K0	P0	P1	P2
SPEC	2.05±0.10	3.9±0.10	1.28±0.10	4.00±0.10	4.00±0.10	2.00±0.05
SYMBOL	T	E	F	D0	D1	W
SPEC	0.25±0.02	1.75±0.10	3.50±0.05	1.55±0.05	1.1±0.1	8.00±0.3

## DISCLAIMER NOTICE

Rectron Inc reserves the right to make changes without notice to any product specification herein, to make corrections, modifications, enhancements or other changes. Rectron Inc or anyone on its behalf assumes no responsibility or liability for any errors or inaccuracies. Data sheet specifications and its information contained are intended to provide a product description only. "Typical" parameters which may be included on RECTRON data sheets and/ or specifications can and do vary in different applications and actual performance may vary over time. Rectron Inc does not assume any liability arising out of the application or use of any product or circuit.

Rectron products are not designed, intended or authorized for use in medical, life-saving implant or other applications intended for life-sustaining or other related applications where a failure or malfunction of component or circuitry may directly or indirectly cause injury or threaten a life without expressed written approval of Rectron Inc. Customers using or selling Rectron components for use in such applications do so at their own risk and shall agree to fully indemnify Rectron Inc and its subsidiaries harmless against all claims, damages and expenditures.