

Rochester Electronics Manufactured Components

Rochester branded components are manufactured using either die/wafers purchased from the original suppliers or Rochester wafers recreated from the original IP. All recreations are done with the approval of the OCM.

Parts are tested using original factory test programs or Rochester developed test solutions to guarantee product meets or exceed the OCM data sheet.

Quality Overview

- ISO-9001
- AS9120 certification
- Qualified Manufacturers List (QML) MIL-PRF-35835
 - Class Q Military
 - Class V Space Level
- Qualified Suppliers List of Distributors (QSLD)
 - Rochester is a critical supplier to DLA and meets all industry and DLA standards.

Rochester Electronics, LLC is committed to supplying products that satisfy customer expectations for quality and are equal to those originally supplied by industry manufacturers.

The original manufacturer's datasheet accompanying this document reflects the performance and specifications of the Rochester manufactured version of this device. Rochester Electronics guarantees the performance of its semiconductor products to the original OEM specifications. 'Typical' values are for reference purposes only. Certain minimum or maximum ratings may be based on product characterization, design, simulation, or sample testing.

1 Overview

Features

- Quad switch driver
- Free configureable as bridge or quad-switch
- Optimized for DC motor management applications
- Ultra low $R_{DS\ ON}$ @ 25 °C:
 High-side switch: typ. 34 mΩ,
 Low-side switch: typ. 15 mΩ
- High peak current capability of typ. 44 A @ 25 °C
- Low quiescent current of typ. 15 μA @ 25 °C
- SMD-Power-Package, optimized for small size and thermal performance
- Load and GND-short-circuit-protected
- Operates up to 36 V
- 2-Bit status flag diagnosis
- Overtemperature shut down with hysteresis
- Short-circuit detection and diagnosis
- Open-load detection and diagnosis
- C-MOS compatible inputs
- Internal clamp diodes
- Isolated sources for external current sensing
- Over- and under-voltage detection with hysteresis
- Fast low-side switches for PWM

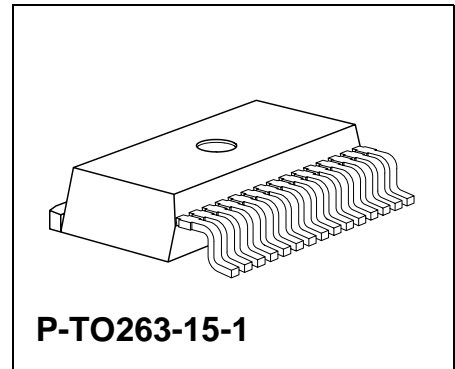

Type	Ordering Code	Package
BTS 780 GP	Q67006-A9320	P-TO263-15-1

Description

The **BTS 780 GP** is part of the **TrilithIC** family containing one double high-side switch and two low-side switches in **one P-TO263-15-1** package.

**“Silicon instead of heatsink”
becomes true**

The ultra low $R_{DS\ ON}$ of this device avoids power dissipation. It saves costs in mechanical construction and mounting and increases the efficiency.

The high-side switches are produced in the **SMART SIPMOS®** technology. They are fully protected and contain the signal conditioning circuitry for diagnosis (the comparable standard high-side product is the **BTS 734L1**).

For minimized $R_{DS\ ON}$ the two low-side switches are produced in **S-FET** logic level technology (the comparable standard product is the **BUZ 100SL**).

Each drain of these three chips is mounted on separated leadframes (see **Figure 1**). The sources of all four power transistors are connected to separate pins.

So the **BTS 780 GP** can be used in H-Bridge configuration as well as in any other switch configuration.

Moreover, it is possible to add current sense resistors.

All these features open a broad range of automotive and industrial applications.

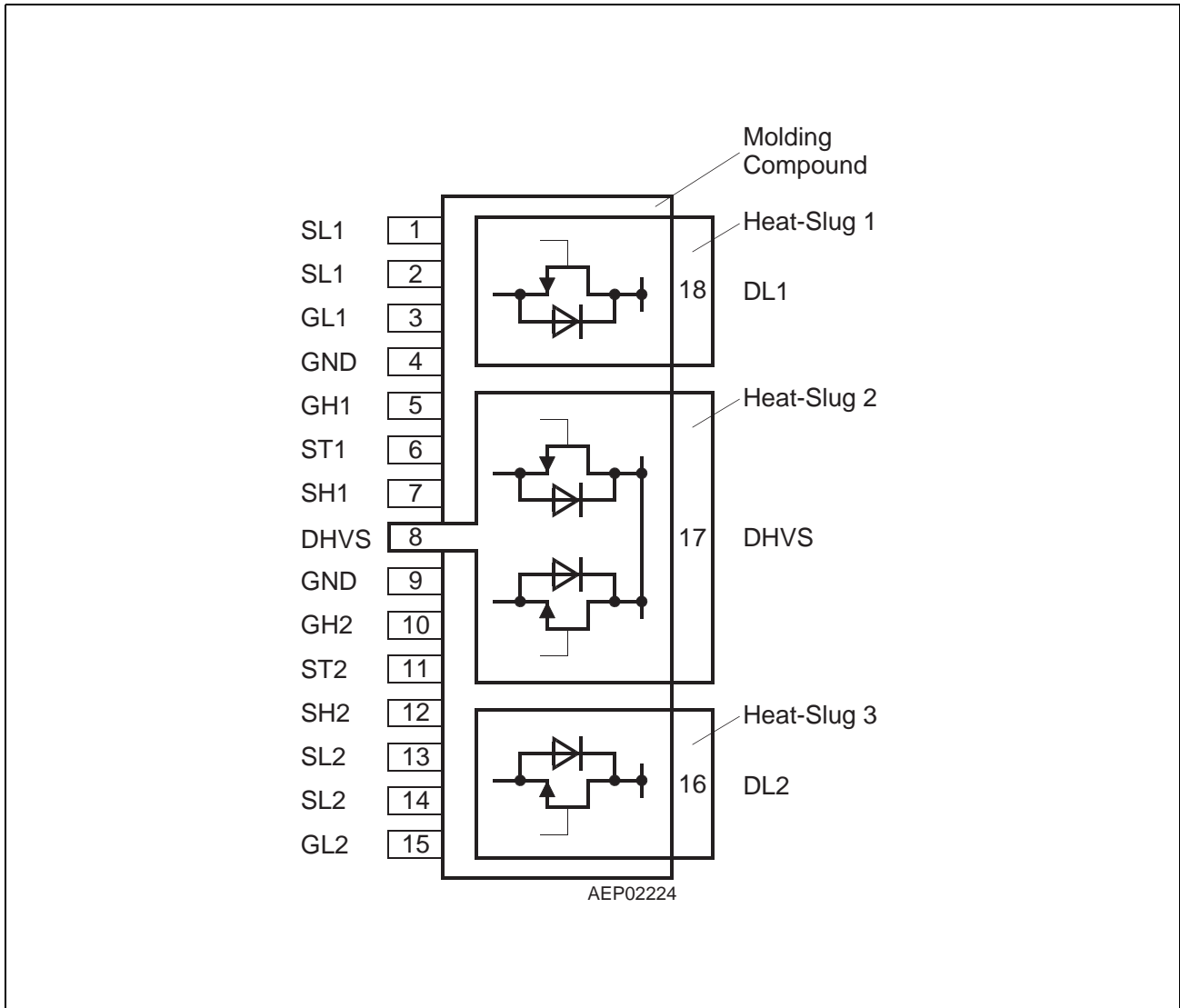

Figure 1 Pin Configuration (top view)

Pin Definitions and Functions

Pin No.	Symbol	Function
1, 2	SL1	Source of low-side switch 1
3	GL1	Gate of low-side switch 1
4, 9	GND	Ground
5	GH1	Gate of high-side switch 1
6	ST1	Status of high-side switch 1; open Drain output
7	SH1	Source of high-side switch 1
8, 17	DHVS	Drain of high-side switches and power supply voltage Heat-Slug 2 or Heat-Dissipator
10	GH2	Gate of high-side switch 2
11	ST2	Status of high-side switch 2; open Drain output
12	SH2	Source of high-side switch 2
13, 14	SL2	Source of low-side switch 2
15	GL2	Gate of low-side switch 2
16	DL2	Drain of low-side switch 2 Heat-Slug 3 or Heat-Dissipator
18	DL1	Drain of low-side switch 1 Heat-Slug 1 or Heat-Dissipator

Bold type: Pin needs power wiring.

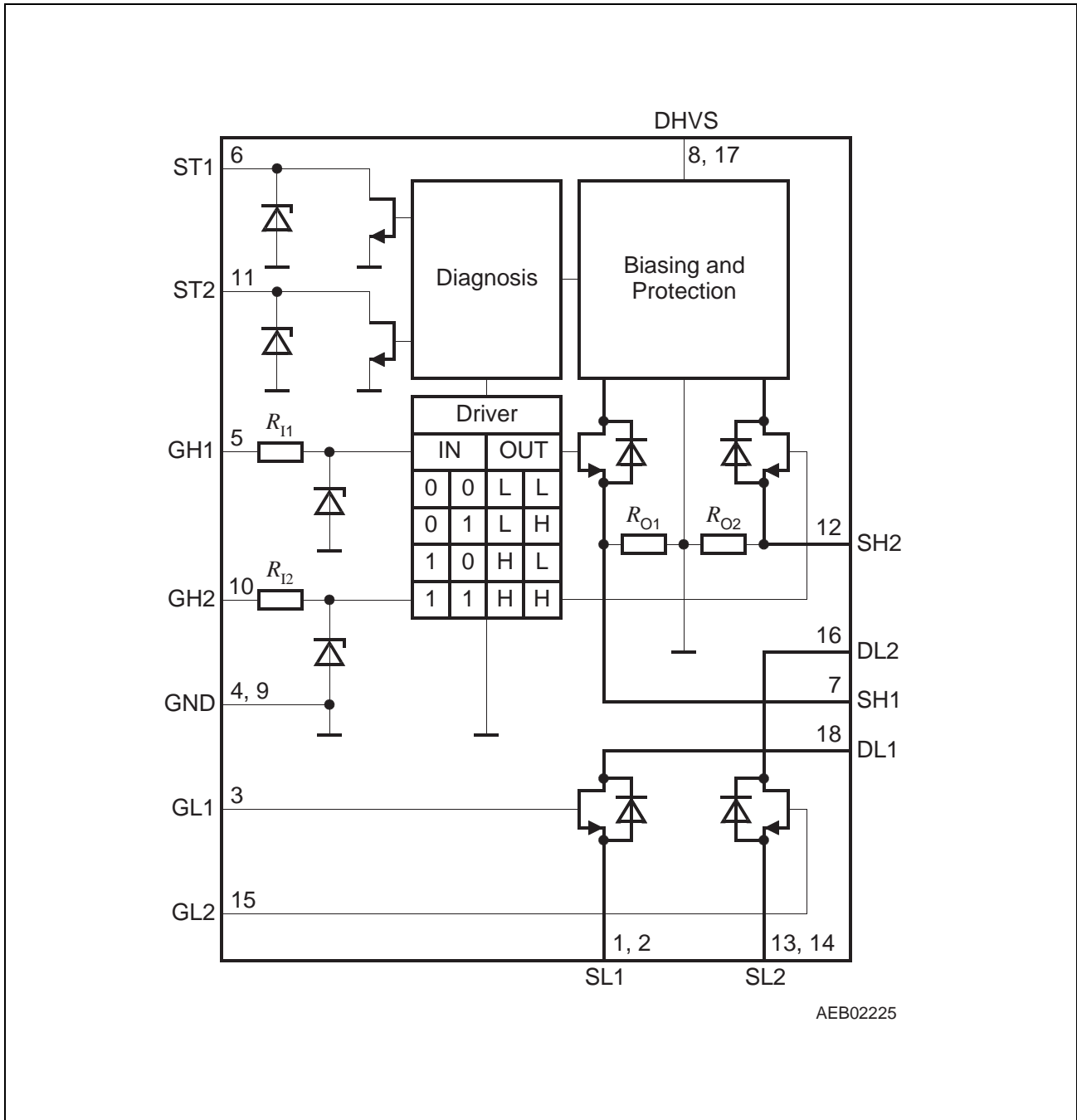

Figure 2 Block Diagram

2 Circuit Description

2.1 Input Circuit

The control inputs GH1,2 consist of TTL/CMOS compatible Schmitt-Triggers with hysteresis. Buffer amplifiers are driven by these stages and convert the logic signal into the form necessary for driving the power output stages. The inputs are protected by ESD clamp-diodes.

The inputs GL1 and GL2 are connected to a standard N-channel logic level power-MOS gate.

2.2 Output Stages

The output stages consist of an ultra low $R_{DS\ ON}$ Power-MOS H-Bridge. Protective circuits make the outputs short-circuit proof to ground and load short-circuit proof. In H-bridge configuration, the D-MOS body-diodes can be used for freewheeling when commutating inductive loads. If the high-side switches are used as single switches, positive and negative voltage spikes which occur when driving inductive loads are limited by integrated power clamp diodes (c.f. **BTS 734L1** datasheet for a detailed description).

2.3 Short-Circuit Protection (valid only for the high-side switches)

The outputs are protected against

- output short circuit to ground, and
- overload (load short circuit).

An internal OP-Amp controls the Drain-Source-Voltage of the HS-Switches by comparing the DS-Voltage-drop with an internal reference voltage. Above this trippoint the OP-Amp reduces the output current depending on the junction temperature and the drop voltage.

In the case of an overloaded high-side switch the corresponding status output is set to low.

If the HS-Switches are in OFF-state-Condition internal resistors $R_{O1,2}$ from SH1,2 to GND pull the voltage at SH1,2 to low values. On each output pin SH1 and SH2 an output examiner circuit compares the output voltages with the internal reference voltage VEO. This results in switching the corresponding status output to low if the source voltage in OFF-Condition is higher than VEO. In H-Bridge condition this feature can be used to protect the low-side switches against short circuit to V_S during the OFF-period.

2.4 Overtemperature Protection (valid only for the high-side-switches)

The chip also incorporates an overtemperature protection circuit with hysteresis which switches off the output transistors and sets the status output to low.

2.5 Under-Voltage-Lockout (UVLO)

When V_S reaches the switch-on voltage $V_{UV\ ON}$ the IC becomes active with a hysteresis. The High-Side output transistors are switched off if the supply voltage V_S drops below the switch off value $V_{UV\ OFF}$.

2.6 Over-Voltage-Lockout (OVLO)

When V_S reaches the switch-off voltage $V_{OV\ OFF}$ the High-Side output transistors are switched off with a hysteresis. The IC becomes active if the supply voltage V_S drops below the switch-on value $V_{OV\ ON}$.

2.7 Open Load Detection

Open load is detected by current measurement in the High-Side switches during ON-condition. If the output current drops below an internally fixed level (open circuit detection current) the error flag is set with a delay.

2.8 Status Flag

The status flag outputs are open drain outputs with Zener-diodes which require pull-up resistors, c.f. the application circuit on **Page 16**. Various errors as listed in the table "Diagnosis" are detected by switching the open drain outputs ST1 or ST2 to low.

3 Truthtable and Diagnosis (valid only for the High-Side-Switches)

Flag	GH1	GH2	SH1	SH2	ST1	ST2	Remarks
	Inputs		Outputs				
Normal operation; identical with functional truth table	0	0	L	L	1	1	stand-by mode switch1 active switch2 active both switches active
	0	1	L	H	1	1	
	1	0	H	L	1	1	
	1	1	H	H	1	1	
Open load at high-side switch1	0	0	Z	L	1	1	detected
	0	1	Z	H	1	1	
Open load at high-side switch2	1	X	H	X	0	1	
	0	0	L	Z	1	1	
	1	0	H	Z	1	1	
Short circuit to DHVS at high-side switch1	X	1	X	H	1	0	detected
	0	0	H	L	0	1	detected
Short circuit to DHVS at high-side switch2	0	1	H	H	1	1	detected
	1	X	H	X	1	1	
	0	0	L	H	1	0	
Overtemperature high-side switch1	1	0	H	H	1	1	detected
	1	0	H	H	1	1	
	X	1	X	H	1	1	
Overtemperature high-side switch2	0	X	L	X	1	1	detected
	1	X	L	X	0	1	
Overtemperature both high-side switch	X	0	X	L	1	1	detected
	X	1	X	L	1	0	
	0	0	L	L	1	1	
Over- and Under-Voltage	X	1	L	L	0	0	detected
	1	X	L	L	0	0	detected
Over- and Under-Voltage	X	X	L	L	1	1	not detected

Inputs:

0 = Logic LOW

1 = Logic HIGH

X = don't care

Outputs:

Z = Output in tristate condition

L = Output in sink condition

H = Output in source condition

X = Voltage level undefined

Status:

1 = No error

0 = Error

4 Characteristics

4.1 Absolute Maximum Ratings

$-40\text{ °C} < T_j < 150\text{ °C}$

Parameter	Symbol	Limit Values		Unit	Remarks
		min.	max.		

High-Side-Switches (Pins DHVS, GH1,2 and SH1,2)

Supply voltage	V_S	- 0.3	43	V	-
HS-drain current	I_{DHS}	- 30	*	A	* internally limited
HS-input current	I_{GH}	- 2	2	mA	Pin GH1 and GH2
HS-input voltage	V_{GH}	- 10	16	V	Pin GH1 and GH2

Status Output ST

Status Output current	I_{ST}	- 5	5	mA	Pin ST1 and ST2
-----------------------	----------	-----	---	----	-----------------

Low-Side-Switches (Pins DL1,2, GL1,2 and SL1,2)

Break-down voltage	$V_{(BR)DSS}$	50	-	V	$V_{GS} = 0\text{ V}; I_D \leq 1\text{ mA}$
LS-drain current	I_{DLS}	-	30	A	-
LS-drain current	I_{DLS}	-	50	A	$t < 1\text{ ms}; v < 0.1$
LS-input voltage	V_{GL}	- 10	14	V	Pin GL1 and GL2

Temperatures

Junction temperature	T_j	- 40	150	°C	-
Storage temperature	T_{stg}	- 50	150	°C	-

Note: Maximum ratings are absolute ratings; exceeding any one of these values may cause irreversible damage to the integrated circuit.

4.2 Operating Range

Parameter	Symbol	Limit Values		Unit	Remarks
		min.	max.		
Supply voltage	V_S	$V_{UV\ OFF}$	36	V	After V_S rising above $V_{UV\ ON}$
Input voltages	V_{GH}	- 0.3	15	V	-
Input voltages	V_{GL}	- 9	13	V	-
Status output current	I_{ST}	0	2	mA	Pin ST1 or ST2
HS-junction temperature	T_{jHS}	- 40	150	°C	-
LS-junction temperature	T_{jLS}	- 40	150	°C	-

Note: In the operating range the functions given in the circuit description are fulfilled.

4.3 Thermal Resistances (one HS-LS-Path active)

Parameter	Symbol	Limit Values		Unit	Remarks
		min.	max.		
LS-junction case	R_{thjCLS}	-	0.5	K/W	measured to pin 16 or 18
HS-junction case	R_{thjCHS}	-	0.5	K/W	measured to pin 17
Junction ambient	R_{thja}	-	21	K/W	measured on test PCB ¹⁾

¹⁾ Device on 50 mm × 33 mm epoxy PCB with 6 cm² cooling-area in free air. C.f. PCB description on **Page 17**

4.4 Electrical Characteristics

$I_{SH1} = I_{SH2} = I_{SL1} = I_{SL2} = 0$ A; $-40\text{ °C} < T_j < 150\text{ °C}$; $8\text{ V} < V_S < 18\text{ V}$
 unless otherwise specified

Parameter	Symbol	Limit Values			Unit	Test Condition
		min.	typ.	max.		

Current Consumption

Quiescent current	I_S	–	15	30	μA	GH1 = GH2 = L $V_S = 13.2\text{ V}$ $T_j = 25\text{ °C}$
Quiescent current	I_S	–	–	42	μA	GH1 = GH2 = L $V_S = 13.2\text{ V}$
Supply current	I_S	–	2	4	mA	GH1 or GH2 = H
Supply current	I_S	–	4	8	mA	GH1 and GH2 = H

Under-Voltage-Lockout (UVLO)

Switch-ON voltage	$V_{UV\ ON}$	–	5.2	7	V	V_S increasing
Switch-OFF voltage	$V_{UV\ OFF}$	3.5	4.2	5.0	V	V_S decreasing
Switch ON/OFF hysteresis	$V_{UV\ HY}$	–	1	–	V	$V_{UV\ ON} - V_{UV\ OFF}$

Over-Voltage-Lockout (OVLO)

Switch-OFF voltage	$V_{OV\ OFF}$	36	–	43	V	V_S increasing
Switch-ON voltage	$V_{OV\ ON}$	35	–	–	V	V_S decreasing
Switch OFF/ON hysteresis	$V_{OV\ HY}$	–	0.5	–	V	$V_{OV\ OFF} - V_{OV\ ON}$

4.4 Electrical Characteristics (cont'd)

$I_{SH1} = I_{SH2} = I_{SL1} = I_{SL2} = 0 \text{ A}$; $-40 \text{ °C} < T_j < 150 \text{ °C}$; $8 \text{ V} < V_S < 18 \text{ V}$
unless otherwise specified

Parameter	Symbol	Limit Values			Unit	Test Condition
		min.	typ.	max.		

High-Side-Switches 1, 2

Static drain-source on-resistance	$R_{DS\ ON\ H}$	–	34	40	mΩ	$I_{SH} = 2 \text{ A}$ $T_j = 25 \text{ °C}$
Static drain-source on-resistance	$R_{DS\ ON\ H}$	–	–	75	mΩ	$I_{SH} = 2 \text{ A}$
Leakage current	I_{HSLK}	–	–	10	μA	$V_{GH} = V_{SH} = 0 \text{ V}$
Body-diode forward-voltage @ $I_{FH} = 2 \text{ A}$	V_{FH}	–	0.8	1.2	V	$T_j = -40 \text{ °C}$
	V_{FH}	–	0.7	1.1	V	$T_j = 25 \text{ °C}$
	V_{FH}	–	0.5	0.8	V	$T_j = 150 \text{ °C}$
Clamp-diode leakage-current ($I_{FH} + I_{SH}$)	I_{LKCL}	–	–	10	mA	$I_{FH} = 2 \text{ A}$

Short Circuit to GND

Initial peak SC current	I_{SCP}	47	55	66	A	$T_j = -40 \text{ °C}$
Initial peak SC current	I_{SCP}	35	44	54	A	$T_j = 25 \text{ °C}$
Initial peak SC current	I_{SCP}	29	36	45	A	$T_j = 85 \text{ °C}$
Initial peak SC current	I_{SCP}	21	27	34	A	$T_j = 150 \text{ °C}$

Short Circuit to V_S

OFF-state examiner-voltage	V_{EO}	2	3	4	V	$V_{GH} = 0 \text{ V}$
Output pull-down-resistor	R_O	4	10	30	kΩ	–

Open Circuit

Detection current	I_{OCD}	0.05	–	1.2	A	–
-------------------	-----------	------	---	-----	---	---

4.4 Electrical Characteristics (cont'd)

$I_{SH1} = I_{SH2} = I_{SL1} = I_{SL2} = 0 \text{ A}$; $-40 \text{ °C} < T_j < 150 \text{ °C}$; $8 \text{ V} < V_S < 18 \text{ V}$
unless otherwise specified

Parameter	Symbol	Limit Values			Unit	Test Condition
		min.	typ.	max.		

Switching Times

Switch-ON-time; to 90% V_{SH}	t_{ON}	–	130	300	μs	12 Ω resistive load $V_S = 13.2 \text{ V}$
Switch-OFF-time; to 10% V_{SH}	t_{OFF}	–	260	450	μs	12 Ω resistive load $V_S = 13.2 \text{ V}$

Control Inputs GH 1, 2

H-input voltage threshold	V_{GHH}	–	2.8	3.3	V	–
L-input voltage threshold	V_{GHL}	1.5	2.3	–	V	–
Input voltage hysteresis	V_{GHHY}	–	0.5	–	V	–
H-input current	I_{GHH}	20	50	90	μA	$V_{GH} = 5 \text{ V}$
L-input current	I_{GHL}	4	25	50	μA	$V_{GH} = 0.4 \text{ V}$
Input series resistance	R_I	2.5	4.2	6	k Ω	–
Zener limit voltage	V_{GHZ}	5.4	6.1	–	V	$I_{GH} = 1.6 \text{ mA}$

Low-Side-Switches 1, 2

Static drain-source on-resistance	$R_{DS\ ON\ L}$	–	15	20	m Ω	$I_{SL} = 2 \text{ A}$ $V_{GL} = 5 \text{ V}$ $T_j = 25 \text{ °C}$
Static drain-source on-resistance	$R_{DS\ ON\ L}$	–	–	35	m Ω	$I_{SH} = 2 \text{ A}$
Leakage current	I_{LKL}	–	< 1	100	μA	$V_{GL} = 0 \text{ V}$ $V_{DS} = 18 \text{ V}$
Body-diode forward-voltage @ $I_{FL} = 2 \text{ A}$	V_{FL}	–	0.8	1.2	V	$T_j = -40 \text{ °C}$
	V_{FL}	–	0.7	1.1	V	$T_j = 25 \text{ °C}$
	V_{FL}	–	0.5	0.8	V	$T_j = 150 \text{ °C}$

4.4 Electrical Characteristics (cont'd)

$I_{SH1} = I_{SH2} = I_{SL1} = I_{SL2} = 0$ A; -40 °C $< T_j < 150$ °C; 8 V $< V_S < 18$ V
unless otherwise specified

Parameter	Symbol	Limit Values			Unit	Test Condition
		min.	typ.	max.		

Control Inputs GL1, 2

Gate-threshold-voltage	$V_{GL(th)}$	0.6	1.6	2.4	V	$V_{GL} = V_{DSL}$ $I_{DL} = 130$ μ A
Transconductance	g_{fs}	–	5	–	S	$V_{DSL} = 20$ V; $I_{DL} = 20$ A

Status Flag Output ST

Low output voltage	V_{STL}	–	0.3	0.6	V	$I_{ST} = 1.6$ mA
Leakage current	I_{STLK}	–	0.4	2	μ A	$V_{ST} = 5$ V
Zener-limit-voltage	V_{STZ}	5.4	6.1	–	V	$I_{ST} = 1.6$ mA

Thermal Shutdown

Thermal shutdown junction temperature	T_{jSD}	160	–	190	°C	–
Thermal switch-on junction temperature	T_{jSO}	150	–	180	°C	–
Temperature hysteresis	ΔT	–	10	–	°C	$\Delta T = T_{jSD} - T_{jSO}$

Note: Shutdown temperatures are guaranteed by design

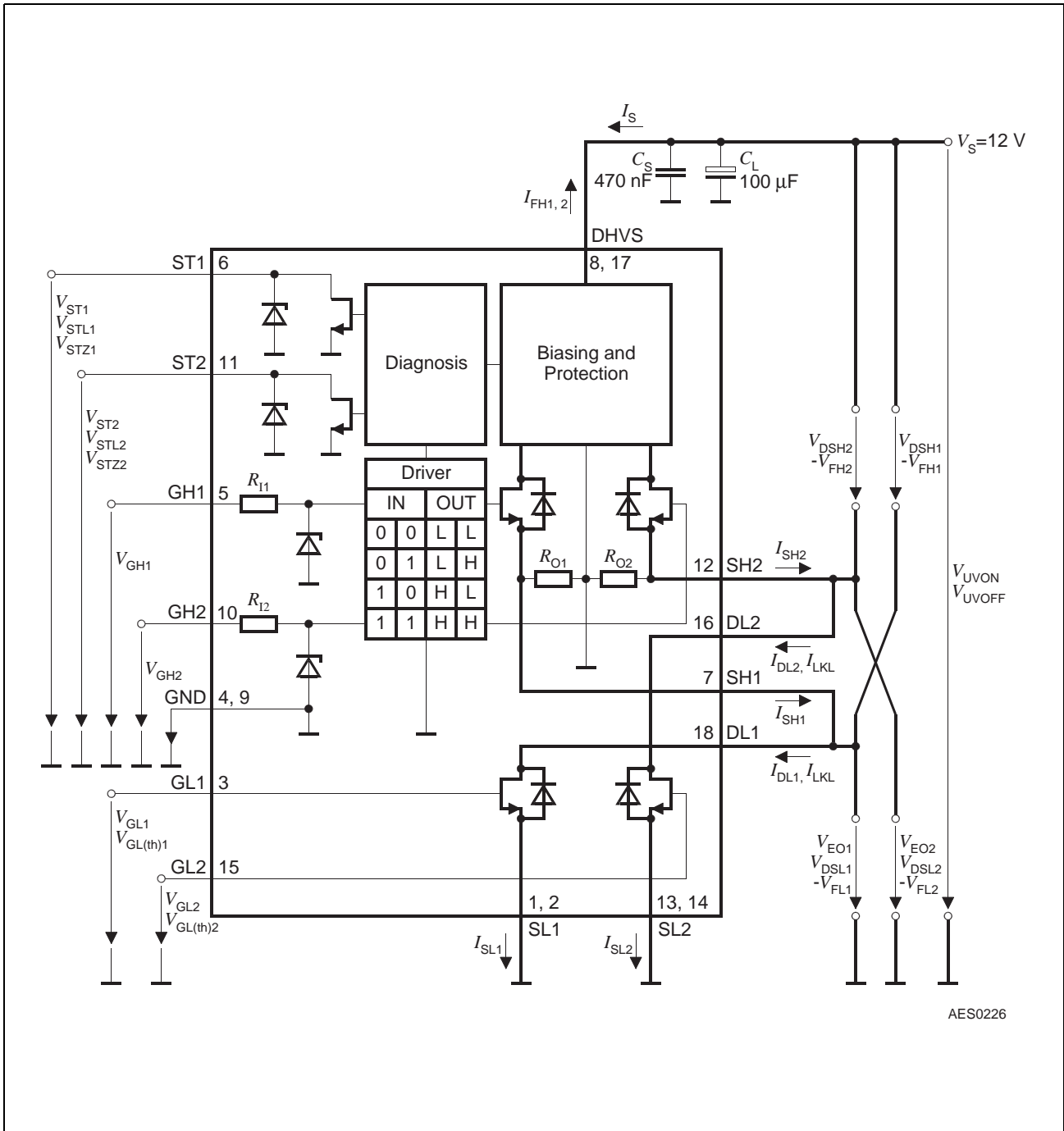

AES0226

Figure 3 Test Circuit

HS-Source-Current	Named during Short Circuit	Named during Open Circuit	Named during Leakage-Cond.
$I_{SH1,2}$	I_{SCP}	I_{OCD}	I_{HSLK}

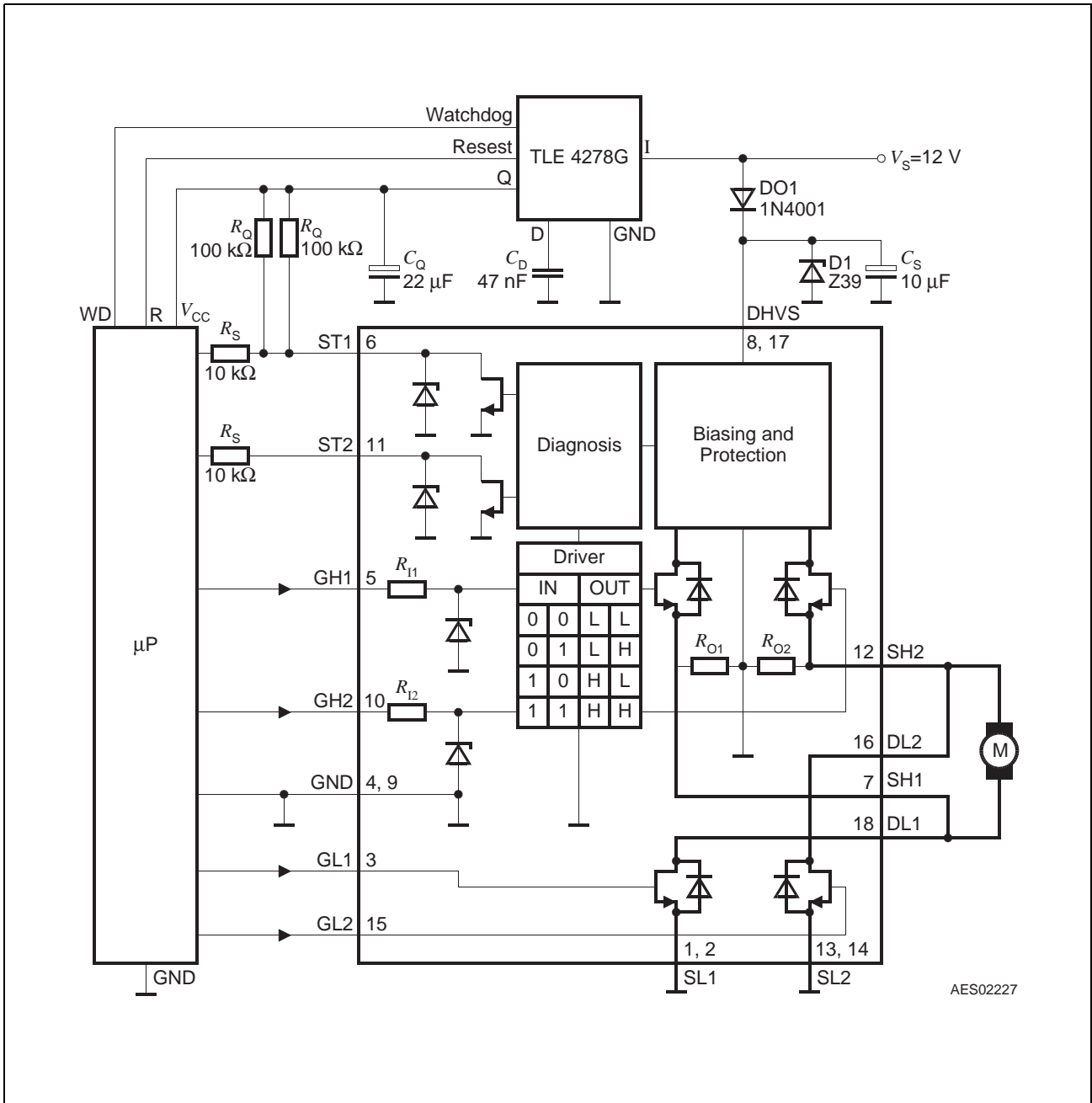

Figure 4 Application Circuit

5 Test-PCB

The Printed Circuit Board is made of 1.5 mm thick standard FR4 material with double sided copper plating of 35 μm thickness. The 28 mm \times 21 mm cooling area is through-connected by a 1.1 mm \times 1.1 mm pattern of vias with 0.5 mm diameter.

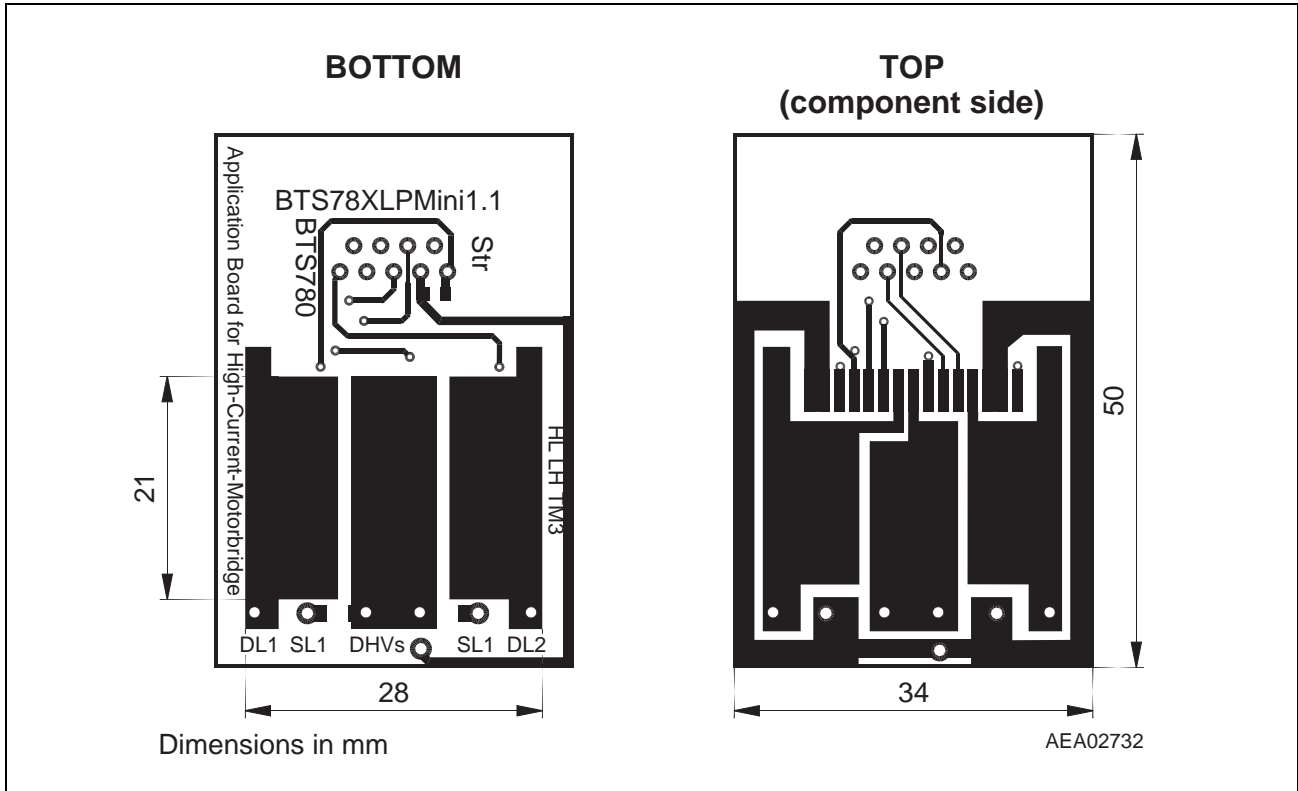
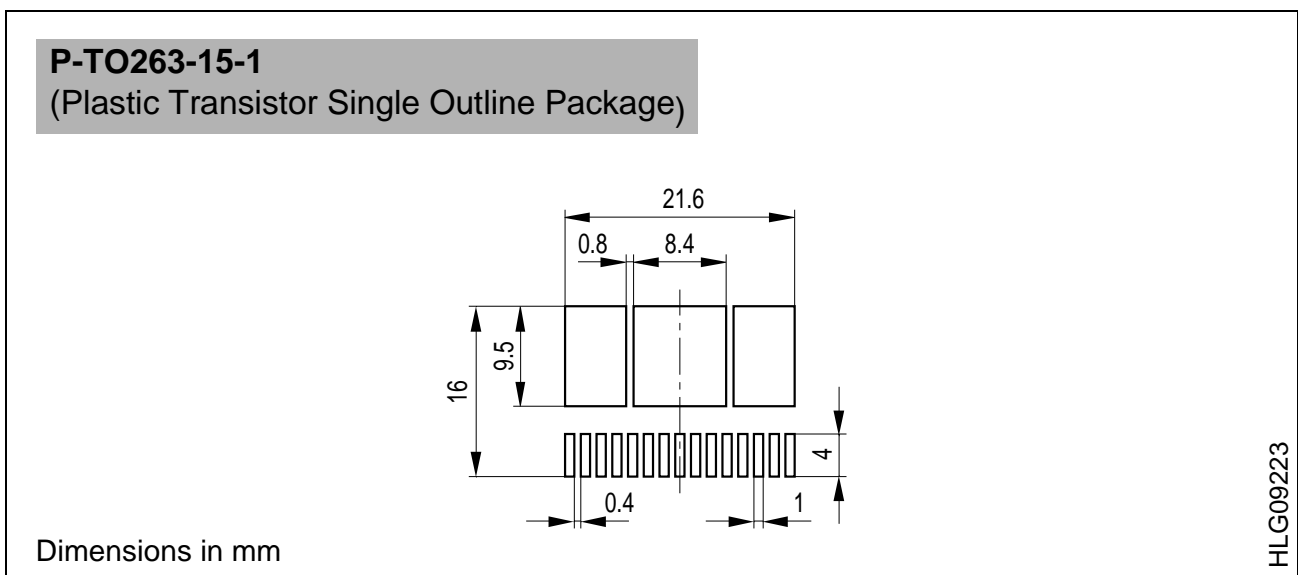

Figure 5 Test-PCB Outline

6 Solder Pad for Reflow Soldering



7 Package Outlines

P-TO263-15-1 (Plastic Transistor Single Outline Package)

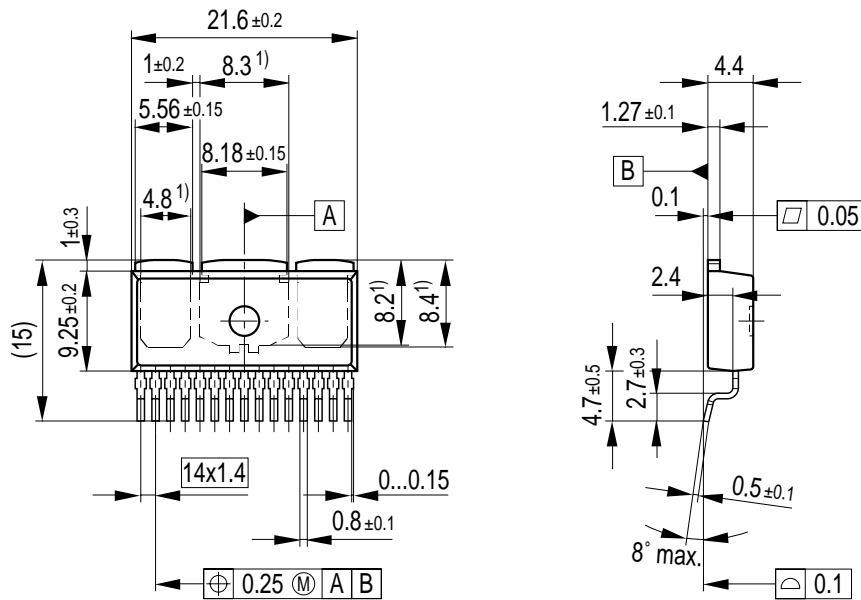

1) Typical
All metal surfaces tin plated, except area of cut.

GPT09151

Sorts of Packing

Package outlines for tubes, trays etc. are contained in our Data Book "Package Information".

SMD = Surface Mounted Device

Dimensions in mm