

ELECTRICAL CHARACTERISTICS ($T_A = 25^\circ\text{C}$ Unless otherwise noted)

PARAMETER		MIN	TYP	MAX	UNITS	TEST CONDITION
Input	Forward Voltage (V_F)		1.2	1.65	V	$I_F = 60\text{mA}$
	Reverse Current (I_R)			10	μA	$V_R = 6\text{V}$
Output	Collector-emitter Breakdown (BV_{CEO}) SFH600-0, 1, 2, 3, 4	70			V	$I_C = 1\text{mA}$ (Note 2)
	SFH601-1, 2, 3, 4, 5	100			V	
	SFH609-1, 2, 3, 4, 5	90			V	
	Collector-base Breakdown (BV_{CBO}) SFH600-0, 1, 2, 3, 4	70			V	$I_C = 100\mu\text{A}$
	SFH601-1, 2, 3, 4, 5	100			V	
	SFH609-1, 2, 3, 4, 5	90			V	
	Emitter-collector Breakdown (BV_{ECO})	6			V	$I_E = 100\mu\text{A}$
	Collector-emitter Dark Current (I_{CEO})			50	nA	$V_{CE} = 10\text{V}$
Coupled	Current Transfer Ratio (CTR) (Note 2) SFH600-0, SFH601-1, SFH609-1	40		80	%	$10\text{mA } I_F, 5\text{V } V_{CE}$
	SFH600-1, SFH601-2, SFH609-2	63		125	%	$10\text{mA } I_F, 5\text{V } V_{CE}$
	SFH600-2, SFH601-3, SFH609-3	100		200	%	$10\text{mA } I_F, 5\text{V } V_{CE}$
	SFH600-3, SFH601-4, SFH609-4	160		320	%	$10\text{mA } I_F, 5\text{V } V_{CE}$
	SFH600-4, SFH601-5, SFH609-5	200		400	%	$10\text{mA } I_F, 5\text{V } V_{CE}$
	SFH600-0, SFH601-1, SFH609-1	13			%	$1\text{mA } I_F, 5\text{V } V_{CE}$
	SFH600-1, SFH601-2, SFH609-2	22			%	$1\text{mA } I_F, 5\text{V } V_{CE}$
	SFH600-2, SFH601-3, SFH609-3	34			%	$1\text{mA } I_F, 5\text{V } V_{CE}$
	SFH600-3, SFH601-4, SFH609-4	56			%	$1\text{mA } I_F, 5\text{V } V_{CE}$
	SFH600-4, SFH601-5, SFH609-5	68			%	$1\text{mA } I_F, 5\text{V } V_{CE}$
	Collector-emitter Saturation Voltage $V_{CE(SAT)}$			0.4	V	$10\text{mA } I_F, 2.5\text{mA}$
	Input to Output Isolation Voltage V_{ISO}	5300			V_{RMS}	See note 1
		7500			V_{PK}	See note 1
Input-output Isolation Resistance R_{ISO}	5×10^{10}			Ω	$V_{IO} = 500\text{V}$ (note 1)	

Note 1 Measured with input leads shorted together and output leads shorted together.

Note 2 Special Selections are available on request. Please consult the factory.

TYPICAL SWITCHING CHARACTERISTICS

1. Linear Operation (without saturation) Fig 1.

$I_F = 10\text{mA}, V_{CC} = 5\text{V}, R_L = 75\Omega$

		UNITS
Turn-on Time t_{on}	3.0	μs
Rise Time t_r	2.0	μs
Turn-off Time t_{off}	2.3	μs
Fall Time t_f	2.0	μs
Cut-off Frequency F_{CO}	250	kHz

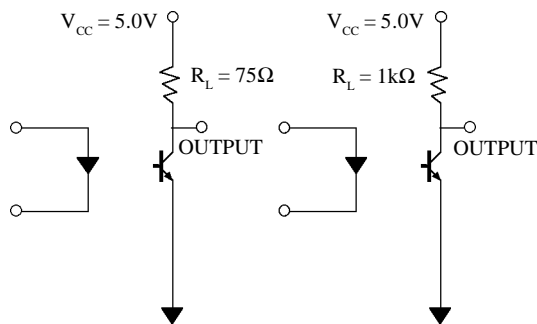

FIG 1

FIG 2

2. Switching Operation (with saturation) Fig 2

$V_{CC} = 5\text{V}, R_L = 1\text{k}\Omega$

GROUP	600-0 601/9-1 ($I_F = 20\text{mA}$)	600-1&2 601/9-2&3 ($I_F = 10\text{mA}$)	600-3 601/9-4&5 ($I_F = 5\text{mA}$)	UNITS
Turn-on Time t_{on}	3.0	4.2	6.0	μs
Rise Time t_r	2.0	3.0	4.6	μs
Turn-off Time t_{off}	18	23	25	μs
Fall Time t_f	11	14	15	μs
V_{CESAT}	≤ 0.4			V

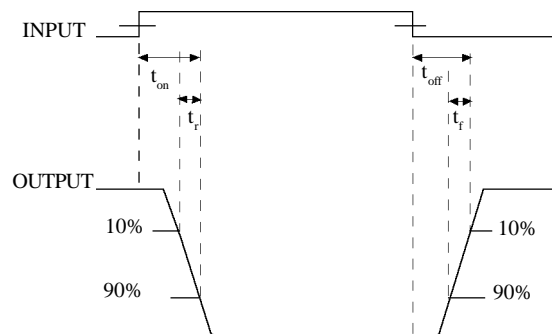

Collector Power Dissipation vs. Ambient Temperature

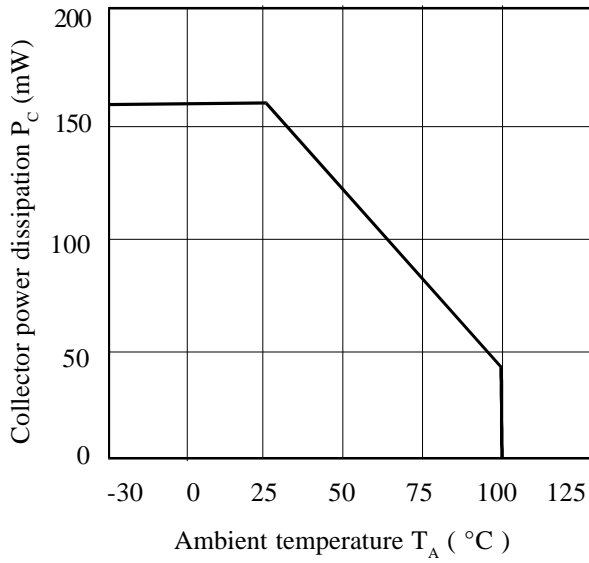

Collector Current vs. Collector-emitter Voltage (normalised to SFH601-3)

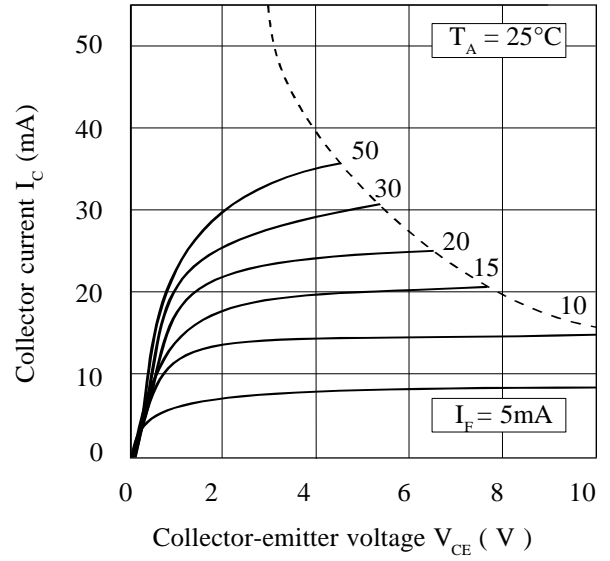

Forward Current vs. Ambient Temperature

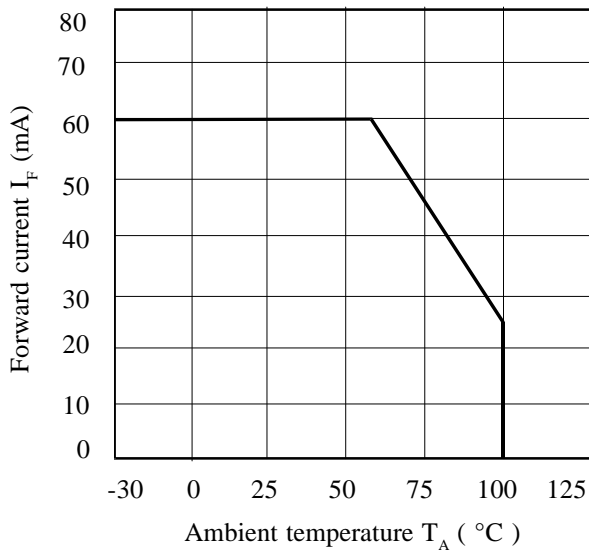

Current Transfer Ratio vs. Forward Current

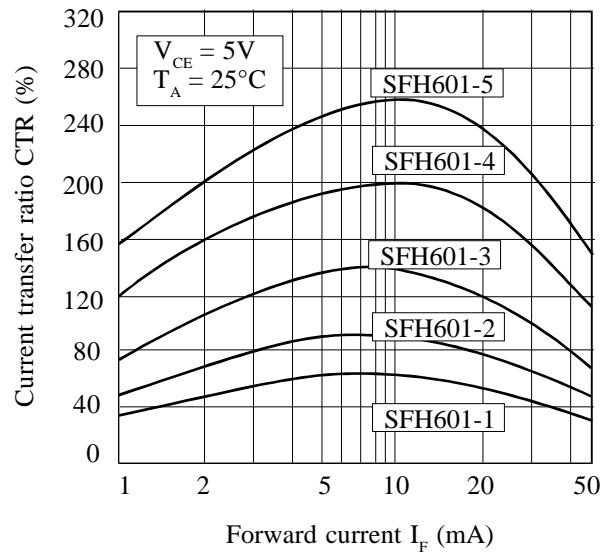

Relative Current Transfer Ratio vs. Ambient Temperature

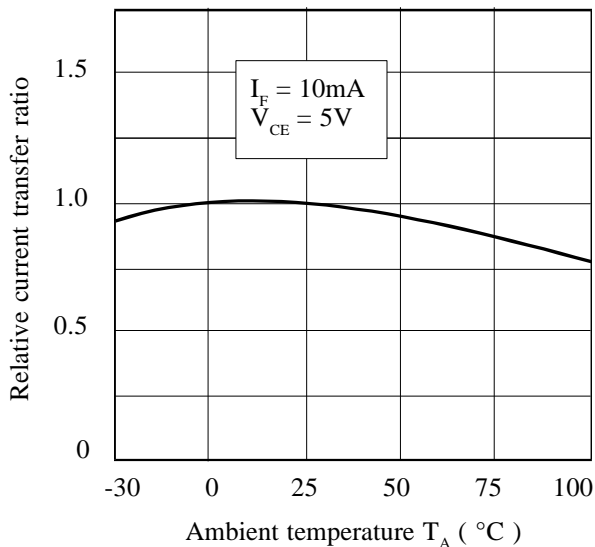

Collector-emitter Saturation Voltage vs. Ambient Temperature

