

# 2559

## PROTECTED QUAD POWER DRIVER

UDx2559B

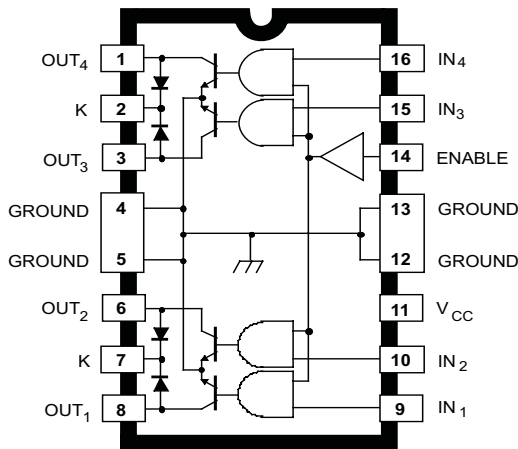

Dwg. PP-017-1

### ABSOLUTE MAXIMUM RATINGS

at  $T_A = 25^\circ\text{C}$

|   |                        |
|---|------------------------|
| Output Voltage, $V_{OUT}$ . . . . .                           | <b>60 V</b>            |
| Over-Current Protected Output Voltage,<br>$V_{OUT}$ . . . . . | <b>25 V</b>            |
| Output Current, $I_{OUT}$ . . . . .                           | <b>1.0 A*</b>          |
| Supply Voltage, $V_{CC}$ . . . . .                            | <b>7.0 V</b>           |
| Input Voltage, $V_{IN}$ or $V_{EN}$ . . . . .                 | <b>7.0 V</b>           |
| Package Power Dissipation,<br>$P_D$ . . . . .                 | <b>See Graph</b>       |
| Operating Temperature Range, $T_A$                            |                        |
| Prefix 'UDK' . . . . .  | <b>-40°C to +125°C</b> |
| Prefix 'UDN' . . . . .  | <b>-20°C to +85°C</b>  |
| Prefix 'UDQ' . . . . .  | <b>-40°C to +85°C</b>  |
| Storage Temperature Range,<br>$T_S$ . . . . .                 | <b>-55°C to +150°C</b> |

\*Outputs are peak current limited at approximately 1.0 A per driver. See Circuit Description and Application for further information.

Providing improved output current limiting, the UDK, UDN, and UDQ2559B, EB, and LB quad power drivers combine AND logic gates and high-current bipolar outputs with complete output protection. Each of the four outputs will sink 700 mA in the on state. The outputs have a minimum breakdown voltage (load dump) of 60 V and a sustaining voltage of 40 V. The inputs are compatible with TTL and 5 V CMOS logic systems.

Over-current protection for each channel has been designed into these devices and is activated at approximately 1 A. It protects each output from short circuits with supply voltages up to 25 V. When an output current trip point is reached, that output stage is driven linearly resulting in a reduced output current level. If an over-current or short-circuit condition continues, the thermal-limiting circuits will first sense the rise in junction temperature and then the rise in chip temperature, further decreasing the output current. Under worst-case conditions, these devices will tolerate short circuits on all outputs, simultaneously.

These devices can be used to drive various loads including incandescent lamps (without warming or limiting resistors) or inductive loads such as relays, solenoids, or dc stepping motors.

The packages offer fused leads for enhanced thermal dissipation. Package B is a 16-pin power DIP with exposed tabs, EB is a 28-lead power PLCC, and LB is a 16-lead power wide-body SOIC for surface-mount applications. The lead (Pb) free versions have 100% matte tin leadframe plating.

### FEATURES

- 700 mA Output Current per Channel
- Independent Over-Current Protection for Each Driver
- Thermal Protection for Device and Each Driver
- Low Output-Saturation Voltage
- Integral Output Flyback Diodes
- TTL and 5 V CMOS Compatible Inputs

# 2559 PROTECTED QUAD POWER DRIVER

## Selection Guide

| Part Number | Pb-free | Package                  | Ambient Temperature (°C) |
|-------------|---------|--------------------------|--------------------------|
| UDN2559B    | –       | 16-pin DIP, exposed tabs | –20 to 85                |
| UDN2559B-T  | Yes     | 16-pin DIP, exposed tabs |                          |
| UDN2559EB   | –       | 28-lead PLCC             |                          |
| UDN2559EB-T | Yes     | 28-lead PLCC             |                          |
| UDN2559LB   | Yes     | 16-lead SOIC             |                          |
| UDN2559LB-T | Yes     | 16-lead SOIC             |                          |
| UDQ2559B    | –       | 16-pin DIP, exposed tabs | –40 to 85                |
| UDQ2559B-T  | Yes     | 16-pin DIP, exposed tabs |                          |
| UDQ2559LB   | –       | 16-lead SOIC             |                          |
| UDQ2559LB-T | Yes     | 16-lead SOIC             |                          |
| UDK2559B    | –       | 16-pin DIP, exposed tabs | –40 to 125               |
| UDK2559B-T  | Yes     | 16-pin DIP, exposed tabs |                          |
| UDK2559EB   | –       | 28-lead PLCC             |                          |
| UDK2559EB-T | Yes     | 28-lead PLCC             |                          |
| UDK2559LB   | –       | 16-lead SOIC             |                          |
| UDK2559LB-T | Yes     | 16-pin DIP, exposed tabs |                          |

## UDx2559LB

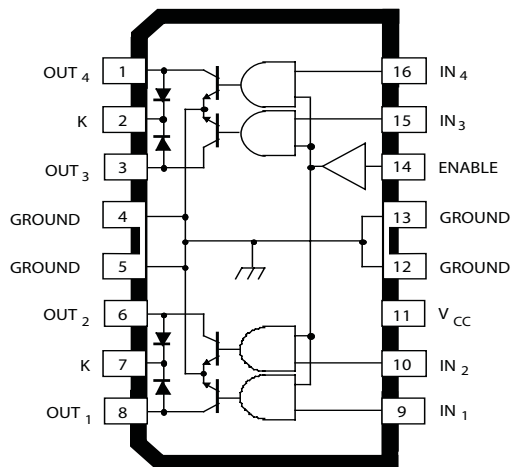

Dwg. PP-017-6

# 2559 PROTECTED QUAD POWER DRIVER

## FUNCTIONAL BLOCK DIAGRAM

(1 of 4 Channels)

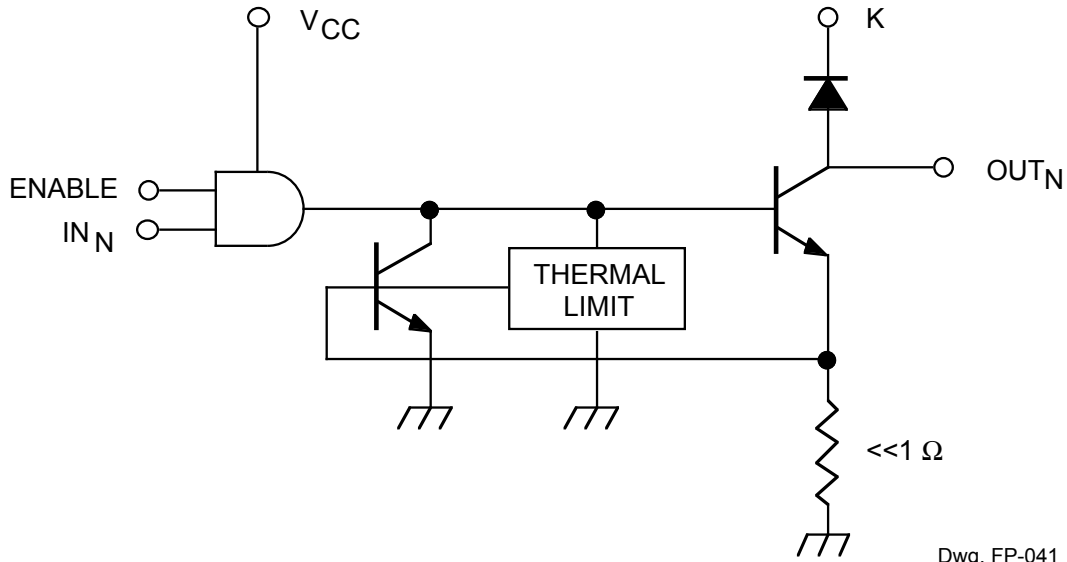

Dwg. FP-041

## UDx2559EB

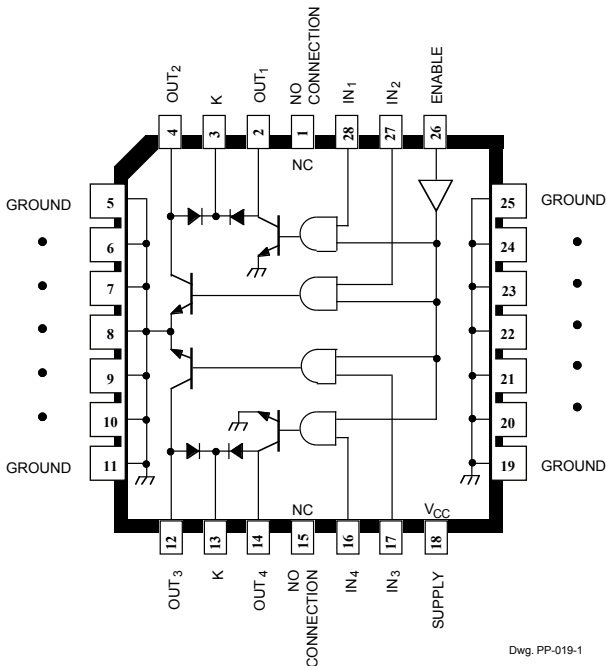

Dwg. PP-019-1

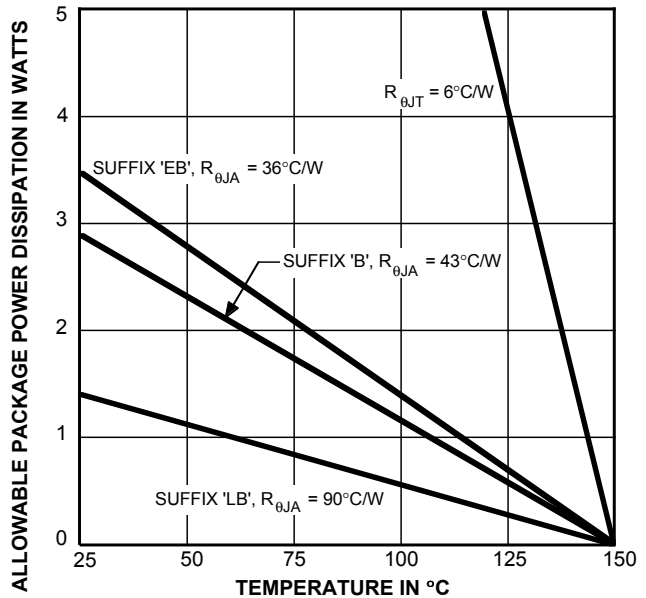

Dwg. GP-004-2B

$$P_D = (V_{OUT1} \times I_{OUT1} \times dc) + \dots + (V_{OUTn} \times I_{OUTn} \times dc) + (V_{CC} \times I_{CC}) = (T_J - T_A) / R_{\theta JA}$$



**2559**  
**PROTECTED**  
**QUAD POWER DRIVER**

**ELECTRICAL CHARACTERISTICS at  $T_A = +25^\circ\text{C}$  (prefix 'UDN') or over operating temperature range (prefix 'UDK' or 'UDQ'),  $V_{CC} = 4.75\text{ V}$  to  $5.25\text{ V}$**

| Characteristic              | Symbol         | Test Conditions   | Limits |      |      |                  |
|-----------------------------|----------------|---|--------|------|------|------------------|
|                             |                |   | Min.   | Typ. | Max. | Units            |
| Output Leakage Current      | $I_{CEX}$      | $V_{OUT} = 50\text{ V}$ , $V_{IN} = 0.8\text{ V}$ , $V_{EN} = 2.0\text{ V}$ | —      | <1.0 | 100  | $\mu\text{A}$    |
|                             |                | $V_{OUT} = 50\text{ V}$ , $V_{IN} = 2.0\text{ V}$ , $V_{EN} = 0.8\text{ V}$ | —      | <1.0 | 100  | $\mu\text{A}$    |
| Output Sustaining Voltage   | $V_{OUT(SUS)}$ | $I_{OUT} = 100\text{ mA}$ , $V_{IN} = V_{EN} = 0.8\text{ V}$                | 40     | —    | —    | V                |
| Output Saturation Voltage   | $V_{OUT(SAT)}$ | All Devices, $I_{OUT} = 100\text{ mA}$                                      | —      | —    | 300  | mV               |
|                             |                | All Devices, $I_{OUT} = 400\text{ mA}$                                      | —      | —    | 500  | mV               |
|                             |                | 'B' & 'EB' Packages Only, $I_{OUT} = 600\text{ mA}$                         | —      | —    | 700  | mV               |
| Over-Current Trip           | $I_{TRIP}$     |   | —      | 1.0  | —    | A                |
| Input Voltage               | Logic 1        | $V_{IN(1)}$ or $V_{EN(1)}$  | 2.0    | —    | —    | V                |
|                             | Logic 0        | $V_{IN(0)}$ or $V_{EN(0)}$  | —      | —    | 0.8  | V                |
| Input Current               | Logic 1        | $V_{IN(1)}$ or $V_{EN(1)} = 2.0\text{ V}$                                   | —      | —    | 40   | $\mu\text{A}$    |
|                             | Logic 0        | $V_{IN(0)}$ or $V_{EN(0)} = 0.8\text{ V}$                                   | —      | —    | -10  | $\mu\text{A}$    |
| Total Supply Current        | $I_{CC}$       | All Outputs ON, $V_{IN}^* = V_{EN} = 2.0\text{ V}$                          | —      | —    | 80   | mA               |
|                             |                | All Outputs OFF   | —      | —    | 5.0  | mA               |
| Clamp Diode Forward Voltage | $V_F$          | $I_F = 1.0\text{ A}$  | —      | —    | 1.7  | V                |
|                             |                | $I_F = 1.5\text{ A}$  | —      | —    | 2.1  | V                |
| Clamp Diode Leakage Current | $I_R$          | $V_R = 50\text{ V}$ , $D_1 + D_2$ or $D_3 + D_4$                            | —      | —    | 50   | $\mu\text{A}$    |
| Turn-On Delay               | $t_{PHL}$      | $I_{OUT} = 500\text{ mA}$   | —      | —    | 20   | $\mu\text{s}$    |
|                             | $t_{PLH}$      | $I_{OUT} = 500\text{ mA}$   | —      | —    | 20   | $\mu\text{s}$    |
| Thermal Limit               | $T_J$          |   | —      | 165  | —    | $^\circ\text{C}$ |

Typical Data is for design information only.

Negative current is defined as coming out of (sourcing) the specified terminal.

As used here, -100 is defined as greater than +10 (absolute magnitude convention) and the minimum is implicitly zero.

\* All inputs simultaneously, all other tests are performed with each input tested separately.

# 2559 PROTECTED QUAD POWER DRIVER

## TYPICAL OUTPUT CHARACTERISTIC

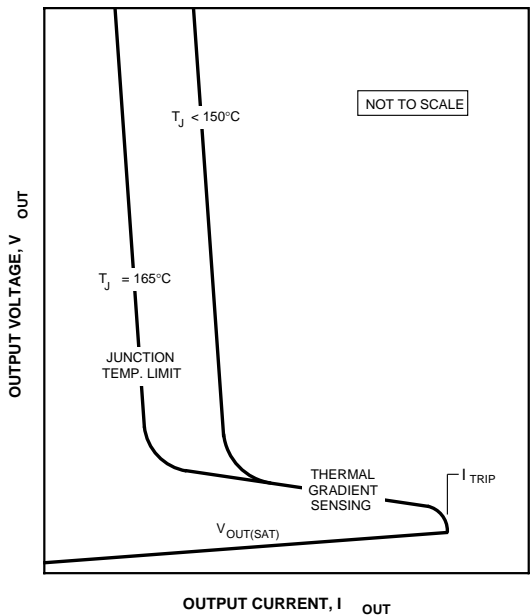

Dwg. GP-013

## TYPICAL OUTPUT BEHAVIOR

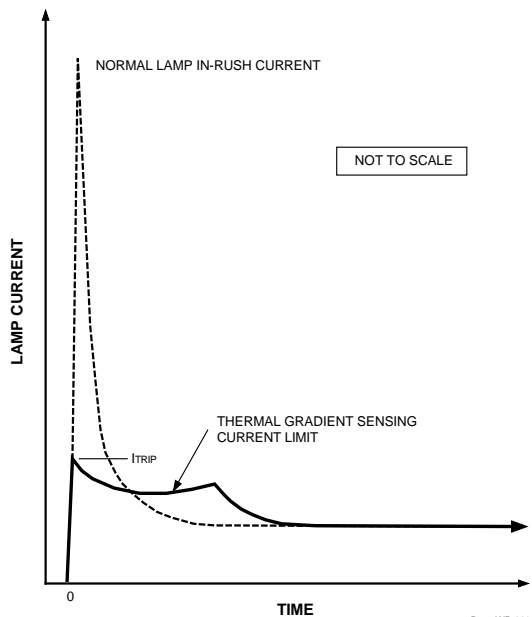

Dwg. WP-008

## CIRCUIT DESCRIPTION AND APPLICATION

### INCANDESCENT LAMP DRIVER

High incandescent lamp turn-ON/in-rush currents can contribute to poor lamp reliability and destroy semiconductor lamp drivers. Warming or current-limiting resistors protect both driver and lamp but use significant power either when the lamp is OFF or when the lamp is ON, respectively. Lamps with steady-state current ratings up to 700 mA can be driven by these devices without the need for warming (parallel) or current-limiting (series) resistors.

When an incandescent lamp is initially turned ON, the cold filament is at minimum resistance and would normally allow a 10x to 12x in-rush current. With these drivers, during turn-ON, the high in-rush current is sensed by the internal low-value sense resistor. Drive current to the output stage is then diverted by the shunting transistor, and the load current is momentarily limited to approximately 1.0 A. During this short transition period, the output current is reduced to a value dependent on supply voltage and filament resistance. During lamp warmup, the filament resistance increases to its maximum value, the output stage goes into saturation and applies maximum rated voltage to the lamp.

### INDUCTIVE LOAD DRIVER

Bifilar (unipolar) stepper motors, relays, or solenoids can be driven directly. The internal flyback diodes prevent damage to the output transistors by suppressing the high-voltage spikes that occur when turning OFF an inductive load.

For rapid current decay (fast turn-OFF speeds), the use of Zener diodes will raise the flyback voltage and improve performance. However, the peak voltage must not exceed the specified minimum sustaining voltage ( $V_{SUPPLY} + V_Z + V_F \leq V_{OUT(SUS)}$ ).

### FAULT CONDITIONS

In the event of a shorted load, the load current will attempt to increase. As described above, the drive current to the affected output stage is reduced, causing the output stage to go linear, limiting the peak output current to approximately 1 A. As the power dissipation of that output stage increases, a thermal gradient sensing circuit will become operational, further decreasing the drive current to the affected output stage and reducing the output current to a value dependent on supply voltage and load resistance.

Continuous or multiple overload conditions causing the chip temperature to reach approximately  $165^\circ\text{C}$  will result in an additional reduction in output current to maintain a safe level.

If the fault condition is corrected, the output stage will return to its normal saturated condition.

# 2559 PROTECTED QUAD POWER DRIVER

## B Package, 16-pin DIP with internally fused pins 4, 5, 12, and 13 and external thermal tabs

Preliminary dimensions, for reference only  
 Dimensions in inches  
 Metric dimensions (mm) in brackets, for reference only  
 (reference JEDEC MS-001 BB)  
 Dimensions exclusive of mold flash, gate burrs, and dambar protrusions  
 Exact case and lead configuration at supplier discretion within limits shown

 Terminal #1 mark area

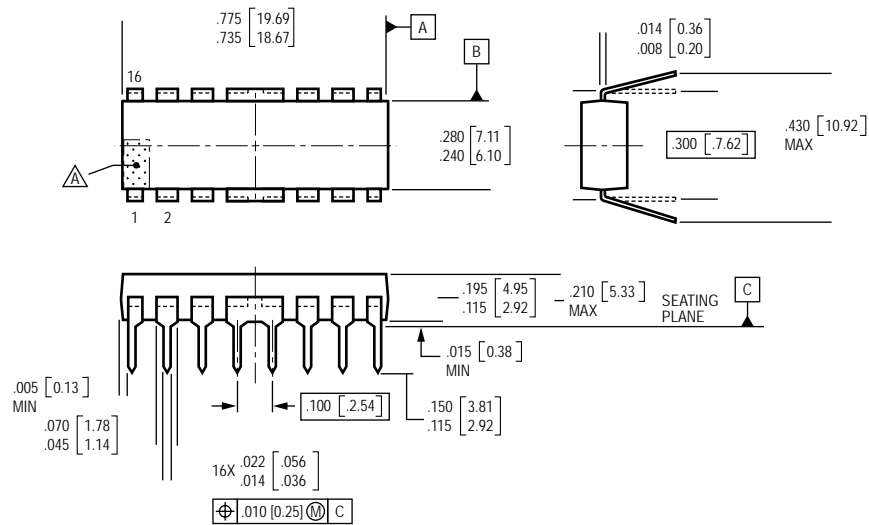

# 2559 PROTECTED QUAD POWER DRIVER

## EB Package, 28-pin PLCC with internally fused pins 5 through 11 and 19 through 25

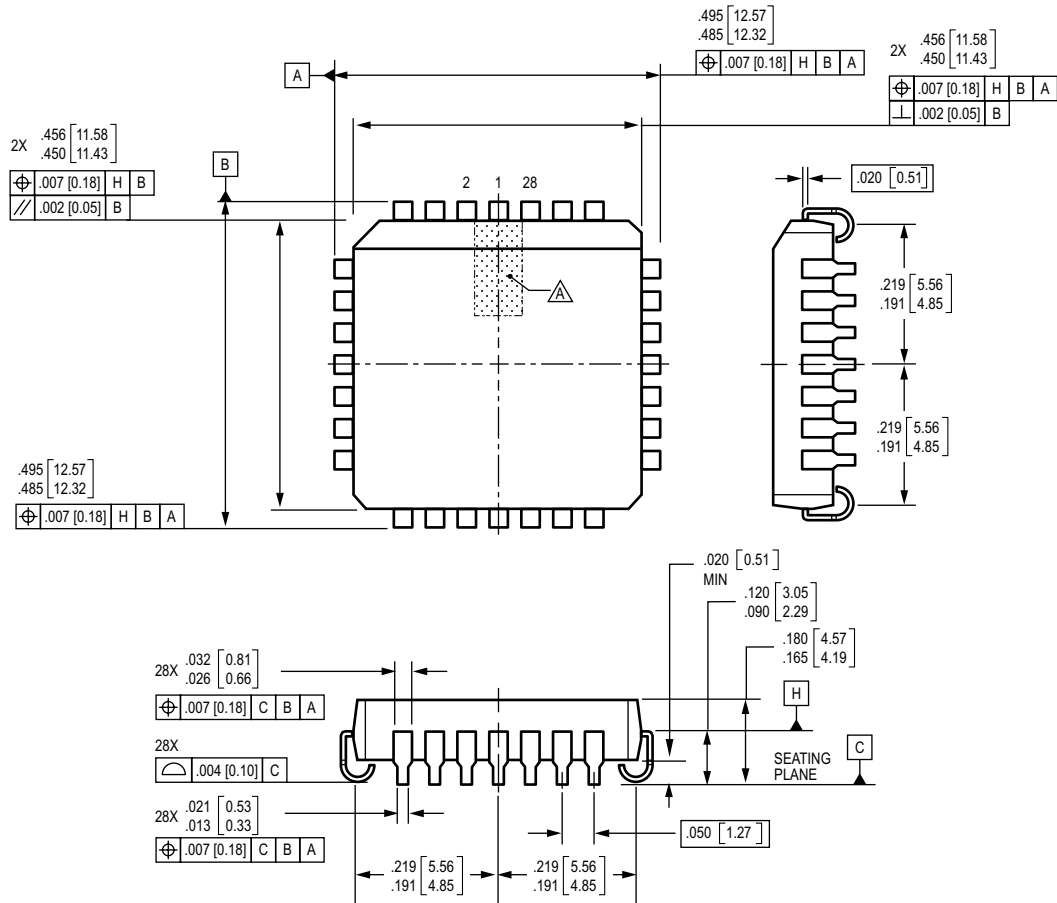

Preliminary dimensions, for reference only  
(reference JEDEC MS-018 AB)  
Dimensions in inches  
Millimeters (mm) in brackets, for reference only  
Dimensions exclusive of mold flash, gate burrs, and dambar protrusions  
Exact case and lead configuration at supplier discretion within limits shown  
△ Terminal #1 mark area



**2559**  
**PROTECTED**  
**QUAD POWER DRIVER**

*The products described here are manufactured under one or more U.S. patents or U.S. patents pending.*

*Allegro MicroSystems, Inc. reserves the right to make, from time to time, such departures from the detail specifications as may be required to permit improvements in the performance, reliability, or manufacturability of its products. Before placing an order, the user is cautioned to verify that the information being relied upon is current.*

*Allegro products are not authorized for use as critical components in life-support devices or systems without express written approval.*

*The information included herein is believed to be accurate and reliable. However, Allegro MicroSystems, Inc. assumes no responsibility for its use; nor for any infringement of patents or other rights of third parties which may result from its use.*

