

QUICK START GUIDE FOR DEMONSTRATION CIRCUIT DC1084A-A HIGH DENSITY POWER MODULE

LTM4602EV

DESCRIPTION

Demonstration circuit DC1084A-A features the LTM[®]4602EV, the high efficiency, high density switch mode step-down power module. The input voltage range is from 5V to 20V. The output voltage is programmable from 0.6V to 5V, refer to step down ratio curve in the LTM4602 datasheet. The rated load current is 5A, while de-rating is necessary for certain V_{IN} , V_{OUT} , and thermal

conditions. Integrated input and output filters enable a simple PCB layout. Only bulk input and output capacitors are needed.

Design files for this circuit board are available. Call the LTC Factory.

 , LTC and LT are registered trademarks of Linear Technology Corporation.

Table 1. Performance Summary ($T_A = 25^\circ\text{C}$)

PARAMETER	CONDITION	VALUE
Minimum Input Voltage		4.5V
Maximum Input Voltage		20V
Output Voltage V_{OUT}	Jumper selectable (open for 0.6V)	1.2V, 1.5V, 1.8V, 2.5V, 3.3V, 5V
Maximum Continuous Output Current	De-rating is necessary for certain V_{IN} , V_{OUT} , and thermal conditions	$5A_{DC}$
Default Operating Frequency		800kHz
Efficiency	$V_{IN}=12V$, $V_{OUT}=1.5V$, $I_{OUT}=5A$	85%, See Figure 2
Load Transient	$V_{IN}=12V$, $V_{OUT}=1.5V$	See Figure 3 and Table 1 for details

QUICK START PROCEDURE

Demonstration circuit DC1084A-A is easy to set up to evaluate the performance of the LTM4602EV. Please refer to Figure 1 for proper measurement equipment setup and follow the procedure below:

1. Place jumpers in the following positions for a typical $1.5V_{OUT}$ application:

Vout Select	FCB	RUN
1.5V	CCM	ON

2. With power off, connect the input power supply, load, optional 5V bias supply and meters as shown in Figure 1. Preset the load to 0A and V_{in} supply to be less than 20V. The optional 5V bias supply must be off while the main V_{in} is turned off

3. Turn on the power at the input. The output voltage should be $1.5V \pm 2\%$.
4. Once the proper output voltage is established, adjust the load within the operating range and observe the output voltage regulation, ripple voltage, efficiency and other parameters. Output ripple should be measured at J6 with a BNC cable.
5. For optional load transient test, apply adjustable pulse signal between IOSTEP CLK and GND pins. Pulse amplitude sets the current step. The pulse signal should have very small duty cycle (<15%) to limit the thermal stress on the transient load circuit. The output transient current can be monitored at BNC connector J5 (10mV/A).

QUICK START GUIDE FOR DEMONSTRATION CIRCUIT DC1084A-A HIGH DENSITY POWER MODULE

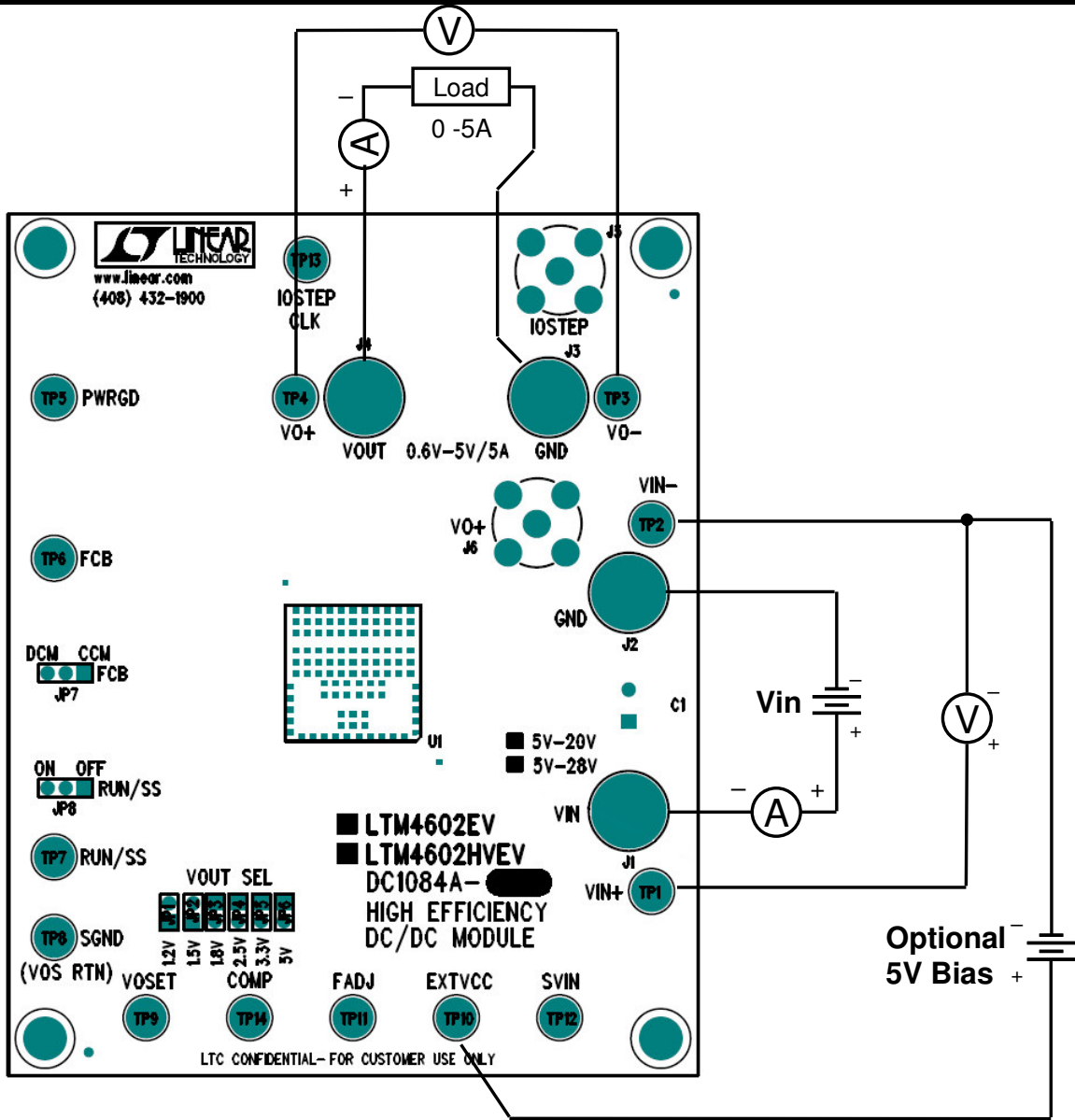

Figure 1. Test Setup of DC1084A-A (EXTVCC Bias Supply is Optional)

QUICK START GUIDE FOR DEMONSTRATION CIRCUIT DC1084A-A HIGH DENSITY POWER MODULE

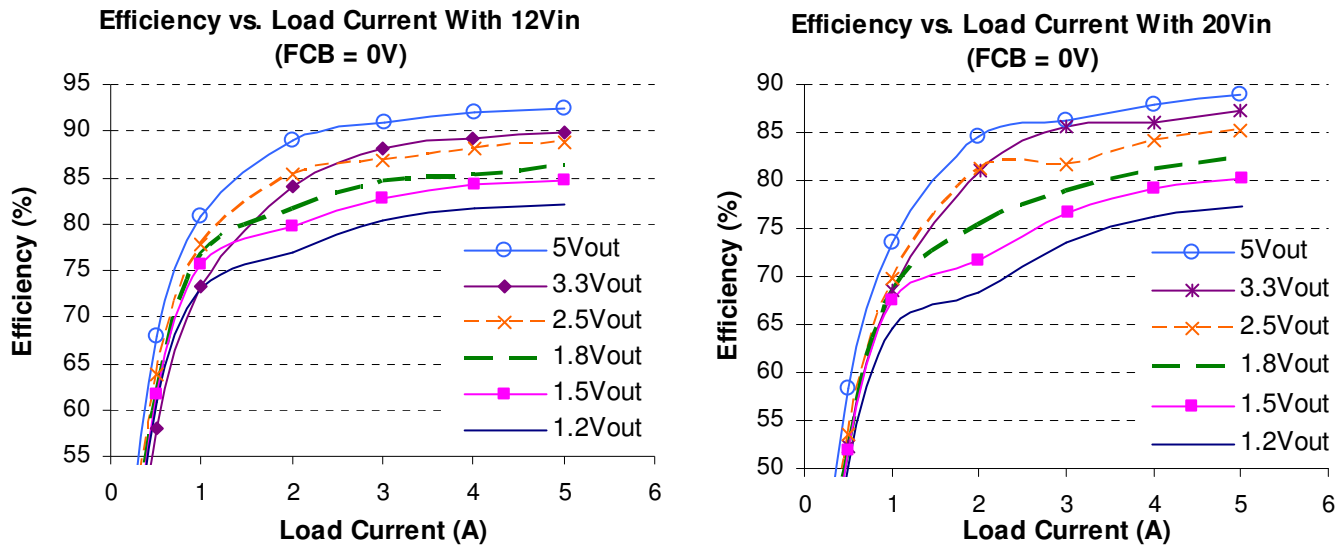
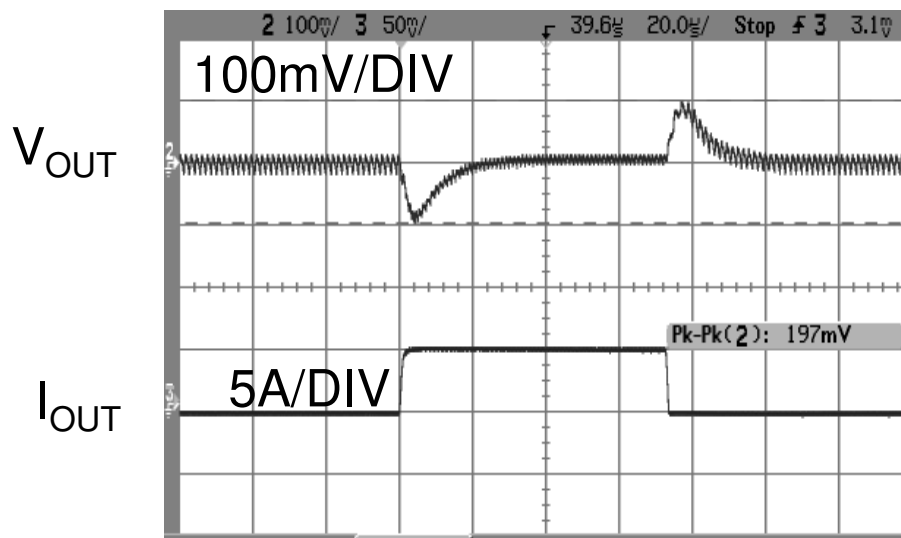

Figure 2. Measured Supply Efficiency with Different V_{IN} and V_{OUT} (Fadj open: 1.2Vo-2.5Vo, Fadj = 15kohm: 3.3Vo-5Vo)



$V_{in} = 12V$
 $V_{out} = 1.5V$
 0A to 5A LOAD STEP
 $FCB = 0V$
 $C_{out} = 1 \times 22\mu F$ ceramic(1206), $1 \times 100\mu F$ ceramic(1812), $C3 = 100pF$

Figure 3. Measured Load Transient Response (0-5A Step)

QUICK START GUIDE FOR DEMONSTRATION CIRCUIT DC1084A-A HIGH DENSITY POWER MODULE

Table1. Output Capacitor vs, Load Transient (0-5A Step)

TYPICAL MEASURED VALUES			
C _{OUT1} VENDORS	PART NUMBER	C _{OUT2} VENDORS	PART NUMBER
TDK	C4532X5R0J107MZ (100UF, 6.3V)	SANYO POS CAP	6TPE330ML (330UF, 6.3V)
TAIYO YUDEN	JMK432BJ107MU-T (100UF, 6.3V)	SANYO POS CAP	2R5TPE470M9 (470UF, 2.5V)
TAIYO YUDEN	JMK316BJ226ML-T501 (22UF, 6.3V)	SANYO POS CAP	4TPE470MCL (470UF, 4V)

LTM4602 module has similar load transient response at 12Vin and 24Vin

V _{OUT} (V)	C _{IN} (Ceramic)	C _{IN} (BULK)	C _{OUT1} (CERAMIC)	C _{OUT2} (BULK)	C _{COMP}	C ₃	V _{IN} (V)	DROOP (mV)	PEAK TO PEAK (mV)	RECOVERY TIME (μs)	LOAD STEP (A/μs)
1.2	2x 10uF 25V	150uF 35V	3 x 22uF 6.3V	470uF 4V	NONE	100pF	5	50	60	25	3
1.2	2x 10uF 25V	150uF 35V	1 x 100uF 6.3V	470uF 2.5V	NONE	100pF	5	30	60	20	3
1.2	2x 10uF 25V	150uF 35V	2 x 100uF 6.3V	330uF 6.3V	NONE	100pF	5	25	54	20	3
1.2	2x 10uF 25V	150uF 35V	4 x 100uF 6.3V	NONE	NONE	100pF	5	25	55	20	3
1.2	2x 10uF 25V	150uF 35V	3 x 22uF 6.3V	470uF 4V	NONE	100pF	12	30	60	25	3
1.2	2x 10uF 25V	150uF 35V	1 x 100uF 6.3V	470uF 2.5V	NONE	100pF	12	25	54	20	3
1.2	2x 10uF 25V	150uF 35V	2 x 100uF 6.3V	330uF 6.3V	NONE	100pF	12	25	50	20	3
1.2	2x 10uF 25V	150uF 35V	4 x 100uF 6.3V	NONE	NONE	100pF	12	25	55	20	3
1.5	2x 10uF 25V	150uF 35V	3 x 22uF 6.3V	470uF 4V	NONE	100pF	5	25	50	25	3
1.5	2x 10uF 25V	150uF 35V	1 x 100uF 6.3V	470uF 2.5V	NONE	100pF	5	25	54	20	3
1.5	2x 10uF 25V	150uF 35V	2 x 100uF 6.3V	330uF 6.3V	NONE	100pF	5	28	59	20	3
1.5	2x 10uF 25V	150uF 35V	4 x 100uF 6.3V	NONE	NONE	100pF	5	26	59	20	3
1.5	2x 10uF 25V	150uF 35V	3 x 22uF 6.3V	470uF 4V	NONE	100pF	12	25	55	25	3
1.5	2x 10uF 25V	150uF 35V	1 x 100uF 6.3V	470uF 2.5V	NONE	100pF	12	25	54	20	3
1.5	2x 10uF 25V	150uF 35V	2 x 100uF 6.3V	330uF 6.3V	NONE	100pF	12	28	59	20	3
1.5	2x 10uF 25V	150uF 35V	4 x 100uF 6.3V	NONE	NONE	100pF	12	26	59	20	3
1.8	2x 10uF 25V	150uF 35V	3 x 22uF 6.3V	470uF 4V	NONE	100pF	5	25	54	30	3
1.8	2x 10uF 25V	150uF 35V	1 x 100uF 6.3V	470uF 2.5V	NONE	100pF	5	25	50	20	3
1.8	2x 10uF 25V	150uF 35V	2 x 100uF 6.3V	330uF 6.3V	NONE	100pF	5	25	50	20	3
1.8	2x 10uF 25V	150uF 35V	4 x 100uF 6.3V	NONE	NONE	100pF	5	29	60	20	3
1.8	2x 10uF 25V	150uF 35V	3 x 22uF 6.3V	470uF 4V	NONE	100pF	12	25	50	30	3
1.8	2x 10uF 25V	150uF 35V	1 x 100uF 6.3V	470uF 2.5V	NONE	100pF	12	25	50	20	3
1.8	2x 10uF 25V	150uF 35V	2 x 100uF 6.3V	330uF 6.3V	NONE	100pF	12	25	50	20	3
1.8	2x 10uF 25V	150uF 35V	4 x 100uF 6.3V	NONE	NONE	100pF	12	29	60	20	3
2.5	2x 10uF 25V	150uF 35V	1 x 100uF 6.3V	470uF 4V	NONE	220pF	5	25	50	30	3
2.5	2x 10uF 25V	150uF 35V	2 x 100uF 6.3V	330uF 6.3V	NONE	220pF	5	25	50	30	3
2.5	2x 10uF 25V	150uF 35V	3 x 22uF 6.3V	470uF 4V	NONE	220pF	5	25	50	30	3
2.5	2x 10uF 25V	150uF 35V	4 x 100uF 6.3V	NONE	NONE	220pF	5	25	50	25	3
2.5	2x 10uF 25V	150uF 35V	1 x 100uF 6.3V	470uF 4V	NONE	220pF	12	25	50	30	3
2.5	2x 10uF 25V	150uF 35V	3 x 22uF 6.3V	470uF 4V	NONE	220pF	12	25	50	30	3
2.5	2x 10uF 25V	150uF 35V	2 x 100uF 6.3V	330uF 6.3V	NONE	220pF	12	25	50	30	3
2.5	2x 10uF 25V	150uF 35V	4 x 100uF 6.3V	NONE	NONE	220pF	12	27	54	25	3
3.3	2x 10uF 25V	150uF 35V	2 x 100uF 6.3V	330uF 6.3V	NONE	220pF	7	32	64	30	3
3.3	2x 10uF 25V	150uF 35V	1 x 100uF 6.3V	470uF 4V	NONE	220pF	7	30	60	30	3
3.3	2x 10uF 25V	150uF 35V	3 x 22uF 6.3V	470uF 4V	NONE	220pF	7	30	60	35	3
3.3	2x 10uF 25V	150uF 35V	4 x 100uF 6.3V	NONE	NONE	220pF	7	32	64	25	3
3.3	2x 10uF 25V	150uF 35V	1 x 100uF 6.3V	470uF 4V	NONE	220pF	12	38	58	30	3
3.3	2x 10uF 25V	150uF 35V	3 x 22uF 6.3V	470uF 4V	NONE	220pF	12	30	60	35	3
3.3	2x 10uF 25V	150uF 35V	2 x 100uF 6.3V	330uF 6.3V	NONE	220pF	12	30	60	30	3
3.3	2x 10uF 25V	150uF 35V	4 x 100uF 6.3V	NONE	NONE	220pF	12	32	64	25	3
5	2x 10uF 25V	150uF 35V	1 x 100uF 6.3V	NONE	NONE	100pF	15	80	160	25	3
5	2x 10uF 25V	150uF 35V	1 x 100uF 6.3V	NONE	NONE	100pF	20	80	160	25	3

QUICK START GUIDE FOR DEMONSTRATION CIRCUIT DC1084A-A HIGH DENSITY POWER MODULE

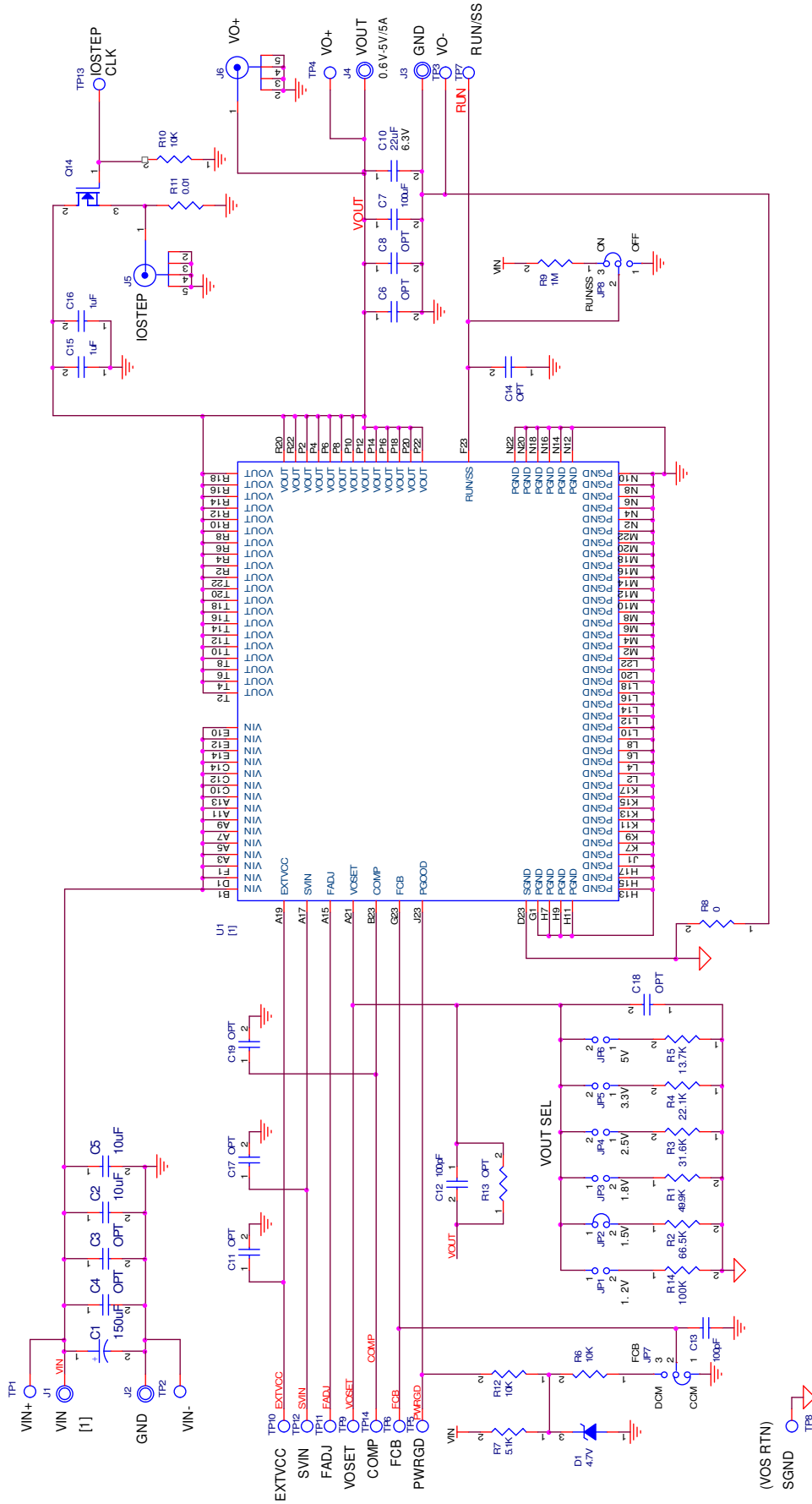

		1600 McCarthy Blvd. Milpitas, CA 95035 Phone: (408)432-1500 Fax: (408)434-0077	
CONTRACT NO.		TITLE	
APPROVALS	DATE	SCH, LTM4602EV/HVEV HIGH EFFICIENCY DC/DC MODULE	
DRAWN MEI	08/04/04	SIZE	Custom
CHECKED	APPROVED	CAGE CODE	DC1084A
ENGINEER	DESIGNER	DWG NO	REV
DO NOT SCALE DRAWING		FILENAME: 1084A-1.DSN	SHEET 1 OF 1
UNLESS OTHERWISE SPECIFIED DIMENSIONS ARE IN INCHES TOLERANCE ON ANGLE 2 INTERPRET DIM AND TOL PER ASME Y14.5M-1994.		SCALE: NONE	OF
THIRD ANGLE PROJECTION		WEDNESDAY, November 01, 2006	1
		SCALE: NONE	1

VERSION	VIN	MODULE
-A	5V-20V	LTM4602EV
-B	5V-28V	LTM4602HVEV

JUMPER	VOUT
JP1	1.2V
JP2	1.5V
JP3	1.8V
JP4	2.5V
JP5	3.3V
JP6	5V

QUICK START GUIDE FOR DEMONSTRATION CIRCUIT DC1084A-A HIGH DENSITY POWER MODULE

DC1084A-A BOM

REQUIRED CIRCUIT COMPONENTS:				
1	1	C1	CAP, 150uF 20% 35V ALUM	SANYO 35MV150WXV
2	2	C5,C2	CAP, 1206 10uF 20% 25V X5R	TDK C3216X5R1E106MT
3	1	C10	CAP, 1206 22uF 20% 6.3V X5R	AVX 12066D266MAT2A
4	1	C7	CAP, 1812 100uF 20% 6.3V X5R	TDK C4532X5R0J107MZ
5	1	C12	CAP, 0603 100pF 10% 50V X7R	AVX 06035C101KAT1A
6	1	R2	RES, 0603 66.5K OHMS 1% 1/10W	AAC CR16-6652FM
7	1	R8	RES, 0603 0 OHM JUMPER	ACC CJ06-000M
1	1	U1	IC, LTM4602EV	LINEAR TECH. LTM4602EV
ADDITIONAL DEMO BOARD CIRCUIT COMPONENTS:				
1	0	C4,C3	CAP, 1206 OPTION	TAIYO YUDEN EMK316BJ475ML-T OPTION
2	0	C8	CAP, 1812 100uF 20% 6.3V X5R OPTION	TDK C4532X5R0J107MZ OPTION
3	0	C6	CAP, 1812 OPTION	TAIYO YUDEN JMK432BJ107MU-T OPTION
4	0	C11,C14,C18,C19	CAP, 0603 OPTION	OPTION
5	1	C13	CAP, 0603 100pF 10% 50V NPO	AVX 06035A101KAT
6	2	C15,C16	CAP, 0603 1uF 20% 10V X5R	TAIYO YUDEN LMK107BJ105MA-T
7	0	C17	CAP, 0805 1uF 20% 16V X5R OPTION	TAIYO YUDEN EMK212BJ105MG-T
8	1	D1	DIODE, ZENER 4.7V	DIODES INC. BZX84C4V7
9	1	Q14	XSTR,SUD50N03-10CP MOSFET	SILICONIX SUD50N03-10CP
10	1	R1	RES, 0603 49.9K OHMS 1% 1/10W	AAC CR16-4992FM
11	1	R3	RES, 0603 31.6K OHMS 1% 1/10W	AAC CR16-3162FM
12	1	R4	RES, 0603 22.1K OHMS 1% 1/10W	AAC CR16-2212FM
13	1	R5	RES, 0603 13.7K OHMS 1% 1/10W	AAC CR16-1372FM
14	3	R6,R10,R12	RES, 0603 10K OHMS 5% 1/10W	VISHAY CRCE060310K0JNEA
15	1	R7	RES, 0603 5.1K OHMS 5% 1/10W	AAC CR16-512JM
16	1	R9	RES, 0603 1M OHMS 5% 1/16W	AAC CR16-105JM
17	1	R11	RES,2512 0.01 OHM 5% 1W	IRC LRF2512-01-R010-J
18	0	R13	RES, 0603 OPTION	OPTION
19	1	R14	RES, 0603 100K OHMS 1% 1/10W	AAC CR16-1003FM
HARDWARE				
	14	TP1-TP14	TURRET	MILL MAX 2501-2-00-80-00-00-07-0
	3	JP1,JP6,JP7	SHUNT, 2mm	SAMTEC 2SN-BK-G
	4		STANDOFF, SNAP ON	KEYSTONE_8831
	6	JP1-JP6	HEADER,2PIN, 2mm	SAMTEC TMM 102-02-L-S
	2	JP7,JP8	HEADER,3PIN, 2mm	SAMTEC TMM-103-02-L-S
	4	J1,J2,J3,J4	JACK, BANANA	KEYSTONE 575-4
	2	J5,J6	CONN,BNC,5 PINS	CONNEX 112404