

## DESCRIPTION

Demonstration circuit 1194 is a 200mA DC/DC converter micromodule buck regulator featuring the LTM8020. The board is optimized for 3.3V output at up to 200mA load current for a steady state input voltage of up to 36V with 40V transient. The minimum startup voltage is higher than the run voltage of 4.5V over the entire current range (see Figure 3). With its wide input voltage range, high efficiency, low dropout operation, hysteretic current-mode, and fully-integrated micromodule package, the LTM8020 is a very versatile and powerful IC for DC/DC converters that require a complete or simple design with compact space, high efficiency and high input voltage.

The LTM8020 hysteretic control scheme provides minimum output ripple voltage at all load currents. The current-mode control topology creates fast transient response and good loop stability with a small output capacitor. The shutdown terminal can be used to place the part in micropower shutdown, reducing supply current to the IC to less than 1 $\mu$ A by driving the terminal low.

The LTM8020 datasheet gives a complete description of the part, operation and applications information. The datasheet must be read in conjunction with this Quick Start Guide for demonstration circuit 1194. In particular, the datasheet section on 'HIGH TEMPERATURE CONSIDERATIONS' is important for estimating whether a given application's combination of input voltage, load current and ambient temperature will cause the LTM8020 to exceed its absolute maximum rated junction temperature. The LTM8020EV is assembled in a 21 Lead LGA (6.25mm x 6.25mm x 2.32mm) micromodule package. Proper board layout is essential for maximum thermal performance. See the

datasheet section 'LAYOUT CONSIDERATIONS'.

**Design files for this circuit board are available. Call the LTC factory.**

LTM is a trademark of Linear Technology Corporation

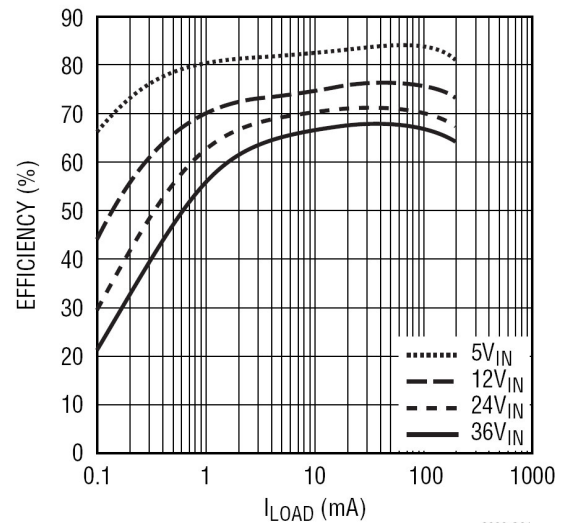

Figure 1. LTM8020EV Efficiency 3.3Vout

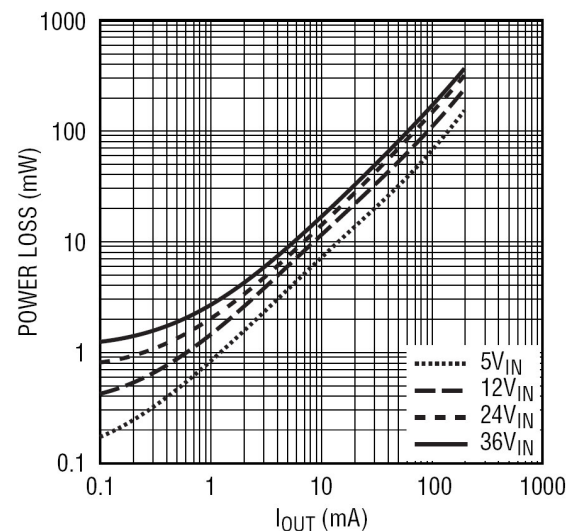

Figure 2. LTM8020EV Power Loss 3.3Vout

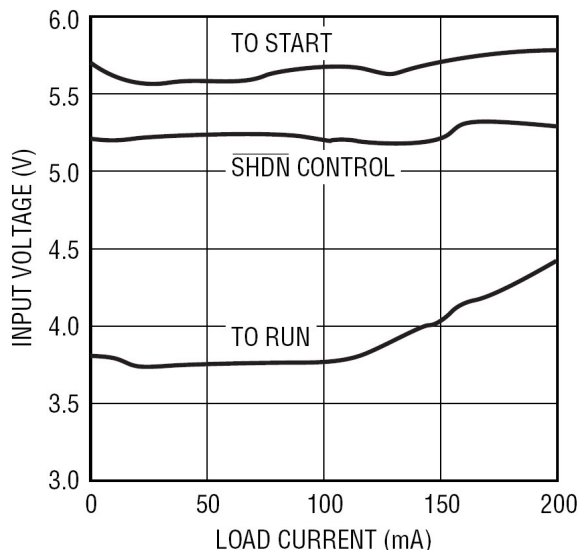

Figure 3. LTM8020EV Typical Minimum VIN 3.3Vout

The DC1194 can be optimized for output voltages other than 3.3V by changing the feedback resistor values, the output capacitor, and the BIAS pin

connection. As built, the BIAS pin of the LTM8020 is tied directly to VOUT. The BIAS pin of the IC can be disconnected from VOUT by making a small cut on the PCB. After that, the BIAS terminal can be connected in a number of different ways for each design. Please see the datasheet section on 'BIAS PIN CONSIDERATIONS' for details.

## QUICK START PROCEDURE

Demonstration circuit 1194 is easy to set up to evaluate the performance of the LTM8020. Refer to Figure 4 for proper measurement equipment setup and follow the procedure below:

**NOTE:** Do not hot-plug the input voltage terminal VIN. The absolute maximum voltage on VIN is 40V and hot-plugging a power supply through wire leads to the demonstration circuit can cause the voltage on the extremely low-ESR ceramic input capacitor to ring to twice its DC value. In order to protect the IC, a higher ESR Aluminum Electrolytic capacitor is placed at the input terminals. This may protect against some, but not all, input transients due to hot-plugging with a power supply. See *Application Note 88* for more details..

1. Connect the power supply (with power off), load, and meters as shown in Figure 4.
2. After all connections are made, turn on input power and verify that the output voltage is 3.3V.
 

**NOTE:** If the output voltage is too low, temporarily disconnect the load to make sure that the load is not set too high.
3. Once the proper output voltage is established, adjust the load within the operating range and observe the output voltage regulation, ripple voltage, efficiency and other parameters.

# QUICK START GUIDE FOR DEMONSTRATION CIRCUIT 1194

## 200mA DC/DC MICROMODULE

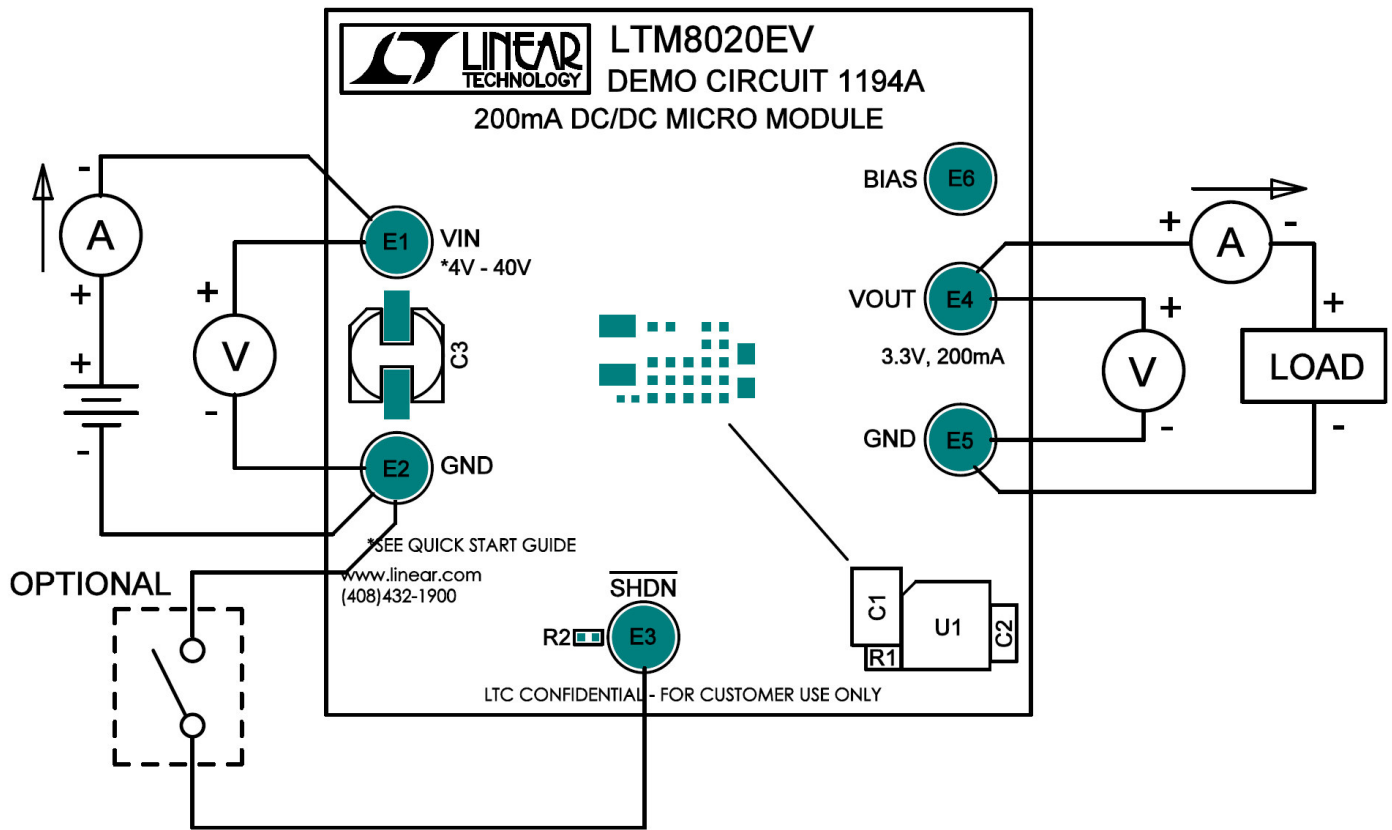

Figure 4. Proper Measurement Equipment Setup

# QUICK START GUIDE FOR DEMONSTRATION CIRCUIT 1194

## 200mA DC/DC MICROMODULE

This circuit is proprietary to Linear Technology and supplied for use with Linear Technology parts.

**Customer Notice:** Linear Technology has made a best effort to design a circuit that meets customer-supplied specifications; however, it remains the customer's responsibility to verify proper and reliable operation in the actual application. Component substitution and printed circuit board layout may significantly affect circuit performance or reliability. Contact Linear Applications Engineering for assistance.

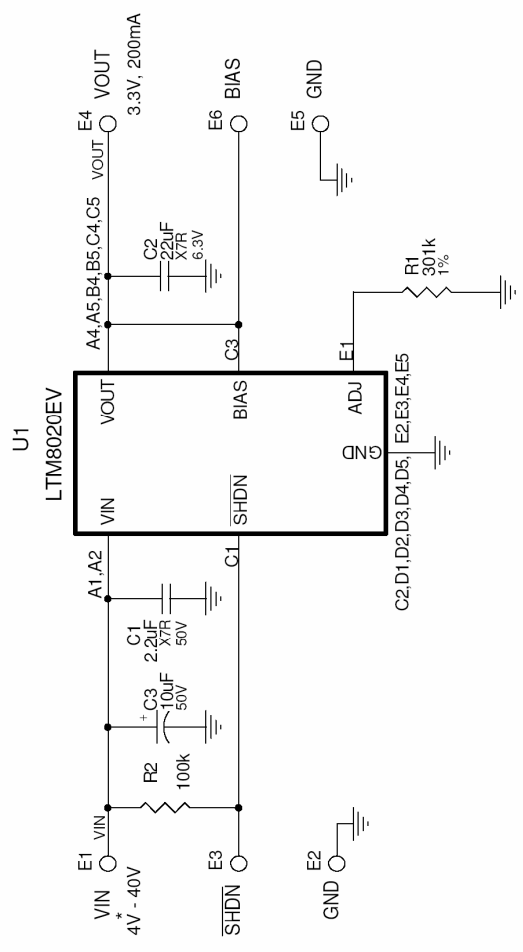

REVISION HISTORY				
ECO	REV	DESCRIPTION	DATE	APPROVED
	A	PROTO	10/25/07	

CONTRACT NO.		1630 McCarthy Blvd. Milpitas, CA 95035 Phone: (408)432-1900 Fax: (408)434-0507	
APPROVALS	DATE	TITLE	
DRAWN MEI	11/28/06	SCH, LTM8020EV, 200mA DC/DC MICRO MODULE	
CHECKED		SIZE	CAGE CODE
APPROVED		ENGINEER	DWG NO
DESIGNER		DC1194A	REV A
Thursday, November 01, 2007	SCALE:	FILENAME: 1194A-2.DSN	SHEET 1 OF 1

\* SEE QUICK-START GUIDE

