

# 42V, 6A Micropower Synchronous Step-Down Regulator

## DESCRIPTION

Demonstration circuit 2010A is a 42V, 6A micropower synchronous step-down regulator featuring the LT<sup>®</sup>8612. The demo board is designed for 5V output from a 5.8V to 42V input. The wide input range allows a variety of input sources, such as automotive batteries and industrial supplies. The LT8612 is a compact, high efficiency, and high speed synchronous monolithic step-down switching regulator. The integrated power switches and inclusion of all necessary circuitry reduce the components count and solution size. Ultralow 3 $\mu$ A quiescent current in Burst Mode<sup>®</sup> operation achieves high efficiency at very light loads. Fast minimum on-time of 40ns enables high  $V_{IN}$  to low  $V_{OUT}$  conversion at high frequency.

The LT8612 switching frequency can be programmed either via oscillator resistor or external clock over a 200kHz to 2.2MHz range. The SYNC pin on the demo board is grounded by default for low ripple burst mode operation. To synchronize to an external clock, move JP1 to SYNC and apply the external clock to the SYNC turret. Once JP1 is on SYNC position, a DC voltage of 3V or higher can be applied to the SYNC turret for pulse-skipping operation.

Figure 1 shows the efficiency of DC2010A circuit at 12V input. Figure 2 shows the LT8612 temperature rising on DC2010A demo board under different load conditions. The rated maximum load current is 6A, while derating is necessary for certain  $V_{IN}$  and thermal conditions. The demo board has an EMI filter installed. To use the EMI filter, the input should be tied to VEMI terminal, not VIN terminal.

The LT8612 data sheet gives a complete description of the part, operation and application information. The data sheet must be read in conjunction with this demo manual for demo circuit 2010A. The LT8612 is assembled in a 3mm  $\times$  6mm plastic QFN package with exposed pads for low thermal resistance. Proper board layout is essential for minimum EMI and maximum thermal performance. See the data sheet section PCB Layout and High Temperature Considerations.

**Design files for this circuit board are available at <http://www.linear.com/demo/DC2010A>**

LT, LT, LTC, LTM, Linear Technology, Burst Mode and the Linear logo are registered trademarks of Linear Technology Corporation. All other trademarks are the property of their respective owners.

## PERFORMANCE SUMMARY Specifications are at $T_A = 25^\circ\text{C}$

SYMBOL	PARAMETER	CONDITIONS	MIN	TYP	MAX	UNITS
$V_{IN}$	Input Supply Range		5.8		42	V
$V_{OUT}$	Output Voltage		4.875	5	5.125	V
$I_{OUT}$	Maximum Output Current	Derating Is Necessary for Certain $V_{IN}$ and Thermal Conditions	6			A
$f_{SW}$	Switching Frequency		665	700	735	MHz
EFE	Efficiency at DC	$V_{IN} = 12\text{V}$ , $I_{OUT} = 3\text{A}$		94.3		%

## DESCRIPTION

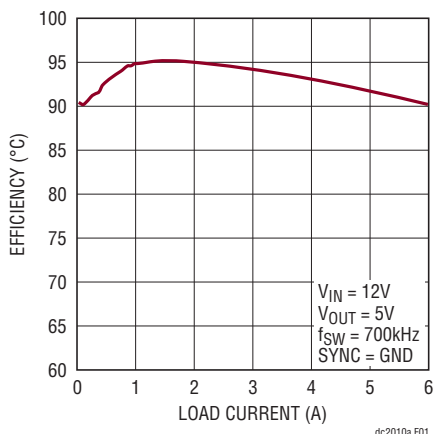

Figure 1. Efficiency vs Load Current (Using VIN Terminal)

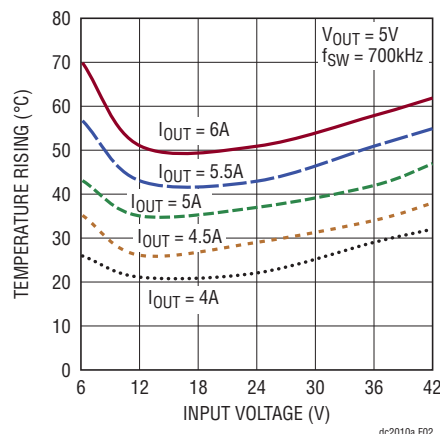

Figure 2. Temperature Rising vs Input Voltage

## QUICK START PROCEDURE

Demonstration circuit 2010A is easy to set up to evaluate the performance of the LT8612. Refer to Figure 3 for proper measurement equipment setup and follow the procedure below:

NOTE. When measuring the input or output voltage ripple, care must be taken to avoid a long ground lead on the oscilloscope probe. Measure the input or output voltage ripple by touching the probe tip directly across the VIN or VOUT and GND terminals. See Figure 4 for the proper scope technique.

1. Place JP1 on GND position.
2. With power off, connect the input power supply to VIN and GND.
3. With power off, connect the load from VOUT to GND.
4. Turn on the power at the input.

NOTE. Make sure that the input voltage does not exceed 42V.

5. Check for the proper output voltage ( $V_{OUT} = 5V$ ).

NOTE. If there is no output, temporarily disconnect the load to make sure that the load is not set too high or is shorted.

6. Once the proper output voltage is established, adjust the load within the operating ranges and observe the output voltage regulation, ripple voltage, efficiency and other parameters.
7. An external clock can be added to the SYNC terminal when SYNC function is used (JP1 on the SYNC position). Please make sure that  $R_T$  should be chosen to set the LT8612 switching frequency equal to or below the lowest SYNC frequency. See the data sheet section Synchronization.

**QUICK START PROCEDURE**

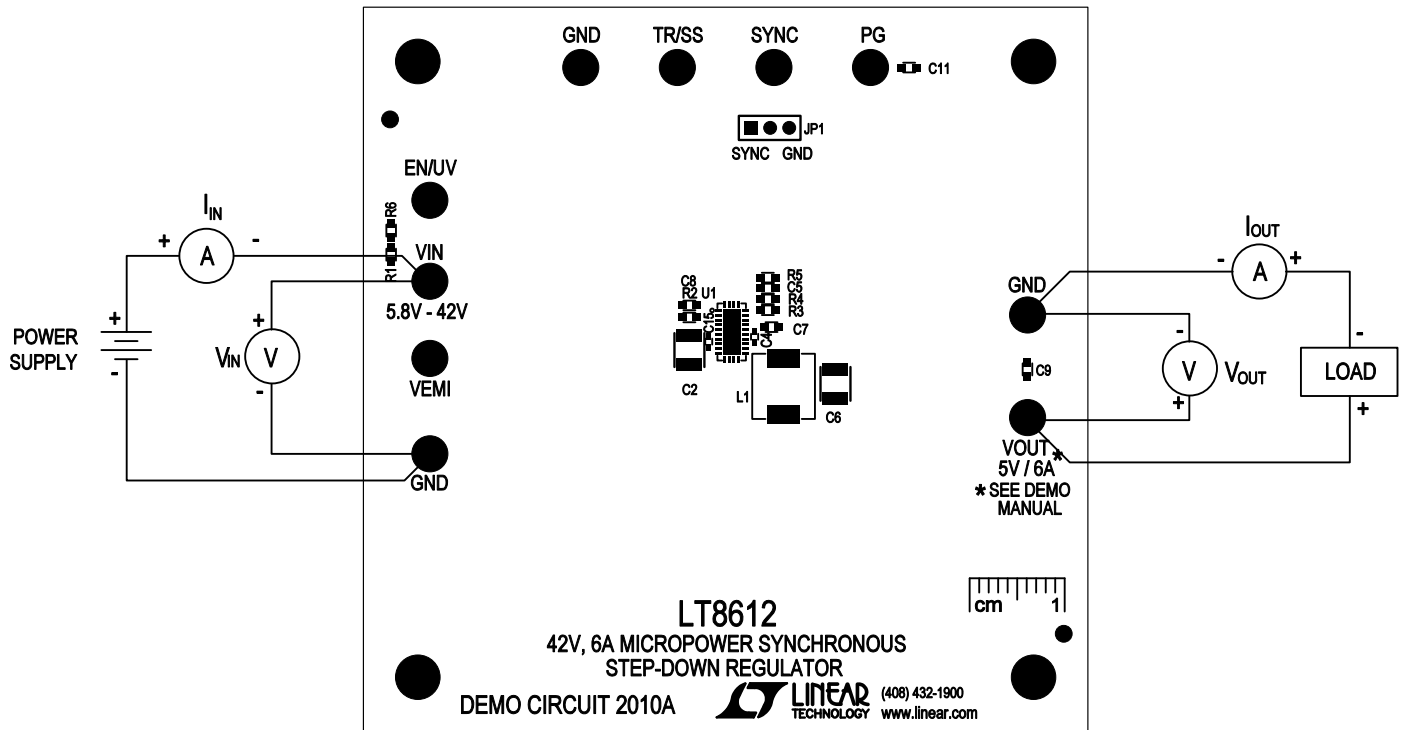

Figure 3. Proper Measurement Equipment Setup

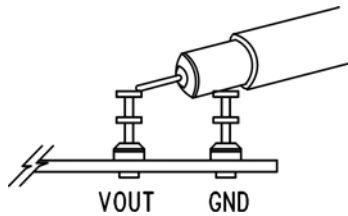

Figure 4. Measuring Output Ripple

# DEMO MANUAL DC2010A

## PARTS LIST

ITEM	QTY	REFERENCE	PART DESCRIPTION	MANUFACTURER/PART NUMBER
<b>Required Circuit Components</b>				
1	1	C2	CAP., X5R, 10µF, 50V, 10% 1210	MURATA, GRM32ER61H106KA12L
2	1	C8	CAP., X7R, 0.1µF, 25V, 10% 0603	MURATA, GRM188R71E104KA01D
3	1	C5	CAP., C0G, 10pF, 25V, 5% 0603	AVX, 06033A100JAT2A
4	1	C6	CAP., X5R, 100µF, 10V, 20% 1210	SAMSUNG, CL32A107MPVNNNE
5	2	C7, C9	CAP., X7R, 1.0µF, 25V, 10% 0603	MURATA, GRM188R71E105KA12D
6	2	C4, C15	CAP., X7R, 0.1µF, 50V, 10% 0402	TDK, C1005X7R1H104K
7	1	L1	IND., 3.3µH, IHLP2525EZ-01	VISHAY, IHLP2525EZER3R3M01
8	2	R1, R3	RES., CHIP., 100k, 1/10W, 1% 0603	VISHAY, CRCW0603100KFKEA
9	1	R2	RES., CHIP., 60.4k, 1/10W, 1% 0603	VISHAY, CRCW060360K4FKEA
10	1	R4	RES., CHIP., 1M, 1/10W, 1% 0603	VISHAY, CRCW06031M00FKEA
11	1	R5	RES., CHIP., 243k, 1/10W, 1%, 0603	VISHAY, CRCW0603243KFKEA
12	1	U1	IC, REGULATOR, 28-QFN, UDE	LINEAR TECH., LT8612EUDE#PBF
<b>Additional Demo Board Circuit Components</b>				
1	1	C1	CAP., ALUM 22µF, 63V	SUN ELECT., 63CE22BS
2	2	C3, C10	CAP., X5R, 10µF, 50V, 10% 1210	MURATA, GRM32ER61H106KA12L
3	1	C14	CAP., X7R, 0.1µF, 50V, 10% 0402	TDK, C1005X7R1H104K
4	0	C11 (OPT)	CAP., 0603	
5	1	L2	FERRITE BEAD 100Ω 8A SMD 1812	WURTH, 74279226101
6	1	L3	IND., 6.8µH, IHLP3232DZ-11	VISHAY, IHLP3232DZER6R8M11
7	0	R6 (OPT)	RES., 0402	
8	1	R7	RES., CHIP., 0Ω, 1/10W, 1%, 0603	VISHAY, CRCW06030000Z0EA
<b>Hardware: For Demo Board Only</b>				
1	10	E1-E10	TESTPOINT, TURRET, 0.094"	MILL-MAX, 2501-2-00-80-00-00-07-0
2	1	JP1	HEADER, 3 PIN 0.079" SINGLE ROW	SULLINS, NRPNO31PAEN-RC
3	1	XJP1	SHUNT, 0.079" CENTER	SAMTEC, 2SN-BK-G
4	4	MH1-MH4	STAND-OFF, NYLON 0.50" TALL	KEYSTONE, 8833(SNAP ON)

**SCHEMATIC DIAGRAM**

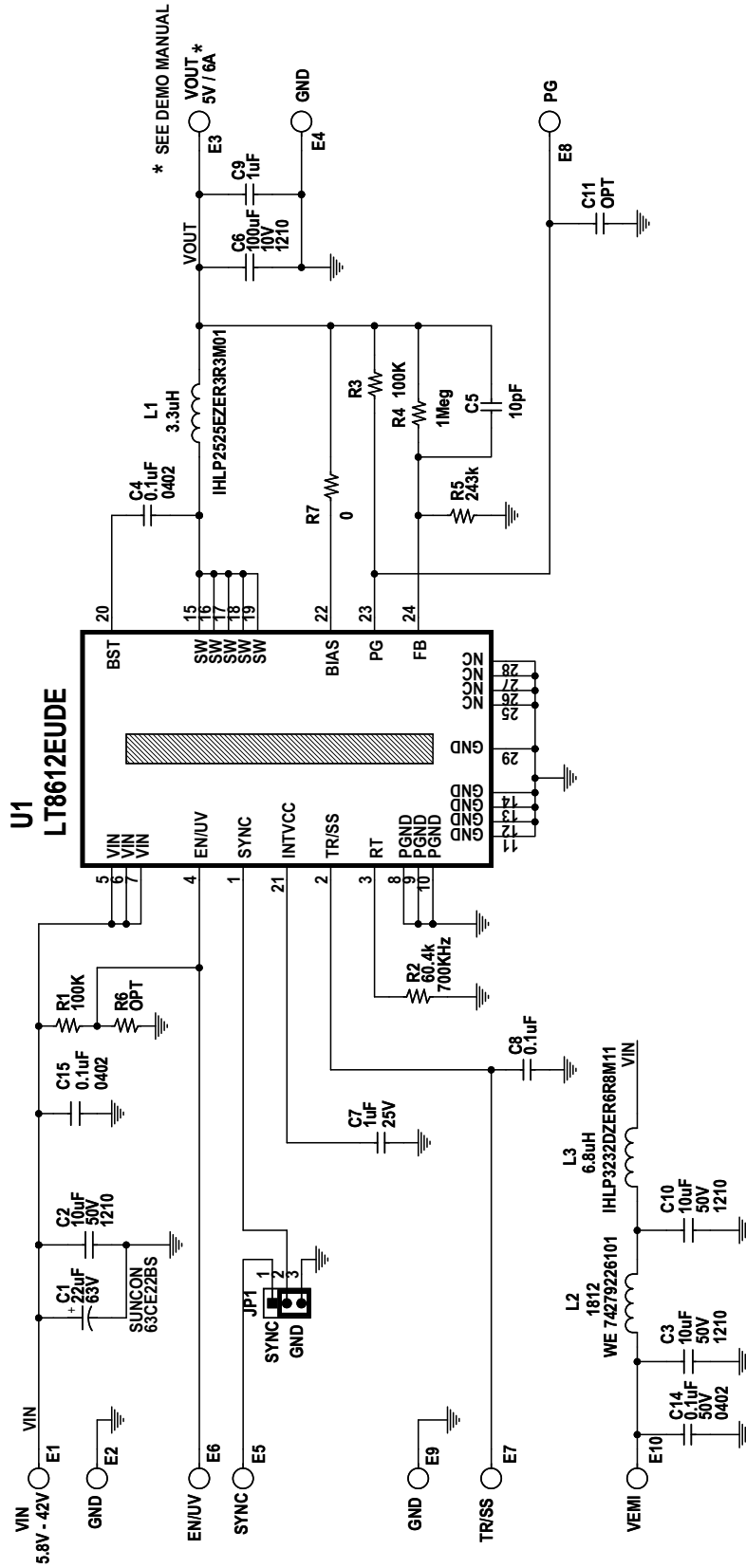

**NOTES: UNLESS OTHERWISE SPECIFIED**

1. ALL RESISTORS ARE 0603.
- ALL CAPACITORS ARE 0603.

# DEMO MANUAL DC2010A

---

## DEMONSTRATION BOARD IMPORTANT NOTICE

Linear Technology Corporation (LTC) provides the enclosed product(s) under the following **AS IS** conditions:

This demonstration board (DEMO BOARD) kit being sold or provided by Linear Technology is intended for use for **ENGINEERING DEVELOPMENT OR EVALUATION PURPOSES ONLY** and is not provided by LTC for commercial use. As such, the DEMO BOARD herein may not be complete in terms of required design-, marketing-, and/or manufacturing-related protective considerations, including but not limited to product safety measures typically found in finished commercial goods. As a prototype, this product does not fall within the scope of the European Union directive on electromagnetic compatibility and therefore may or may not meet the technical requirements of the directive, or other regulations.

If this evaluation kit does not meet the specifications recited in the DEMO BOARD manual the kit may be returned within 30 days from the date of delivery for a full refund. **THE FOREGOING WARRANTY IS THE EXCLUSIVE WARRANTY MADE BY THE SELLER TO BUYER AND IS IN LIEU OF ALL OTHER WARRANTIES, EXPRESSED, IMPLIED, OR STATUTORY, INCLUDING ANY WARRANTY OF MERCHANTABILITY OR FITNESS FOR ANY PARTICULAR PURPOSE. EXCEPT TO THE EXTENT OF THIS INDEMNITY, NEITHER PARTY SHALL BE LIABLE TO THE OTHER FOR ANY INDIRECT, SPECIAL, INCIDENTAL, OR CONSEQUENTIAL DAMAGES.**

The user assumes all responsibility and liability for proper and safe handling of the goods. Further, the user releases LTC from all claims arising from the handling or use of the goods. Due to the open construction of the product, it is the user's responsibility to take any and all appropriate precautions with regard to electrostatic discharge. Also be aware that the products herein may not be regulatory compliant or agency certified (FCC, UL, CE, etc.).

No License is granted under any patent right or other intellectual property whatsoever. **LTC assumes no liability for applications assistance, customer product design, software performance, or infringement of patents or any other intellectual property rights of any kind.**

LTC currently services a variety of customers for products around the world, and therefore this transaction **is not exclusive**.

**Please read the DEMO BOARD manual prior to handling the product.** Persons handling this product must have electronics training and observe good laboratory practice standards. **Common sense is encouraged.**

This notice contains important safety information about temperatures and voltages. For further safety concerns, please contact a LTC application engineer.

Mailing Address:

Linear Technology  
1630 McCarthy Blvd.  
Milpitas, CA 95035

Copyright © 2004, Linear Technology Corporation