

## Evaluation Board for a Quad-Channel, 16-Bit, Serial Input, 4 mA to 20 mA, Voltage Output DAC with Dynamic Power Control and HART Connectivity

### FEATURES

Full-featured evaluation board for the [AD5755](#), [AD5755-1](#), [AD5757](#), and

Link options

PC control in conjunction with Analog Devices, Inc., system demonstration platform (SDP)

PC software for control

### GENERAL DESCRIPTION

The EVAL-AD575xSDZ is a full-featured evaluation board that is designed to allow the user to easily evaluate all features of the [AD5755](#), [AD5755-1](#), or [AD5757](#), quad channel, 16-bit current source and voltage output DAC with dynamic power control and HART connectivity. The board can be controlled by two means: via the on-board connector (J11) or via the SDP connector (J9). The SDP board allows the evaluation board to be controlled through the USB port of a Windows® XP® (SP2 or later) or Windows Vista® (32-bit or 64-bit) or Windows 7 (32-bit or 64-bit) based PC using the EVAL-AD575xSDZ evaluation software.

### DEVICE DESCRIPTION

The [AD5755](#) is a quad, voltage and current output DAC that operates with a power supply range from  $-26.4\text{ V}$  to  $+33\text{ V}$ . On-chip dynamic power control minimizes package power dissipation in current mode. This is achieved by regulating the voltage on the output driver from  $7.4\text{ V}$  to  $29.5\text{ V}$ .

The part uses a versatile 3-wire serial interface that operates at clock rates up to  $30\text{ MHz}$  and is compatible with standard SPI, QSPI™, MICROWIRE™, DSP, and microcontroller interface standards. The interface also features optional CRC-8 packet error checking, as well as a watchdog timer that monitors activity on the interface.

The [AD5757](#) is a current output-only version of the [AD5755](#) and is HART compatible. The [AD5755-1](#) is identical to the [AD5755](#) except the  $-V_{\text{SENSE}_x}$  functionality has been removed and, instead, the device is HART compatible. For both the [AD5757](#) and [AD5755-1](#), each channel has a corresponding CHART pin so that HART signals can be coupled onto the current output.

### EVALUATION BOARD CONNECTION DIAGRAM

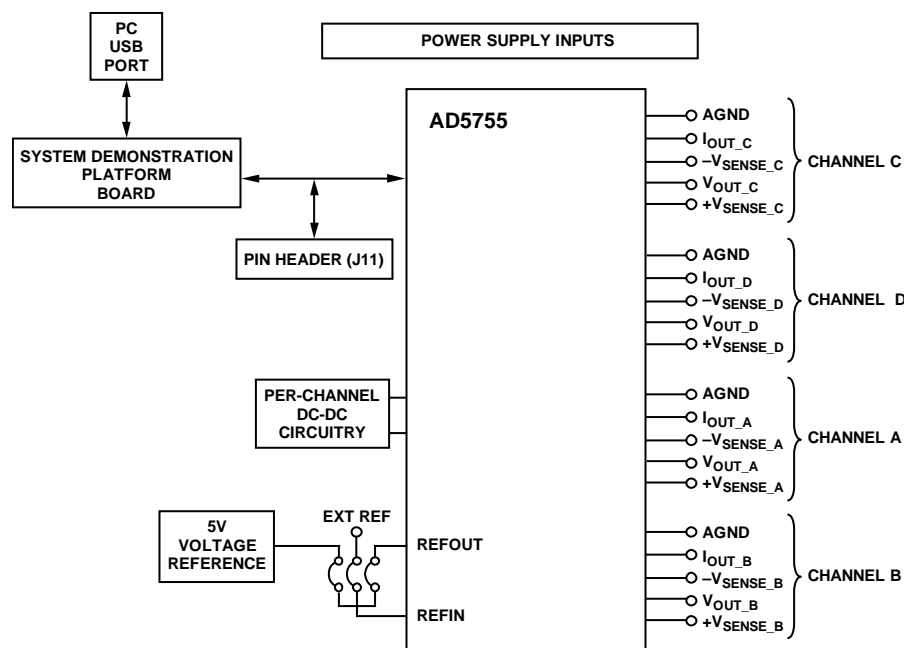

Figure 1.

**TABLE OF CONTENTS**

Features .....	1	Changing and Reprogramming the Range .....	6
General Description .....	1	Clear Command .....	6
Device Description .....	1	Control of Digital Pins .....	7
Evaluation Board Connection Diagram .....	1	Writing to Data Registers .....	7
Revision History .....	2	Reading from Registers .....	7
Evaluation Board Hardware .....	3	Writing to the DAC Control Registers .....	7
Power Supplies .....	3	Writing to the DC-to-DC Control Register .....	8
Link Options .....	3	Writing to the Main Control Register .....	8
Output Connectors .....	4	Writing to the Slew Rate Control Register .....	8
DC-to-DC Boost .....	4	Software Register .....	9
Patchwork .....	4	PEC .....	9
System Demonstration Platform (SDP) .....	4	Status Readback .....	9
Evaluation Board Software .....	5	Evaluation Board Schematics and Artwork .....	10
Software Installation .....	5	Ordering Information .....	15
Software Operation .....	5	Bill of Materials .....	15
Selecting the Device .....	6	Related Links .....	15
Enabling the Output Correctly .....	6		

**REVISION HISTORY**

**6/11—Rev. 0 to Rev. A**

Added AD5755 and AD5757 .....	Universal
Changes to Table 2 .....	3
Added Table 5 and Table 6; Renumbered Sequentially;	
Changes to Table 6, and Changes to Patchwork Section .....	4
Changes to Bill of Materials Section and Related Links	
Section .....	15

**5/11—Revision 0: Initial Version**

## EVALUATION BOARD HARDWARE

### POWER SUPPLIES

The following power supplies are required.

**Table 1. Power Supply Connections**

Connector	Nominal	Comment
AV <sub>DD</sub>	15 V	Positive analog supply voltage. 10.8 V to 33 V range. (Green LED D2 lights up when power is supplied to AV <sub>DD</sub> .)
AV <sub>SS</sub>	-15 V/ +0 V	Negative analog supply voltage. +10.8 V to -26.4 V range, or 0 V for the AD5757 or AD5755-1 in unipolar supply mode.
AV <sub>CC</sub>	5 V	DC-to-dc supply voltage. 2.7 V to 5.5 V range. The AV <sub>CC</sub> input supplies all four on-board dc-to-dc blocks and may draw as much as 0.8 A peak current per channel, depending on the configuration (see the device data sheet for more information).
DV <sub>DD</sub>	3.3 V	Supplied from the SDP connector. 2.7 V to 5.5 V range.
REFIN	5 V	See Table 3 for selecting the reference source: the AD575x internal reference, the on-board ADR02 reference, or externally provided via the REFIN input.

Both analog AGND and PGND inputs are provided on the board. The PGND input is for the ground of the dc-to-dc converter circuitry, and a ground connection for the AV<sub>CC</sub> supply should be made at this point. The AGND and PGND planes are connected at one location on the evaluation board.

The AGND and DGND planes are connected at one location close to the AD5755, AD5755-1, or AD5757 device. Each supply is decoupled to the relevant ground plane with 10 μF and 0.1 μF capacitors. Each device supply pin is also decoupled with a 10 μF and 0.1 μF capacitor pair to the relevant ground plane.

### LINK OPTIONS

The link options on the evaluation board should be set for the required operating setup before using the board. The functions of the link options are described in Table 3.

#### Default Link Option Setup

The default link options are listed in Table 2.

**Table 2. Default Link Options**

Link No.	AD5755 Link Setup	AD5755-1 Link Setup	AD5757 Link Setup
LK0	Removed	Removed	Removed
LK1	Removed	Removed	Removed
LK2	Inserted	Inserted	Inserted
LK3	Inserted	Inserted	Inserted
LK4	Inserted	Inserted	Removed
LK5	Inserted	Removed	Removed
LK6	Inserted	Inserted	Removed
LK7	Inserted	Removed	Removed
LK8	Inserted	Inserted	Removed
LK9	Inserted	Removed	Removed
LK10	Inserted	Inserted	Removed
LK11	Inserted	Removed	Removed
LK12	Removed	Removed	Removed
LK13	Removed	Removed	Removed
LK14	Removed	Removed	Removed
LK15	Removed	Removed	Removed

**Table 3. Link Options**

Link No.	Device	Description
LK0, LK1, LK2	All Models	These links select the voltage reference source (only one of these should be inserted at any one time). LK0 selects the internal voltage reference of the AD575x as the voltage reference source. LK1 selects an external voltage reference source that can be applied at Connector J7. LK2 selects the on-board ADR02 as the voltage reference source. The ADR02 is supplied by the AV <sub>DD</sub> supply and operates under the same input voltage range as the AV <sub>DD</sub> input of the AD575x, that is 9 V to 33 V.
LK3	All Models	Powers the on-board ADR02 5 V reference by connecting the AV <sub>DD</sub> supply to the ADR02 supply pin.
LK4, LK6 LK10, LK8,	AD5755, AD5755-1	These links connect the +V <sub>SENSE</sub> input to V <sub>OUT</sub> for Channel A, Channel B, Channel C, and Channel D, respectively. When this link is inserted, the +V <sub>SENSE</sub> input is connected directly to the V <sub>OUTX</sub> pin. When this link is removed, the +V <sub>SENSE</sub> input is left floating and should be connected to the high-side of the load resistance external to the evaluation board.
LK5, LK7 LK9, LK11,	AD5755	These links connect the +V <sub>SENSE</sub> input to V <sub>OUT</sub> for Channel A, Channel B, Channel C, and Channel D, respectively. When this link is inserted, the +V <sub>SENSE</sub> input is connected directly to the V <sub>OUT</sub> pin. When this link is removed, the +V <sub>SENSE</sub> input is left floating and should be connected to the high-side of the load resistance external to the evaluation board.
LK12, LK13, LK14, LK15	All Models	These links allow connection of an external V <sub>BOOST</sub> supply. (Remove Resistors R43, R44, R17, and R20 to use this feature.) When inserted, these connect the V <sub>BOOST</sub> pin of Channel A, Channel B, Channel C, and Channel D, respectively, to the AV <sub>DD</sub> supply. When removed, the V <sub>BOOST</sub> supplies are controlled by the dc-to-dc converter circuitry.

**Connector J11 Pin Descriptions**

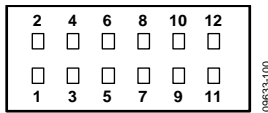

Figure 2. Connector J11 Pin Configuration

**Table 4. Connector J11 Pin Descriptions<sup>1</sup>**

Pin No.	Description
1	DV <sub>DD</sub>
2	DGND
3	SYNC
4	SCLK
5	SDIN
6	SDO (output)
7	LDAC
8	CLEAR
9	POC (AD5755 and AD5755-1)
10	RESET
11	FAULT (output)
12	ALERT (output)

<sup>1</sup> The SDP board must be disconnected when using the J11 connector.

**OUTPUT CONNECTORS**

There are five connectors per channel on the EVAL-AD575xSDZ PCB. The output connectors are used as outlined in Table 5, Table 6, and Table 7.

**Table 5. On-Board Connectors for AD5755**

Connector	Function
GND	There is a per-channel connection to AGND.
A1, B1, C1, D1	I <sub>OUT</sub> output for Channel A, Channel B, Channel C, and Channel D, respectively.
A2, B2, C2, D2	-V <sub>SENSE</sub> input for Channel A, Channel B, Channel C, and Channel D, respectively.
A3, B3, C3, D3	V <sub>OUT</sub> output for Channel A, Channel B, Channel C, and Channel D, respectively.
A4, B4, C4, D4	+V <sub>SENSE</sub> input for Channel A, Channel B, Channel C, and Channel D, respectively.

**Table 6. On-Board Connectors for AD5757**

Connector	Function
GND	There is a per-channel connection to AGND.
A1, B1, C1, D1	I <sub>OUT</sub> output for Channel A, Channel B, Channel C, and Channel D, respectively.
A2, B2, C2, D2	CHART input for Channel A, Channel B, Channel C, and Channel D, respectively. HART signals should be capacitively coupled onto these pins as described in the AD5757 data sheet.
A4, B3, C3, D4	Connection to the IGATE <sub>x</sub> pin
A3, B4, C4, D3	Not used.

**Table 7. On-Board Connectors for AD5755-1**

Connector	Function
GND	There is a per-channel connection to AGND.
A1, B1, C1, D1	I <sub>OUT</sub> output for Channel A, Channel B, Channel C, and Channel D, respectively.
A2, B2, C2, D2	CHART input for Channel A, Channel B, Channel C, and Channel D, respectively. HART signals should be capacitively coupled onto these pins as described in the AD5755-1 data sheet.
A3, B3, C3, D3	V <sub>OUT</sub> output for Channel A, Channel B, Channel C, and Channel D, respectively.
A4, B4, C4, D4	+V <sub>SENSE</sub> input for Channel A, Channel B, Channel C, and Channel D, respectively.

**DC-TO-DC BOOST**

Each channel has a dc-to-dc boost converter. This consists of a Schottky diode, inductor, and a low ESR, high voltage capacitor. A low-pass RC filter is also included on a per-channel basis.

**Table 8. DC-to-DC Circuitry**

Symbol	Component	Value	Manufacturer
L <sub>DCDC</sub>	XAL4040-103	10 μH	Coilcraft
C <sub>DCDC</sub>	GRM32ER71H475KA88L	4.7 μF	Murata
D <sub>DCDC</sub>	PMEG3010BEA	0.38 V <sub>F</sub>	NXP
R <sub>FILTER</sub>	N/A	10 Ω	N/A
C <sub>FILTER</sub>	N/A	0.1 μF	N/A

The L<sub>DCDC</sub> 10 μH inductor provides the best performance at the 410 kHz switching frequency. Consult the AD5755, AD5755-1, AD5757, or data sheet for more information on the dc-to-dc converter circuitry.

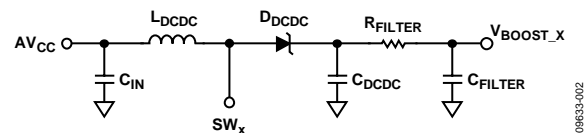

Figure 3. DC-to-DC Converter Circuitry

**PATCHWORK**

Patchwork is included on the EVAL-AD575xSDZ near the output connectors. This is connected in rows with one row connected to AGND per channel and one row connected to I<sub>OUT</sub> per channel. All other rows are left floating.

When evaluating the EVAL-AD5757SDZ, the patchwork gives access to the drain, gate and source of a discreet PMOS transistor which can be used to evaluate the IGATE functionality.

**SYSTEM DEMONSTRATION PLATFORM (SDP)**

The EVAL-AD575xSDZ board can connect to the SDP board via the J9 connector. The SDP is a hardware and software platform that provides a means to communicate from the PC to supported Analog Devices products and systems that require digital control and/or readback. The SDP has a Blackfin® (BF527) at its core. This has on-chip USB 2.0 capabilities as well as many external interface ports, such as SPI, SPORT, I<sup>2</sup>C, and a 16-bit parallel interface. See Figure 20 for connections made to the SDP board.

# EVALUATION BOARD SOFTWARE

## SOFTWARE INSTALLATION

The EVAL-AD575xSDZ evaluation kit includes self-installing software on a CD. The software is compatible with Windows XP (SP2) and Windows Vista (32-bit or 64-bit), and Windows 7 (32-bit or 64-bit). If the setup file does not run automatically, you can run **setup.exe** from the CD.

Install the evaluation software before connecting the evaluation board and SDP board to the USB port of the PC to ensure that the evaluation system is correctly recognized when connected to the PC.

1. After installation from the CD is complete, power up the EVAL-AD575xSDZ as described in the Power Supplies section.
2. Next, connect the SDP board to the EVAL-AD575xSDZ and then to the USB port of your PC using the supplied cable.
3. When the evaluation system is detected, proceed through any dialog boxes that appear. This finishes the installation.

## SOFTWARE OPERATION

To launch the software, complete the following steps:

1. From the **Start** menu, select **Analog Devices –AD5755 AD5757 AD5755-1**, and then select **AD5755 AD5757**

**AD5755-1 Evaluation Software.** The main window of the software opens (see Figure 5).

2. If the evaluation system is not connected to the USB port when the software is launched, a connectivity error is displayed (see Figure 4). Simply connect the evaluation board to the USB port of the PC, wait a number of seconds, and click **Rescan**. Follow the instructions.

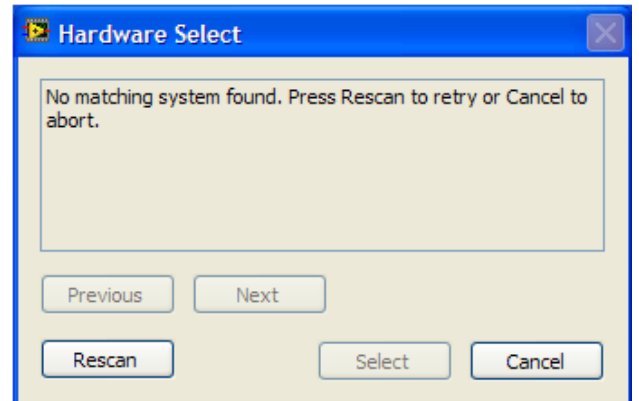

Figure 4. Connectivity Error Alert



Figure 5. Main Window

**SELECTING THE DEVICE**



Figure 6. Device Selection

In the top left corner of the main window, select the main device on the board, either AD5755, AD5755-1, or AD5757, from the drop-down list (see Figure 6) to adjust the available controls accordingly.

**ENABLING THE OUTPUT CORRECTLY**

To correctly write to and set up the part from a power-on condition, use the following sequence.

1. Perform a hardware or software reset after initial power-on.
2. The dc-to-dc converter supply block must be configured. Set the dc-to-dc switching frequency, maximum output voltage allowed, and the phase that the four dc-to-dc channels clock at.
3. Configure the DAC control register on a per channel basis. The output range is selected, and the dc-to-dc converter block is enabled (DC\_DC bit). Other control bits can be configured at this point. Set the INT\_ENABLE bit; however, the output enable bit (OUTEN) should not be set.
4. Write the required code to the DAC data register. This implements a full DAC calibration internally. Allow at least 200 μs before Step 5 for reduced output glitch.
5. Write to the DAC control register again to enable the output (set the OUTEN bit).

A flowchart of this sequence is shown in Figure 7.

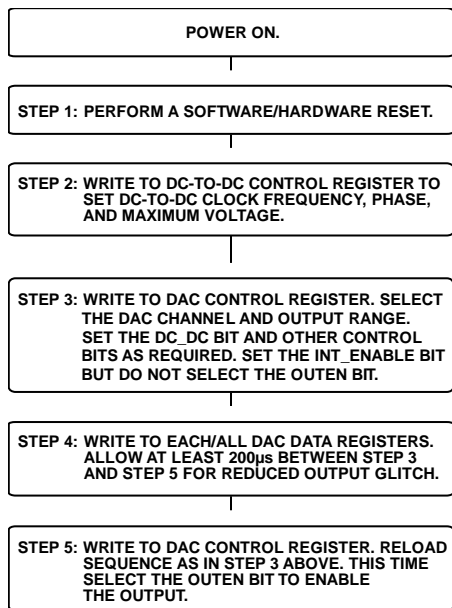

Figure 7. Programming Sequence for Enabling the Output Correctly

**CHANGING AND REPROGRAMMING THE RANGE**

When changing between ranges, the same sequence as described in the Enabling the Output Correctly section should be used. It is recommended to set the range to its zero point (can be midscale or zero scale) prior to disabling the output. Because the dc-to-dc converter switching frequency, maximum voltage, and phase have already been selected, there is no need to reprogram these. A flowchart of this sequence is shown in Figure 8.

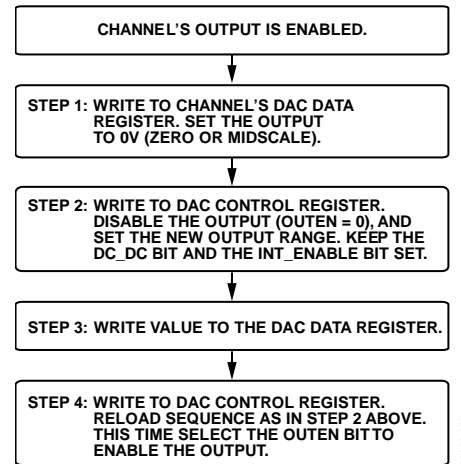

Figure 8. Steps for Changing the Output Range

**CLEAR COMMAND**

To clear an output, each relevant channel must have its clear code set in the relevant data register (default of 0x0000) and be enabled for clear operation via the DAC control registers. After these are set, assert the CLEAR pin to clear the selected channels.

**CONTROL OF DIGITAL PINS**

The RESET, LDAC, POC, and ALERT pins can all be controlled by clicking the relevant boxes shown in Figure 9. The FAULT and ALERT boxes display the status of the ALERT and FAULT pins. The FAULT and ALERT pins of the device are polled by the evaluation software every ~100 ms. The FAULT pin is also connected to the reference LED, D1, on the evaluations board, and ALERT is connected to the orange LED, D14.

**WRITING TO DATA REGISTERS**

This function allows you to write to all the data registers. Select the register to write to from the pull-down menu, enter the 16-bit data-word to be written (in hexadecimal) and click WRITE to load data to the register. Note that the gain and offset registers do not update until the DAC has been written to.

**READING FROM REGISTERS**

This function allows you to read from all the data registers, control registers, and the status register. Select the register to read from the pull-down menu and click READ. The 16 bits of LSB data appear in the number box in hexadecimal format.

**WRITING TO THE DAC CONTROL REGISTERS**

This function allows you to write to and configure the DAC control register for a selected channel. Select the required DAC channel to be configured from the pull-down menu. After configuring the settings you require, click WRITE to write to the device. The LSB data written to the selected channel's DAC control register is shown in the register display at the top right of Figure 12.

Table 9. DAC Control Register Functions

Option	Description
EN Internal	Powers up internal amplifiers. This should be done when enabling the output.
EN Clear	Selects if the channel clears when the CLEAR pin is activated.
EN Output Rset	Enables/disables the selected output channel. Selects whether internal or external sense resistor is used when using a current range.
EN DC-DC	Powers up/down the dc-to-dc converter on a selected channel. To correctly power down the dc-to-dc converter, EN Output and EN Internal must also be disabled.
Over-Range	Enables/disables 20% overrange. This is available on V <sub>OUT</sub> ranges only.
Output Range	Selects the output range for the specified channel.

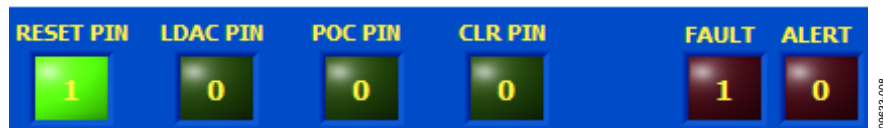

Figure 9. Digital Pin Controls and Indicators in the Evaluation Software



Figure 10. Write to Data Register in the Evaluation Software



Figure 11. Read from Register in the Evaluation Software



Figure 12. Write to the DAC Control Registers in the Evaluation Software

**WRITING TO THE DC-TO-DC CONTROL REGISTER**

This function allows you to write to and configure the dc-to-dc control register. Select the required clamp voltage, switching frequency, and phase from the pull-down menu and click **WRITE** to write the selected data to the device. On the evaluation board, the dc-to-dc converter perform best at a 410 kHz switching frequency (see the DC-to-DC Boost section). See the appropriate data sheet for information on the DC-DC Comp bit. If selecting an external compensation resistor, this can be placed at R12, R13, R14, and R15.

**WRITING TO THE MAIN CONTROL REGISTER**

This function allows you to write to and configure the main control register. After configuring the settings you require, click **WRITE** to write to the device.

**WRITING TO THE SLEW RATE CONTROL REGISTER**

The slew rate control register can be accessed from the tab at the bottom of the evaluation software window (see Figure 15). The slew rate control functions (**Slew Rate Clock** and **Slew Rate Step**) allow you to configure the slew rate on a per-channel basis. After configuring the setting you require, click **WRITE** to write to the device.

Table 10. Slew Rate Register Functions

Option	Description
SE	Enable/disable the slew rate control feature.
Slew Rate Clock	Set the slew clock rate.
Slew Rate Step	Set the step size when slewing.



Figure 13. Write to the DC-to-DC Control Register in the Evaluation Software



Figure 14. Write to the Main Control Register in the Evaluation Software

Table 11. Main Control Register Functions

Option	Description
POC	Determines the state of the V <sub>OUT</sub> channel when the voltage output channel is disabled during normal operation. Disabled: disabled V <sub>OUT</sub> channels goes to the function set by the POC pin. Enabled: disabled V <sub>OUT</sub> channels goes to the opposite function of the POC pin.
STATREAD	Enable/disable status readback during a write (see the Status Readback section for details about using this feature).
EWD	Enable/disable the watchdog timer (see the Writing to the Main Control Register section for details about using this feature).
Watchdog Timeout	Select timeout period for watchdog timer (using 100 ms or 200 ms with the evaluation software recommended).
ShtCctLim	Selects short-circuit current limit on the V <sub>OUT</sub> channels.
OUTEN ALL	Enables the output on all four DACs simultaneously. Do not use <b>OUTEN ALL</b> when enabling channels via the DAC control registers.
DC-DC ALL	When set, powers up the dc-to-dc converter on all four channels simultaneously. To power down the dc-to-dc converters, all channels outputs must first be disabled. Do not use the <b>DC-DC ALL</b> option when enabling the dc-to-dc converters via the DAC control registers.

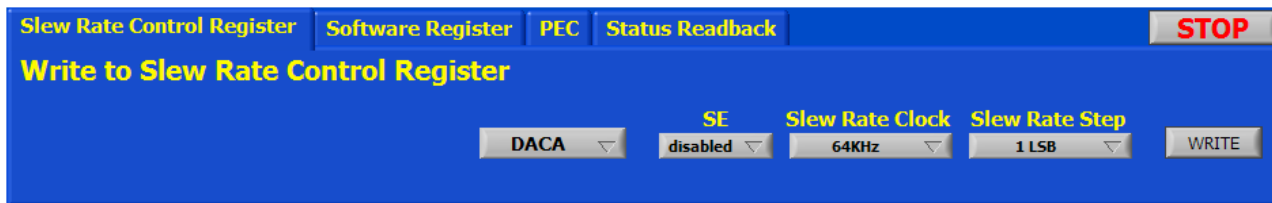

Figure 15. Write to the Slew Rate Control Register and Other Functions in the Evaluation Software

## SOFTWARE REGISTER

Click the **Software Register** tab shown in Figure 15 to access this feature. From this tab, you can set the user toggle bit that is contained in the status register and perform a software reset.

This tab contains a feature for using the watchdog timer. By entering a value for **Delay (ms)**, the evaluation software attempts to send the SPI code required to the software register (0x195) in approximately the time specified. Note that, because the latency of the USB connection is not strictly defined, this time delay is only a rough estimate but can be far exceeded. It is recommended to use the 100 ms or 200 ms watchdog timeouts when using this feature.

This tab also contains the option to latch the ALERT pin display in the evaluation software. See the Control of Digital Pins section for more information on the ALERT pin.

## PEC

Click the **PEC** tab shown in Figure 15 to access this feature. Click the **Use PEC** button to enable the automatic PEC feature of the device: an 8-bit PEC code is appended to the end of every write sequence and is read at the end of every read sequence. The data and PEC written are displayed in this tab; if a PEC error occurs, the  $\overline{\text{FAULT}}$  pin lights up. During a read operation, the data received from the device and the PEC code received are displayed in this tab.

## STATUS READBACK

When **STATREAD** is enabled (see Figure 14), the status register is displayed in the **Status Readback** tab shown in Figure 15. Note that the status register readback on a write operation reports any errors present immediately before the current write command.



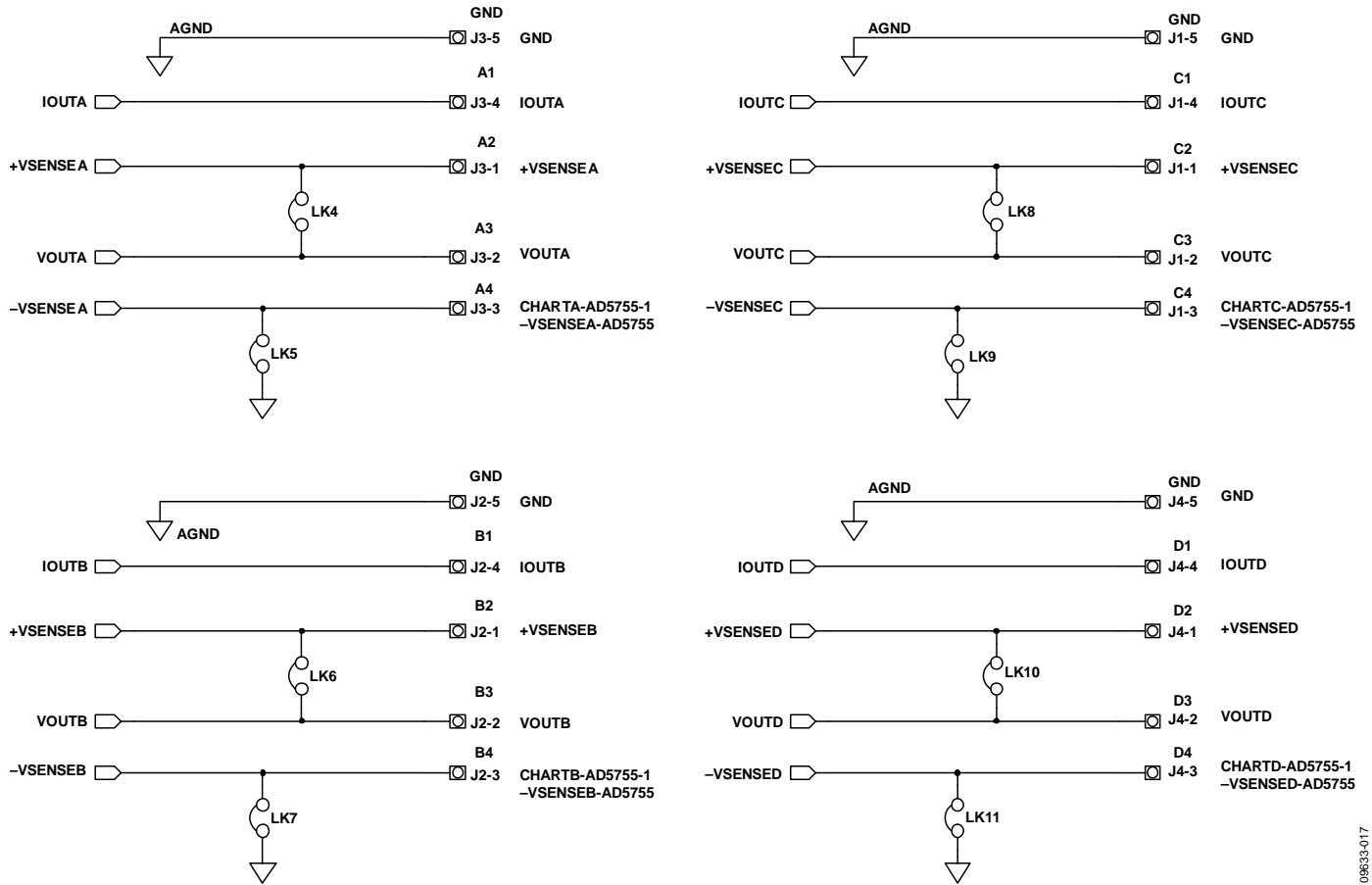

Figure 18. Output (Terminal Blocks) Circuitry

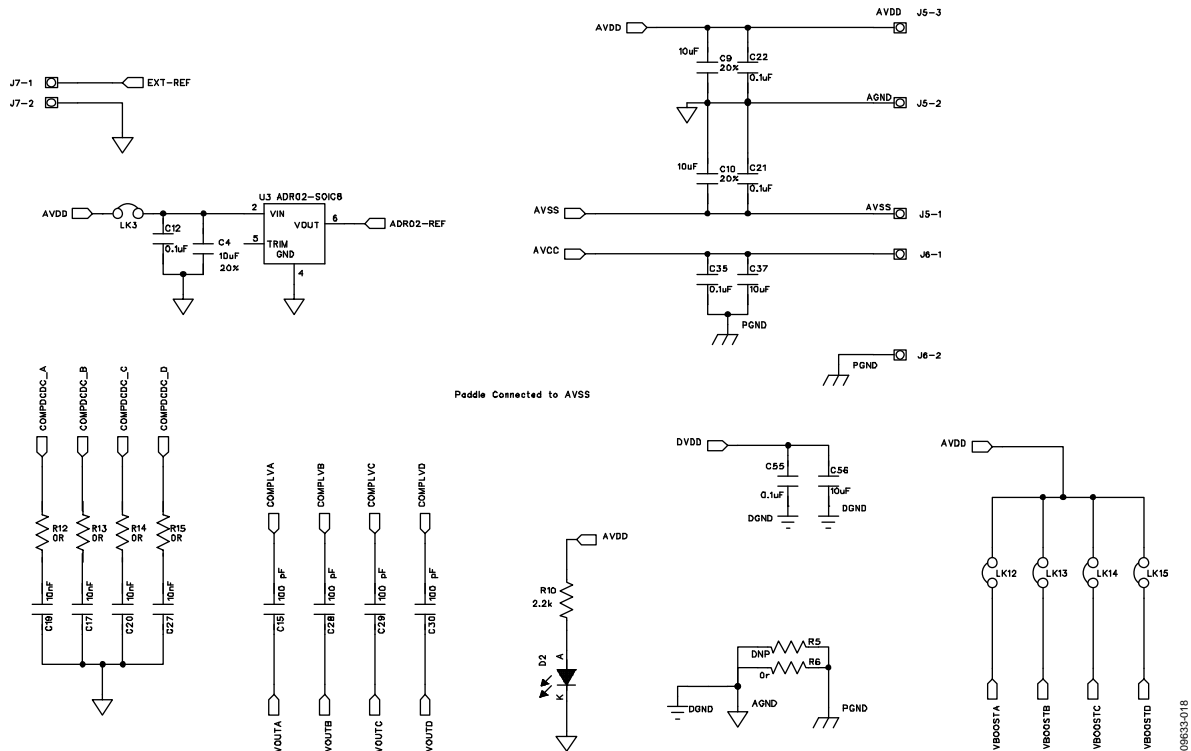

Figure 19. Supply Connections and Circuitry

09633-017

09633-018

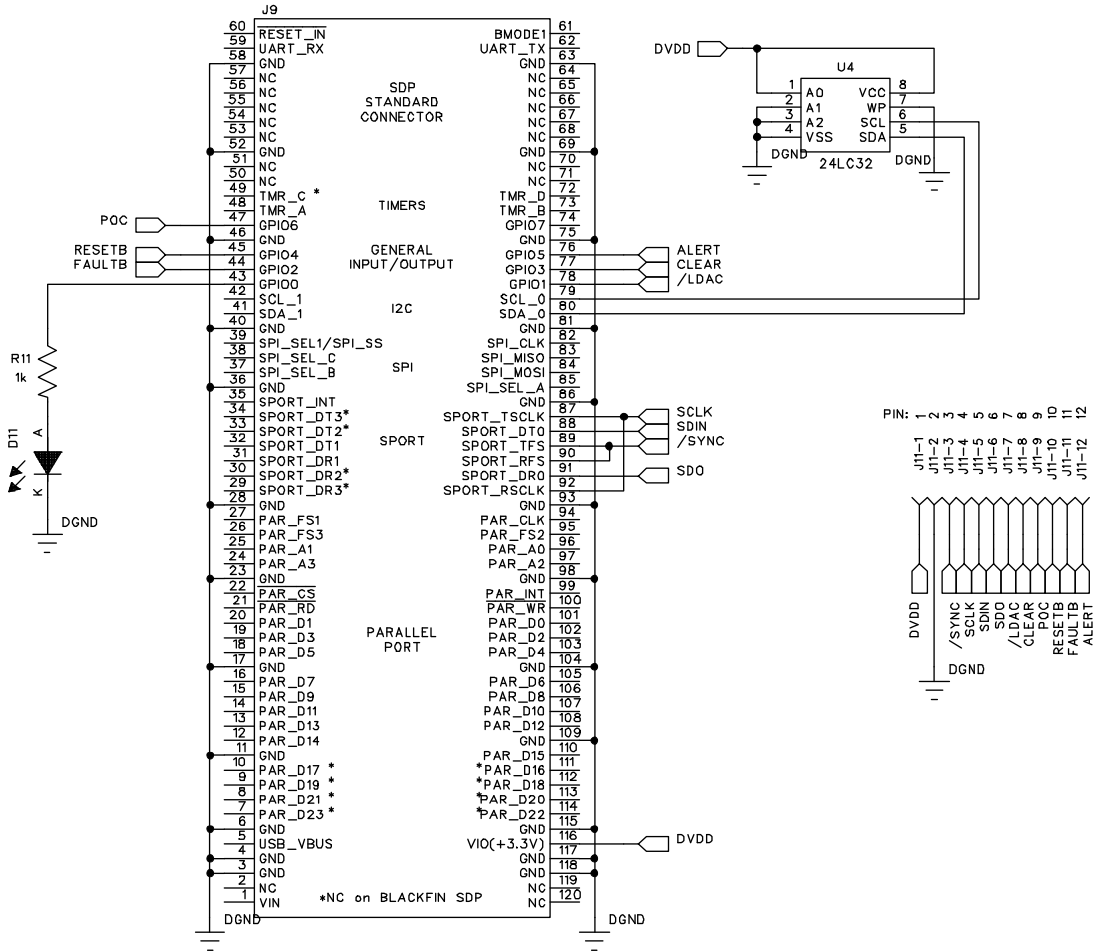

Figure 20. SDP Board Connector

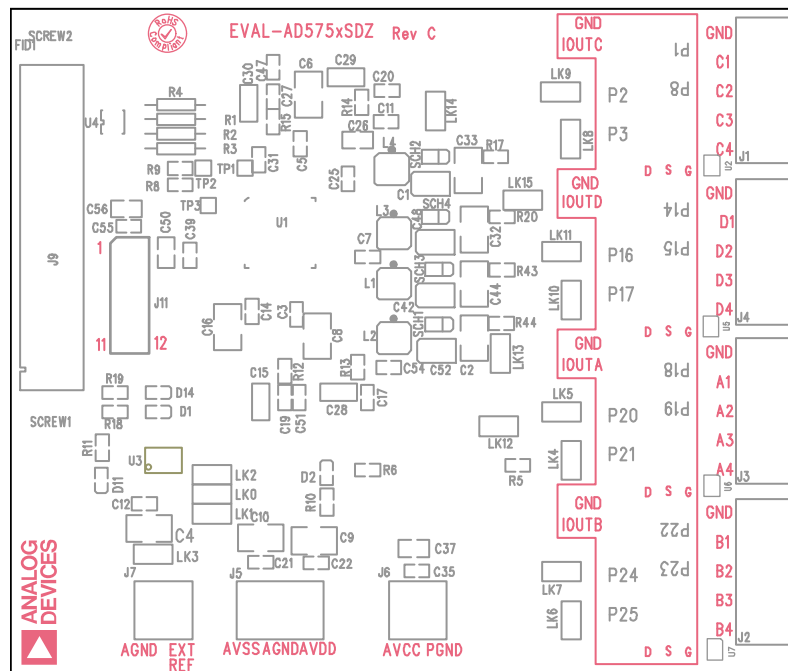
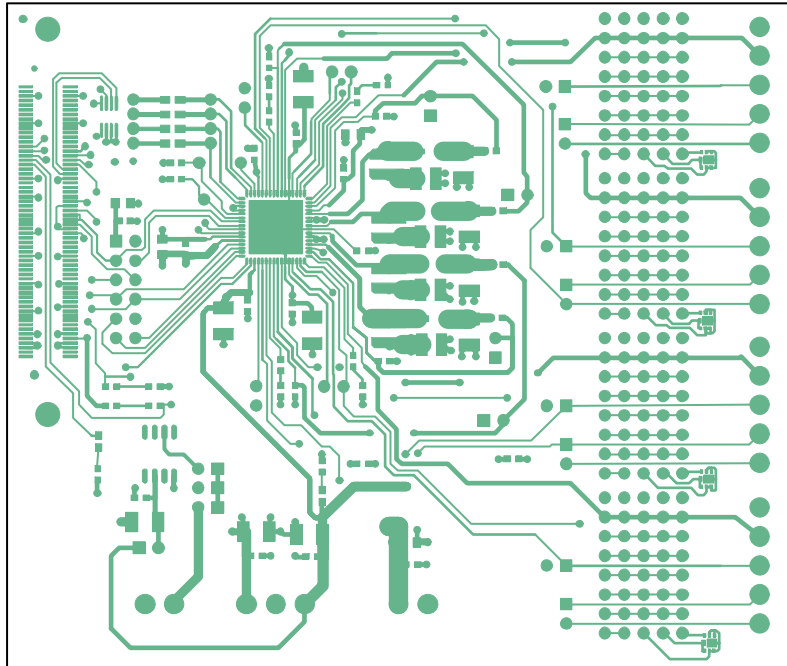
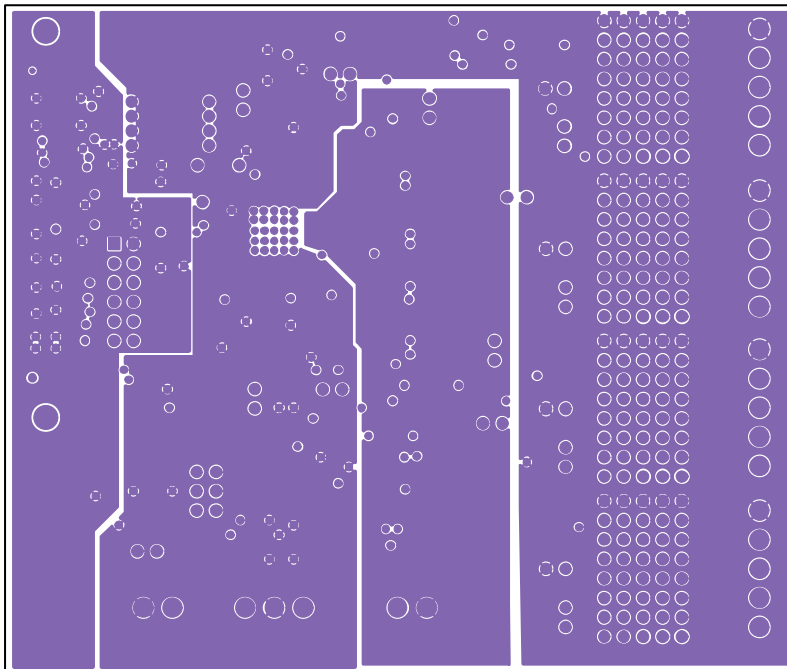

Figure 21. Component Placement



06R33-021

Figure 22. Top PCB Layer



06R33-022

Figure 23. Inner First PCB Layer

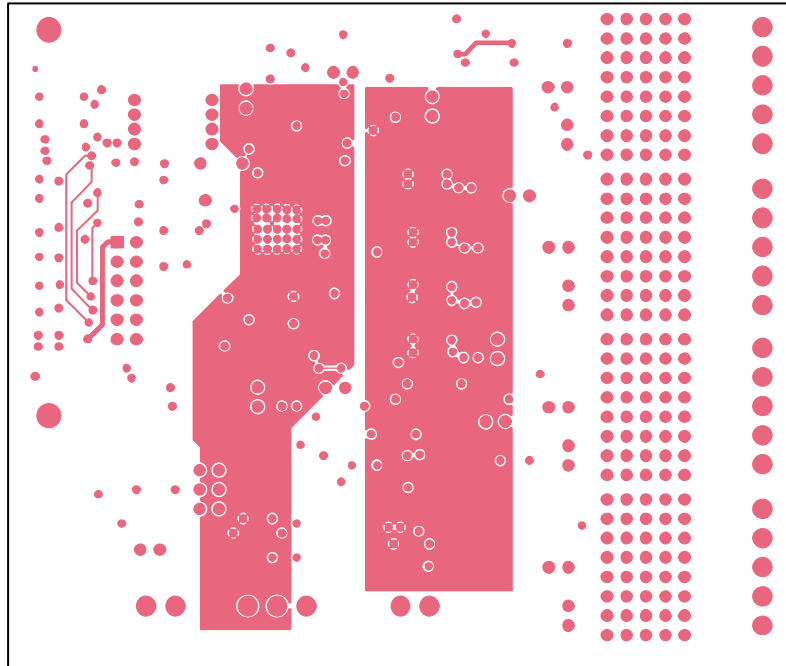

09833-023

Figure 24. Inner Second PCB Layer

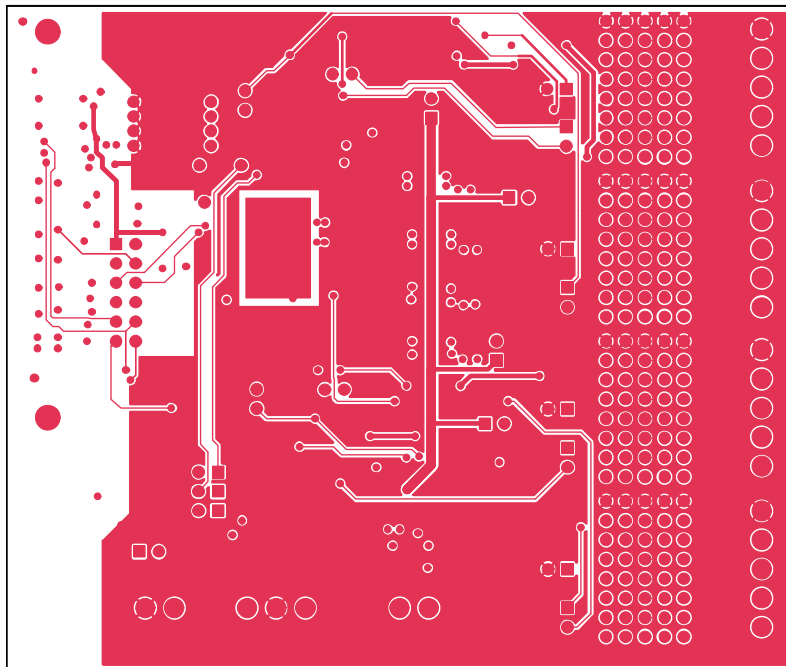

09833-024

Figure 25. Bottom PCB Layer

## ORDERING INFORMATION

### BILL OF MATERIALS

Table 12.

Qty	Reference Designator	Part Description	Part Number	Stock Code
4	C1, C42, C48, C52	10 $\mu$ F, 10 V, SMD tantalum capacitor, Case A	TCJA106M010R0300	FEC 1135234
4	C2, C32, C33, C44	4.7 $\mu$ F, 50 V, X7R ceramic capacitor, 1210	GRM32ER71H475KA88L	FEC 1404215
5	C4, C6, C8, C10, C16	10 $\mu$ F, 50 V, X5R ceramic capacitor, 1210	UMK325BJ106MM-T	FEC 1683595
17	C3, C5, C7, C9, C11, C12, C14, C21, C22, C25, C31, C35, C39, C47, C51, C54, C55	0.1 $\mu$ F, 50 V, X7R ceramic capacitor, 0603	C0603C104K5RAC	FEC 1288255
4	C15, C28 to C30	100 pF, 100 V, COG ceramic capacitor, radial	B37979G1101J	FEC 1200381
4	C17, C19, C20, C27	10 nF, 50 V, X7R ceramic capacitor, 0603	B37931K5103K60	FEC 753622
4	C26, C37, C50, C56	10 $\mu$ F, 16 V, X5R ceramic capacitor, 0805	GRM21BR61C106KE15L	FEC 1762635
1	D1	Red, SMD LED, 0603	SML-D12U8WT86	FEC 1685094
3	D2, D11, D14	Green, SMD LED, 0603	SML-512MWT86R	FEC 1685076
4	J1 to J4	5-pin terminal block (3.81 mm pitch)	3704609	FEC 3704609
1	J5	3-pin terminal block (3.81 mm pitch)	1727023	FEC 3704580
2	J6, J7	2-pin terminal block (3.81 mm pitch)	1727010	FEC 3704579
1	J9	120-way connector, 0.6 mm pitch	FX8-120S-SV(21)	FEC 1324660
1	J11	12-pin (2 $\times$ 6) 0.1" pitch header	M20-9980646	FEC 1022238
4	L1 to L4	Inductor	XAL4040-103	Coilcraft XAL4040-103
16	LK0 to L15	2-pin (0.1" pitch) header and jumper socket	M20-9990246	FEC 1022247 and FEC 150411
4	R1, R2, R3, R4	15 k $\Omega$ , low drift, SMD resistor, 0805	PCF0805-13-15K-B-T1	FEC 1108896
1	R5	0 $\Omega$ , SMD resistor, 0603	CRCW06030000Z0EA	DNP
7	R6, R8, R9, R12, R13, R14, R15	0 $\Omega$ , SMD resistor, 0603	CRCW06030000Z0EA	FEC 1469739
1	R10	2.2 k $\Omega$ , SMD resistor, 0603	CRCW06032K20JNEA	FEC 1652868
3	R11, R18, R19	1 k $\Omega$ , SMD resistor, 0603	CRCW06031K00JNEA	FEC 1652851
4	R17, R20, R43, R44	10 $\Omega$ , SMD resistor, 0603	CRCW060310R0FKEA	FEC 1469751
4	SCH1 to SCH4	1 A, 30 V, Schottky diode, SOD323	PMEG3010BEA	FEC 8737991
3	TP1 to TP3	Test point		DNP
1	U1	Quad 16-bit DAC with dynamic power control	AD5755-1	AD5755-1ACPZ
1	U3	5 V precision reference, 8-lead SOIC	ADR02BRZ	ADR02BRZ
1	U4	32 kB $\mu$ C serial EEPROM, 8-lead MSOP	24LC32A-I/MS	FEC 1331330
4	U2, U5, U6, U7	MOSFET P-channel, 30 V. Only populate on EVAL-AD5757 boards	NTLJS4149PTAG	N/A

### RELATED LINKS

Resource	Description
<a href="#">AD5755</a>	Product Page, Quad Channel, 16-Bit, Serial Input, 4 mA to 20 mA and Voltage Output DAC, Dynamic Power Control
<a href="#">AD5757</a>	Product Page, Quad Channel, 16-Bit, Serial Input, 4 mA to 20 mA Output DAC, Dynamic Power Control, HART Connectivity
<a href="#">AD5755-1</a>	Product Page, Quad Channel, 16-Bit, Serial Input, 4 mA to 20 mA and Voltage Output DAC, Dynamic Power Control, HART Connectivity
<a href="#">ADR02</a>	Product Page, Ultracompact, Precision 5.0 V Voltage Reference

## NOTES

**ESD Caution**

**ESD (electrostatic discharge) sensitive device.** Charged devices and circuit boards can discharge without detection. Although this product features patented or proprietary protection circuitry, damage may occur on devices subjected to high energy ESD. Therefore, proper ESD precautions should be taken to avoid performance degradation or loss of functionality.

**Legal Terms and Conditions**

By using the evaluation board discussed herein (together with any tools, components documentation or support materials, the "Evaluation Board"), you are agreeing to be bound by the terms and conditions set forth below ("Agreement") unless you have purchased the Evaluation Board, in which case the Analog Devices Standard Terms and Conditions of Sale shall govern. Do not use the Evaluation Board until you have read and agreed to the Agreement. Your use of the Evaluation Board shall signify your acceptance of the Agreement. This Agreement is made by and between you ("Customer") and Analog Devices, Inc. ("ADI"), with its principal place of business at One Technology Way, Norwood, MA 02062, USA. Subject to the terms and conditions of the Agreement, ADI hereby grants to Customer a free, limited, personal, temporary, non-exclusive, non-sublicensable, non-transferable license to use the Evaluation Board FOR EVALUATION PURPOSES ONLY. Customer understands and agrees that the Evaluation Board is provided for the sole and exclusive purpose referenced above, and agrees not to use the Evaluation Board for any other purpose. Furthermore, the license granted is expressly made subject to the following additional limitations: Customer shall not (i) rent, lease, display, sell, transfer, assign, sublicense, or distribute the Evaluation Board; and (ii) permit any Third Party to access the Evaluation Board. As used herein, the term "Third Party" includes any entity other than ADI, Customer, their employees, affiliates and in-house consultants. The Evaluation Board is NOT sold to Customer; all rights not expressly granted herein, including ownership of the Evaluation Board, are reserved by ADI. CONFIDENTIALITY. This Agreement and the Evaluation Board shall all be considered the confidential and proprietary information of ADI. Customer may not disclose or transfer any portion of the Evaluation Board to any other party for any reason. Upon discontinuation of use of the Evaluation Board or termination of this Agreement, Customer agrees to promptly return the Evaluation Board to ADI. ADDITIONAL RESTRICTIONS. Customer may not disassemble, decompile or reverse engineer chips on the Evaluation Board. Customer shall inform ADI of any occurred damages or any modifications or alterations it makes to the Evaluation Board, including but not limited to soldering or any other activity that affects the material content of the Evaluation Board. Modifications to the Evaluation Board must comply with applicable law, including but not limited to the RoHS Directive. TERMINATION. ADI may terminate this Agreement at any time upon giving written notice to Customer. Customer agrees to return to ADI the Evaluation Board at that time. LIMITATION OF LIABILITY. THE EVALUATION BOARD PROVIDED HEREUNDER IS PROVIDED "AS IS" AND ADI MAKES NO WARRANTIES OR REPRESENTATIONS OF ANY KIND WITH RESPECT TO IT. ADI SPECIFICALLY DISCLAIMS ANY REPRESENTATIONS, ENDORSEMENTS, GUARANTEES, OR WARRANTIES, EXPRESS OR IMPLIED, RELATED TO THE EVALUATION BOARD INCLUDING, BUT NOT LIMITED TO, THE IMPLIED WARRANTY OF MERCHANTABILITY, TITLE, FITNESS FOR A PARTICULAR PURPOSE OR NON-INFRINGEMENT OF INTELLECTUAL PROPERTY RIGHTS. IN NO EVENT WILL ADI AND ITS LICENSORS BE LIABLE FOR ANY INCIDENTAL, SPECIAL, INDIRECT, OR CONSEQUENTIAL DAMAGES RESULTING FROM CUSTOMER'S POSSESSION OR USE OF THE EVALUATION BOARD, INCLUDING BUT NOT LIMITED TO LOST PROFITS, DELAY COSTS, LABOR COSTS OR LOSS OF GOODWILL. ADI'S TOTAL LIABILITY FROM ANY AND ALL CAUSES SHALL BE LIMITED TO THE AMOUNT OF ONE HUNDRED US DOLLARS (\$100.00). EXPORT. Customer agrees that it will not directly or indirectly export the Evaluation Board to another country, and that it will comply with all applicable United States federal laws and regulations relating to exports. GOVERNING LAW. This Agreement shall be governed by and construed in accordance with the substantive laws of the Commonwealth of Massachusetts (excluding conflict of law rules). Any legal action regarding this Agreement will be heard in the state or federal courts having jurisdiction in Suffolk County, Massachusetts, and Customer hereby submits to the personal jurisdiction and venue of such courts. The United Nations Convention on Contracts for the International Sale of Goods shall not apply to this Agreement and is expressly disclaimed.