

FEATURES

- Powered from 2.7 V to 5.5 V on the VCC pin
- Monitors 4 supplies via 0.8% accurate comparators
- 4 inputs can be programmed to monitor different voltage levels with external resistor dividers
- 3 open-drain enable outputs (OUT1, OUT2, and OUT3)
- Open-drain power-good output (PWRGD)
- Internal 190 ms delay associated with assertion of PWRGD
- 10-lead MSOP

APPLICATIONS

- Monitor and alarm functions
- Telecommunications
- Microprocessor systems
- PC/servers

GENERAL DESCRIPTION

The ADM1184 is an integrated, 4-channel voltage-monitoring device. A 2.7 V to 5.5 V power supply is required on the VCC pin to power the device.

Four precision comparators monitor four voltage rails. Each comparator has a 0.6 V reference with a worst-case accuracy of 0.8%. Resistor networks that are external to the VIN1, VIN2, VIN3, and VIN4 pins set the trip points for the monitored supply rails.

The ADM1184 has four open-drain outputs. OUT1 to OUT3 can be used to enable power supplies, and PWRGD is a common power-good output.

FUNCTIONAL BLOCK DIAGRAM

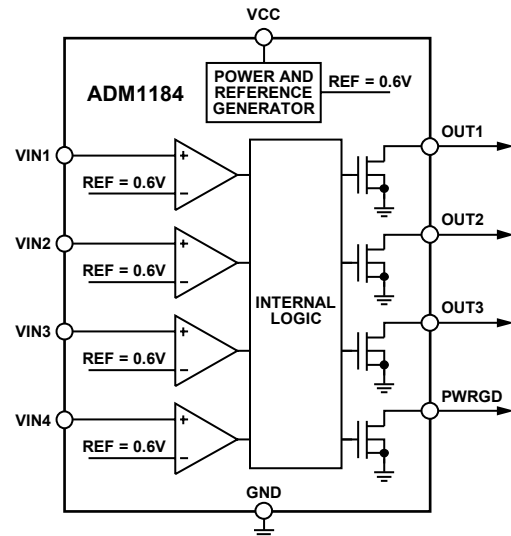

Figure 1.

07352-001

OUT1 to OUT3 are dependent on their associated VIN_x input (that is, VIN1, VIN2, or VIN3). If a supply monitored by VIN_x drops below its programmed threshold, the associated OUT_x pin and PWRGD are disabled.

PWRGD is a common power-good output indicating the status of all monitored supplies. There is an internal 190 ms (typical) delay associated with the assertion of the PWRGD output. If VIN1, VIN2, VIN3, or VIN4 drops below its programmed threshold, PWRGD is deasserted immediately.

The ADM1184 is available in a 10-lead mini small outline package (MSOP).

Rev. 0

Information furnished by Analog Devices is believed to be accurate and reliable. However, no responsibility is assumed by Analog Devices for its use, nor for any infringements of patents or other rights of third parties that may result from its use. Specifications subject to change without notice. No license is granted by implication or otherwise under any patent or patent rights of Analog Devices. Trademarks and registered trademarks are the property of their respective owners.

ADM1184* Product Page Quick Links

Last Content Update: 08/30/2016

[Comparable Parts](#)

View a parametric search of comparable parts

[Evaluation Kits](#)

- [ADM1184 Evaluation Board](#)

[Documentation](#)

Application Notes

- [AN-1311: Complex Power Supply Sequencing Made Easy](#)

Data Sheet

- [ADM1184: 0.8% Accurate Quad Voltage Monitor Data Sheet](#)

[Reference Materials](#)

Product Selection Guide

- [Supervisory Devices Complementary Parts Guide for Altera FPGAs](#)
- [Supervisory Devices Complementary Parts Guide for Xilinx FPGAs](#)

[Design Resources](#)

- [ADM1184 Material Declaration](#)
- [PCN-PDN Information](#)
- [Quality And Reliability](#)
- [Symbols and Footprints](#)

[Discussions](#)

View all ADM1184 EngineerZone Discussions

[Sample and Buy](#)

Visit the product page to see pricing options

[Technical Support](#)

Submit a technical question or find your regional support number

* This page was dynamically generated by Analog Devices, Inc. and inserted into this data sheet. Note: Dynamic changes to the content on this page does not constitute a change to the revision number of the product data sheet. This content may be frequently modified.

TABLE OF CONTENTS

Features	1	Pin Configuration and Function Descriptions.....	5
Applications.....	1	Typical Performance Characteristics	6
Functional Block Diagram	1	Theory of Operation	9
General Description	1	Input Configuration.....	9
Revision History	2	Output Configuration.....	9
Specifications.....	3	Voltage Monitoring and Sequencing Application.....	11
Absolute Maximum Ratings.....	4	Outline Dimensions	12
Thermal Resistance	4	Ordering Guide	12
ESD Caution.....	4		

REVISION HISTORY

2/08—Revision 0: Initial Version

SPECIFICATIONS

$V_{CC} = 2.7\text{ V to }5.5\text{ V}$, $T_A = -40^\circ\text{C to }+85^\circ\text{C}$.

Table 1.

Parameter	Min	Typ	Max	Unit	Conditions
VCC Pin					
Operating Voltage Range, V_{CC}	2.7	3.3	5.5	V	
Supply Current, I_{VCC}		24	80	μA	
VIN1 to VIN4 (VINx) Pins					
Input Current, $I_{VINLEAK}$	-20		+20	nA	$V_{VINx} = 0.7\text{ V}$
Input Threshold, V_{TH}	0.5952	0.6000	0.6048	V	
OUT1 to OUT3 (OUTx), PWRGD Pins					
Output Low Voltage, V_{OUTL}			0.4	V	$V_{CC} = 2.7\text{ V}$, $I_{SINK} = 2\text{ mA}$
Leakage Current, I_{ALERT}	-1		+1	μA	$V_{CC} = 1\text{ V}$, $I_{SINK} = 100\text{ }\mu\text{A}$
V_{CC} that Guarantees Valid Outputs	1			V	All outputs are guaranteed to be either low or to give a valid output level from $V_{CC} = 1\text{ V}$
TIMING DELAYS					Refer to the timing diagrams in Figure 18 and Figure 19
VIN1 to OUT1, VIN2 to OUT2, VIN3 to OUT3					
Low-to-High Propagation Delay		30		μs	$V_{CC} = 3.3\text{ V}$
High-to-Low Propagation Delay, All Inputs		30		μs	$V_{CC} = 3.3\text{ V}$
All Inputs High to PWRGD Rising Delay	100	190	280	ms	$V_{CC} = 3.3\text{ V}$

ABSOLUTE MAXIMUM RATINGS

$T_A = 25^\circ\text{C}$, unless otherwise noted.

Table 2.

Parameter	Rating
VCC Pin	-0.3 V to +6 V
VINx Pins	-0.3 V to +6 V
OUTx, PWRGD Pins	-0.3 V to +6 V
Storage Temperature Range	-65°C to +125°C
Operating Temperature Range	-40°C to +85°C
Lead Temperature Soldering (10 sec)	300°C
Junction Temperature	150°C

Stresses above those listed under Absolute Maximum Ratings may cause permanent damage to the device. This is a stress rating only; functional operation of the device at these or any other conditions above those indicated in the operational section of this specification is not implied. Exposure to absolute maximum rating conditions for extended periods may affect device reliability.

THERMAL RESISTANCE

θ_{JA} is specified for the worst-case conditions, that is, a device soldered in a circuit board for surface-mount packages.

Table 3. Thermal Resistance

Package Type	θ_{JA}	Unit
10-Lead MSOP	137.5	$^\circ\text{C}/\text{W}$

ESD CAUTION



ESD (electrostatic discharge) sensitive device. Charged devices and circuit boards can discharge without detection. Although this product features patented or proprietary protection circuitry, damage may occur on devices subjected to high energy ESD. Therefore, proper ESD precautions should be taken to avoid performance degradation or loss of functionality.

PIN CONFIGURATION AND FUNCTION DESCRIPTIONS

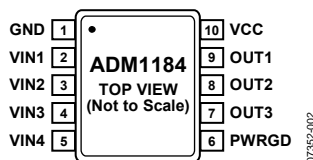

Figure 2. Pin Configuration

Table 4. Pin Function Descriptions

Pin No.	Mnemonic	Description
1	GND	Chip Ground Pin.
2	VIN1	Noninverting Input of Comparator 1. The voltage on this pin is compared with a 0.6 V reference. Can be used to monitor a voltage rail via a resistor divider.
3	VIN2	Noninverting Input of Comparator 2. The voltage on this pin is compared with a 0.6 V reference. Can be used to monitor a voltage rail via a resistor divider.
4	VIN3	Noninverting Input of Comparator 3. The voltage on this pin is compared with a 0.6 V reference. Can be used to monitor a voltage rail via a resistor divider.
5	VIN4	Noninverting Input of Comparator 4. The voltage on this pin is compared with a 0.6 V reference. Can be used to monitor a voltage rail via a resistor divider.
6	PWRGD	Active High, Open-Drain Output. When the voltage on each VINx input exceeds 0.6 V, PWRGD is asserted after a 190 ms delay. Once PWRGD has been asserted, if the voltage monitored by VIN1, VIN2, VIN3, or VIN4 falls below 0.6 V, the PWRGD output is deasserted immediately.
7	OUT3	Active High, Open-Drain Output. When the voltage on VIN3 exceeds 0.6 V, OUT3 is asserted. OUT3 remains asserted until the voltage monitored by VIN3 falls below 0.6 V, and then it is driven low.
8	OUT2	Active High, Open-Drain Output. When the voltage on VIN2 exceeds 0.6 V, OUT2 is asserted. OUT2 remains asserted until the voltage monitored by VIN2 falls below 0.6 V, and then it is driven low.
9	OUT1	Active High, Open-Drain Output. When the voltage on VIN1 exceeds 0.6 V, OUT1 is asserted. OUT1 remains asserted until the voltage monitored by VIN1 falls below 0.6 V, and then it is driven low.
10	VCC	Positive Supply Input Pin. The operating supply voltage range is 2.7 V to 5.5 V.

TYPICAL PERFORMANCE CHARACTERISTICS

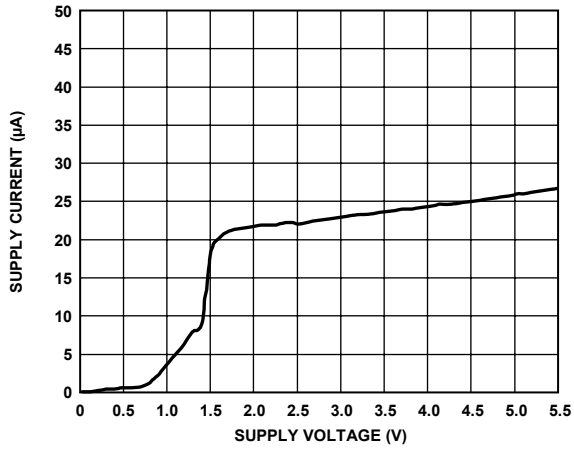

Figure 3. Supply Current vs. Supply Voltage

07352-003

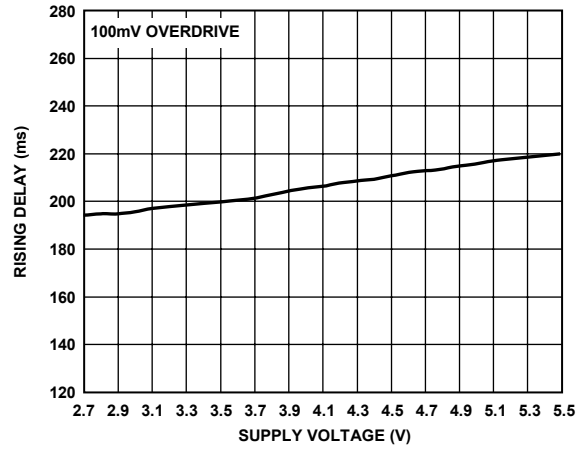

Figure 6. All Inputs High to PWRGD Rising Delay vs. Supply Voltage

07352-006

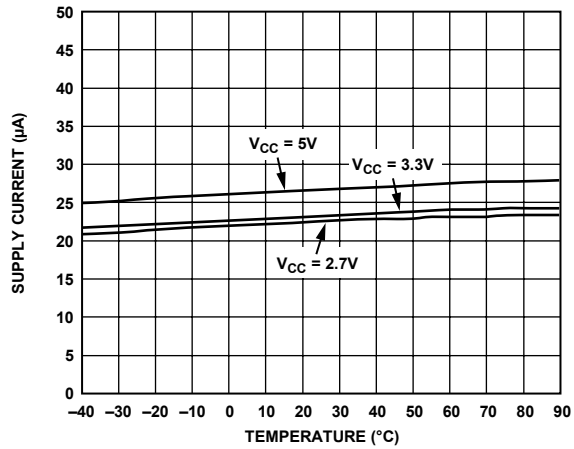

Figure 4. Supply Current vs. Temperature

07352-004

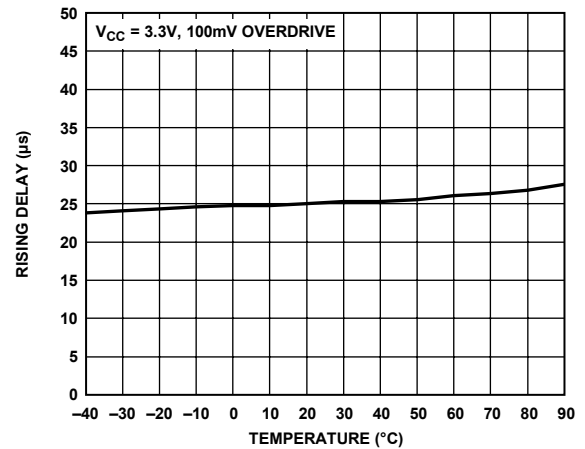

Figure 7. VIN1/VIN2/VIN3 to OUT1/OUT2/OUT3 Rising Delay vs. Temperature

07352-007

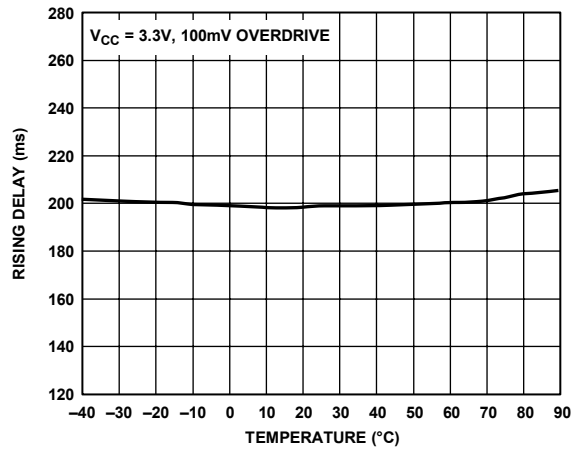

Figure 5. All Inputs High to PWRGD Rising Delay vs. Temperature

07352-005

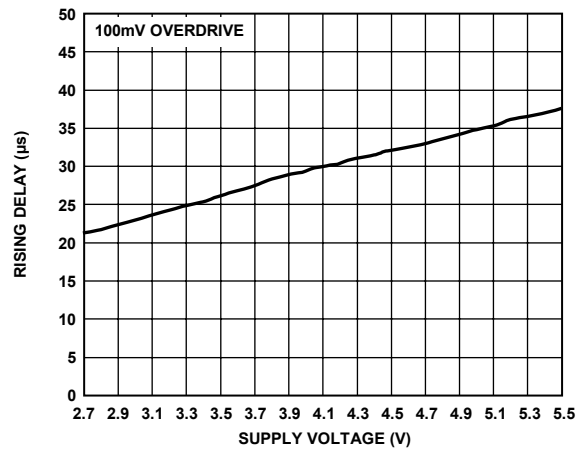

Figure 8. VIN1/VIN2/VIN3 to OUT1/OUT2/OUT3 Rising Delay vs. Supply Voltage

07352-008

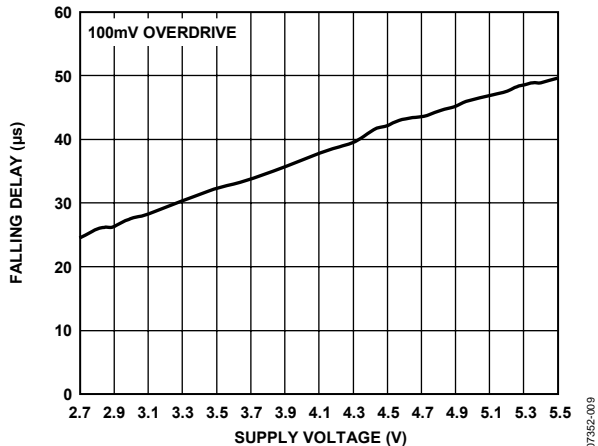

Figure 9. VINx to Output Falling Delay vs. Supply Voltage

07352-09

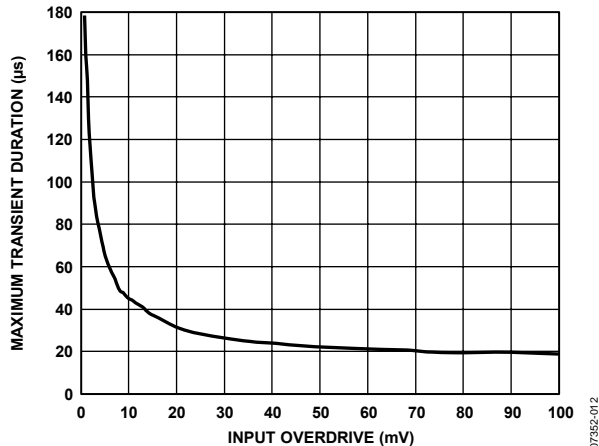

Figure 12. Trip Threshold Maximum Transient Duration vs. Input Overdrive

07352-012

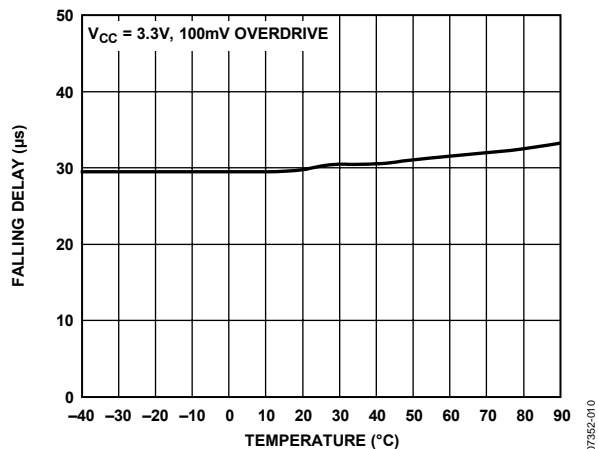

Figure 10. VINx to Output Falling Delay vs. Temperature

07352-010

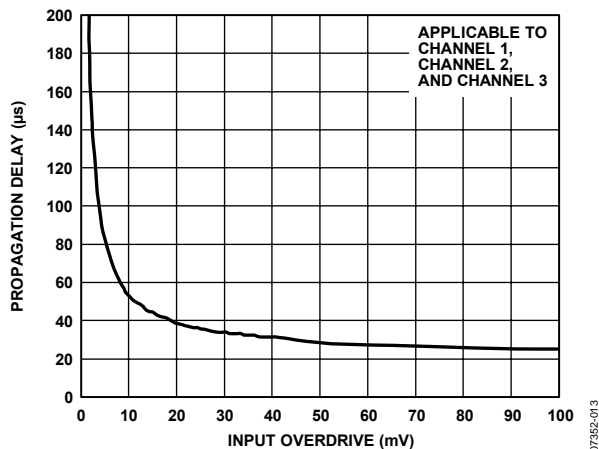

Figure 13. Propagation Delay vs. Input Overdrive

07352-013

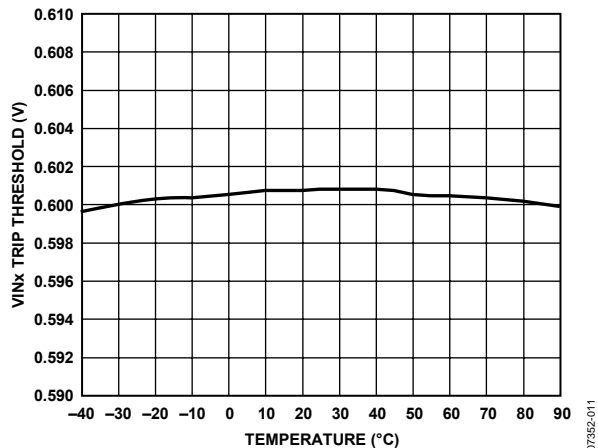

Figure 11. VINx Trip Threshold vs. Temperature

07352-011

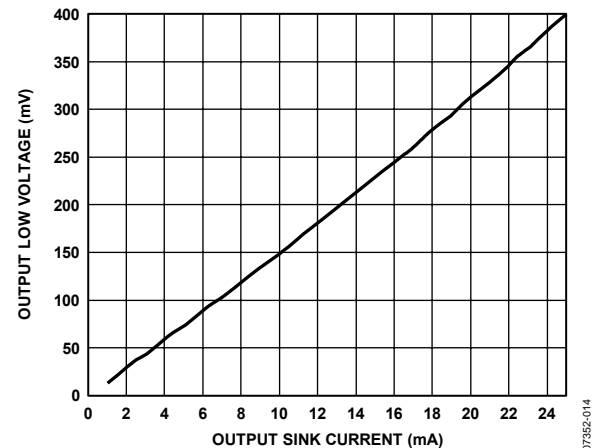

Figure 14. Output Low Voltage vs. Output Sink Current

07352-014

ADM1184

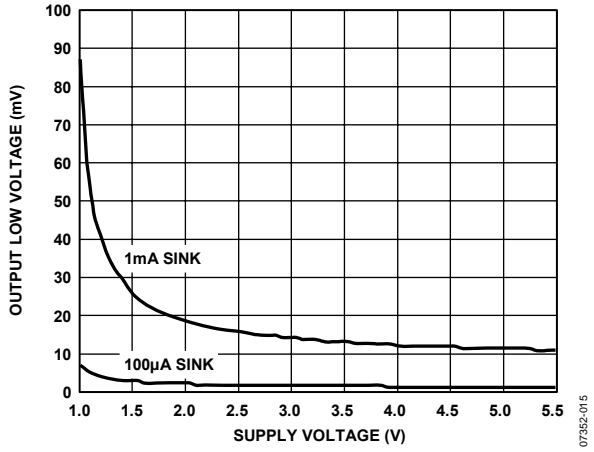

Figure 15. Output Low Voltage vs. Supply Voltage

07352-015

THEORY OF OPERATION

The ADM1184 is an integrated, 4-channel voltage-monitoring device. A 2.7 V to 5.5 V power supply is required on the VCC pin to power the device.

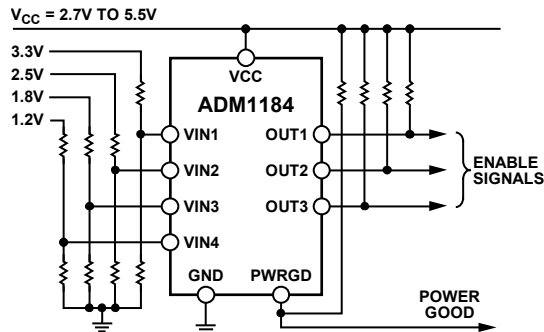

Figure 16. Typical Applications Circuit

INPUT CONFIGURATION

Four precision comparators monitor four voltage rails. Each comparator has a 0.6 V reference with a worst-case accuracy of 0.8%. Resistor networks external to the VIN1, VIN2, VIN3, and VIN4 pins set the trip points for the monitored supply rails.

Typically, the threshold voltage at each of the four adjustable inputs (that is, VIN1, VIN2, VIN3, and VIN4) is 0.6 V. To monitor a voltage greater than 0.6 V, connect a resistor divider network to the circuit as depicted in Figure 17.

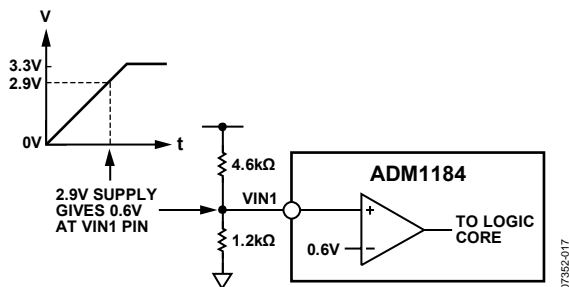

Figure 17. Setting the Undervoltage Threshold

In this example, the VIN1 pin monitors a 3.3 V supply. An external resistor divider scales this voltage down for monitoring at the VIN1 pin. The resistor ratio is chosen so that the VIN1 voltage is 0.6 V when the main voltage rises to the preferred level at startup (a voltage below the nominal 3.3 V level). R1 is 4.6 kΩ and R2 is 1.2 kΩ; therefore, a voltage level of 2.9 V corresponds to 0.6 V on the noninverting input of the first comparator (see Figure 17).

OUTPUT CONFIGURATION

The ADM1184 has four open-drain, active high outputs. Of these outputs, OUT1 to OUT3 can be used to enable power supplies, and PWRGD is a common power-good output.

Output OUT1 to Output OUT3 are dependent on their associated input (that is, VIN1, VIN2, or VIN3). Before the voltage on a VINx input reaches 0.6 V, the corresponding output is switched to ground if there is 1 V on the VCC pin of the ADM1184. When VINx detects 0.6 V, OUTx is asserted after a 30 μs (typical) delay.

When all four monitored supplies exceed 0.6 V, a system power-good signal (PWRGD) is asserted. There is an internal 190 ms (typical) delay associated with the assertion of the PWRGD output. After PWRGD is asserted, if any of the four monitored supplies drops below its programmed threshold, the corresponding OUTx output and the PWRGD output are deasserted. If only the supply monitored by VIN4 drops below its programmed threshold, just the PWRGD output is deasserted.

The ADM1184 functional truth table is shown in Table 5. Note that the functional operation described in Table 5 applies to the operation both before and after the assertion of PWRGD.

Table 5. Functional Truth Table

VIN1	VIN2	VIN3	VIN4	OUT1	OUT2	OUT3	PWRGD
0 ¹	0	0	0	Low	Low	Low	Low
0	0	0	1 ²	Low	Low	Low	Low
0	0	1	0	Low	Low	High	Low
0	0	1	1	Low	Low	High	Low
0	1	0	0	Low	High	Low	Low
0	1	0	1	Low	High	Low	Low
0	1	1	0	Low	High	High	Low
0	1	1	1	Low	High	High	Low
1	0	0	0	High	Low	Low	Low
1	0	0	1	High	Low	Low	Low
1	0	1	0	High	Low	High	Low
1	0	1	1	High	Low	High	Low
1	1	0	0	High	High	Low	Low
1	1	0	1	High	High	Low	Low
1	1	1	0	High	High	High	Low
1	1	1	1	High	High	High	High

¹<V_{TH} = 0.

²>V_{TH} = 1.

Figure 18 and Figure 19 show waveforms that illustrate the behavior of the ADM1184.

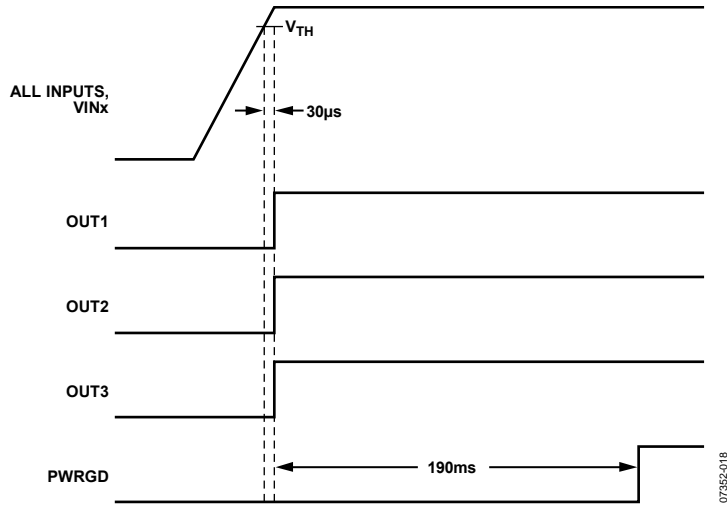

Figure 18. Power-Up Waveforms

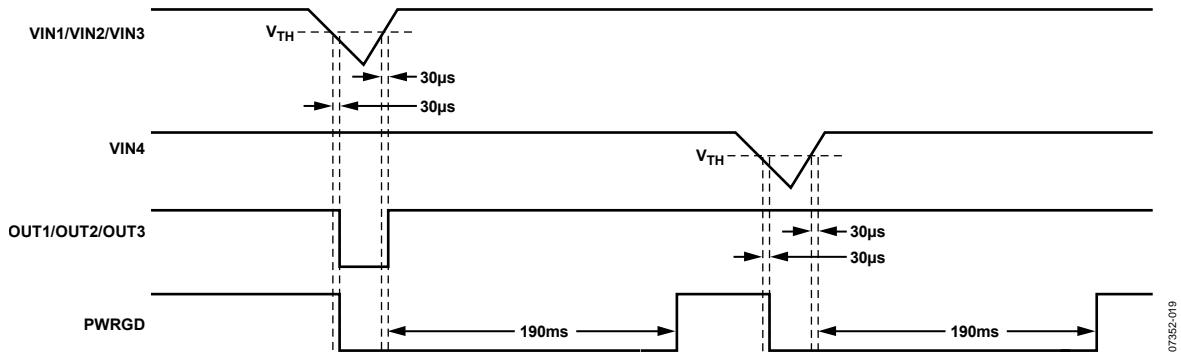

Figure 19. Waveforms Showing Reaction to a Temporary Low Glitch on VIN1, VIN2, VIN3, or VIN4

OUTLINE DIMENSIONS

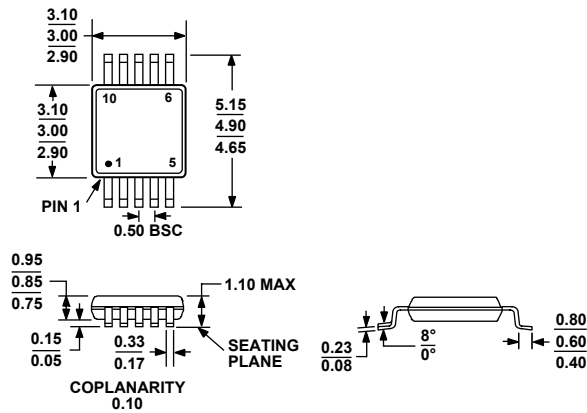

Figure 21. 10-Lead Mini Small Outline Package [MSOP] (RM-10)
Dimensions shown in millimeters

ORDERING GUIDE

Model	Temperature Range	Package Description	Package Option	Branding
ADM1184ARMZ ¹	-40°C to +85°C	10-Lead Mini Small Outline Package [MSOP]	RM-10	MBO
ADM1184ARMZ-REEL7 ¹	-40°C to +85°C	10-Lead Mini Small Outline Package [MSOP]	RM-10	MBO

¹ Z = RoHS Compliant Part.