

# Adjustable Frequency Current Mode Flyback DC/DC Controller

## FEATURES

- $V_{IN}$  and  $V_{OUT}$  Limited Only by External Components
- Adjustable Slope Compensation
- Adjustable Overcurrent Protection with Automatic Restart
- Adjustable Operating Frequency (70kHz to 700kHz) with One External Resistor
- Synchronizable to an External Clock
- $\pm 1.5\%$  Reference Accuracy
- Current Mode Operation for Excellent Line and Load Transient Response
- RUN Pin with Precision Threshold and Adjustable Hysteresis
- Programmable Soft-Start with One External Capacitor
- Low Quiescent Current: 360 $\mu$ A
- Small 10-Lead MSOP and 3mm  $\times$  3mm DFN

## APPLICATIONS

- Telecom Power Supplies
- 42V and 12V Automotive Power Supplies
- Isolated Electronic Equipment

## DESCRIPTION

The LTC<sup>®</sup>3805 is a current mode controller for flyback DC/DC converters designed to drive an N-channel MOSFET in high input and output voltage converter applications. Operating frequency and slope compensation can be programmed by external resistors. Programmable overcurrent sensing protects the converter from short-circuits. Soft-start can be programmed using an external capacitor and the soft-start capacitor also programs an automatic restart feature.

The LTC3805 provides  $\pm 1.5\%$  output voltage accuracy and consumes only 360 $\mu$ A of quiescent current during normal operation and only 40 $\mu$ A during micropower start-up. Using a 9.5V internal shunt regulator, the LTC3805 can be powered from a high  $V_{IN}$  through a resistor or it can be powered directly from a low impedance DC voltage of 9V or less.

The LTC3805 is available in the 10-lead MSOP package and the 3mm  $\times$  3mm DFN package.

LT, LT, LTC, LTM, Linear Technology and the Linear logo are registered trademarks of Linear Technology Corporation. All other trademarks are the property of their respective owners.

## TYPICAL APPLICATION

36V – 72V to 5V/2A Nonisolated Flyback Converter

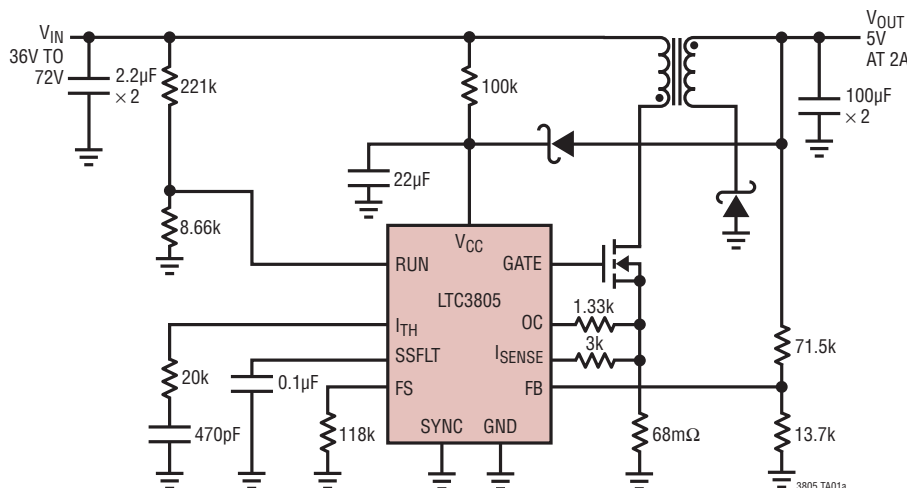

Efficiency and Power Loss vs Load Current;  $V_0 = 5V$

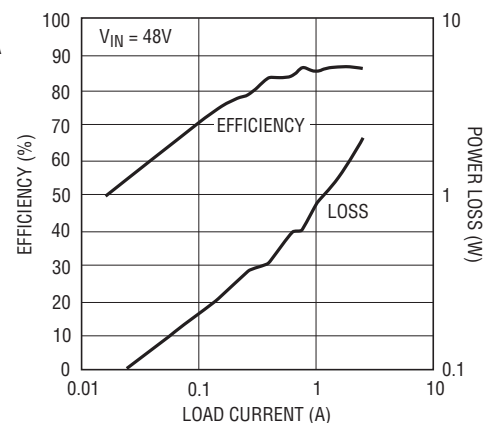

3805 TA01b

# LTC3805

## ABSOLUTE MAXIMUM RATINGS (Note 1)

$V_{CC}$ to GND	
Low Impedance Source .....	-0.3V to 8.8V
Current Fed .....	25mA into $V_{CC}$ *
SYNC .....	-0.3V to 6V
SSFLT .....	-0.3V to 5V
FB, $I_{TH}$ , FS .....	-0.3V to 3.5V
RUN .....	-0.3V to 18V
OC, $I_{SENSE}$ .....	-0.3V to 1V

Operating Junction Temperature Range (Notes 2, 3)	
E-Grade.....	-40°C to 85°C
I-Grade.....	-40°C to 125°C
H-Grade .....	-40°C to 150°C
Storage Temperature Range.....	-65°C to 125°C
Lead Temperature (Soldering, 10 sec)	
MSE Package .....	300°C

\*LTC3805 internal clamp circuit regulates  $V_{CC}$  voltage to 9.5V

## PIN CONFIGURATION



## ORDER INFORMATION

LEAD FREE FINISH	TAPE AND REEL	PART MARKING*	PACKAGE DESCRIPTION	TEMPERATURE RANGE
LTC3805EDD#PBF	LTC3805EDD#TRPBF	LCJM	10-Lead (3mm × 3mm) Plastic DFN	-40°C to 85°C
LTC3805IDD#PBF	LTC3805IDD#TRPBF	LCJM	10-Lead (3mm × 3mm) Plastic DFN	-40°C to 125°C
LTC3805EMSE#PBF	LTC3805EMSE#TRPBF	LTCJK	10-Lead Plastic MSOP	-40°C to 85°C
LTC3805IMSE#PBF	LTC3805IMSE#TRPBF	LTCJK	10-Lead Plastic MSOP	-40°C to 125°C
LTC3805HMSE#PBF	LTC3805HMSE#TRPBF	LTCJK	10-Lead Plastic MSOP	-40°C to 150°C
LEAD BASED FINISH	TAPE AND REEL	PART MARKING*	PACKAGE DESCRIPTION	TEMPERATURE RANGE
LTC3805EDD	LTC3805EDD#TR	LCJM	10-Lead (3mm × 3mm) Plastic DFN	-40°C to 85°C
LTC3805IDD	LTC3805IDD#TR	LCJM	10-Lead (3mm × 3mm) Plastic DFN	-40°C to 125°C
LTC3805EMSE	LTC3805EMSE#TR	LTCJK	10-Lead Plastic MSOP	-40°C to 85°C
LTC3805IMSE	LTC3805IMSE#TR	LTCJK	10-Lead Plastic MSOP	-40°C to 125°C
LTC3805HMSE	LTC3805HMSE#TR	LTCJK	10-Lead Plastic MSOP	-40°C to 150°C

Consult LTC Marketing for parts specified with wider operating temperature ranges. \*The temperature grade is identified by a label on the shipping container.

For more information on lead free part marking, go to: <http://www.linear.com/leadfree/>

For more information on tape and reel specifications, go to: <http://www.linear.com/tapeandree/>

## ELECTRICAL CHARACTERISTICS

The ● denotes the specifications which apply over the full operating junction temperature range, otherwise specifications are at  $T_A = 25^\circ\text{C}$ ,  $V_{CC} = 8\text{V}$ , unless otherwise noted (Note 2).

SYMBOL	PARAMETER	CONDITIONS	MIN	TYP	MAX	UNITS	
$V_{\text{TURNON}}$	$V_{CC}$ Turn-On Voltage	●	7.75	8.4	9	V	
$V_{\text{TURNOFF}}$	$V_{CC}$ Turn-Off Voltage	●	3.75	3.95	4.15	V	
$V_{\text{HYST}}$	$V_{CC}$ Hysteresis			4.5		V	
$V_{\text{CLAMP1mA}}$	$V_{CC}$ Shunt Regulator Voltage	$I_{CC} = 1\text{mA}$ , $V_{\text{RUN}} = 0$	●	8.8	9.25	9.65	V
$V_{\text{CLAMP25mA}}$	$V_{CC}$ Shunt Regulator Voltage	$I_{CC} = 25\text{mA}$ , $V_{\text{RUN}} = 0$	●	8.9	9.5	9.9	V
$I_{CC}$	Input DC Supply Current	Normal Operation ( $f_{\text{OSC}} = 200\text{kHz}$ ) (Note 4)			360		$\mu\text{A}$
		$V_{\text{RUN}} < V_{\text{RUNON}}$ or $V_{CC} < V_{\text{TURNON}} - 100\text{mV}$ (Micropower Start-Up)	●		40	90	$\mu\text{A}$
$V_{\text{RUNON}}$	RUN Turn-On Voltage	$V_{CC} = V_{\text{TURNON}} + 100\text{mV}$	●	1.122	1.207	1.292	V
$V_{\text{RUNOFF}}$	RUN Turn-Off Voltage	$V_{CC} = V_{\text{TURNON}} + 100\text{mV}$	●	1.092	1.170	1.248	V
$I_{\text{RUN(HYST)}}$	RUN Hysteresis Current		●	4	5	5.8	$\mu\text{A}$
$V_{\text{FB}}$	Regulated Feedback Voltage	$0^\circ\text{C} \leq T_A \leq 85^\circ\text{C}$ (Note 5)	●	0.788	0.800	0.812	V
		$-40^\circ\text{C} \leq T_A \leq 85^\circ\text{C}$ (Note 5)	●	0.780	0.800	0.812	V
		$-40^\circ\text{C}$ to $150^\circ\text{C}$	●	0.770	0.800	0.820	V
$I_{\text{FB}}$	$V_{\text{FB}}$ Input Current	$V_{\text{ITH}} = 1.3\text{V}$ (Note 5)			20	nA	
$g_m$	Error Amplifier Transconductance	$I_{\text{TH}}$ Pin Load = $\pm 5\mu\text{A}$ (Note 5)			333	$\mu\text{A/V}$	
$\Delta V_{\text{O(LINE)}}$	Output Voltage Line Regulation	$V_{\text{TURNOFF}} < V_{CC} < V_{\text{CLAMP1mA}}$ (Note 5)			0.05	mV/V	
$\Delta V_{\text{O(LOAD)}}$	Output Voltage Load Regulation	$I_{\text{TH}}$ Sinking $5\mu\text{A}$ (Note 5)			3	mV/ $\mu\text{A}$	
		$I_{\text{TH}}$ Sourcing $5\mu\text{A}$ (Note 5)			3	mV/ $\mu\text{A}$	
$f_{\text{OSC}}$	Oscillator Frequency	$R_{\text{FS}} = 350\text{k}$			70	kHz	
		$R_{\text{FS}} = 36\text{k}$			700	kHz	
$\text{DC}_{\text{ON(MIN)}}$	Minimum Switch-On Duty Cycle	$f_{\text{OSC}} = 200\text{kHz}$			6	9	%
$\text{DC}_{\text{ON(MAX)}}$	Maximum Switch-On Duty Cycle	$f_{\text{OSC}} = 200\text{kHz}$		70	80	95	%
$f_{\text{SYNC}}$	As a Function of $f_{\text{OSC}}$	$70\text{kHz} < f_{\text{OSC}} < 700\text{kHz}$ , $70\text{kHz} < f_{\text{SYNC}} < 700\text{kHz}$			67	133	%
$V_{\text{SYNC}}$	Minimum SYNC Amplitude					2.9	V
$I_{\text{SS}}$	Soft-Start Current				-6		$\mu\text{A}$
$I_{\text{FTO}}$	Fault Timeout Current				2		$\mu\text{A}$
$t_{\text{SS(INT)}}$	Internal Soft-Start Time	No External Capacitor on SSFLT			1.8		ms
$t_{\text{FTO(INT)}}$	Internal Fault Timeout	No External Capacitor on SSFLT			4.5		ms
$t_{\text{RISE}}$	Gate Drive Rise Time	$C_{\text{LOAD}} = 3000\text{pF}$			30		ns
$t_{\text{FALL}}$	Gate Drive Fall Time	$C_{\text{LOAD}} = 3000\text{pF}$			30		ns
$V_{\text{I(MAX)}}$	Peak Current Sense Voltage	$R_{\text{SL}} = 0$ (Note 6)	●	85	100	115	mV
$I_{\text{SL(MAX)}}$	Peak Slope Compensation Output Current	(Note 7)			10		$\mu\text{A}$
$V_{\text{OCT}}$	Overcurrent Threshold	$R_{\text{OC}} = 0$ (Note 8)	●	85	100	115	mV
$I_{\text{OC}}$	Overcurrent Threshold Adjust Current				10		$\mu\text{A}$

## ELECTRICAL CHARACTERISTICS

**Note 1:** Stresses beyond those listed under Absolute Maximum Ratings may cause permanent damage to the device. Exposure to any Absolute Maximum Rating condition for extended periods may affect device reliability and lifetime.

**Note 2:** The LTC3805E is guaranteed to meet specifications from 0°C to 85°C. Specifications over the –40°C to 85°C operating junction temperature range are assured by design, characterization and correlation with statistical process controls. The LTC3805I is guaranteed over the –40°C to 125°C operating junction temperature range, and the LTC3805H is guaranteed over the full –40°C to 150°C operating junction temperature range. High junction temperatures degrade operating lifetimes. Operating lifetime is derated at junction temperatures greater than 125°C.

**Note 3:**  $T_J$  is calculated from the ambient temperature  $T_A$  and power dissipation  $P_D$  according to the following formula:

$$T_J = T_A + (P_D \cdot 45^\circ\text{C/W})$$

**Note 4:** Dynamic supply current is higher due to the gate charge being delivered at the switching frequency.

**Note 5:** The LTC3805 is tested in a feedback loop that servos  $V_{FB}$  to the output of the error amplifier while maintaining  $I_{TH}$  at the midpoint of the current limit range.

**Note 6:** Peak current sense voltage is reduced dependent on duty cycle and an optional external resistor in series with the SENSE pin. For details, refer to Programmable Slope Compensation in the Applications Information section.

**Note 7:** Guaranteed by design.

**Note 8:** Overcurrent threshold voltage is reduced dependent on an optional external resistor in series with the OC pin. For details, refer to Programmable Overcurrent in the Applications Information section.

# TYPICAL PERFORMANCE CHARACTERISTICS

**Reference Voltage vs Temperature**

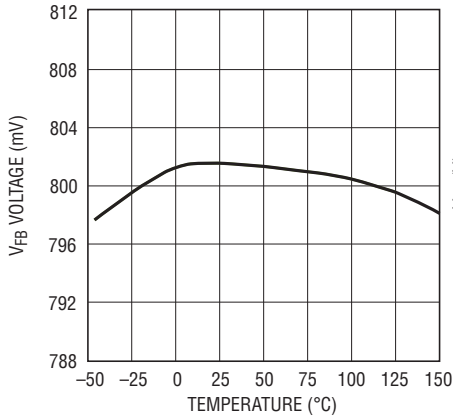

3805 G01

**Reference Voltage vs Supply Voltage**

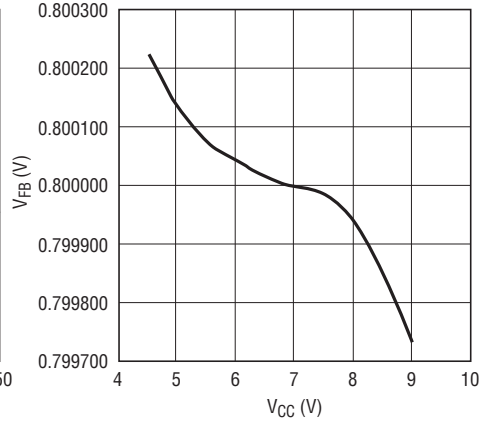

3805 G02

**Oscillator Frequency vs R<sub>FS</sub>**

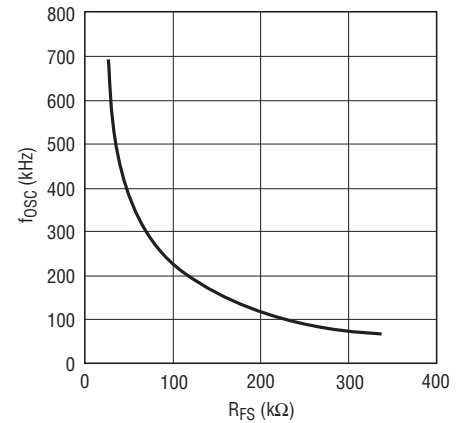

3805 G03

**Oscillator Frequency vs Supply Voltage**

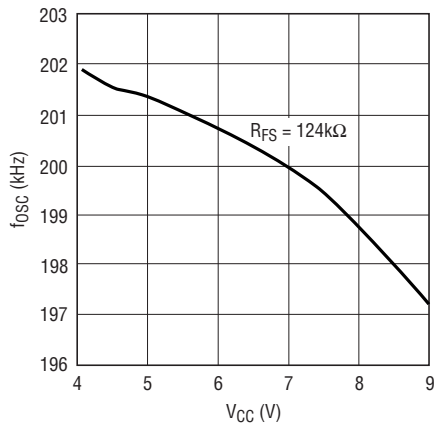

3805 G04

**Oscillator Frequency vs Temperature**

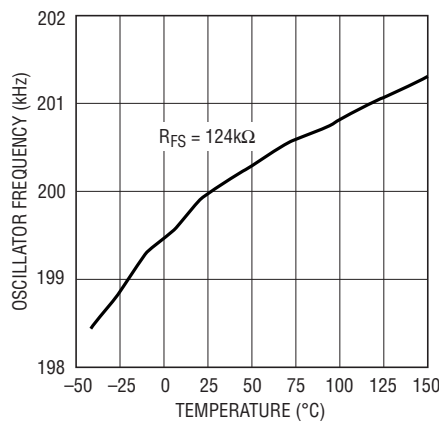

3805 G05

**RUN Undervoltage Lockout Thresholds vs Temperature**

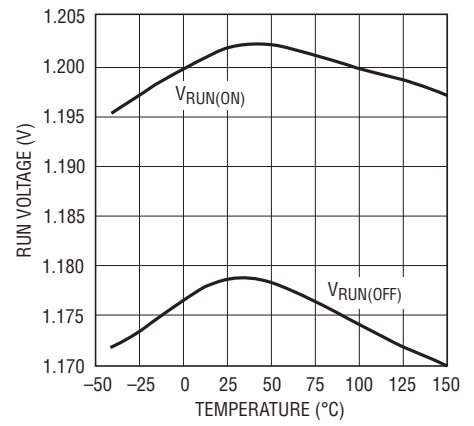

3805 G06

**RUN Hysteresis Current vs Temperature**

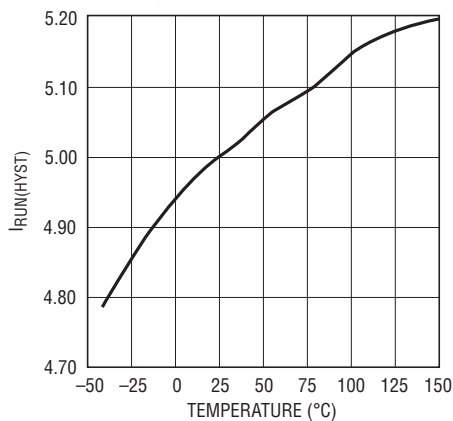

3805 G07

**V<sub>CC</sub> Undervoltage Lockout Thresholds vs Temperature**

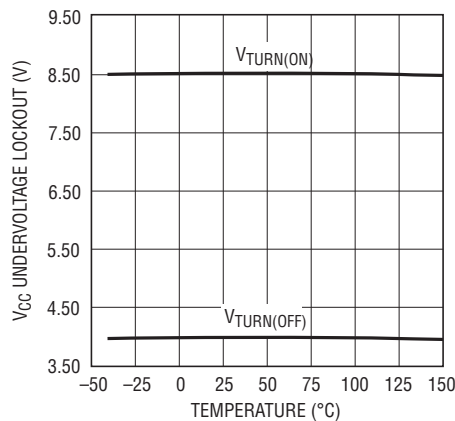

3805 G08

**Start-Up I<sub>CC</sub> Supply Current vs Temperature**

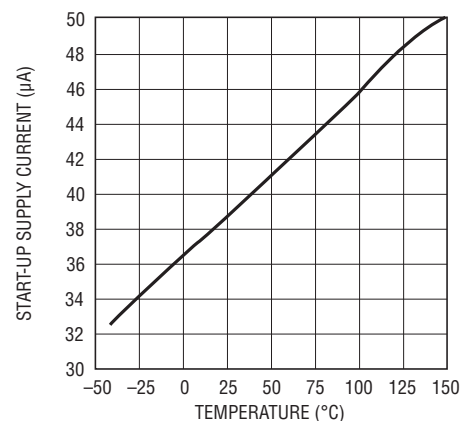

3805 G09

## TYPICAL PERFORMANCE CHARACTERISTICS

**I<sub>CC</sub> Supply Current vs Temperature**

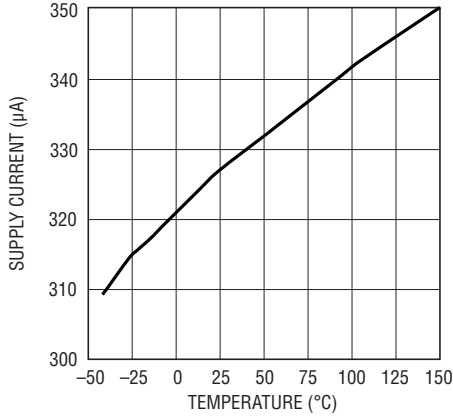

3805 G10

**V<sub>CC</sub> Shunt Regulator Voltage vs Temperature**

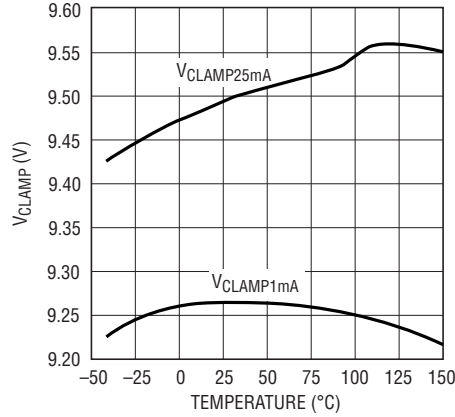

3805 G11

**Peak Current Sense Voltage vs Temperature**

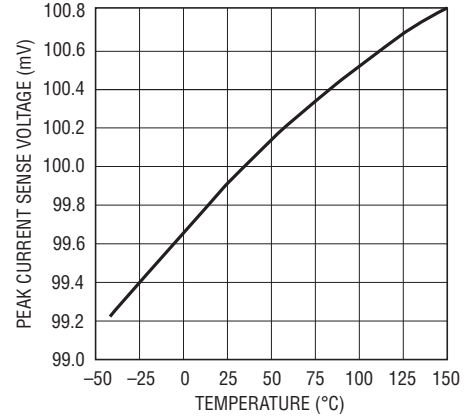

3805 G12

**Overcurrent Threshold vs Temperature**

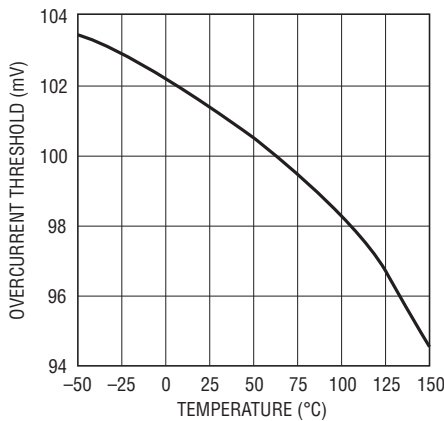

3805 G13

**Internal Soft-Start Time vs Temperature**

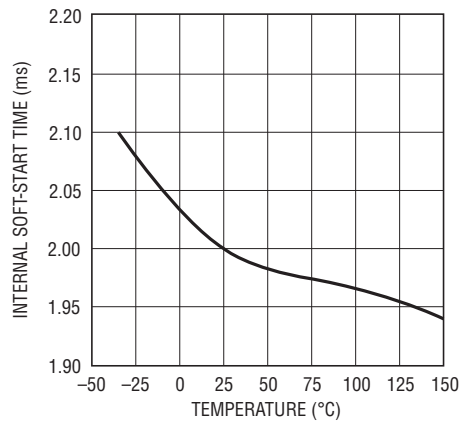

3805 G14

**External Soft-Start Current vs Temperature**

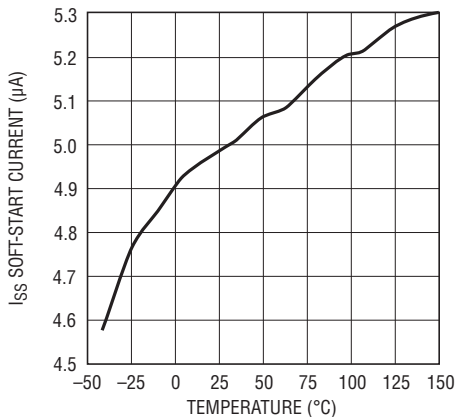

3805 G15

**External Timeout Current vs Temperature**

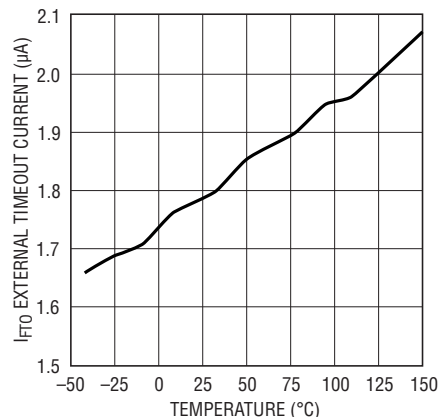

3805 G16

## PIN FUNCTIONS

**SSFLT (Pin 1):** Soft-Start Pin. A capacitor placed from this pin to GND (Exposed Pad) controls the rate of rise of converter output voltage during start-up. This capacitor is also used for time out after a fault prior to restart.

**I<sub>TH</sub> (Pin 2):** Error Amplifier Compensation Point. Normal operating voltage range is clamped between 0.7V and 1.9V.

**FB (Pin 3):** Receives the feedback voltage from an external resistor divider across the output.

**RUN (Pin 4):** An external resistor divider connects this pin to V<sub>IN</sub> and sets the thresholds for converter operation.

**FS (Pin 5):** A resistor connected from this pin to ground sets the frequency of operation.

**SYNC (Pin 6):** Input to synchronize the oscillator to an external source.

**I<sub>SENSE</sub> (Pin 7):** Performs two functions: for current mode control, it monitors the switch current, using the voltage across an external current sense resistor. Pin 7 also injects a current ramp that develops slope compensation voltage across an optional external programming resistor.

**OC (Pin 8):** Overcurrent Pin. Connect this pin to the external switch current sense resistor. An additional resistor programs the overcurrent trip level.

**V<sub>CC</sub> (Pin 9):** Supply Pin. A capacitor must closely decouple V<sub>CC</sub> to GND (Exposed Pad).

**GATE (Pin 10):** Gate Drive for the External N-channel MOSFET. This pin swings from GND to V<sub>CC</sub>.

**Exposed Pad (Pin 11):** Ground. A capacitor must closely decouple GND to V<sub>CC</sub> (Pin 9). Must be soldered to electrical ground on PCB.

## BLOCK DIAGRAM

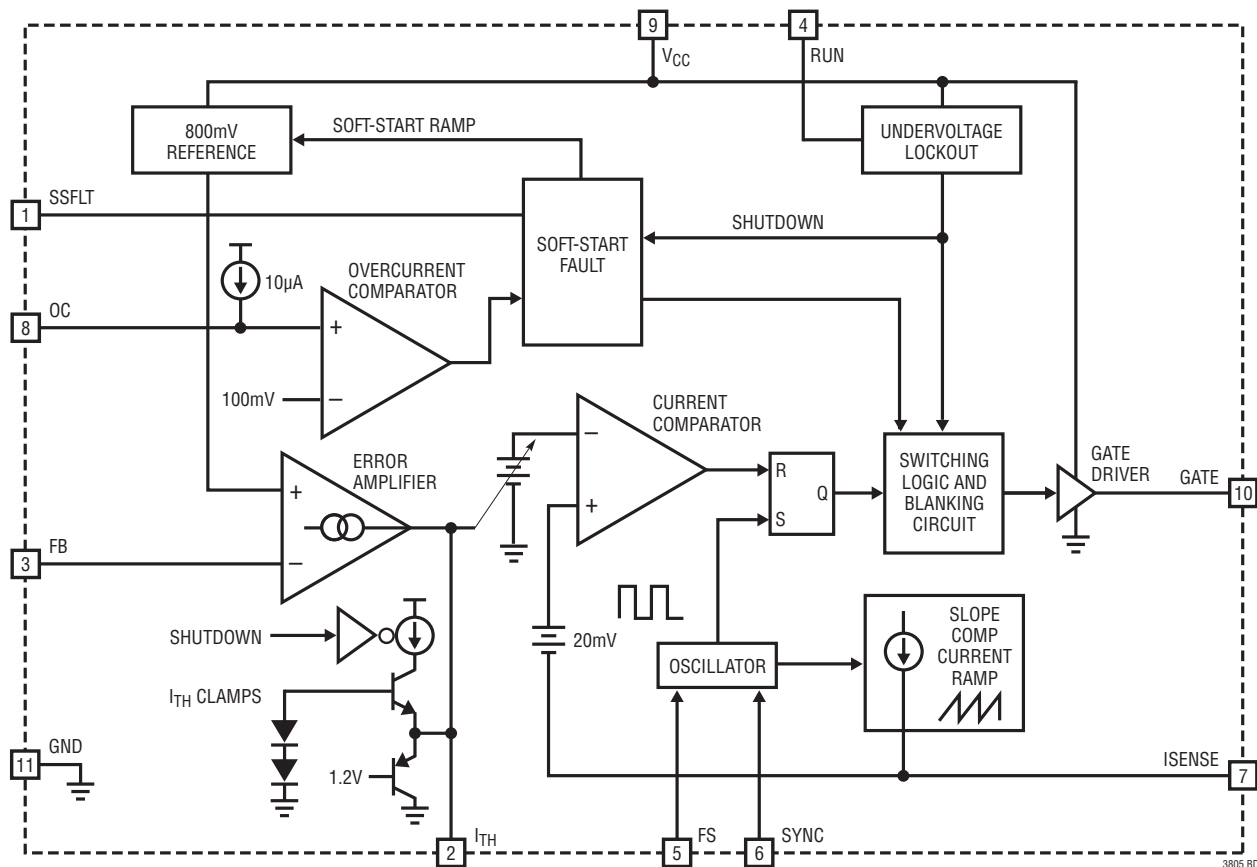

3805fd

## OPERATION

The LTC3805 is a programmable-frequency current mode controller for flyback, boost and SEPIC DC/DC converters. The LTC3805 is designed so that none of its pins need to come in contact with the input or output voltages of the power supply circuit of which it is a part, allowing the conversion of voltages well beyond the LTC3805's absolute maximum ratings.

### Main Control Loop

Please refer to the Block Diagram of this data sheet and the Typical Application shown on the front page. An external resistive voltage divider presents a fraction of the output voltage to the FB pin. The divider is designed so that when the output is at the desired voltage, the FB pin voltage equals the 800mV internal reference voltage. If the load current increases, the output voltage decreases slightly, causing the FB pin voltage to fall below the 800mV reference. The error amplifier responds by feeding current into the  $I_{TH}$  pin causing its voltage to rise. Conversely, if the load current decreases, the FB voltage rises above the 800mV reference and the error amplifier sinks current away from the  $I_{TH}$  pin causing its voltage to fall.

The voltage at the  $I_{TH}$  pin controls the pulse-width modulator formed by the oscillator, current comparator and SR latch. Specifically, the voltage at the  $I_{TH}$  pin sets the current comparator's trip threshold. The current comparator's  $I_{SENSE}$  input monitors the voltage across an external current sense resistor in series with the source of the external MOSFET. At the start of a cycle, the LTC3805's oscillator sets the SR latch and turns on the external power MOSFET. The current through the external power MOSFET rises as

does the voltage on the  $I_{SENSE}$  pin. The LTC3805's current comparator trips when the voltage on the  $I_{SENSE}$  pin exceeds a voltage proportional to the voltage on the  $I_{TH}$  pin. This resets the SR latch and turns off the external power MOSFET. In this way, the peak current levels through the external MOSFET and the flyback transformer's primary and secondary windings are controlled by the voltage on the  $I_{TH}$  pin. If the current comparator does not trip, the LTC3805 automatically limits the duty cycle to 80%, resets the SR latch, and turns off the external MOSFET.

The path from the FB pin, through the error amplifier, current comparator and the SR latch implements the closed-loop current-mode control required to regulate the output voltage against changes in input voltage or output current. For example, if the load current increases, the output voltage decreases slightly, and sensing this, the error amplifier sources current from the  $I_{TH}$  pin, raising the current comparator threshold, thus increasing the peak currents through the transformer primary and secondary. This delivers more current to the load and restores the output voltage to the desired level.

The  $I_{TH}$  pin serves as the compensation point for the control loop. Typically, an external series RC network is connected from  $I_{TH}$  to ground and is chosen for optimal response to load and line transients. The impedance of this RC network converts the output current of the error amplifier to the  $I_{TH}$  voltage which sets the current comparator threshold and commands considerable influence over the dynamics of the voltage regulation loop.

## OPERATION

### Start-Up/Shutdown

The LTC3805 has two shutdown mechanisms to disable and enable operation: an undervoltage lockout on the  $V_{CC}$  supply pin voltage, and a precision-threshold RUN pin. The voltage on both pins must exceed the appropriate threshold before operation is enabled. The LTC3805 transitions into and out of shutdown according to the state diagram shown in Figure 1. Operation in fault timeout is discussed in a subsequent section. During shutdown the LTC3805 draws only a small 40 $\mu$ A current.

The undervoltage lockout (UVLO) mechanism prevents the LTC3805 from trying to drive the external MOSFET gate with insufficient voltage on the  $V_{CC}$  pin. The voltage at the  $V_{CC}$  pin must initially exceed  $V_{TURNON} = 8.4V$  to enable LTC3805 operation. After operation is enabled, the voltage on the  $V_{CC}$  pin may fall as low as  $V_{TURNOFF} = 4V$  before undervoltage lockout disables the LTC3805. This wide UVLO hysteresis range supports the use of trickle charger powering schemes. See the Applications Information section for more detail.

The RUN pin is connected to the input voltage using a voltage divider. Converter operation is enabled when the voltage on the RUN pin exceeds  $V_{RUNON} = 1.207V$  and disabled when the voltage falls below  $V_{RUNOFF} = 1.170V$ . Additional hysteresis is added by a 5 $\mu$ A current source acting on the voltage divider's Thevenin resistance. Setting the input voltage range and hysteresis is further discussed in the Applications Information section.

### Setting the Oscillator Frequency

Connect a frequency set resistor  $R_{FS}$  from the FS pin to ground to set the oscillator frequency over a range from 70kHz to 700kHz. The oscillator frequency is calculated from:

$$f_{osc} = \frac{24 \cdot 10^9}{R_{FS} - 1500}$$

The oscillator may be synchronized to an external clock using the SYNC input. The rising edge of the external clock on the SYNC pin triggers the beginning of a switching period, i.e., the GATE pin going high. The pulse width of the external clock is quite flexible. The clock must stay high only for about 200ns to trigger the start of a new switching period. Conversely, the pulse width can be increased to a duty cycle not greater than 55%.

### Overcurrent Protection

With the OC pin connected to the external MOSFET's current sense resistor, the converter is protected in the event of an overload or short-circuit on the output. During normal operation the peak value of current in the external MOSFET, as measured by the current sense resistor (plus any adjustment for slope compensation), is set by the voltage on the  $I_{TH}$  pin operating through the current comparator. As the output current increases, so does the voltage on the  $I_{TH}$  pin and so does the peak MOSFET current.

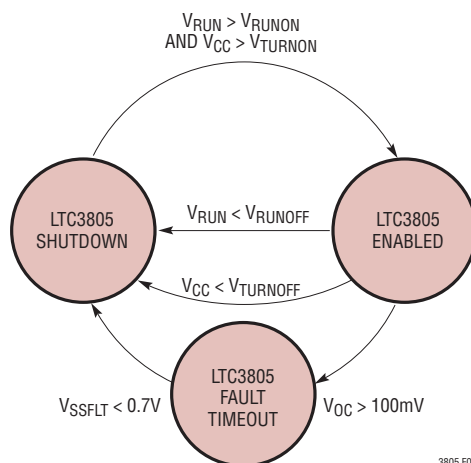

Figure 1. Start-Up/Shutdown State Diagram

## OPERATION

First, consider operation without overcurrent protection. For some maximum converter output current, the voltage on the  $I_{TH}$  pin rises to and is clamped at approximately 1.9V. This corresponds to a 100mV limit on the voltage at the  $I_{SENSE}$  pin. As the output current is further increased, the duty cycle is reduced as the output voltage sags. However, the peak current in the external MOSFET is limited by the 100mV threshold at the  $I_{SENSE}$  pin.

As the output current is increased further, eventually, the duty cycle is reduced to the 6% minimum. Since the external MOSFET is always turned on for this minimum amount of time, the current comparator no longer limits the current through the external MOSFET based on the 100mV threshold. If the output current continues to increase, the current through the MOSFET could rise to a level that would damage the converter.

To prevent damage, the overcurrent pin OC is also connected to the current sense resistor, and a fault is triggered if the voltage on the OC pin exceeds 100mV. To protect itself, the converter stops operating as described in the next section. External resistors can be used to adjust the overcurrent threshold to voltages higher or lower than 100mV as described in the Applications Information section.

### Soft-Start and Fault Timeout Operation

The soft-start and fault timeout of the LTC3805 uses either a fixed internal timer or an external timer programmed by a capacitor from the SSFLT pin to GND. The internal soft-start and fault timeout times are minimums and can be increased by placing a capacitor from the SSFLT pin to GND. Operation is shown in Figure 1.

Leave the SSFLT pin open to use the internal soft-start and fault timeout. The internal soft-start is complete in about 1.8ms. In the event of an overcurrent as detected by the OC pin exceeding 100mV, the LTC3805 shuts down and an internal timing circuit waits for a fault timeout of about 4.25ms and then restarts the converter.

Add a capacitor  $C_{SS}$  from the SSFLT pin to GND to increase both the soft-start time and the time for fault timeout. During soft-start,  $C_{SS}$  is charged with a 6 $\mu$ A current. When the LTC3805 comes out of shutdown, the LTC3805 quickly charges  $C_{SS}$  to about 0.7V at which point GATE begins switching. From that point, GATE continues switching with increasing duty cycle until the SSFLT pin reaches about 2.25V at which point soft-start is over and closed-loop regulation begins. The voltage on the SSFLT pin additionally further charges to about 4.75V.

$C_{SS}$  also performs the timeout function in the event of a fault. After a fault,  $C_{SS}$  is slowly discharged from about 4.75V to about 0.7V by a 2 $\mu$ A current. When the voltage on the SSFLT pin reaches 0.7V the converter attempts to restart. More detail on programming the external soft-start fault timeout is described in the Applications Information section.

### Powering the LTC3805

A built-in shunt regulator from the  $V_{CC}$  pin to GND limits the voltage on the  $V_{CC}$  pin to approximately 9.5V as long as the shunt regulator is not forced to sink more than 25mA. The shunt regulator is always active, even when the LTC3805 is in shutdown, since it serves the vital function of protecting the  $V_{CC}$  pin from overvoltage. The shunt regulator permits the use of a wide variety of powering schemes for the LTC3805 even from high voltage sources that exceed the LTC3805's absolute maximum ratings. Further details on powering schemes are described in the Applications Information section.

### Adjustable Slope Compensation

The LTC3805 injects a 10 $\mu$ A peak current ramp out of its  $I_{SENSE}$  pin which can be used, in conjunction with an external resistor, for slope compensation in designs that require it. This current ramp is approximately linear and begins at zero current at 6% duty cycle, reaching peak current at 80% duty cycle. Additional details are provided in the Applications Information section.

## APPLICATIONS INFORMATION

Many LTC3805 application circuits can be derived from the topology shown on the first page of this data sheet and from the topology shown in Figure 2.

The LTC3805 itself imposes no limits on allowed input voltage  $V_{IN}$  or output voltage  $V_{OUT}$ . These are all determined by the ratings of the external power components. The factors are: Q1 maximum drain-source voltage ( $B_{VDSS}$ ), on-resistance ( $R_{DS(ON)}$ ) and maximum drain current, T1 saturation flux level and winding insulation breakdown voltages,  $C_{IN}$  and  $C_{OUT}$  maximum working voltage, equivalent series resistance (ESR), and maximum ripple current ratings, and D1 and  $R_{SENSE}$  power ratings.

### $V_{CC}$ Bias Power

The  $V_{CC}$  pin must be bypassed to the GND pin with a minimum  $1\mu\text{F}$  ceramic or tantalum capacitor located immediately adjacent to the two pins. Proper supply bypassing is necessary to supply the high transient currents required by the MOSFET gate driver.

For maximum flexibility, the LTC3805 is designed so that it can be operated from voltages well beyond the LTC3805's absolute maximum ratings. Figure 2 shows the simplest case, in which the LTC3805 is powered with a resistor  $R_{VCC}$  connected between the input voltage and  $V_{CC}$ . The

built-in shunt regulator limits the voltage on the  $V_{CC}$  pin to around 9.5V as long as the internal shunt regulator is not forced to sink more than 25mA. This powering scheme has the drawback that the power loss in the resistor reduces converter efficiency and the 25mA shunt regulator maximum may limit the maximum-to-minimum range of input voltage.

In some cases, the input or output voltage is within the operational range of  $V_{CC}$  for the LTC3805. In this case, the LTC3805 is operated directly from either the input or output voltage. Figure 3 shows a 5V output converter in which  $R_{START}$  and  $C_{VCC}$  form a start-up trickle charger while D2 powers  $V_{CC}$  from the output once the converter is in normal operation. Note that  $R_{START}$  need only supply the very small  $40\mu\text{A}$  micropower start-up current while

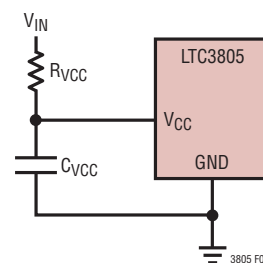

Figure 2. Powering the LTC3805 via the Internal Shunt Regulator

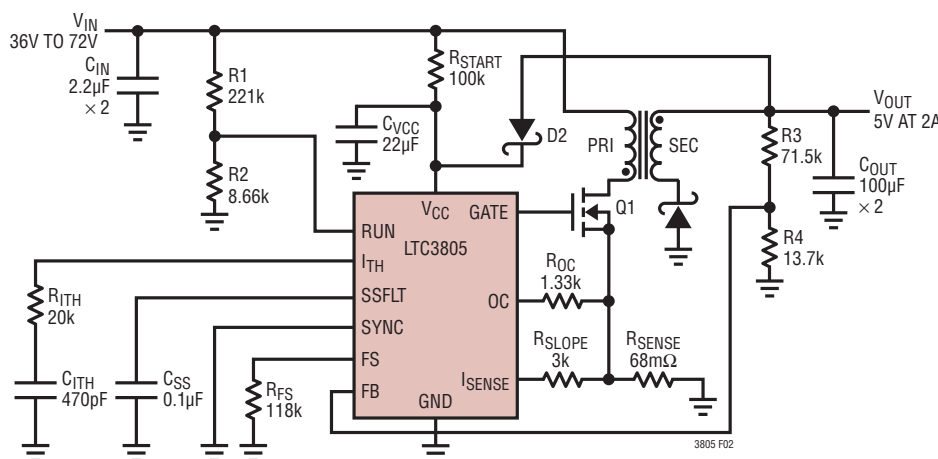

Figure 3. Powering the LTC3805 from the Output

## APPLICATIONS INFORMATION

$C_{VCC}$  is charged to  $V_{TURNON}$ . At this point, assuming  $V_{RUN} > V_{RUNON}$ , the converter begins switching the external MOSFET and ramps up the converter output voltage at a rate set by the capacitor  $C_{SS}$  on the SSFLT pin. Since  $R_{START}$  cannot supply enough current to operate the external MOSFET,  $C_{VCC}$  begins discharging and  $V_{CC}$  drops. The soft-start must be fast enough and the discharge of  $C_{VCC}$  slow enough so that the output voltage reaches its target value of 5V before  $V_{CC}$  drops to  $V_{TURNOFF}$  or the converter would fail to start.

The typical application circuit in Figure 9 shows a different flyback converter bias power strategy for a case in which neither the input or output voltage is suitable for providing bias power to the LTC3805. A small NPN preregulator transistor and a Zener diode are used to accelerate the rise of  $V_{CC}$  and reduce the value of the  $V_{CC}$  bias capacitor. The flyback transformer has an additional bias winding to provide bias power. Note that this topology is very powerful because, by appropriate choice of transformer turns ratio, the output voltage can be chosen without regard to the value of the input voltage or the  $V_{CC}$  bias power for the LTC3805. The number of turns in the bias winding is chosen according to

$$N_{BIAS} = N_{SEC} \frac{V_{CC} + V_{D4}}{V_{OUT} - V_{D1}}$$

where  $N_{BIAS}$  is the number of turns in the bias winding,  $N_{SEC}$  is the number of turns in the secondary winding,  $V_{CC}$  is the desired voltage to power the LTC3805,  $V_{OUT}$  is the converter output voltage,  $V_{D1}$  is the forward voltage drop of D1 and  $V_{D4}$  is the forward voltage drop of D4.

Note that since  $V_{OUT}$  is regulated by the converter control loop,  $V_{CC}$  is also regulated although not as precisely. The value of  $V_{CC}$  is often constrained since  $N_{BIAS}$  and  $N_{SEC}$  are often a limited range of small integer numbers. For proper operation, the value of  $V_{CC}$  must be between  $V_{TURNON}$  and  $V_{TURNOFF}$ . Since the ratio of  $V_{TURNON}$  to  $V_{TURNOFF}$  is over two to one, this requirement is relatively easy to satisfy. Figure 10 shows a similar low power nonisolated telecom converter using a trickle charger.

### Transformer Design Considerations

Transformer specification and design is perhaps the most critical part of applying the LTC3805 successfully. In addition to the usual list of caveats dealing with high frequency power transformer design, the following should prove useful.

### Turns Ratios

Due to the use of the external feedback resistor divider ratio to set output voltage, the user has relative freedom in selecting transformer turns ratio to suit a given application. Simple ratios of small integers, e.g., 1:1, 2:1, 3:2, etc. can be employed which yield more freedom in setting total turns and transformer inductance. Simple integer turns ratios also facilitate the use of "off-the-shelf" configurable transformers. Turns ratio can be chosen on the basis of desired duty cycle. However, remember that the input supply voltage plus the secondary-to-primary referred version of the flyback pulse (including leakage spike) must not exceed the allowed external MOSFET breakdown rating.

## APPLICATIONS INFORMATION

### Leakage Inductance

Transformer leakage inductance (on either the primary or secondary) causes a voltage spike to occur after the MOSFET (Q1) turn-off. This is increasingly prominent at higher load currents, where more stored energy must be dissipated. In some cases an RC “snubber” circuit will be required to avoid overvoltage breakdown at the MOSFET’s drain node. Application Note 19 is a good reference on snubber design. A bifilar or similar winding technique is a good way to minimize troublesome leakage inductances. However, remember that this will limit the primary-to-secondary breakdown voltage, so bifilar winding is not always practical.

### Setting Undervoltage and Hysteresis on $V_{IN}$

The RUN pin is connected to a resistive voltage divider connected to  $V_{IN}$  as shown in Figure 4. The voltage threshold for the RUN pin is  $V_{RUNON}$  rising and  $V_{RUNOFF}$  falling. Note that  $V_{RUNON} - V_{RUNOFF} = 35\text{mV}$  of built-in voltage hysteresis that helps eliminate false trips.

To introduce further user-programmable hysteresis, the LTC3805 sources  $5\mu\text{A}$  out of the RUN pin when operation of LTC3805 is enabled. As a result, the falling threshold for the RUN pin also depends on the value of R1 and can be programmed by the user. The falling threshold for  $V_{IN}$  is therefore

$$V_{IN(RUN,FALLING)} = V_{RUNOFF} \cdot \frac{R1+R2}{R2} - R1 \cdot 5\mu\text{A}$$

where  $R1(5\mu\text{A})$  is the additional hysteresis introduced by the  $5\mu\text{A}$  current sourced by the RUN pin. When in shutdown, the RUN pin does not source the  $5\mu\text{A}$  current and the rising threshold for  $V_{IN}$  is simply

$$V_{IN(RUN,RISING)} = V_{RUNON} \cdot \frac{R1+R2}{R2}$$

### External Run/Stop Control

To implement external run control, place a small N-channel MOSFET from the RUN pin to GND as shown in Figure 4. Drive the gate of this MOSFET high to pull the RUN pin to ground and prevent converter operation.

### Selecting Feedback Resistor Divider Values

The regulated output voltage is determined by the resistor divider across  $V_{OUT}$  (R3 and R4 in Figure 2). The ratio of R4 to R3 needed to produce a desired  $V_{OUT}$  can be calculated:

$$R3 = \frac{V_{OUT} - 0.8\text{V}}{0.8\text{V}} R4$$

Choose resistance values for R3 and R4 to be as large as possible in order to minimize any efficiency loss due to the static current drawn from  $V_{OUT}$ , but just small enough so that when  $V_{OUT}$  is in regulation the input current to the  $V_{FB}$  pin is less than 1% of the current through R3 and R4. A good rule of thumb is to choose R4 to be less than 80k.

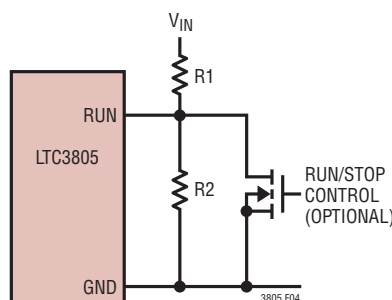

Figure 4. Setting RUN Pin Voltage and Run/Stop Control

## APPLICATIONS INFORMATION

### Feedback in Isolated Applications

Isolated applications do not use the FB pin and error amplifier but control the  $I_{TH}$  pin directly using an optoisolator driven on the other side of the isolation barrier as shown in Figure 5. A detailed version is shown in Figure 9. For isolated converters, the FB pin is grounded which provides pull-up on the  $I_{TH}$  pin. This pull-up is not enough to properly bias the optoisolator which is typically biased using a resistor to  $V_{CC}$ . Since the  $I_{TH}$  pin cannot sink the optoisolator bias current, a diode is required to block it from the  $I_{TH}$  pin. A low leakage Schottky diode or low forward voltage PN junction diode should be used to ensure that the optoisolator is able to pull  $I_{TH}$  down to its lower clamp.

### Oscillator Synchronization

The oscillator may be synchronized to an external clock by connecting the synchronization signal to the SYNC pin. The LTC3805 oscillator and turn-on of the switch are synchronized to the rising edge of the external clock. The frequency of the external sync signal must be  $\pm 33\%$  with respect to  $f_{OSC}$  (as programmed by  $R_{FS}$ ). Additionally, the value of  $f_{SYNC}$  must be between 70kHz and 700kHz.

### Current Sense Resistor Considerations

The external current sense resistor ( $R_{SENSE}$  in Figure 2) allows the user to optimize the current limit behavior for the particular application. As the current sense resistor is varied from several ohms down to tens of milliohms, peak switch current goes from a fraction of an ampere to several amperes. Care must be taken to ensure proper circuit operation, especially with small current sense resistor values.

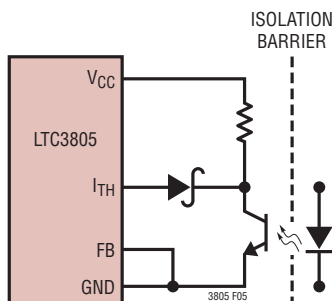

Figure 5. Circuit for Isolated Feedback

For example, with the peak current sense voltage of 100mV on the  $I_{SENSE}$  pin, a peak switch current of 5A requires a sense resistor of  $0.020\Omega$ . Note that the instantaneous peak power in the sense resistor is 0.5W and it must be rated accordingly. The LTC3805 has only a single sense line to this resistor. Therefore, any parasitic resistance in the ground side connection of the sense resistor will increase its apparent value. In the case of a  $0.020\Omega$  sense resistor, one milliohm of parasitic resistance will cause a 5% reduction in peak switch current. So the resistance of printed circuit copper traces and vias cannot necessarily be ignored.

### Programmable Slope Compensation

The LTC3805 injects a ramping current through its  $I_{SENSE}$  pin into an external slope compensation resistor  $R_{SLOPE}$ . This current ramp starts at zero right after the GATE pin has been high for the LTC3805's minimum duty cycle of 6%. The current rises linearly towards a peak of  $10\mu A$  at the maximum duty cycle of 80%, shutting off once the GATE pin goes low. A series resistor  $R_{SLOPE}$  connecting the  $I_{SENSE}$  pin to the current sense resistor  $R_{SENSE}$  develops a ramping voltage drop. From the perspective of the  $I_{SENSE}$  pin, this ramping voltage adds to the voltage across the sense resistor, effectively reducing the current comparator threshold in proportion to duty cycle. This stabilizes the control loop against subharmonic oscillation. The amount of reduction in the current comparator threshold ( $\Delta V_{SENSE}$ ) can be calculated using the following equation:

$$\Delta V_{SENSE} = \frac{\text{Duty Cycle} - 6\%}{80\%} 10\mu A \cdot R_{SLOPE}$$

Note: LTC3805 enforces  $6\% < \text{Duty Cycle} < 80\%$ . A good starting value for  $R_{SLOPE}$  is 3k, which gives a 30mV drop in current comparator threshold at 80% duty cycle. Designs that do not operate at greater than 50% duty cycle do not need slope compensation and may replace  $R_{SLOPE}$  with a direct connection.

## APPLICATIONS INFORMATION

### Overcurrent Threshold Adjustment

Figure 6 shows the connection of the overcurrent pin OC along with the  $I_{SENSE}$  pin and the current sense resistor  $R_{SENSE}$  located in the source circuit of the power NMOS which is driven by the GATE pin. The internal overcurrent threshold on the OC pin is set at  $V_{OCT} = 100\text{mV}$  which is the same as the peak current sense voltage  $V_{I(MAX)} = 100\text{mV}$  on the  $I_{SENSE}$  pin. The role of the slope compensation adjustment resistor  $R_{SLOPE}$  and the slope compensation current  $I_{SLOPE}$  is discussed in the prior section. In combination with the overcurrent threshold adjust current  $I_{OC} = 10\mu\text{A}$ , an external resistor  $R_{OC}$  can be used to lower the overcurrent trip threshold from  $100\text{mV}$ . This section describes how to pick  $R_{OC}$  to achieve the desired performance. In the discussion that follows be careful to distinguish between “current limit” where the converter continues to run with the  $I_{SENSE}$  pin limiting current on a cycle-by-cycle basis while the output voltage falls below the regulation point and “overcurrent protection” where the OC pin senses an overcurrent and shuts down the converter for a timeout period before attempting an automatic restart.

One overcurrent protection strategy is for the converter to never enter current limit but to maintain output voltage regulation up to the point of tripping the overcurrent protection. Operation at minimum input voltage  $V_{IN(MIN)}$  hits current limiting for the smallest output current and is the design point for this strategy.

First, for operation at  $V_{IN(MIN)}$ , calculate the duty cycle Duty Cycle  $V_{IN(MIN)}$  using the appropriate formula depending on whether the converter is a boost, flyback or SEPIC. Then

use Duty Cycle  $V_{IN(MIN)}$  to calculate  $\Delta V_{SENSE(VIN(MIN))}$  using the formula in the prior section. For overcurrent protection to trip at exactly the point where current limiting would begin set:

$$R_{OC(CRIT)} = \frac{\Delta V_{SENSE(VIN(MIN))}}{10\mu\text{A}}$$

To find the actual output current that trips overcurrent protection, calculate the peak switch current  $I_{PK(VIN(MIN))}$  from:

$$I_{PK(VIN(MIN))} = \frac{100\text{mV} - \Delta V_{SENSE(VIN(MIN))}}{R_{SENSE}}$$

Then calculate the converter output current that corresponds to  $I_{PK(VIN(MIN))}$ . Again, the calculation depends both on converter type and the details of converter design including inductor current ripple. For minimum input voltage,  $R_{OC(CRIT)}$  produces an overcurrent trip at an output current just before loss of output voltage regulation and the onset of current limiting. Note that the output current that causes an overcurrent trip is higher for higher input voltages but that an overcurrent trip will always occur before loss of output voltage regulation. If desired to meet a specific design target, an increase in  $R_{OC}$  above  $R_{OC(CRIT)}$  can be used to reduce the trip threshold and make the converter trip for a lower output current.

This calculation is based on steady-state operation. Depending on design, overcurrent protection can also be triggered during a start-up transient, particularly if large output filter capacitors are being charged as output voltage rises. If that is a problem, output capacitor charging can

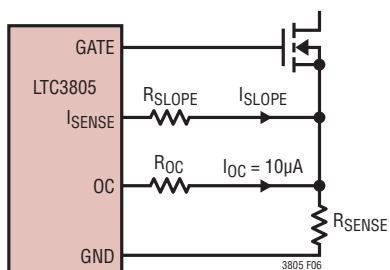

Figure 6. Circuit to Decrease Overcurrent Threshold

## APPLICATIONS INFORMATION

be slowed by using a larger value of SSFLT capacitor. It is also possible to trip overcurrent protection during a load step especially if the trip threshold is lowered by making  $R_{OC} > R_{OC(CRIT)}$ .

Another overcurrent protection strategy is keep the converter running as current limiting reduces the duty cycle and the output voltage sags. In this case, the goal is often keep the converter in normal operation over as wide a range as possible, including current limiting, and to trigger the overcurrent trip only to prevent damage. To implement this strategy use a value of  $R_{OC}$  smaller than  $R_{OC(CRIT)}$ . This also reduces sensitivity to overcurrent trips caused by transient operation. In the limit, set  $R_{OC} = 0$  and connect the OC pin directly to  $R_{SENSE}$ . This causes an overcurrent trip near minimum duty cycle or around 6%.

In some cases it may be desirable to increase the trip threshold even further. In this strategy, the converter is allowed to operate all the way down to minimum duty cycle at which point the cycle-by-cycle current limit of the  $I_{SENSE}$  pin is lost and switch current goes up proportionally to the output current. Figures 7 and 8 show two ways to do this. Figure 7 is for relatively low currents with relatively large values of  $R_{SENSE}$ . Using this circuit the overcurrent trip threshold is increased from 100mV to:

$$V_{OC} = \frac{R_{SENSE1} + R_{SENSE2}}{R_{SENSE1}} 100\text{mV}$$

where it is assumed that the values of  $R_{SENSE1}$  and  $R_{SENSE2}$  are so small that the  $I_{OC} = 10\mu\text{A}$  threshold adjustment current produces a negligible change in  $V_{OC}$ .

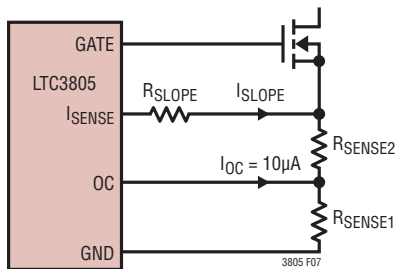

Figure 7. Circuit to Increase the Overcurrent Threshold for Small Switch Currents

For larger currents, values of the current sense resistors must be very small and the circuit of Figure 7 becomes impractical. The circuit of Figure 8 can be substituted and the current sense threshold is increased from 100mV to:

$$V_{OC} = \frac{R1 + R2}{R1} 100\text{mV}$$

where the values of R1 and R2 should be kept below  $10\Omega$  to prevent the  $I_{OC} = 10\mu\text{A}$  threshold adjustment current from producing a shift in  $V_{OC}$ .

### External Soft-Start Fault Timeout

The external soft-start is programmed by a capacitor  $C_{SS}$  from the SSFLT pin to GND. At the initiation of soft-start the voltage on the SSFLT pin is quickly charged to 0.7V at which point GATE begins switching. From that point, a  $6\mu\text{A}$  current charges the voltage on the SSFLT pin until the voltage reaches about 2.25V at which point soft-start is over and the converter enters closed-loop regulation. The soft-start time  $t_{SS(EXT)}$  as a function of the soft-start capacitor  $C_{SS}$  is therefore

$$t_{SS(EXT)} = C_{SS} \frac{2.25 - 0.7\text{V}}{6\mu\text{A}}$$

After soft-start is complete, the voltage on the SSFLT pin continues to charge to about a final value of 4.75V. Note that choosing a value of  $C_{SS}$  less than 5.8nF has no effect since it would attempt to program an external soft-start time  $t_{SS(EXT)}$  less than the mandatory minimum

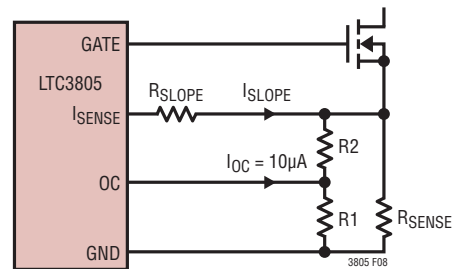

Figure 8. Circuit to Increase the Overcurrent Threshold for Large Switch Currents

## APPLICATIONS INFORMATION

internal soft-start time  $t_{SS(IN)} = 1.8\text{ms}$ . However, in noisy environments a small  $C_{SS}$  can be valuable to limit jitter in the oscillator.

If there is an overcurrent fault detected on the OC pin, the LTC3805 enters a shutdown mode while a  $2\mu\text{A}$  current discharges the voltage on the SSFLT pin from  $4.75\text{V}$  to about  $0.7\text{V}$ . The fault timeout  $t_{FTO(EXT)}$  is therefore

$$t_{FTO(EXT)} = C_{SS} \frac{4.75\text{V} - 0.7\text{V}}{2\mu\text{A}}$$

At this point, the LTC3805 attempts a restart.

In the event of a persistent fault, such as a short-circuit on the converter output, the converter enters a “hiccup” mode where it continues to try and restart at repetition rate determined by  $C_{SS}$ . If the fault is eventually removed the converter successfully restarts.

## TYPICAL APPLICATION

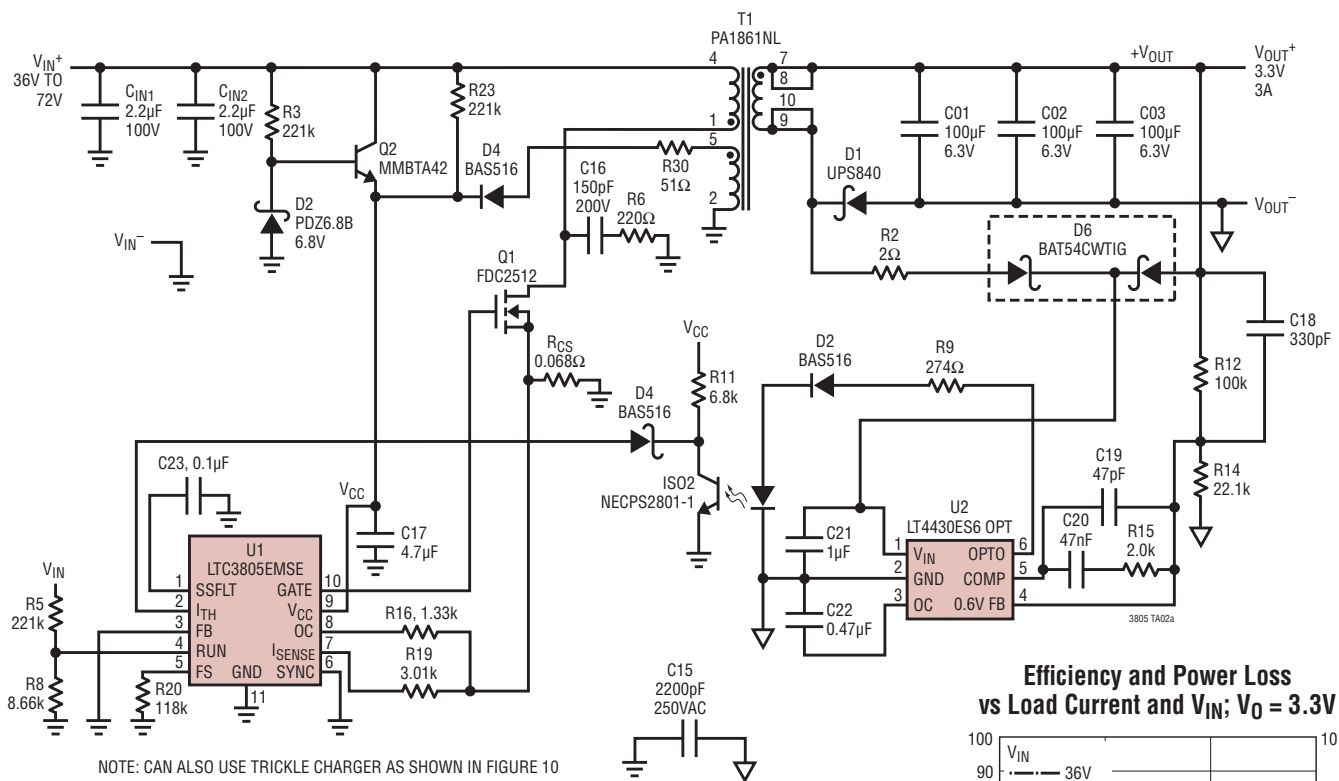
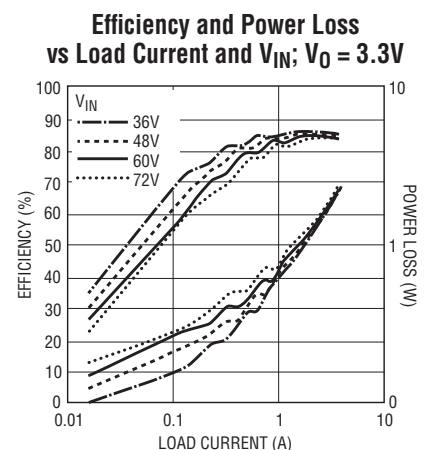

Figure 9. Low Power Isolated Telecom Supply with NPN Preregulator



3805 TA02b

3805fd

**PACKAGE DESCRIPTION**

**DD Package**  
**10-Lead Plastic DFN (3mm × 3mm)**  
 (Reference LTC DWG # 05-08-1699 Rev B)

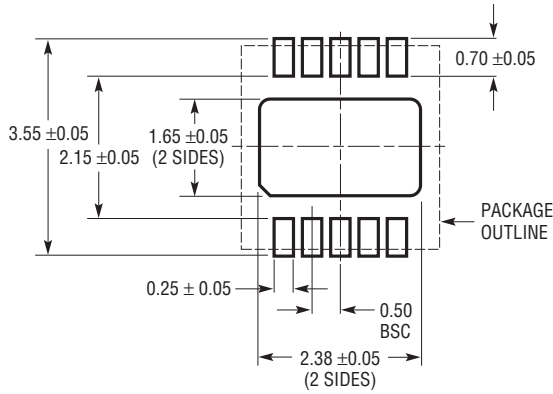

**RECOMMENDED SOLDER PAD PITCH AND DIMENSIONS**

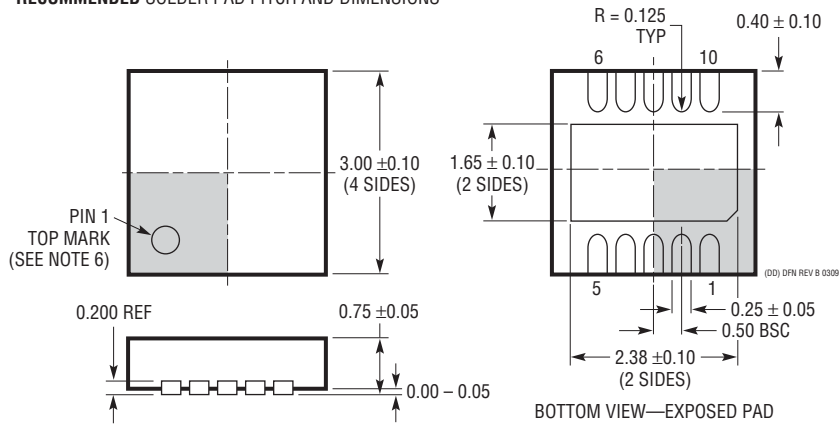

- NOTE:
1. DRAWING TO BE MADE A JEDEC PACKAGE OUTLINE M0-229 VARIATION OF (WEED-2). CHECK THE LTC WEBSITE DATA SHEET FOR CURRENT STATUS OF VARIATION ASSIGNMENT
  2. DRAWING NOT TO SCALE
  3. ALL DIMENSIONS ARE IN MILLIMETERS
  4. DIMENSIONS OF EXPOSED PAD ON BOTTOM OF PACKAGE DO NOT INCLUDE MOLD FLASH. MOLD FLASH, IF PRESENT, SHALL NOT EXCEED 0.15mm ON ANY SIDE
  5. EXPOSED PAD SHALL BE SOLDER PLATED
  6. SHADED AREA IS ONLY A REFERENCE FOR PIN 1 LOCATION ON THE TOP AND BOTTOM OF PACKAGE

# PACKAGE DESCRIPTION

## MSE Package 10-Lead Plastic MSOP (Reference LTC DWG # 05-08-1664 Rev C)

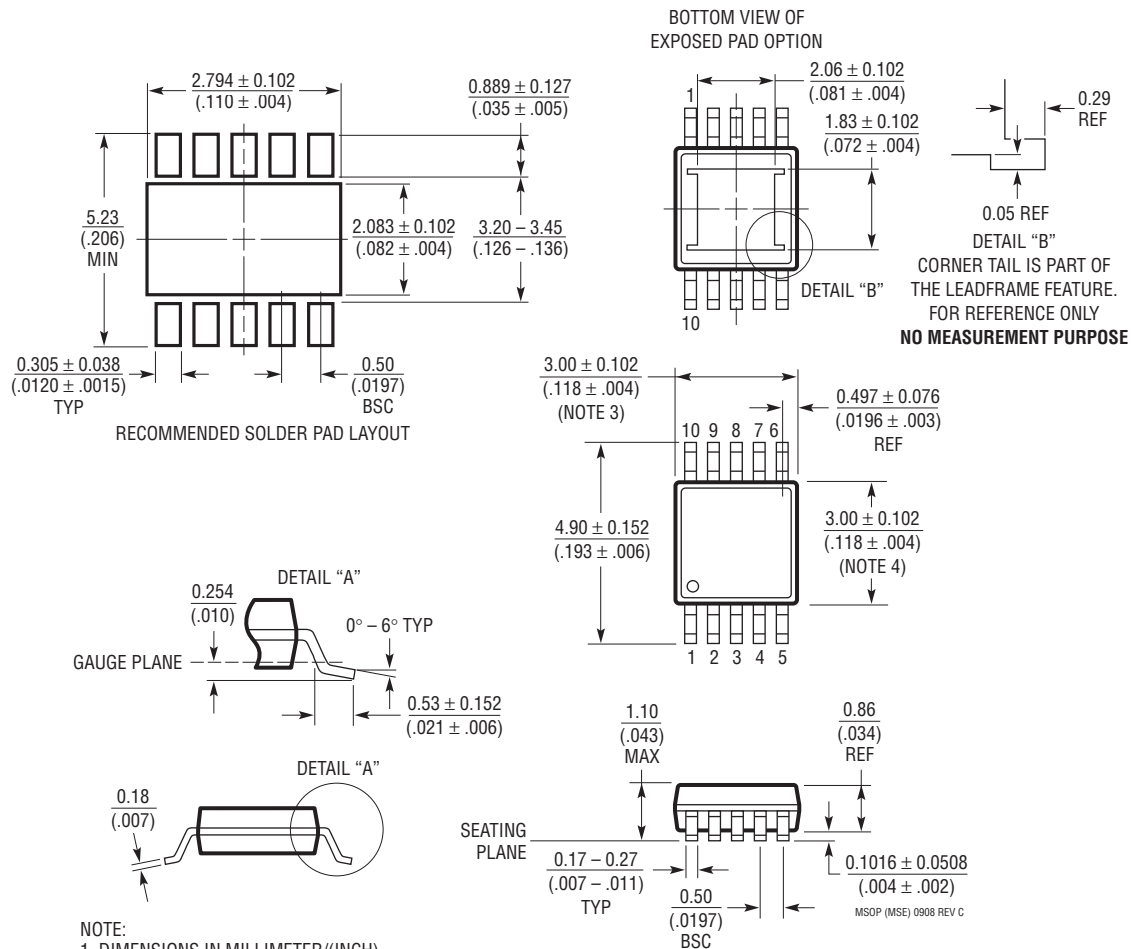

- NOTE:
1. DIMENSIONS IN MILLIMETER/(INCH)
  2. DRAWING NOT TO SCALE
  3. DIMENSION DOES NOT INCLUDE MOLD FLASH, PROTRUSIONS OR GATE BURRS.  
MOLD FLASH, PROTRUSIONS OR GATE BURRS SHALL NOT EXCEED 0.152mm (.006") PER SIDE
  4. DIMENSION DOES NOT INCLUDE INTERLEAD FLASH OR PROTRUSIONS.  
INTERLEAD FLASH OR PROTRUSIONS SHALL NOT EXCEED 0.152mm (.006") PER SIDE
  5. LEAD COPLANARITY (BOTTOM OF LEADS AFTER FORMING) SHALL BE 0.102mm (.004") MAX

MSOP (MSE) 0908 REV C

## TYPICAL APPLICATION

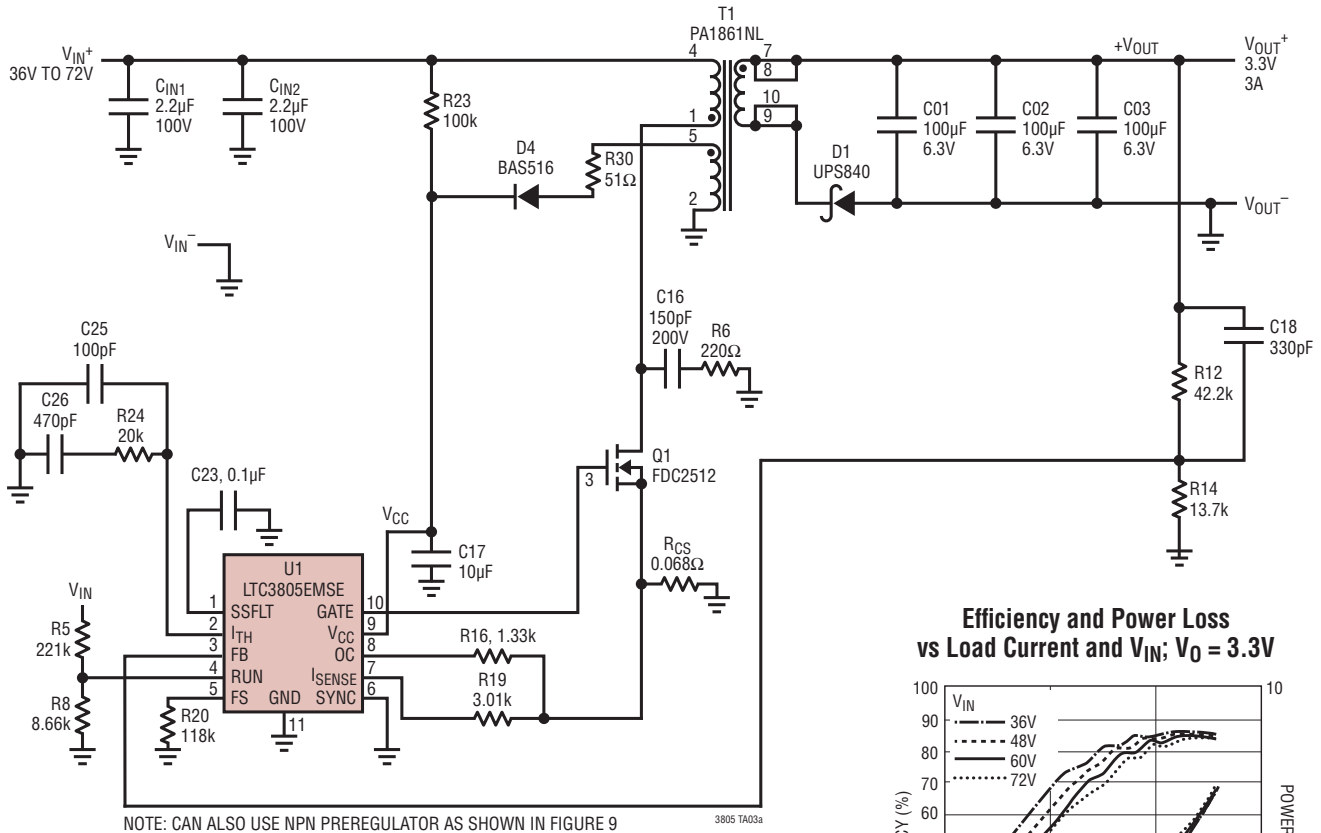
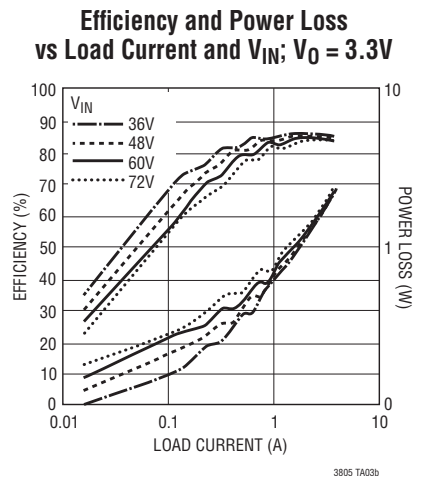

Figure 10. Low Power Nonisolated Telecom Supply with Trickle Charger



## RELATED PARTS

PART NUMBER	DESCRIPTION	COMMENTS
LT1725	General Purpose High Power Isolated Flyback Controller	Suitable for Telecom 36V to 75V Inputs
LTC1871	Wide Input Range, No $R_{SENSE}^{\text{TM}}$ Current Mode Boost, Flyback and SEPIC Controller	Constant-Frequency Current Mode Flyback DC/DC Controller in ThinSOT <sup>TM</sup>
LT1950	Single Switch PWM Controller with Auxiliary Boost Converter	Single Switch PWM Controller with Auxiliary Boost Converter
LT1952	Single Switch Synchronous Forward Controller	Single Switch Synchronous Forward Controller
LTC3803	Constant-Frequency Current Mode Flyback DC/DC Controller in ThinSOT	Wide Input Range, Current Mode Boost, Flyback and SEPIC Controller
LT3825	Isolated No-OPTO Synchronous Flyback Controller with Wide Input Supply Range	Input Voltage Limited Only by External Components

No  $R_{SENSE}$  and ThinSOT are Trademarks of Linear Technology Corporation.