

## Features

- Formerly *J.W. Miller* model
- 1008 size
- Available in E12 series
- High Q up to 60 typ.
- High operating temperature of 125 °C
- RoHS compliant\*

## Applications

- Mobile phones
- Cellular phones
- CTV, VCR, HIC, FDD

**BOURNS®**

# PM1008 Series - High Q Chip Inductors

### Electrical Specifications

Bourns Part No.	Inductance		Q Min.	Test Frequency (MHz)		SRF Min. (MHz)	RDC (Ω)	I rms Max. (mA)
	nH	Tol. %		L	Q			
PM1008-10NM-RC	10	±20	50	100	500	4100	0.08	600
PM1008-12NM-RC	12	±20	50	100	500	3300	0.08	600
PM1008-15NM-RC	15	±20	40	100	350	2500	0.08	500
PM1008-18NM-RC	18	±20	50	100	350	2500	0.10	600
PM1008-22NM-RC	22	±20	55	100	350	2400	0.10	600
PM1008-27NM-RC	27	±20	55	100	350	1600	0.10	600
PM1008-33NM-RC	33	±20	60	100	350	1600	0.10	600
PM1008-39NM-RC	39	±20	60	100	350	1500	0.10	600
PM1008-47NM-RC	47	±20	60	100	350	1500	0.10	600
PM1008-56NK-RC	56	±10	60	100	350	1300	0.12	600
PM1008-68NK-RC	68	±10	60	100	350	1300	0.15	600
PM1008-82NK-RC	82	±10	60	100	350	1000	0.18	600
PM1008-R10K-RC	100	±10	60	100	350	1000	0.18	500
PM1008-R12K-RC	120	±10	50	25	100	950	0.20	500
PM1008-R15K-RC	150	±10	45	25	100	850	0.22	500
PM1008-R18K-RC	180	±10	45	25	100	750	0.33	500
PM1008-R22K-RC	220	±10	45	25	100	700	0.45	500
PM1008-R27K-RC	270	±10	45	25	100	600	0.75	500
PM1008-R33K-RC	330	±10	45	25	100	570	0.90	500
PM1008-R39K-RC	390	±10	45	25	100	500	1.20	400
PM1008-R47K-RC	470	±10	45	25	100	450	1.19	470
PM1008-R56K-RC	560	±10	45	25	100	415	1.33	400
PM1008-R68K-RC	680	±10	45	25	100	375	1.47	400
PM1008-R82K-RC	820	±10	45	25	100	350	1.61	360
PM1008-1R0K-RC	1000	±10	25	25	50	290	1.75	330
PM1008-1R2K-RC	1200	±10	25	7.9	7.9	250	2.00	280
PM1008-1R5K-RC	1500	±10	25	7.9	7.9	200	2.30	280
PM1008-1R8K-RC	1800	±10	25	7.9	7.9	160	2.60	270
PM1008-2R2K-RC	2200	±10	25	7.9	7.9	160	2.80	250
PM1008-2R7K-RC	2700	±10	22	7.9	7.9	70	1.70	195
PM1008-3R3K-RC	3300	±10	22	7.9	7.9	55	1.90	185
PM1008-3R9K-RC	3900	±10	20	7.9	7.9	48	2.10	180
PM1008-4R7K-RC	4700	±10	18	7.9	7.9	43	2.30	175
PM1008-5R6K-RC	5600	±10	18	7.9	7.9	40	4.90	180
PM1008-6R8K-RC	6800	±10	18	7.9	7.9	25	6.00	150
PM1008-8R2K-RC	8200	±10	18	7.9	7.9	25	8.00	100
PM1008-100K-RC	10000	±10	18	2.5	7.9	40	4.20	200

### Packaging Specifications

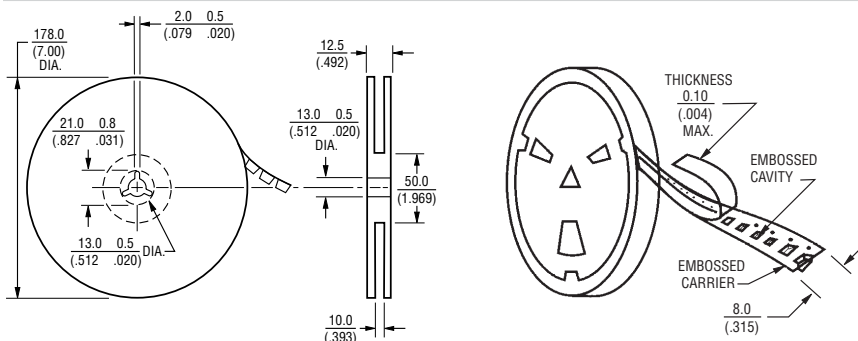

\*RoHS Directive 2002/95/EC Jan 27, 2003 including Annex.

Specifications are subject to change without notice.

Customers should verify actual device performance in their specific applications

### General Specifications

Temperature Rise  
 ..... 40 °C max. at rated current  
 Operating Temperature  
 ..... -40 °C to +125 °C  
 Storage Temperature  
 ..... -40 °C to +125 °C  
 Reflow Soldering .. 230 °C, 50 sec. max.  
 Resistance to Soldering Heat  
 ..... 260 °C, 5 seconds

### Materials

Core Material  
 -10NM thru -R82K ..... Ceramic  
 -1R0K thru -100K ..... Ferrite  
 Wire ..... Enamelled Copper (1W1E180)  
 Terminal ..... Mo/Mn+Ni+Au  
 Packaging ..... 2,000 pcs per reel

### Product Dimensions

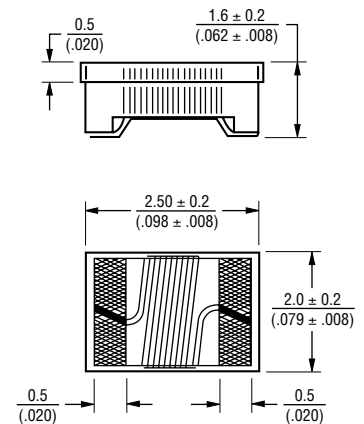

### Recommended Layout

