

SMT Common Mode Chokes

Special Features

- Reduce conductive EMI emission
- Wide frequency range 10K to 100MHz
- High current capacity
- Compact size
- Coil encapsulated in high-strength plastic case
- Suitable for wave & reflow solder
- Dielectric withstanding voltage 500VRMS
- Operating temperature -55 to +105
- Tape & reel packaged 200/reel

PM3700 Series				
Part Number	L (mH) Min.	DCR (Ω) Max.	I* (A)	Typ. Freq. Range with 20dB Atten.
PM3700-10	0.2	0.008	7.0	5 - 55 MHz
PM3700-20	0.5	0.01	6.0	4 - 40 MHz
PM3700-30	0.75	0.012	5.5	1 - 20 MHz
PM3700-40	1.0	0.02	4.0	500 KHz - 40 MHz
PM3700-50	2.0	0.03	3.5	300 KHz - 20 MHz
PM3700-60	5.0	0.07	2.0	100 KHz - 10 MHz
PM3700-70	10	0.15	1.5	50 KHz - 5 MHz
PM3700-80	20	0.25	1.0	25 KHz - 4 MHz

Also available as RoHS compliant.

Notes

* Current to cause 35°C maximum temperature rise

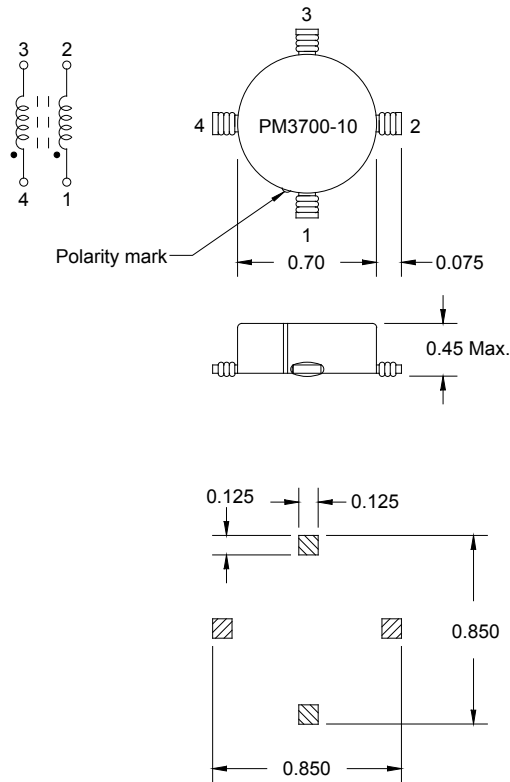

Dimensions: Inches

Pad Layout

J.W. Miller
MAGNETICS

306 E. Alondra Blvd. Gardena, CA 90247-1059 • Phone (310) 515-1720 • FAX (310) 515-1962

www.jwmiller.com