

ASMT-Mx04

High Brightness Moonstone® 1W Power LED Light Source



Data Sheet



Description

The High Brightness Moonstone® 1W Power LED Light Source is a high performance energy efficient device which can handle high thermal and high driving current. The exposed pad design has excellent heat transfer from the package to the motherboard.

The low profile package design is suitable for a wide variety of applications especially where height is a constraint.

The package is compatible with reflow soldering. This will give more freedom and flexibility to the light source designer.

The 1W Power LED light source can be mounted onto metal core PCB enabling optimum heat dissipation and ease of installation.

Specifications

- InGaN Technology
- 3.5 V (max) at 350 mA
- 110° viewing angle

Features

- Available in Cool White & Warm White color
- Energy efficient
- Exposed pad for excellent heat transfer
- Suitable for reflow soldering process
- High current operation
- Long operation life
- Wide viewing angle
- Silicone encapsulation
- Non-ESD sensitive (threshold > 16KV)
- MSL 2a products

Applications

- Sign backlight, billboard illumination or backlight
- Exit sign or emergency sign lightings
- Commercial lightings
- Accent and marker lightings
- Pathway lighting
- Task lighting
- Reading lights
- Decorative lighting
- Garden lighting
- Architectural lighting
- Portable (flash light, bicycle head light)

Device Selection Guide ($T_j = 25^\circ\text{C}$)

Part Number	Color	Luminous Flux, Φ_V [1,2] (lm)			Test Current (mA)	Dice Technology	Electrically Isolated Metal Slug
		Min.	Typ.	Max.			
ASMT-MW04-NMN00	Cool White	95.0	110.0	125.0	350	InGaN	Yes
ASMT-MY04-NLM00	Warm White	73.0	95.0	110.0	350	InGaN	Yes

Notes:

- Φ_V is the total luminous flux output as measured with an integrating sphere at 25ms mono pulse condition.
- Flux tolerance is $\pm 10\%$.

Absolute Maximum Ratings ($T_A = 25^\circ\text{C}$)

Parameter	ASMT-Mx04	Units
DC Forward Current [4]	350	mA
Peak Pulsing Current [5]	1000	mA
Power Dissipation	1225	mW
LED Junction Temperature	125	$^\circ\text{C}$
Operating Ambient Temperature Range	-40 to +110	$^\circ\text{C}$
Storage Temperature Range	-40 to +120	$^\circ\text{C}$
Soldering Temperature	Refer to Figure 13	
Reverse Voltage [6]	Not recommended	

Notes:

- Derate linearly based on Figure 11.
- Pulse condition duty factor = 10%, Frequency = 1kHz.
- Not recommended for reverse bias operation.

Optical Characteristics at 350 mA ($T_j = 25^\circ\text{C}$)

Part Number	Color	Correlated Color Temperature, CCT (Kelvin)		Viewing Angle, $2\theta_{1/2}$ [7] ($^\circ$)	Luminous Efficiency (lm/W)
		Min.	Max.		
ASMT-MW04-NMN00	Cool White	4000	10000	110	98
ASMT-MY04-NLM00	Warm White	2600	4000	110	85

Notes:

- $\theta_{1/2}$ is the off-axis angle where the luminous intensity is $1/2$ the peak intensity.

Electrical Characteristic at 350 mA ($T_j = 25^\circ\text{C}$)

Dice type	Forward Voltage V_F (Volts) at $I_F = 350\text{mA}$			Thermal Resistance $R\theta_{j-ms}$ ($^\circ\text{C/W}$) [8]
	Min.	Typ.	Max.	Typ.
InGaN	2.8	3.2	3.5	10

Note:

- $R\theta_{j-ms}$ is the Thermal Resistance from LED junction to metal slug.

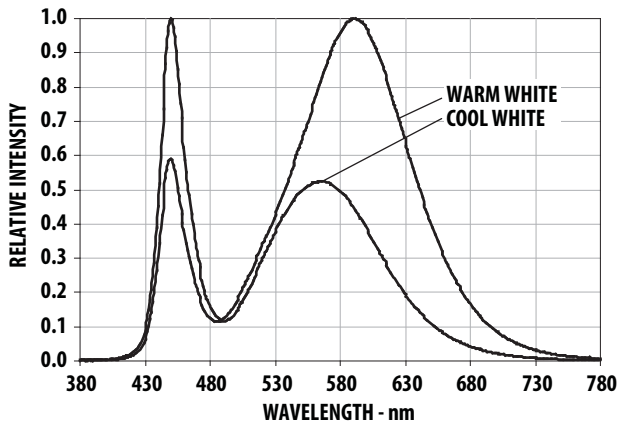

Figure 4. Relative Intensity vs. Wavelength.

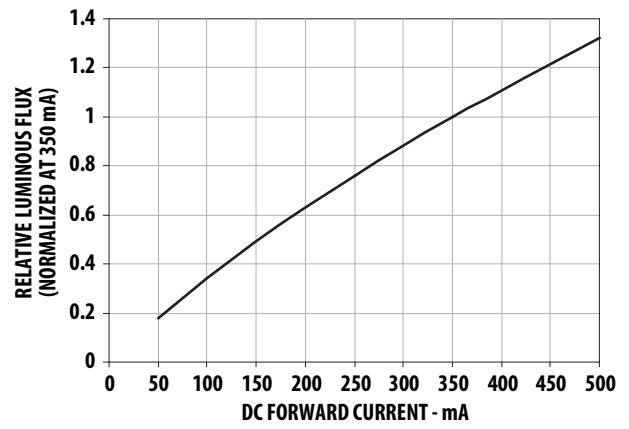

Figure 5. Relative Luminous Flux vs. Mono Pulse Current.

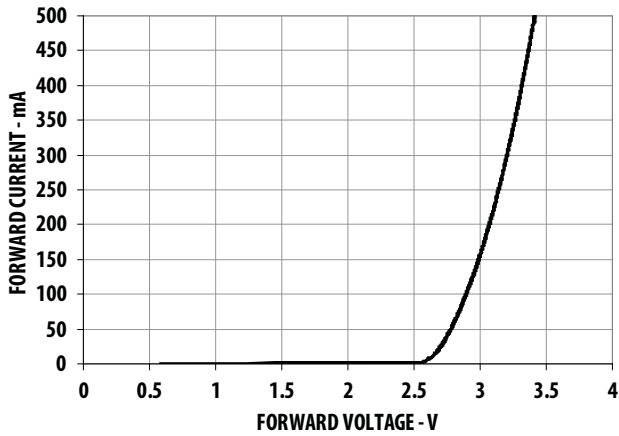

Figure 6. Forward Current vs. Forward Voltage.

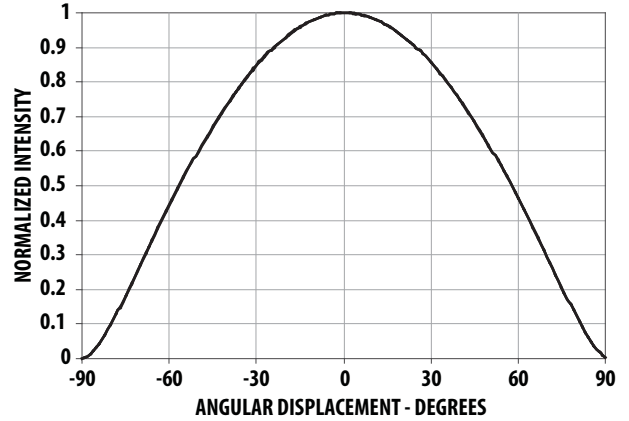

Figure 7. Radiation Pattern.

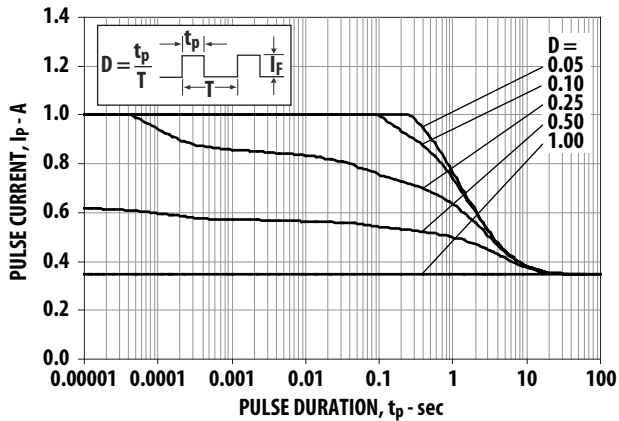

Figure 8. Maximum pulse current vs. ambient temperature. Derated based on $T_A = 25^\circ\text{C}$, $R\theta_{J-A} = 50^\circ\text{C/W}$.

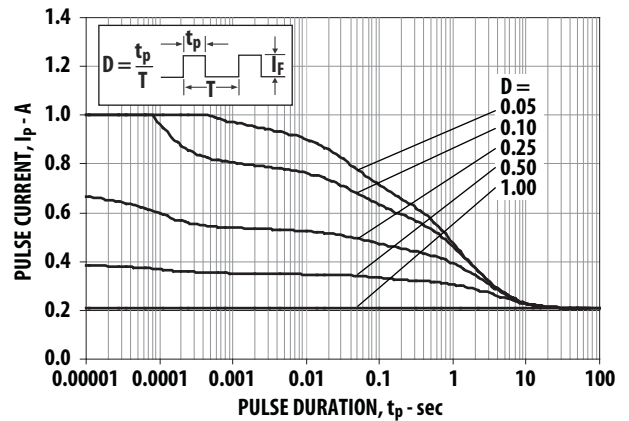

Figure 9. Maximum pulse current vs. ambient temperature. Derated based on $T_A = 85^\circ\text{C}$, $R\theta_{J-A} = 50^\circ\text{C/W}$.

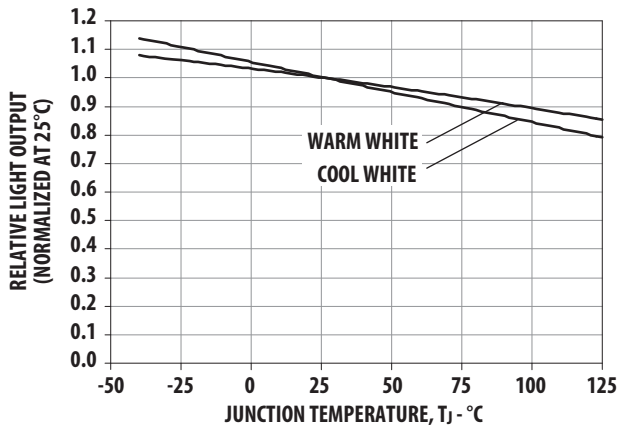

Figure 10. Relative Light Output vs. Junction Temperature.

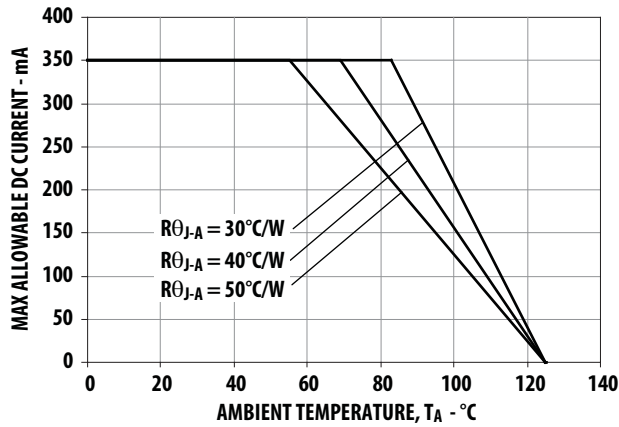

Figure 11. Maximum Forward Current vs. Ambient Temperature. Derated based on $T_{JMAX} = 125^{\circ}C$, $R_{\theta J-A} = 30^{\circ}C/W$, $40^{\circ}C/W$ and $50^{\circ}C/W$.

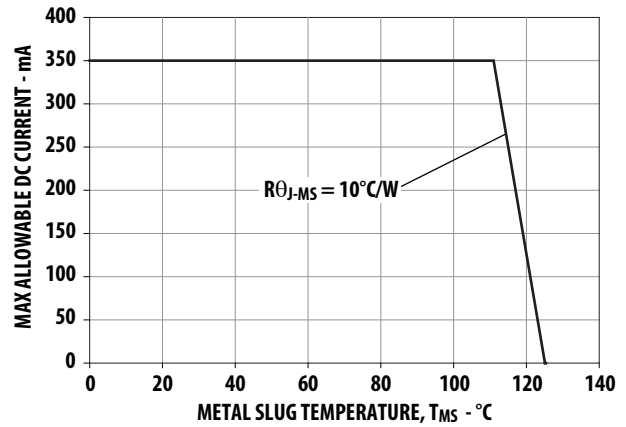

Figure 12. Maximum Forward Current vs. Metal Slug Temperature. Derated based on $T_{JMAX} = 125^{\circ}C$, $R_{\theta J-MS} = 10^{\circ}C/W$.

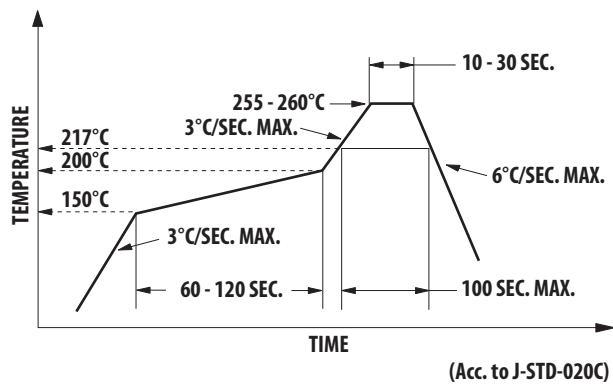

Figure 13. Recommended Reflow Soldering.

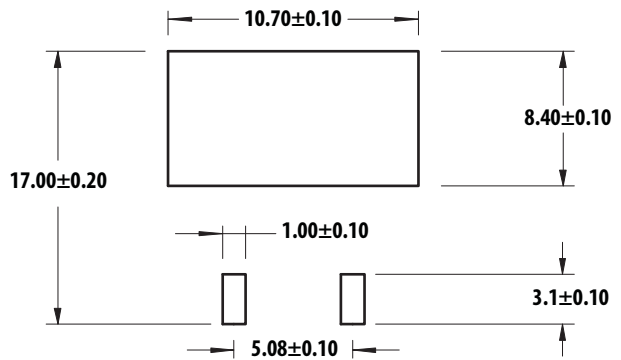

Figure 14. Recommended soldering land pattern.

Note:

For detail information on reflow soldering of Avago surface mount LEDs, do refer to Avago Application Note AN1060 Surface Mounting SMT LED Indicator Components.

Option Selection Details

ASMT-Mx₁ x₂ 4 - N x₃ x₄ x₅ x₆

x₃ – Minimum Flux Bin

x₄ – Maximum Flux Bin

x₅ – Color Bin Selection

x₆ – Packaging Option

Color Bin Selections [x₅]

Individual reel will contain parts from one full bin only.

Cool White

0	Full Distribution
A	A only
B	B only
C	C only
D	D only
E	E only
F	F only
G	G only
H	H only
L	A and G only
M	B and H only
N	A and C only
P	B and D only
Q	E and C only
R	F and D only
S	G and H only
U	E and F only
W	C and D only
Z	A and B only
1	A, B, C and D only
2	G, H, A and B only
4	C, D, E and F only

Flux Bin Limit [x₃, x₄]

Bin	Luminous Flux (lm) at I_F = 350mA	
	Min.	Max.
K	56.0	73.0
L	73.0	95.0
M	95.0	110.0
N	110.0	125.0

Tolerance for each bin limits is ±10%.

Warm White

0	Full Distribution
A	A only
B	B only
C	C only
D	D only
E	E only
F	F only
N	A and C only
P	B and D only
Q	E and C only
R	F and D only
U	E and F only
W	C and D only
Z	A and B only
1	A, B, C and D only
4	C, D, E and F only

Color Bin Limit

Cool White	Color Limits (Chromaticity Coordinates)				
		X	Y	X	Y
Bin A	X	0.367	0.362	0.329	0.329
	Y	0.400	0.372	0.345	0.369
Bin B	X	0.362	0.356	0.329	0.329
	Y	0.372	0.330	0.302	0.345
Bin C	X	0.329	0.329	0.305	0.301
	Y	0.369	0.345	0.322	0.342
Bin D	X	0.329	0.329	0.311	0.305
	Y	0.345	0.302	0.285	0.322
Bin E	X	0.303	0.307	0.283	0.274
	Y	0.333	0.311	0.284	0.301
Bin F	X	0.307	0.311	0.290	0.283
	Y	0.311	0.285	0.265	0.284
Bin G	X	0.388	0.379	0.362	0.367
	Y	0.417	0.383	0.372	0.400
Bin H	X	0.379	0.369	0.356	0.362
	Y	0.383	0.343	0.330	0.372

Tolerance: ± 0.01

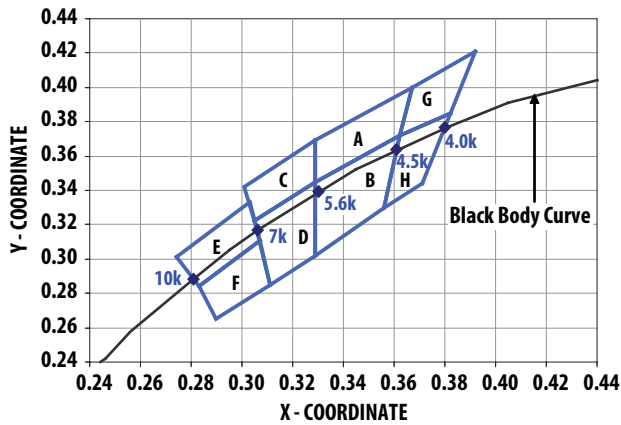

Figure 15. Color bins (Cool White).

Packaging Option [x₆]

Selection	Option
0	Tube (for Moonstone® only)
1	Tape and Reel

Warm White	Color Limits (Chromaticity Coordinates)				
		X	Y	X	Y
Bin A	X	0.452	0.488	0.470	0.438
	Y	0.434	0.447	0.414	0.403
Bin B	X	0.438	0.470	0.452	0.424
	Y	0.403	0.414	0.384	0.376
Bin C	X	0.407	0.418	0.452	0.438
	Y	0.393	0.422	0.434	0.403
Bin D	X	0.395	0.407	0.438	0.424
	Y	0.362	0.393	0.403	0.376
Bin E	X	0.381	0.387	0.418	0.407
	Y	0.377	0.404	0.422	0.393
Bin F	X	0.373	0.381	0.407	0.395
	Y	0.349	0.377	0.393	0.362

Tolerance: ± 0.01

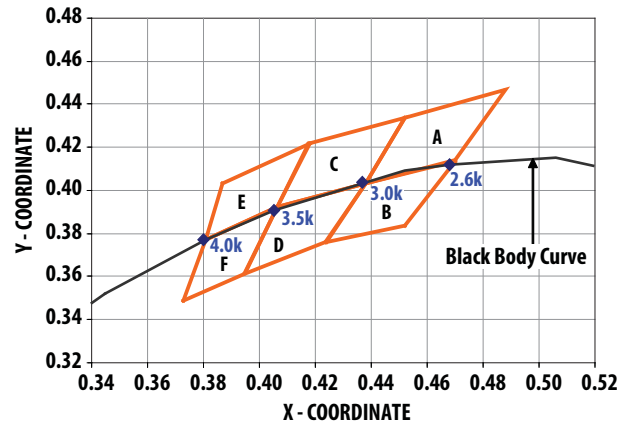

Figure 16. Color bins (Warm White).

Example

ASMT-MW04-NKLZ1

ASMT-MW04-Nxxxx – Cool White, Non-diffused

- X₃ = M – Minimum Flux Bin M
- X₄ = N – Maximum Flux Bin N
- X₅ = Z – Color Bin A and B only
- X₆ = 1 – Tape and Reel Option

Packing Tube – Option 0

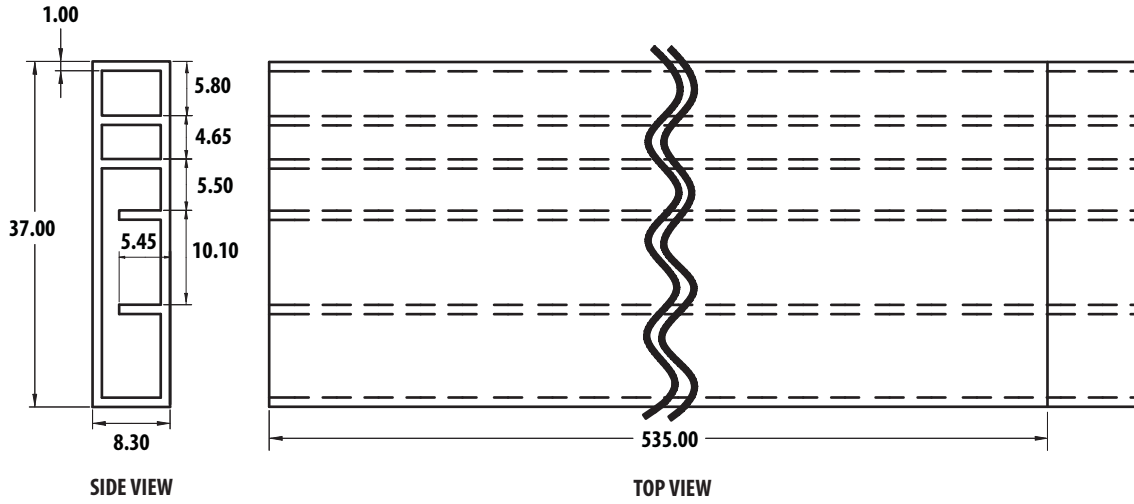

Figure 17. Tube dimensions.

Tape and Reel – Option 1

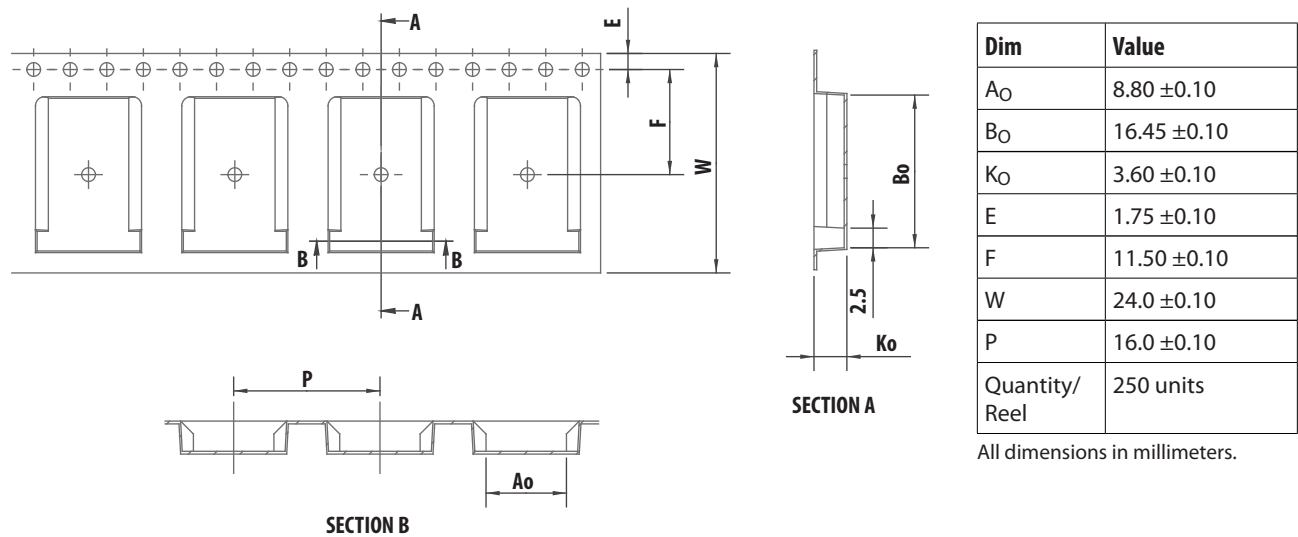

Figure 18. Carrier tape dimensions.

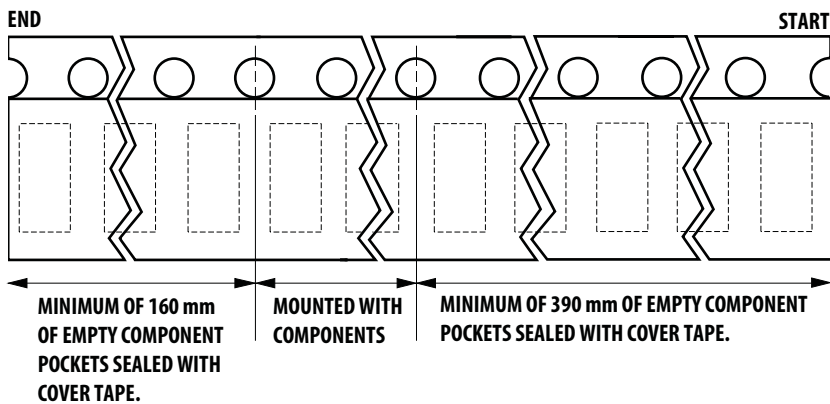

Figure 19. Carrier tape leader and trailer dimensions.

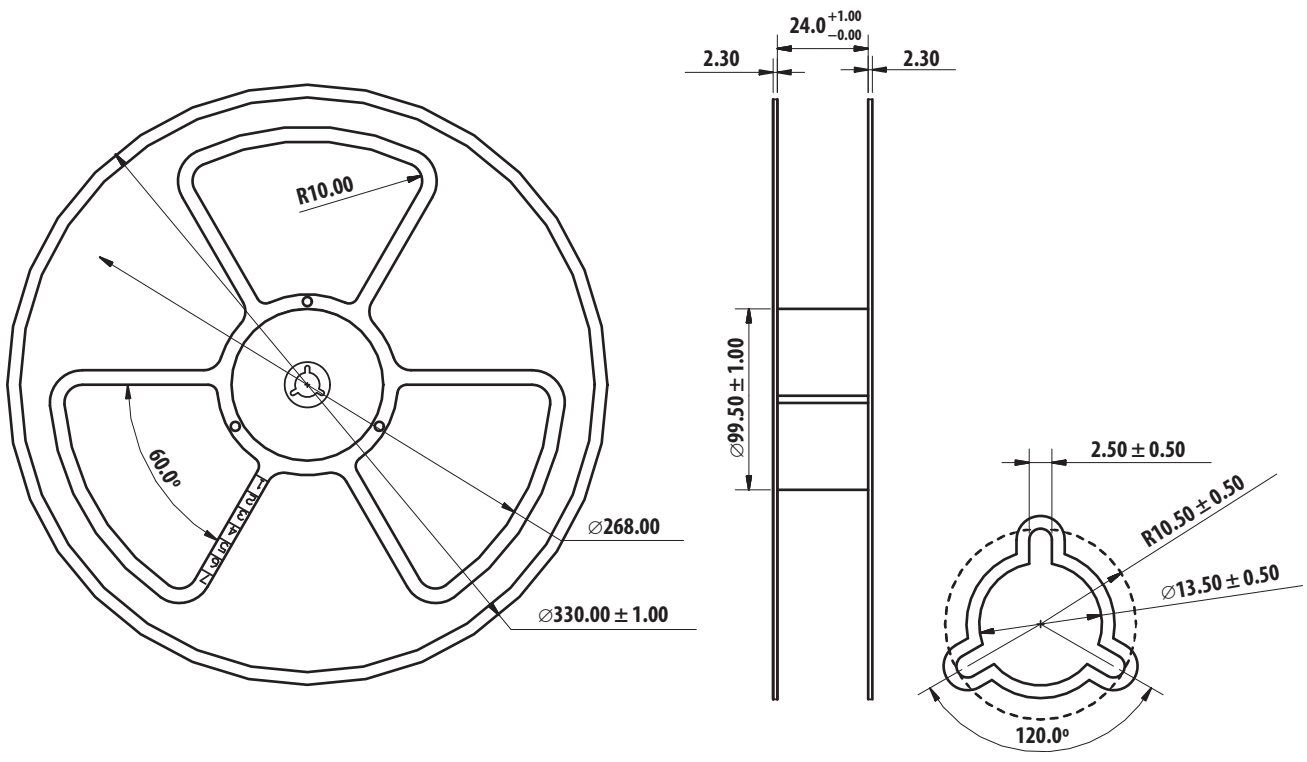

Figure 20. Reel dimensions.

Handling Precaution

The encapsulation material of the product is made of silicone for better reliability of the product. As silicone is a soft material, please do not press on the silicone or poke a sharp object onto the silicone. These might damage the product and cause premature failure. During assembly of handling, the unit should be held on the body only. Please refer to Avago Application Note AN 5288 for detail information.

Moisture Sensitivity

This product is qualified as Moisture Sensitive Level 2a per Jedec J-STD-020. Precautions when handling this moisture sensitive product is important to ensure the reliability of the product. Do refer to Avago Application Note AN5305 Handling of Moisture Sensitive Surface Mount Devices for details.

A. Storage before use

- Unopen moisture barrier bag (MBB) can be stored at $40^{\circ}\text{C}/90\% \text{RH}$ for 12 months. If the actual shelf life has exceeded 12 months and the humidity indicator card (HIC) indicates that baking is not required, then it is safe to reflow the LEDs per the original MSL rating.
- It is not recommended to open the MBB prior to assembly (e.g. for IQC).

B. Control after opening the MBB

- The humidity indicator card (HIC) shall be read immediately upon opening of MBB.
- The LEDs must be kept at $30^{\circ}\text{C} / 60\% \text{RH}$ at all time and all high temperature related process including soldering, curing or rework need to be completed within 672 hours.

C. Control for unfinished reel

- For any unused LEDs, they need to be stored in sealed MBB with desiccant or desiccator at $5\% \text{RH}$.

D. Control of assembly boards

- If the PCB soldered with the LEDs is to be subjected to other high temperature processes, the PCB need to be stored in sealed MBB with desiccant or desiccator at $5\% \text{RH}$ to ensure no LEDs have exceeded their floor life of 672 hours.

E. Baking is required if

- HIC "10%" indicator is not blue and "5%" indicator is pink.
- The LEDs are exposed to condition of $30^{\circ}\text{C} / 60\% \text{RH}$ at any time.
- The LED floor life exceeded 672hrs.

Recommended baking condition: $60 \pm 5^{\circ}\text{C}$ for 20hrs.

DISCLAIMER: Avago's products and software are not specifically designed, manufactured or authorized for sale as parts, components or assemblies for the planning, construction, maintenance or direct operation of a nuclear facility or for use in medical devices or applications. Customer is solely responsible, and waives all rights to make claims against Avago or its suppliers, for all loss, damage, expense or liability in connection with such use.

For product information and a complete list of distributors, please go to our web site: www.avagotech.com

Avago, Avago Technologies, and the A logo are trademarks of Avago Technologies in the United States and other countries. Data subject to change. Copyright © 2005-2012 Avago Technologies. All rights reserved. AV02-3405EN - March 8, 2012

AVAGO
TECHNOLOGIES