

Distributed by:

JAMECO[®]
ELECTRONICS

www.Jameco.com ♦ 1-800-831-4242

The content and copyrights of the attached
material are the property of its owner.

Jameco Part Number 1552430

For the HEDS-9100, standard resolutions between 96 CPR and 512 CPR are available for use with a HEDS-5120 codewheel or equivalent.

Applications

The HEDS-9000 and 9100 provide sophisticated motion detection at a low cost, making them ideal for high volume applications. Typical applications include printers, plotters, tape drives, and factory automation equipment.

Note: Avago Technologies encoders are not recommended for use in safety critical applications. Eg. ABS braking systems, power steering, life support systems and critical care medical equipment. Please contact sales representative if more clarification is needed.

Theory of Operation

The HEDS-9000 and 9100 are C-shaped emitter/detector modules. Coupled with a codewheel, they translate the rotary motion of a shaft into a two-channel digital output.

As seen in the block diagram, each module contains a single Light Emitting Diode (LED) as its light source. The light is collimated into a parallel beam by means of a single polycarbonate lens located directly over the LED. Opposite the emitter is the integrated detector circuit. This IC consists of multiple sets of photodetectors and the signal processing circuitry necessary to produce the digital waveforms.

The codewheel rotates between the emitter and detector, causing the light beam to be interrupted

Block Diagram

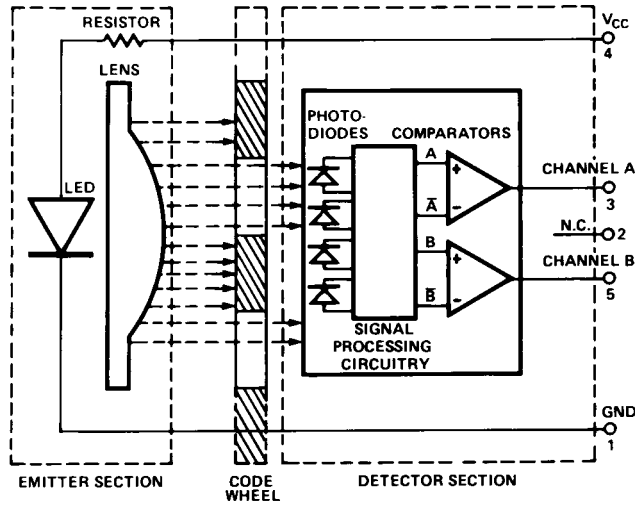

Output Waveforms

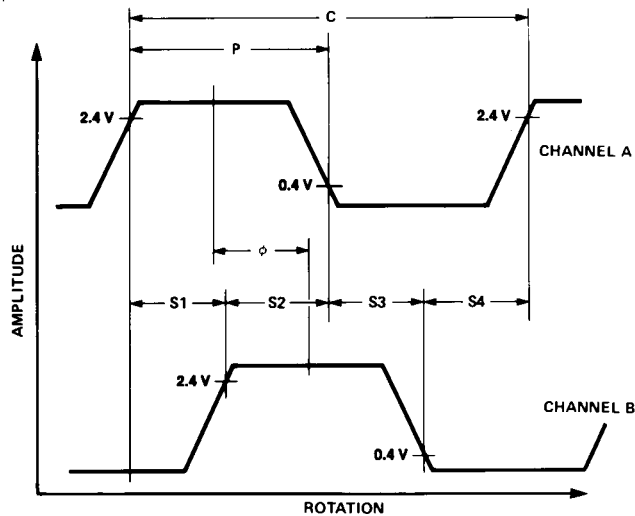

by the pattern of spaces and bars on the codewheel. The photodiodes which detect these interruptions are arranged in a pattern that corresponds to the radius and design of the code wheel. These detectors are also spaced such that a light period on one pair of detectors corresponds to a dark period on the adjacent pair of detectors. The photodiode

outputs are then fed through the signal processing circuitry resulting in A , \bar{A} , B , and \bar{B} . Two comparators receive these signals and produce the final outputs for channels A and B. Due to this integrated phasing technique, the digital output of channel A is in quadrature with that of channel B (90 degrees out of phase).

Definitions

Count (N): The number of bar and window pairs or counts per revolution (CPR) of the codewheel.

1 Shaft Rotation = 360
mechanical
degrees,
= N cycles.

1 cycle (C) = 360
electrical
degrees (°e),
= 1 bar and
window pair.

Pulse Width (P): The number of electrical degrees that an output is high during 1 cycle. This value is nominally 180°e or 1/2 cycle.

Pulse Width Error (ΔP): The deviation, in electrical degrees of the pulse width from its ideal value of 180°e.

State Width (S): The number of electrical degrees between a

Absolute Maximum Ratings

Storage Temperature, T_S -40°C to 100°C
Operating Temperature, T_A -40°C to 100°C
Supply Voltage, V_{CC} -0.5 V to 7 V
Output Voltage, V_O -0.5 V to V_{CC}
Output Current per Channel, I_{out} -1.0 mA to 5 mA

transition in the output of channel A and the neighboring transition in the output of channel B. There are 4 states per cycle, each nominally 90°e.

State Width Error (ΔS): The deviation, in electrical degrees, of each state width from its ideal value of 90°e.

Phase (φ): The number of electrical degrees between the center of the high state of channel A and the center of the high state of channel B. This value is nominally 90°e for quadrature output.

Phase Error (Δφ): The deviation of the phase from its ideal value of 90°e.

Direction of Rotation: When the codewheel rotates in the direction of the arrow on top of the module, channel A will lead channel B. If the codewheel rotates in the opposite direction, channel B will lead channel A.

Optical Radius (R_{op}): The distance from the codewheel's center of rotation to the optical center (O.C.) of the encoder module.

Recommended Operating Conditions

Parameter	Symbol	Min.	Typ.	Max.	Units	Notes
Temperature	T	-40		100	°C	
Supply Voltage	V_{CC}	4.5		5.5	Volts	Ripple < 100 mV _{p-p}
Load Capacitance	C_L			100	pF	3.3 kΩ pull-up resistor
Count Frequency	f			100	kHz	$\frac{\text{Velocity (rpm)} \times N}{60}$

Note: The module performance is guaranteed to 100 kHz but can operate at higher frequencies.

Encoding Characteristics

Encoding Characteristics over Recommended Operating Range and Recommended Mounting Tolerances. These Characteristics do not include codewheel/codestrip contribution.

Description	Sym.	Typ.	Case 1 Max.	Case 2 Max.	Units	Notes
Pulse Width Error	ΔP	30	40		°e	
Logic State Width Error	ΔS	30	40		°e	
Phase Error	Δφ	2	10	105	°e	

Case 1: Module mounted on tolerance circle of ± 0.13 mm (± 0.005 in.).

Case 2: HEDS-9000 mounted on tolerances of ± 0.50 mm (0.020").

HEDS-9100 mounted on tolerances of ± 0.38 mm (0.015").

Electrical Characteristics

Electrical Characteristics over Recommended Operating Range, typical at 25°C.

Parameter	Symbol	Min.	Typical	Max.	Units	Notes
Supply Current	I_{CC}		17	40	mA	
High Level Output Voltage	V_{OH}	2.4			Volts	$I_{OH} = -40 \mu\text{A max.}$
Low Level Output Voltage	V_{OL}			0.4	Volts	$I_{OL} = 3.2 \text{ mA}$
Rise Time	t_r		200		ns	$C_L = 25 \text{ pF}$ $R_L = 11 \text{ k}\Omega \text{ pull-up}$
Fall Time	t_f		50		ns	

Derating Curves over Extended Operating Frequencies (HEDS-9000/9100)

Below are the derating curves for state, duty, phase and V_{OH} over extended operating frequencies of up to 240 kHz (recommended maximum frequency is 100 kHz). The curves were derived using standard TTL load. -40°C operation is not feasible above 160 kHz because V_{OH} will drop below 2.4 V (the minimum TTL for logic state high) beyond that frequency.

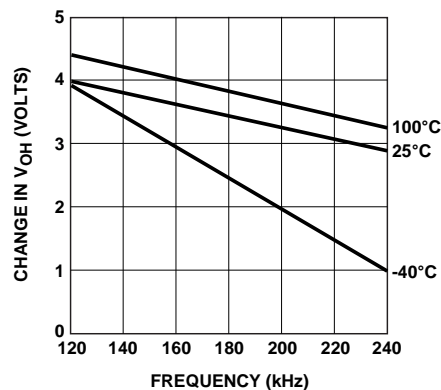
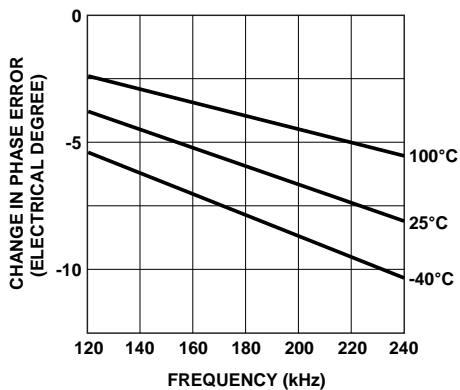
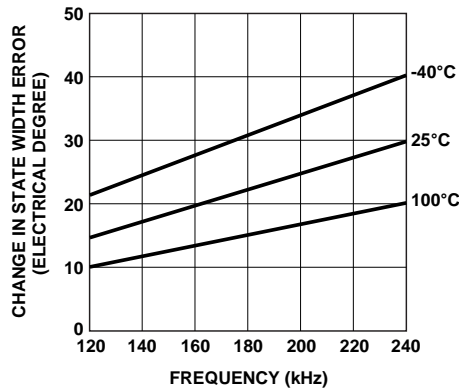
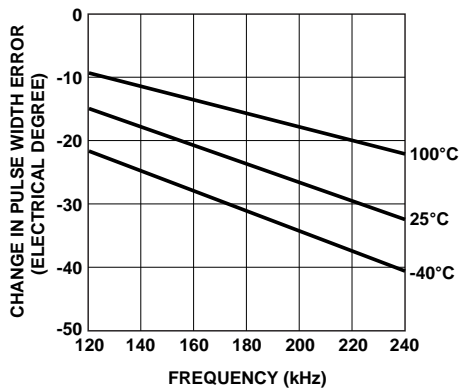

Recommended Codewheel Characteristics

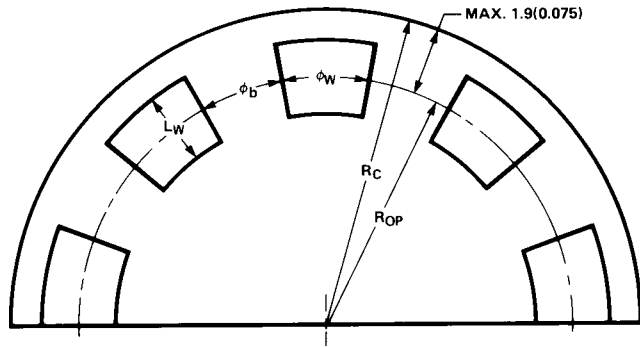

Figure 1. Codestrip Design

Codewheel Options

HEDS Series	CPR (N)	Option	Optical Radius mm (in.)
5120	96	K	11.00 (0.433)
5120	100	C	11.00 (0.433)
5120	192	D	11.00 (0.433)
5120	200	E	11.00 (0.433)
5120	256	F	11.00 (0.433)
5120	360	G	11.00 (0.433)
5120	400	H	11.00 (0.433)
5120	500	A	11.00 (0.433)
5120	512	I	11.00 (0.433)
6100	500	A	23.36 (0.920)
6100	1000	B	23.36 (0.920)

Parameter	Symbol	Minimum	Maximum	Units	Notes
Window/Bar Ratio	ϕ_W/ϕ_b	0.7	1.4		
Window Length	L_W	1.8 (0.071)	2.3 (0.09)	mm (inch)	
Absolute Maximum Codewheel Radius	R_C		$R_{OP} + 1.9$ (0.0075)	mm (inch)	Includes eccentricity errors

Mounting Considerations

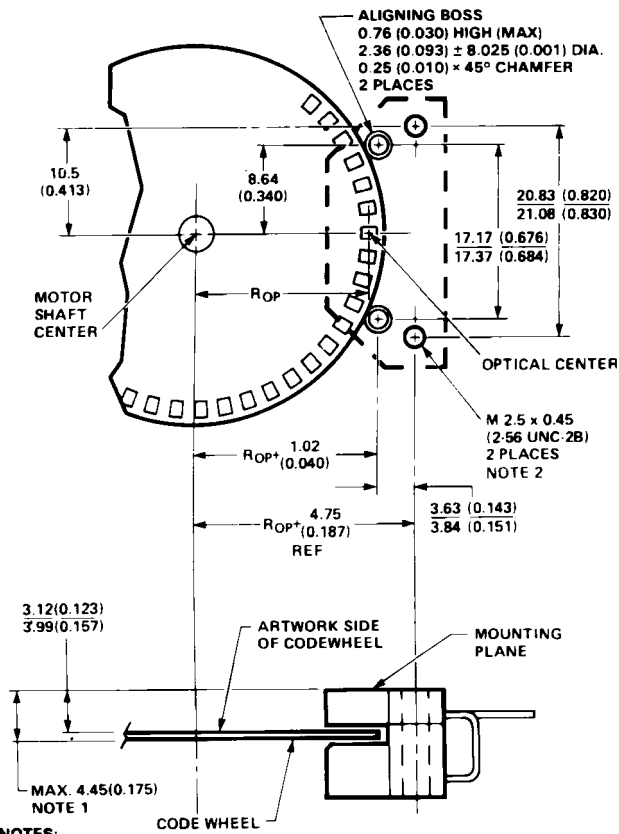

NOTES:
 1. THESE DIMENSIONS INCLUDE SHAFT END PLAY, AND CODEWHEEL WARP.
 2. MAXIMUM RECOMMENDED MOUNTING SCREW TORQUE IS 4 kg-cm (3.5 in-lbs).

Figure 2. Mounting Plane Side A.

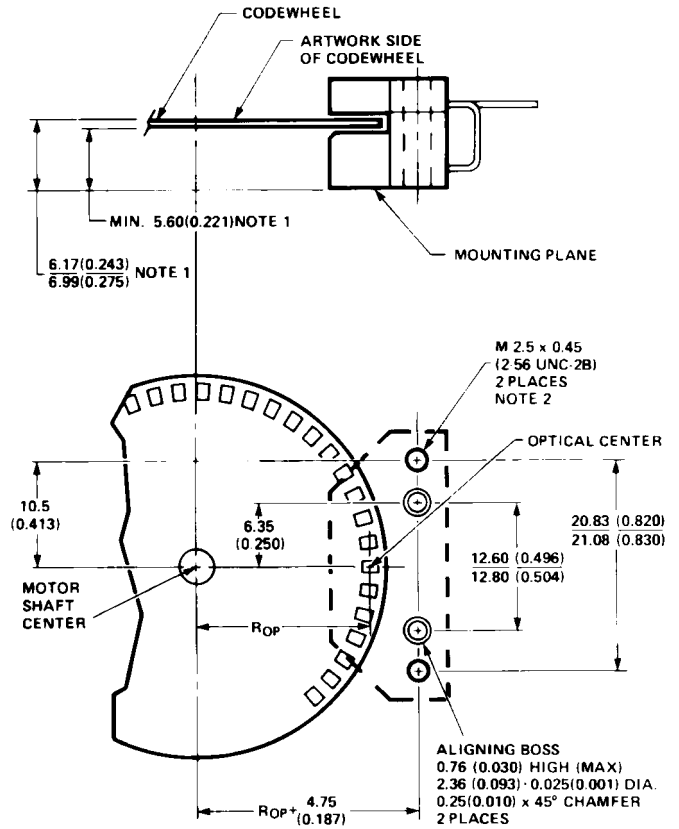

NOTES:
 1. THESE DIMENSIONS INCLUDE SHAFT END PLAY, AND CODEWHEEL WARP.
 2. MAXIMUM RECOMMENDED MOUNTING SCREW TORQUE IS 4 kg-cm (3.5 in-lbs).

Figure 3. Mounting Plane Side B.

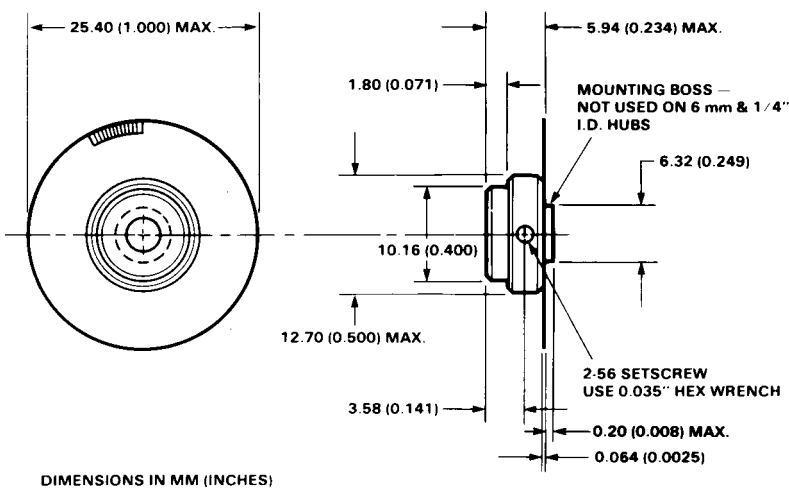

Figure 4. Mounting as Referenced to Side A.

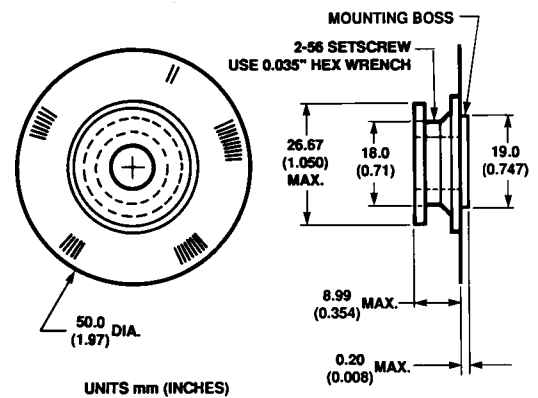

Figure 5. Mounting as Referenced to Side B.

Connectors

Manufacturer	Part Number	Mounting Surface
AMP	1203686-4 640442-5	Both Side B
DuPont	65039-032 with 4825X-000 term.	Both
HP	HEDS-8902 with 4-wire leads	Side B (see Fig. 6)
Molex	2695 series with 2759 series term.	Side B

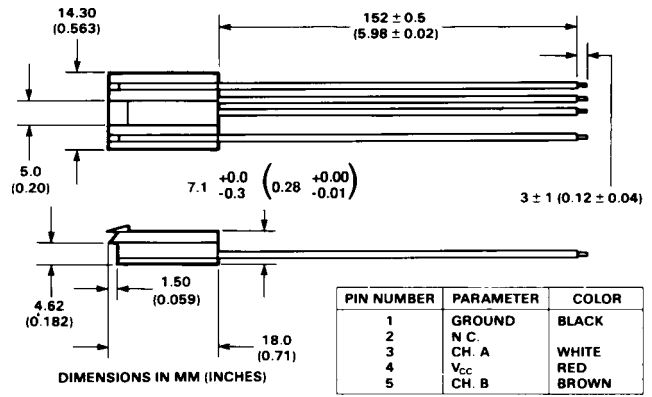

Figure 6. HEDS-8902 Connector.

Ordering Information

HEDS-9000 Option

HEDS-6100 Option

Resolution (Cycles/Rev)
A - 500 CPR
B - 1000 CPR
J - 1024 CPR
T - 2000 CPR*
U - 2048 CPR*

Shaft Diameter	
06 - 1/4 in.	10 - 5/8 in.
08 - 3/8 in.	12 - 6 mm
09 - 1/2 in.	13 - 8 mm

	A	B	C	D	E	F	G	H	I	J	K	L	S	T	U
HEDS-9000	*	*								*				*	*

		01	02	03	04	05	06	08	09	10	11	12	13	14
HEDS-6100	A								*			*	*	
	B						*	*	*	*				

HEDS-910 **0** Option

Lead
0 - Straight Leads
1 - Bent Leads

00

HEDS-5120 Option

Resolution (Cycles/Rev)	
S - 50 CPR	H - 400 CPR
K - 96 CPR	A - 500 CPR
C - 100 CPR	I - 512 CPR
E - 200 CPR	B - 1000 CPR*
F - 256 CPR	J - 1024 CPR*
G - 360 CPR	

Shaft Diameter	
01 - 2 mm	11 - 4 mm
02 - 3 mm	14 - 5 mm
03 - 1/8 in.	12 - 6 mm
04 - 5/32 in.	13 - 8 mm
05 - 3/16 in.	
06 - 1/4 in.	

	A	B	C	D	E	F	G	H	I	J	K	S	T	U
HEDS-9100	*	*	*		*	*	*	*	*	*	*	*		
HEDS-9101	*		*		*		*							

		01	02	03	04	05	06	08	09	10	11	12	13	14
HEDS-5120	A	*	*	*	*	*	*				*	*		*
	C		*				*				*	*	*	*
	D					*								
	E						*					*		
	F					*								
	G		*	*		*	*					*		*
	H		*				*					*	*	*
	I		*		*		*					*	*	*
	K		*											*

For product information and a complete list of distributors, please go to our website: www.avagotech.com

Avago, Avago Technologies, and the A logo are trademarks of Avago Technologies Limited in the United States and other countries. Data subject to change. Copyright © 2006 Avago Technologies Limited. All rights reserved. Obsoletes 5988-5857EN 5988-6712EN November 3, 2006

