

Distributed by:



www.Jameco.com ♦ 1-800-831-4242

The content and copyrights of the attached material are the property of its owner.

Jameco Part Number 1584941

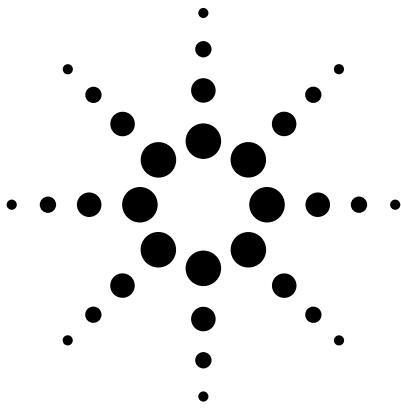

Agilent T-1³/₄ (5 mm) Precision Optical Performance AlInGaP LED Lamps

Data Sheet

SunPower Series

HLMP-ELxx HLMP-EHxx
HLMP-EJxx HLMP-EGxx

Description

These Precision Optical Performance AlInGaP LEDs provide superior light output for excellent readability in sunlight and are extremely reliable. AlInGaP LED technology provides extremely stable light output over long periods of time. Precision Optical Performance lamps utilize the aluminum indium gallium phosphide (AlInGaP) technology.

These LED lamps are untinted, nondiffused, T-1³/₄ packages incorporating second generation optics producing well defined spatial radiation patterns at specific viewing cone angles.

These lamps are made with an advanced optical grade epoxy, offering superior high temperature and high moisture resistance performance in outdoor signal and sign applications. The high maximum LED junction temperature limit of +130°C enables high temperature operation in bright sunlight conditions. The package epoxy contains both uv-a and uv-b inhibitors to reduce the effects of long term exposure to direct sunlight.

These lamps are available in two package options to give the designer flexibility with device mounting.

Features

- Well Defined Spatial Radiation Patterns
- Viewing Angles: 6°, 15°, 23°, 30°
- High Luminous Output
- Colors:
 - 590 nm Amber
 - 605 nm Orange
 - 615 nm Reddish-Orange
 - 626 nm Red
- High Operating Temperature:
T_{J LED} = +130°C
- Superior Resistance to Moisture
- Package Options:
With or Without Lead Stand-Offs

Benefits

- Viewing Angles Match Traffic Management Sign Requirements
- Colors Meet Automotive and Pedestrian Signal Specifications
- Superior Performance in Outdoor Environments
- Suitable for Autoinsertion onto PC Boards

Applications

- Traffic Management:
 - Traffic Signals
 - Pedestrian Signals
 - Work Zone Warning Lights
 - Variable Message Signs
- Commercial Outdoor Advertising:
 - Signs
 - Marquees
- Automotive:
 - Exterior and Interior Lights



Device Selection Guide

Typical Viewing Angle $2\theta_{1/2}$ (Deg.) ^[4]	Color and Dominant Wavelength (nm), Typ. ^[3]	Lamps Without Standoffs on Leads (Outline Drawing A)	Lamps With Standoffs on Leads (Outline Drawing B)	Luminous Intensity Iv (mcd) ^[1,2] @ 20 mA	
				Min.	Max.
6° ^[5]	Amber 590	HLMP-EL08-VY000	HLMP-EL10-VY000	4200	12000
		HLMP-EL08-VYK00*		4200	12000
		HLMP-EL08-VXK00*		4200	9300
		HLMP-EL08-VX400**		4200	9300
		HLMP-EL08-VX000		4200	9300
		HLMP-EL08-WZ000	HLMP-EL10-WZ000	5500	16000
		HLMP-EL08-XZ400**		7200	16000
		HLMP-EL08-XZ000		7200	16000
		HLMP-EL08-XZK00*		7200	16000
		HLMP-EL08-XY000		7200	12000
		HLMP-EL08-XYK00*		7200	12000
		HLMP-EL08-X1K00*		7200	21000
		HLMP-EL08-X1000	HLMP-EL10-X1000	7200	21000
	Orange 605	HLMP-EJ08-WZ000	HLMP-EJ10-WZ000	5500	16000
		HLMP-EJ08-X1000	HLMP-EJ10-X1000	7200	21000
		HLMP-EJ08-Y2000	HLMP-EJ10-Y2000	9300	27000
	Red-Orange 615	HLMP-EH08-UX000	HLMP-EH10-UX000	3200	9300
		HLMP-EH08-VY000	HLMP-EH10-VY000	4200	12000
		HLMP-EH08-WZ000	HLMP-EH10-WZ000	5500	16000
		HLMP-EH08-X1000	HLMP-EH10-X1000	7200	21000
		HLMP-EH08-Y2000	HLMP-EH10-Y2000	9300	21000
	Red 626	HLMP-EG08-VW000		4200	7200
		HLMP-EG08-VY000	HLMP-EG10-VY000	4200	12000
		HLMP-EG08-WZ000	HLMP-EG10-WZ000	5500	16000
		HLMP-EG08-X1000	HLMP-EG10-X1000	7200	21000
		HLMP-EG08-YZ000		9300	16000
		HLMP-EG08-Y1000		9300	21000
		HLMP-EG08-Y2000	HLMP-EG10-Y2000	9300	27000

Notes:

1. The luminous intensity is measured on the mechanical axis of the lamp package.
2. The optical axis is closely aligned with the package mechanical axis.
3. The dominant wavelength, λ_d , is derived from the CIE Chromaticity Diagram and represents the color of the lamp.
4. $\theta_{1/2}$ is the off-axis angle where the luminous intensity is one half the on-axis intensity.
5. The intensity of narrow viewing angle lamps is measured at the intensity peak.

Part numbers in **bold** are recommended for new designs.

*HLMP-xLxx-xxK00 are selected to amber color bins 2 and 4 only.

**HLMP-xLxx-xx400 are selected to amber color bin 4 only.

Device Selection Guide (Continued)

Typical Viewing Angle $2\theta_{1/2}$ (Deg.) ^[4]	Color and Dominant Wavelength (nm), Typ. ^[3]	Lamps Without Standoffs on Leads (Outline Drawing A)	Lamps With Standoffs on Leads (Outline Drawing B)	Luminous Intensity Iv (mcd) ^[1,2] @ 20 mA	
				Min.	Max.
15°	Amber 590	HLMP-EL15-PS000	HLMP-EL17-PS000	880	2500
		HLMP-EL15-QR000		1150	1900
		HLMP-EL15-QRK00*		1150	1900
		HLMP-EL15-QS000		1150	2500
		HLMP-EL15-QS400**		1150	2500
		HLMP-EL15-QSK00*		1150	2500
		HLMP-EL15-QT000	HLMP-EL17-QT000	1150	3200
		HLMP-EL15-QTK00*		1150	3200
		HLMP-EL15-RU000	HLMP-EL17-RU000	1500	4200
			HLMP-EL17-SV000	1900	5500
		HLMP-EL15-TW000	HLMP-EL17-TW000	2500	7200
		HLMP-EL15-TWK00*		2500	7200
		HLMP-EL15-TUK00*		2500	4200
		HLMP-EL15-TV400**		2500	5500
		HLMP-EL15-UX000	HLMP-EL17-UX000	3200	9300
		HLMP-EL15-VY000	HLMP-EL17-VY000	4200	12000
		HLMP-EL15-VYK00*		4200	12000
		HLMP-EL15-VX000		4200	9300
		HLMP-EL15-VXK00*		4200	9300
		HLMP-EL15-VX400**		4200	9300
	HLMP-EL15-VW000*		4200	7200	
	HLMP-EL15-VWK00*		4200	7200	
	Orange 605	HLMP-EJ15-PS000		880	2500
		HLMP-EJ15-RU000	HLMP-EJ17-RU000	1500	4200
		HLMP-EJ15-SV000	HLMP-EJ17-SV000	1900	5500
	Red-Orange 615	HLMP-EH15-QT000	HLMP-EH17-QT000	1150	3200
		HLMP-EH15-RU000	HLMP-EH17-RU000	1500	4200
		HLMP-EH15-TW000	HLMP-EH17-TW000	2500	7200
HLMP-EH15-UX000		HLMP-EH17-UX000	3200	9300	

Notes:

1. The luminous intensity is measured on the mechanical axis of the lamp package.
2. The optical axis is closely aligned with the package mechanical axis.
3. The dominant wavelength, λ_d , is derived from the CIE Chromaticity Diagram and represents the color of the lamp.
4. $\theta_{1/2}$ is the off-axis angle where the luminous intensity is one half the on-axis intensity.
5. The intensity of narrow viewing angle lamps is measured at the intensity peak.

Part numbers in **bold** are recommended for new designs.

*HLMP-xLxx-xxK00 are selected to amber color bins 2 and 4 only.

**HLMP-xLxx-xx400 are selected to amber color bin 4 only.

Device Selection Guide (Continued)

Typical Viewing Angle $2\theta_{1/2}$ (Deg.) ^[4]	Color and Dominant Wavelength (nm), Typ. ^[3]	Lamps Without Standoffs on Leads (Outline Drawing A)	Lamps With Standoffs on Leads (Outline Drawing B)	Luminous Intensity I _v (mcd) ^[1,2] @ 20 mA	
				Min.	Max.
15°	Red 626	HLMP-EG15-PS000		880	2500
		HLMP-EG15-QT000	HLMP-EG17-QT000	1150	3200
		HLMP-EG15-RU000	HLMP-EG17-RU000	1500	4200
		HLMP-EG15-UX000	HLMP-EG17-UX000	3200	9300
		HLMP-EG15-TW000	HLMP-EG17-TW000	2500	7200
23°	Amber 590	HLMP-EL24-MQ000		520	1500
		HLMP-EL24-NR000	HLMP-EL26-NR000	680	1900
		HLMP-EL24-PS000	HLMP-EL26-PS000	880	2500
		HLMP-EL24-PSK00*		880	2500
		HLMP-EL24-PR400**		880	1900
		HLMP-EL24-PQK00*		880	1500
		HLMP-EL24-QR000		1150	1900
		HLMP-EL24-QRK00*		1150	1900
		HLMP-EL24-QS000		1150	2500
		HLMP-EL24-QSK00*		1150	2500
		HLMP-EL24-QS400**		1150	2500
		HLMP-EL24-QT000	HLMP-EL26-QT000	1150	3200
		HLMP-EL24-QTK00*		1150	3200
		HLMP-EL24-RU000	HLMP-EL26-RU000	1500	4200
		HLMP-EL24-RUK00*		1500	4200
			HLMP-EL26-SV000	1900	5500
		HLMP-EL24-STK00*		1900	3200
		HLMP-EL24-SUK00*		1900	4200
		HLMP-EL24-SU400**		1900	4200
		HLMP-EL24-SV000		1900	5500
HLMP-EL24-SVK00*		1900	5500		
HLMP-EL24-TW000	HLMP-EL26-TW000	2500	7200		
HLMP-EL24-TWK00*		2500	7200		

Notes:

1. The luminous intensity is measured on the mechanical axis of the lamp package.
2. The optical axis is closely aligned with the package mechanical axis.
3. The dominant wavelength, λ_d , is derived from the CIE Chromaticity Diagram and represents the color of the lamp.
4. $\theta_{1/2}$ is the off-axis angle where the luminous intensity is one half the on-axis intensity.
5. The intensity of narrow viewing angle lamps is measured at the intensity peak.

Part numbers in **bold** are recommended for new designs.

*HLMP-xLxx-xxK00 are selected to amber color bins 2 and 4 only.

**HLMP-xLxx-xx400 are selected to amber color bin 4 only.

Device Selection Guide (Continued)

Typical Viewing Angle $2\theta_{1/2}$ (Deg.) ^[4]	Color and Dominant Wavelength (nm), Typ. ^[3]	Lamps Without Standoffs on Leads (Outline Drawing A)	Lamps With Standoffs on Leads (Outline Drawing B)	Luminous Intensity I_v (mcd) ^[1,2] @ 20 mA	
				Min.	Max.
23°	Orange 605	HLMP-EJ24-QT000	HLMP-EJ26-QT000	1150	3200
		HLMP-EJ24-RU000	HLMP-EJ26-RU000	1500	4200
	Red-Orange 615		HLMP-EH26-PS000	880	2500
		HLMP-EH24-QT000	HLMP-EH26-QT000	1150	3200
		HLMP-EH24-RU000	HLMP-EH26-RU000	1500	4200
	Red 626	HLMP-EH24-SV000	HLMP-EH26-SV000	1900	5500
		HLMP-EG24-PS000	HLMP-EG26-PS000	880	2500
		HLMP-EG24-QT000	HLMP-EG26-QT000	1150	3200
	30°	Amber 590	HLMP-EG24-RU000	HLMP-EG26-RU000	1500
HLMP-EL30-MQ000			HLMP-EL32-MQ000	520	1500
HLMP-EL30-NR000			HLMP-EL32-NR000	680	1900
HLMP-EL30-PQ000				880	1500
HLMP-EL30-PQK00*				880	1500
HLMP-EL30-PR000				880	1900
HLMP-EL30-PR400**				880	1900
HLMP-EL30-PRK00*				880	1900
HLMP-EL30-PS000			HLMP-EL32-PS000	880	2500
HLMP-EL30-PSK00*				880	2500
HLMP-EL30-QRK00*				1150	1900
HLMP-EL30-QS000				1150	2500
HLMP-EL30-QS400**				1150	2500
HLMP-EL30-QT000			HLMP-EL32-QT000	1150	3200
HLMP-EL30-QTK00*				1150	3200
HLMP-EL30-ST000				1900	3200
HLMP-EL30-SU000				1900	4200
HLMP-EL30-SU400**				1900	4200
HLMP-EL30-SUK00*		1900	4200		

Notes:

1. The luminous intensity is measured on the mechanical axis of the lamp package.
2. The optical axis is closely aligned with the package mechanical axis.
3. The dominant wavelength, λ_d , is derived from the CIE Chromaticity Diagram and represents the color of the lamp.
4. $\theta_{1/2}$ is the off-axis angle where the luminous intensity is one half the on-axis intensity.
5. The intensity of narrow viewing angle lamps is measured at the intensity peak.

Part numbers in **bold** are recommended for new designs.

*HLMP-xLxx-xxK00 are selected to amber color bins 2 and 4 only.

**HLMP-xLxx-xx400 are selected to amber color bin 4 only.

Device Selection Guide (Continued)

Typical Viewing Angle $2\theta_{1/2}$ (Deg.) ^[4]	Color and Dominant Wavelength (nm), Typ. ^[3]	Lamps Without Standoffs on Leads (Outline Drawing A)	Lamps With Standoffs on Leads (Outline Drawing B)	Luminous Intensity I _v (mcd) ^[1,2] @ 20 mA	
				Min.	Max.
30°	Amber	HLMP-EL30-STK00*		1900	3200
		HLMP-EL30-SV000		1900	5500
		HLMP-EL30-SVK00*		1900	5500
			HLMP-EL32-SV000	1900	5500
	Orange 605	HLMP-EJ30-MQ000		520	1500
		HLMP-EJ30-NR000	HLMP-EJ32-NR000	680	1900
		HLMP-EJ30-PS000	HLMP-EJ32-PS000	880	2500
	Red-Orange 615	HLMP-EH30-MQ000	HLMP-EH32-MQ000	520	1500
		HLMP-EH30-NR000	HLMP-EH32-NR000	680	1900
		HLMP-EH30-PS000	HLMP-EH32-PS000	880	2500
		HLMP-EH30-QT000	HLMP-EH32-QT000	1150	3200
		HLMP-EH30-RU000	HLMP-EH32-RU000	1500	4200
	Red 626	HLMP-EG30-KN000		310	880
		HLMP-EG30-MQ000	HLMP-EG32-MQ000	520	1500
		HLMP-EG30-NQ000		680	1500
		HLMP-EG30-NR000	HLMP-EG32-NR000	680	1900
		HLMP-EG30-PQ000		880	1500
		HLMP-EG30-PR000		880	1900
		HLMP-EG30-PS000	HLMP-EG32-PS000	880	2500
		HLMP-EG30-QT000	HLMP-EG32-QT000	1150	3200

Notes:

1. The luminous intensity is measured on the mechanical axis of the lamp package.
2. The optical axis is closely aligned with the package mechanical axis.
3. The dominant wavelength, λ_d , is derived from the CIE Chromaticity Diagram and represents the color of the lamp.
4. $\theta_{1/2}$ is the off-axis angle where the luminous intensity is one half the on-axis intensity.
5. The intensity of narrow viewing angle lamps is measured at the intensity peak.

Part numbers in **bold** are recommended for new designs.

*HLMP-xLxx-xxK00 are selected to amber color bins 2 and 4 only.

**HLMP-xLxx-xx400 are selected to amber color bin 4 only.

Part Numbering System

HLMP - x x xx - x x x xx

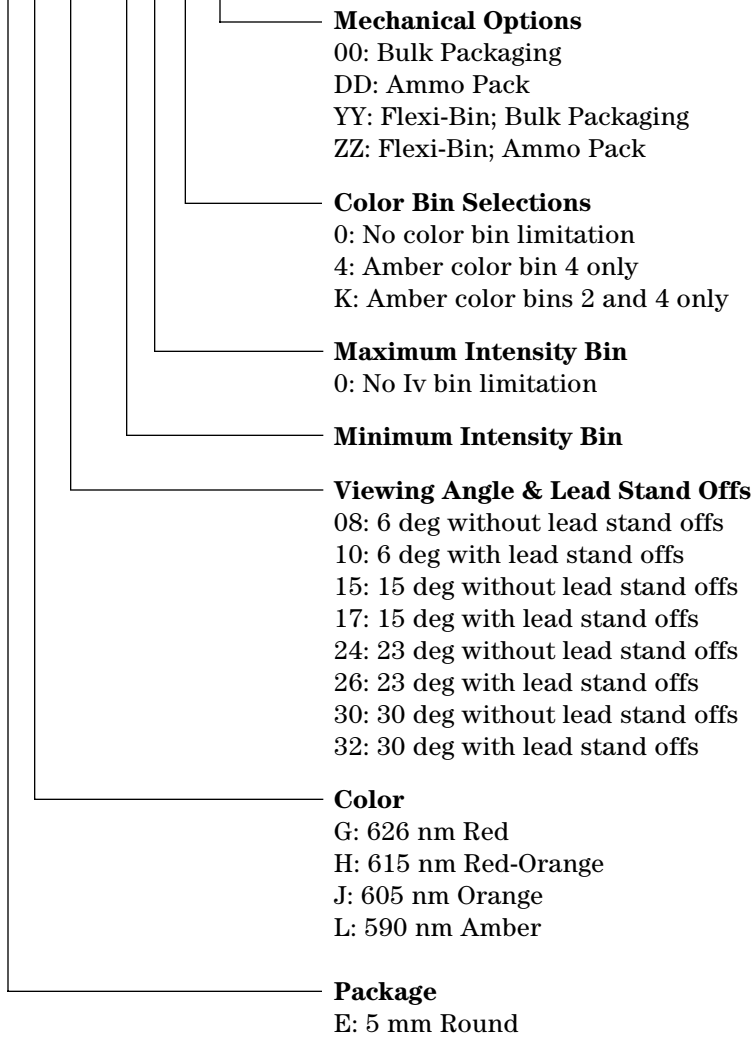

Package Dimensions

A

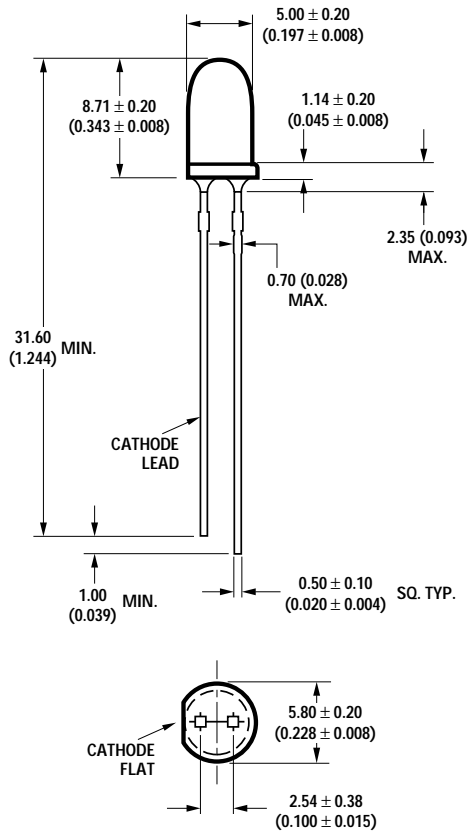

B

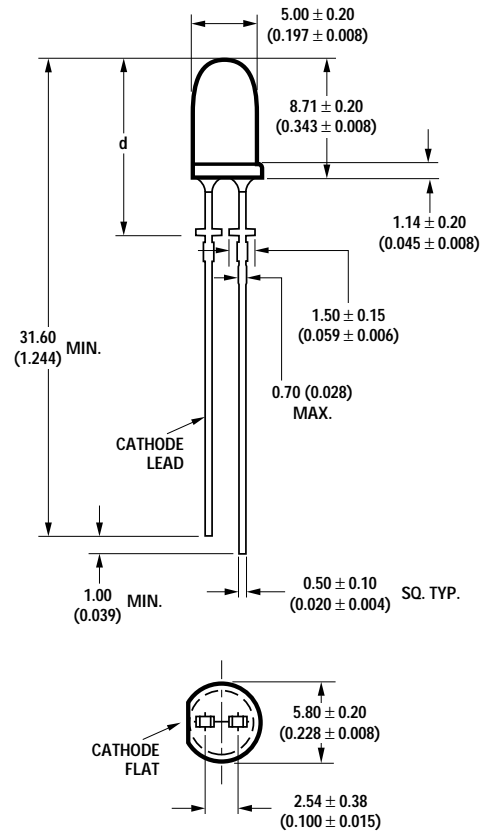

NOTES:

1. ALL DIMENSIONS ARE IN MILLIMETERS (INCHES).
2. LEADS ARE MILD STEEL, SOLDER DIPPED.
3. TAPERS SHOWN AT TOP OF LEADS (BOTTOM OF LAMP PACKAGE) INDICATE AN EPOXY MENISCUS THAT MAY EXTEND ABOUT 1 mm (0.040 in.) DOWN THE LEADS.
4. RECOMMENDED PC BOARD HOLE DIAMETERS:
 - LAMP PACKAGE A WITHOUT STAND-OFFS: FLUSH MOUNTING AT BASE OF LAMP PACKAGE = 1.143/1.067 (0.044/0.042).
 - LAMP PACKAGE B WITH STAND-OFFS: MOUNTING AT LEAD STAND-OFFS = 0.965/0.889 (0.038/0.035).
5. FOR DOME HEIGHTS ABOVE LEAD STAND-OFF SEATING PLANE, d, LAMP PACKAGE B, SEE TABLE.

PART NO.	d
HLMP-XX10	12.37 ± 0.25 (0.487 ± 0.010)
HLMP-XX17	12.42 ± 0.25 (0.489 ± 0.010)
HLMP-XX26	12.52 ± 0.25 (0.493 ± 0.010)
HLMP-XX32	11.96 ± 0.25 (0.471 ± 0.010)

Absolute Maximum Ratings at $T_A = 25^\circ\text{C}$

DC Forward Current ^[1,2,3]	50 mA
Peak Pulsed Forward Current ^[2,3]	100 mA
Average Forward Current ^[3]	30 mA
Reverse Voltage ($I_R = 100 \mu\text{A}$)	5 V
LED Junction Temperature	130°C
Operating Temperature	-40°C to +100°C
Storage Temperature	-40°C to +120°C
Solder Dipping Temperature	260°C for 5 seconds
Wave Solder Temperature	250°C for 3 seconds
[1.59 mm (0.060 in.) below body]	

Notes:

1. Derate linearly as shown in Figure 4.
2. For long term performance with minimal light output degradation, drive currents between 10 mA and 30 mA are recommended. For more information on recommended drive conditions, please refer to Application Brief I-024 (5966-3087E).
3. Operating at currents below 1 mA is not recommended. Please contact your local representative for further information.

Electrical/Optical Characteristics at $T_A = 25^\circ\text{C}$

Parameter	Symbol	Min.	Typ.	Max.	Units	Test Conditions
Forward Voltage						$I_F = 20 \text{ mA}$
Amber ($\lambda_d = 590 \text{ nm}$)			2.02			
Orange ($\lambda_d = 605 \text{ nm}$)	V_F		1.98	2.4	V	
Red-Orange ($\lambda_d = 615 \text{ nm}$)			1.94			
Red ($\lambda_d = 626 \text{ nm}$)			1.90			
Reverse Voltage	V_R	5	20		V	$I_F = 100 \mu\text{A}$
Peak Wavelength:						Peak of Wavelength of Spectral Distribution at $I_F = 20 \text{ mA}$
Amber ($\lambda_d = 590 \text{ nm}$)			592			
Orange ($\lambda_d = 605 \text{ nm}$)	λ_{PEAK}		609		nm	
Red-Orange ($\lambda_d = 615 \text{ nm}$)			621			
Red ($\lambda_d = 626 \text{ nm}$)			635			
Spectral Halfwidth	$\Delta\lambda_{1/2}$		17		nm	Wavelength Width at Spectral Distribution $1/2$ Power Point at $I_F = 20 \text{ mA}$
Speed of Response	τ_s		20		ns	Exponential Time Constant, e^{-t/τ_s}
Capacitance	C		40		pF	$V_F = 0, f = 1 \text{ MHz}$
Thermal Resistance	$R\theta_{J-PIN}$		240		$^\circ\text{C}/\text{W}$	LED Junction-to-Cathode Lead
Luminous Efficacy ^[1]						Emitted Luminous Power/Emitted Radiant Power
Amber ($\lambda_d = 590 \text{ nm}$)			480			
Orange ($\lambda_d = 605 \text{ nm}$)	η_V		370		lm/W	
Red-Orange ($\lambda_d = 615 \text{ nm}$)			260			
Red ($\lambda_d = 626 \text{ nm}$)			150			

Note:

1. The radiant intensity, I_e , in watts per steradian, may be found from the equation $I_e = I_v/\eta_v$, where I_v is the luminous intensity in candelas and η_v is the luminous efficacy in lumens/watt.

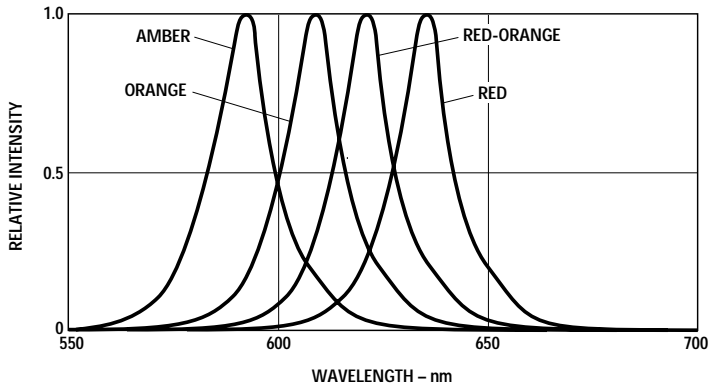

Figure 1. Relative Intensity vs. Peak Wavelength.

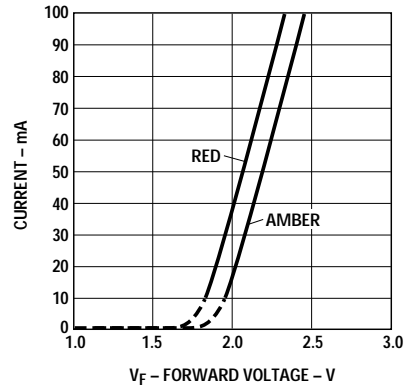

Figure 2. Forward Current vs. Forward Voltage.

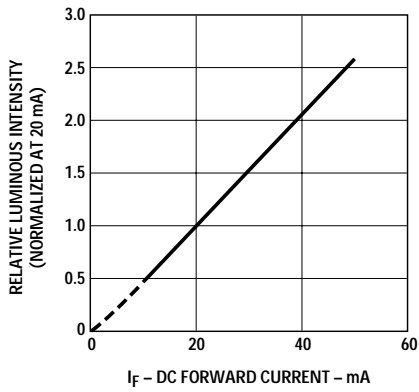

Figure 3. Relative Luminous Intensity vs. Forward Current.

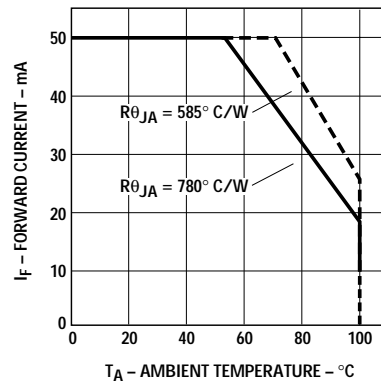

Figure 4. Maximum Forward Current vs. Ambient Temperature. Derating Based on $T_{JMAX} = 130^{\circ}C$.

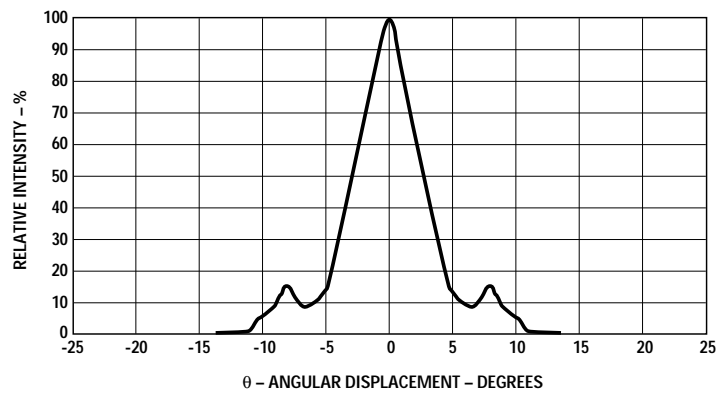

Figure 5. Representative Spatial Radiation Pattern for 6° Viewing Angle Lamps.

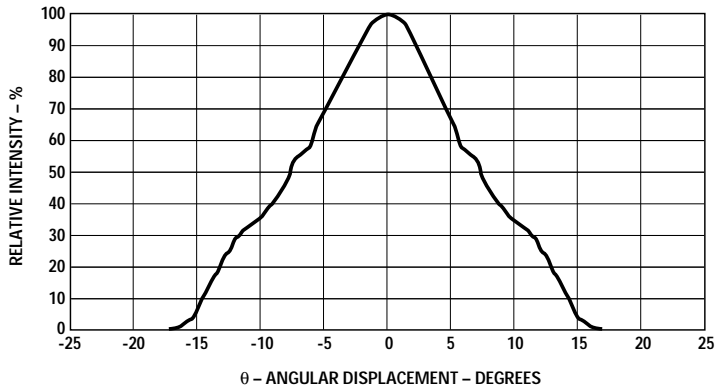

Figure 6. Representative Spatial Radiation Pattern for 15° Viewing Angle Lamps.

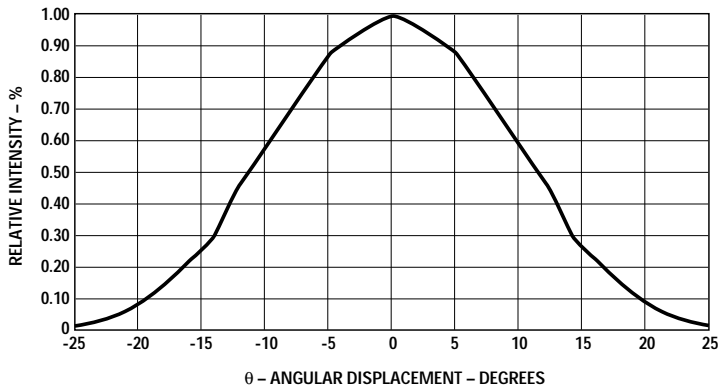

Figure 7. Representative Spatial Radiation Pattern for 23° Viewing Angle Lamps.

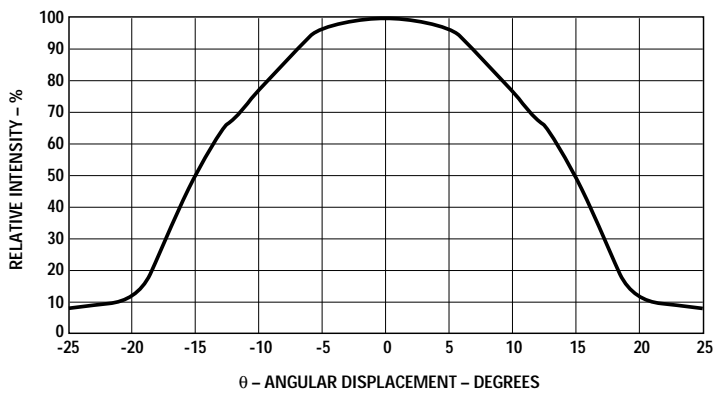

Figure 8. Representative Spatial Radiation Pattern for 30° Viewing Angle Lamps.

Intensity Bin Limits (mcd at 20 mA)

Bin Name	Min.	Max.
K	310	400
L	400	520
M	520	680
N	680	880
P	880	1150
Q	1150	1500
R	1500	1900
S	1900	2500
T	2500	3200
U	3200	4200
V	4200	5500
W	5500	7200
X	7200	9300
Y	9300	12000
Z	12000	16000
1	16000	21000
2	21000	27000

Tolerance for each bin limit is $\pm 15\%$.

Amber Color Bin Limits (nm at 20 mA)

Bin Name	Min.	Max.
1	584.5	587.0
2	587.0	589.5
4	589.5	592.0
6	592.0	594.5

Tolerance for each bin limit is ± 0.5 nm.

Note:

- Bin categories are established for classification of products. Products may not be available in all bin categories.

www.agilent.com/semiconductors

For product information and a complete list of distributors, please go to our web site.

For technical assistance call:

Americas/Canada: +1 (800) 235-0312 or
(916) 788-6763

Europe: +49 (0) 6441 92460

China: 10800 650 0017

Hong Kong: (+65) 6756 2394

India, Australia, New Zealand: (+65) 6755 1939

Japan: (+81 3) 3335-8152(Domestic/International), or 0120-61-1280(Domestic Only)

Korea: (+65) 6755 1989

Singapore, Malaysia, Vietnam, Thailand,
Philippines, Indonesia: (+65) 6755 2044

Taiwan: (+65) 6755 1843

Data subject to change.

Copyright © 2005 Agilent Technologies, Inc.

Obsoletes 5989-0659EN

April 27, 2005

5989-2916EN



Agilent Technologies