

PART NAME	ECONOBOXES	PART No.	CU-5123 TO CU-5347 & CU-5123-B TO CU-5347-B	REV. DATE	9-21-04
-----------	------------	----------	---	-----------	---------

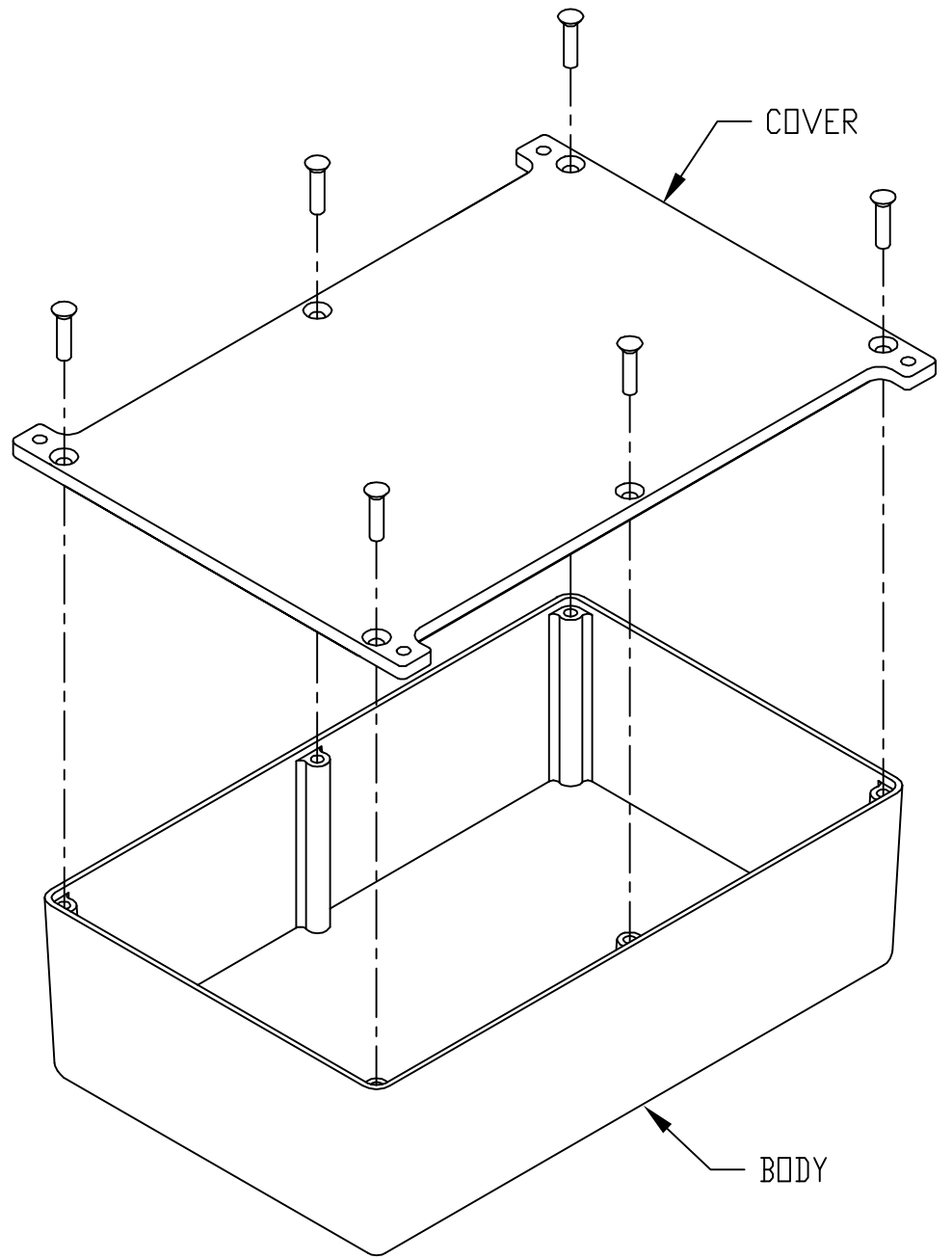

MATERIAL:
ALUMINUM ALLOY #ADC-10
FINISH:
NATURAL (NO SUFFIX)
SMOOTH BLACK (SUFFIX -B)

ALL INTERNAL FILLETS 0.062 RADIUS
ALL INTERNAL ROUNDS 0.125 RADIUS
ALL EXTERNAL ROUNDS 0.125 RADIUS
ALL BOXES ASSEMBLED WITH #6-32 FLAT HD. SCREWS

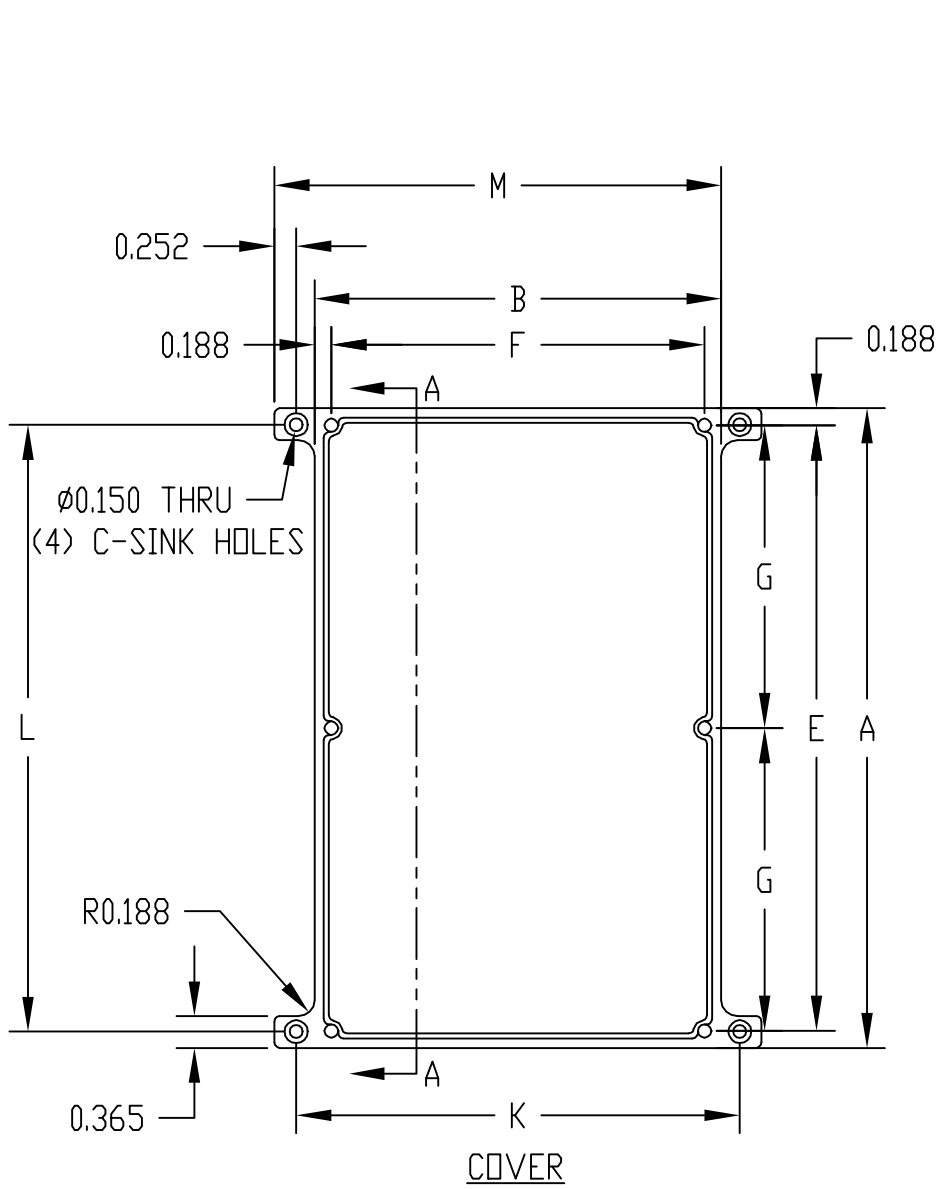
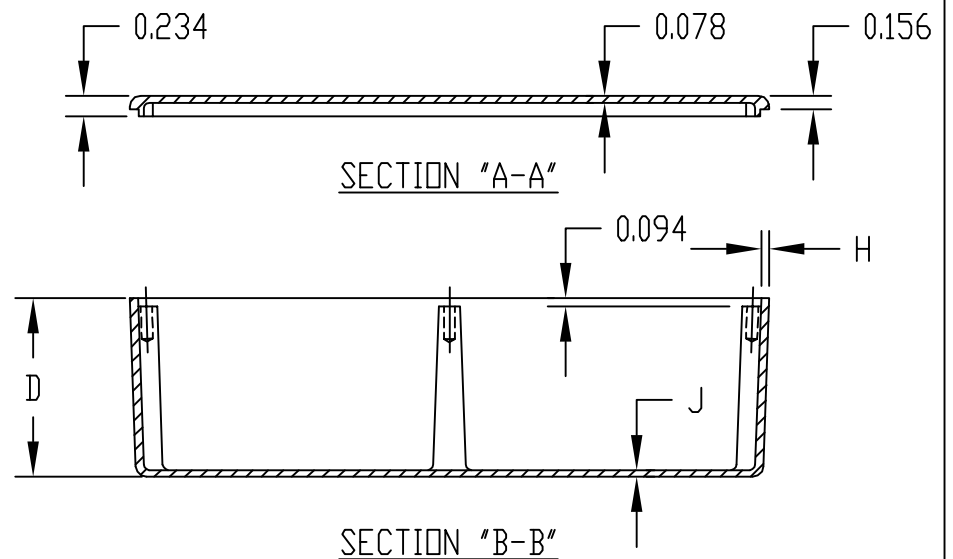
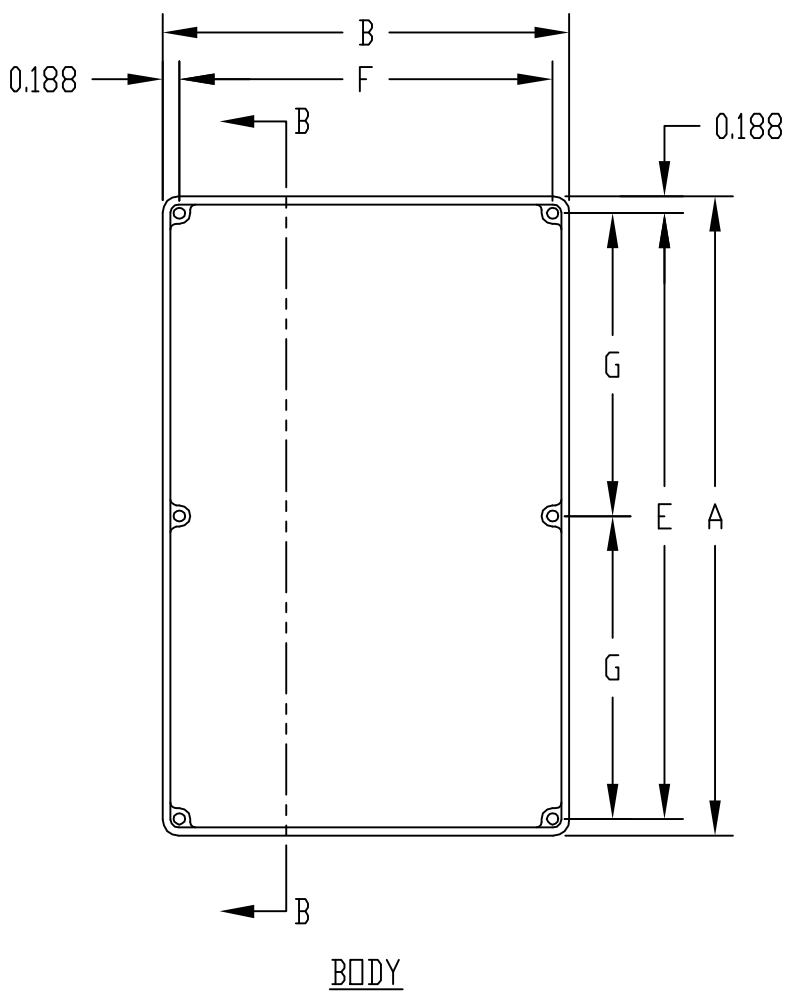

* ASSEMBLED HEIGHT

PART NO.	PART NO.	A	B	* C	D	E	F	G	H	J	K	L	M
CU-5123	CU-5123-B	3.625	1.500	1.218	1.062	3.250	1.125	---	0.062	0.062	1.975	3.250	1.987
CU-5124	CU-5124-B	4.375	2.375	1.218	1.062	4.000	2.000	---	0.062	0.078	2.840	3.991	2.842
CU-5234	CU-5234-B	4.688	3.688	2.218	2.062	4.312	3.312	---	0.094	0.078	4.149	4.310	4.175
CU-5247	CU-5247-B	7.390	4.703	2.218	2.062	7.000	4.312	3.500	0.094	0.078	5.120	7.012	5.168
CU-5347	CU-5347-B	7.390	4.703	3.218	3.062	7.000	4.312	3.500	0.094	0.078	5.118	7.020	5.167