

ADJUSTABLE PRECISION SHUNT REGULATOR

Description

The AP431 and AP431A are 3-terminal adjustable precision shunt regulators with guaranteed temperature stability over the applicable extended commercial temperature range. The output voltage may be set at any level greater than 2.495V (V_{REF}) up to 36V merely by selecting two external resistors that act as a voltage divider network. These devices have a typical output impedance of 0.2Ω. Active output circuitry provides very sharp turn-on characteristics, making these devices excellent improved replacements for Zener diodes in many applications.

The precise (+/-) 1% reference voltage tolerance of the AP431/AP431A make it possible in many applications to avoid the use of a variable resistor, consequently saving cost and eliminating drift and reliability problems associated with it.

Features

- Precision Reference Voltage
- AP431: 2.495V ± 1%
- AP431A: 2.495V ± 0.5%
- Sink Current Capability: 200mA
- Minimum Cathode Current for Regulation: 300μA
- Equivalent Full-Range Temp Coefficient: 30ppm/°C
- Fast Turn-On Response
- Low Dynamic Output Impedance: 0.2Ω
- Programmable Output Voltage to 36V
- Low Output Noise
- Lead Free Packages: SOT25, SC59, SC59R, SOT89 SO-8 and TO92
 - **Totally Lead-Free; RoHS Compliant (Notes 1 & 2)**
- SOT23, SOT23R, SOT25, SC59, SC59R, SO-8, SOT89, TO92: Available in "Green" Molding Compound (No Br, Sb). See "Ordering Information"
 - **Halogen and Antimony Free. "Green" Device (Note 3)**

Notes: 1. No purposely added lead. Fully EU Directive 2002/95/EC (RoHS) & 2011/65/EU (RoHS 2) compliant.
 2. See <http://www.diodes.com> for more information about Diodes Incorporated's definitions of Halogen- and Antimony-free, "Green" and Lead-free.
 3. Halogen- and Antimony-free "Green" products are defined as those which contain <900ppm bromine, <900ppm chlorine (<1500ppm total Br + Cl) and <1000ppm antimony compounds.

Pin Assignments

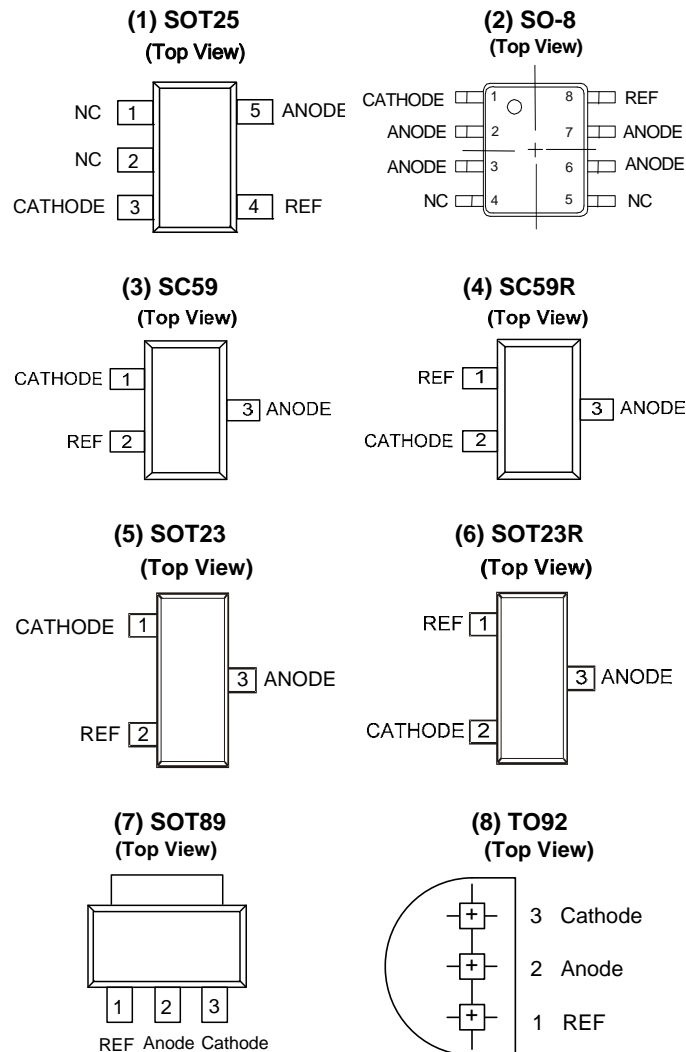

Typical Applications Circuit

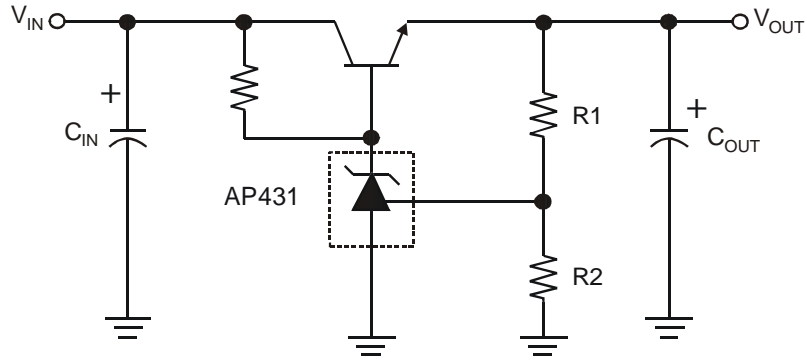

$$V_{OUT} = (1 + R1 / R2) V_{REF}$$

Precision Regulator

Symbol

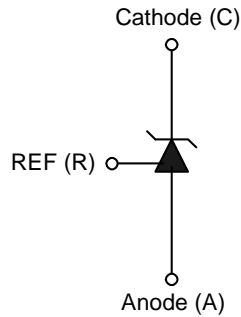

Functional Block Diagram

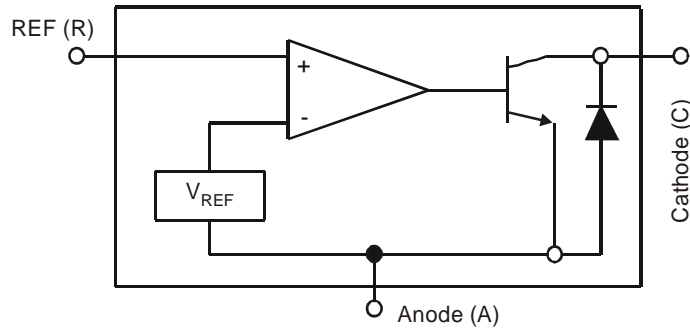

Absolute Maximum Ratings (@T_A = +25°C, unless otherwise specified.)

| Parameter | | Rating | Unit |
|--------------------------------|----------|-------------|------|
| Cathode Voltage | | +36 | V |
| Continuous Cathode Current | | -10 to +250 | mA |
| Reference Input Current | | 10 | mA |
| Operating Temperature | | -20 to +85 | °C |
| Storage Temperature | | -65 to +150 | °C |
| Power Dissipation (Notes 4, 5) | SOT23(R) | 400 | mW |
| | SOT25 | 550 | mW |
| | SC59(R) | 400 | mW |
| | SO-8 | 600 | mW |
| | SOT89 | 800 | mW |
| | TO92 | 780 | mW |

Notes: 4. T_J, max = +150°C.
5. Ratings apply to ambient temperature at +25°C.

Electrical Characteristics (@T_A = +25°C, V_{DD} = 3V; unless otherwise specified.)

| Symbol | Parameter | Conditions | Min | Typ | Max | Units | |
|--|---|--|---|-------|----------------|-------|------|
| V _{REF} | Reference voltage | V _{KA} = V _{REF} , I _{KA} = 10mA (Figure 1) AP431 AP431A | 2.470 2.482 | 2.495 | 2.520 2.507 | V | |
| V _{DEV} | Deviation of reference input voltage over temperature (Note 5) | V _{KA} = V _{REF} , I _{KA} = 10mA T _A = Full Range (Figure 1) | — | 8.0 | 20.0 | mV | |
| $\frac{\Delta V_{REF}}{\Delta V_{KA}}$ | Ratio of the change in reference voltage to the change in cathode voltage | I _{KA} = 10mA (Figure 2) | V _{KA} = V _{REF} to 10V | — | -1.4 | -2.0 | mV/V |
| | | | V _{KA} = 10V to 36V | — | -1 | -2 | mV/V |
| I _{REF} | Reference input current | R1 = 10KΩ, R2 = ∞ I _{KA} = 10mA (Figure 2) | — | 1.4 | 3.5 | μA | |
| αI _{REF} | Deviation of reference input current over temperature | R1 = 10KΩ, R2 = ∞ I _{KA} = 10mA T _A = Full range (Figure 2) | — | 0.4 | 1.2 | μA | |
| I _{KA(MIN)} | Minimum cathode current for regulation | V _{KA} = V _{REF} (Figure 1) | — | 0.19 | 0.50 | mA | |
| I _{KA(OFF)} | Off-state current | V _{KA} = 36V, V _{REF} = 0V (Figure 3) | — | 0.1 | 1.0 | μA | |
| Z _{KA} | Dynamic output impedance (Note 7) | V _{KA} = V _{REF} V _{KA} = V _{REF} ΔI _{KA} = 0.1mA to 15mA Frequency ≤ 1KHz (Figure 1) | — | 0.2 | 0.5 | Ω | |

Electrical Characteristics (cont.) (@T_A = +25°C, V_{DD} = 3V; unless otherwise specified.)

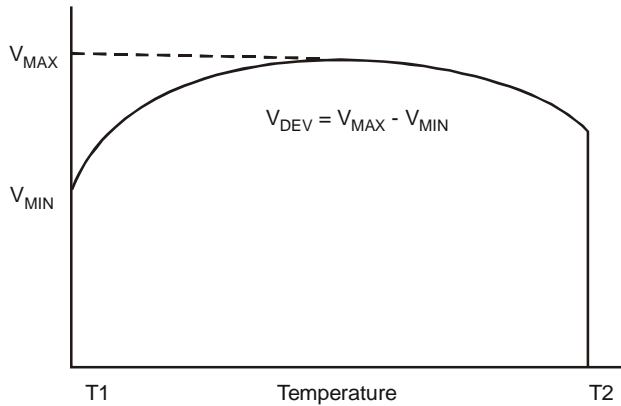

Notes: 6. Deviation of reference input voltage, V_{DEV} , is defined as the maximum variation of the reference over the full temperature range. The average temperature coefficient of the reference input voltage αV_{REF} is defined as:

$$|\alpha V_{REF}| = \frac{\left(\frac{V_{DEV}}{V_{REF}(25^\circ\text{C})}\right) \cdot 10^6}{T_2 - T_1} \dots\dots\dots (\text{ppm}/^\circ\text{C})$$

Where:

$T_2 - T_1$ = full temperature change.

αV_{REF} can be positive or negative depending on whether the slope is positive or negative.

Notes: 7. The dynamic output impedance, R_Z , is defined as:

$$|Z_{KA}| = \frac{\Delta V_{KA}}{\Delta I_{KA}}$$

When the device is programmed with two external resistors $R1$ and $R2$ (see Figure 2.), the dynamic output impedance of the overall circuit, is defined as:

$$|Z_{KA}| = \frac{\Delta V}{\Delta i} \approx |Z_{KA}| \left(1 + \frac{R1}{R2}\right)$$

Test Conditions

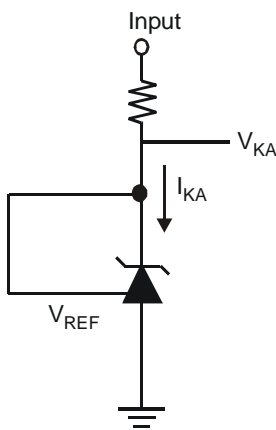
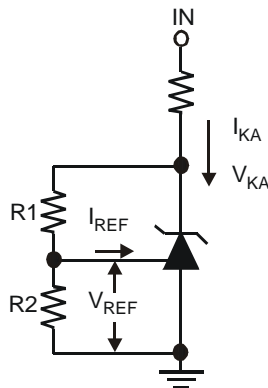

Figure. 1 Test Circuit for $V_{KA} = V_{REF}$



Note: $V_{KA} = V_{REF} (1 + R1/R2) + I_{REF} \times R1$

Figure. 2 Test Circuit for $V_{KA} > V_{REF}$

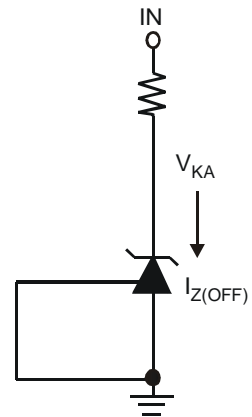
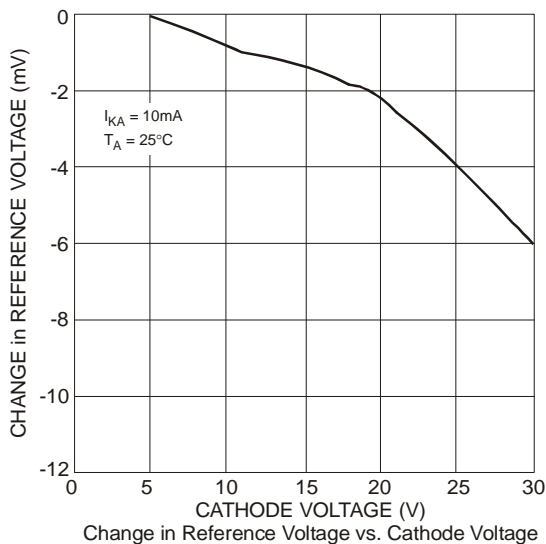
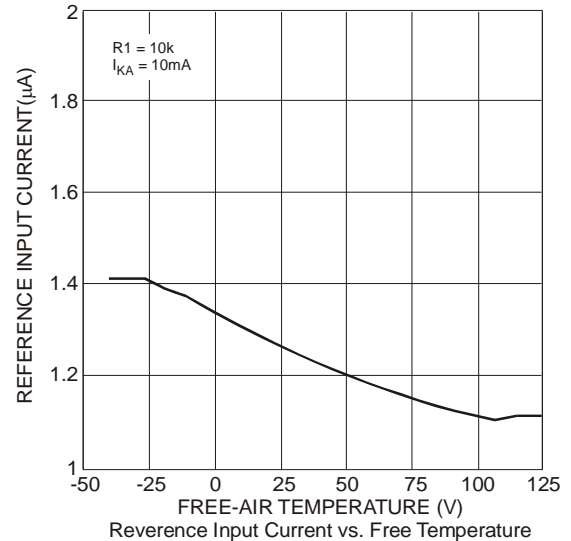
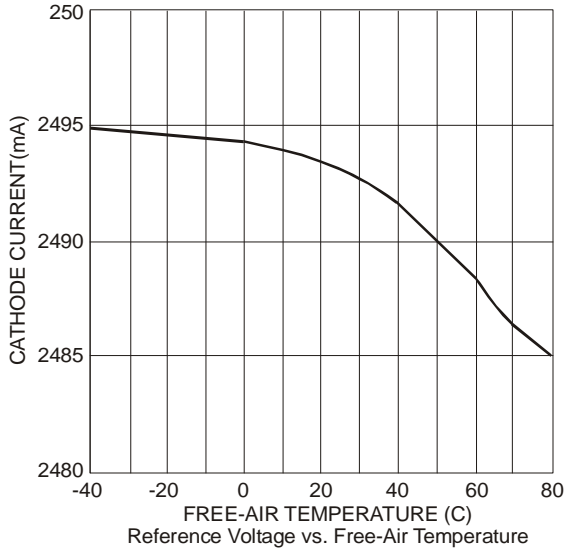
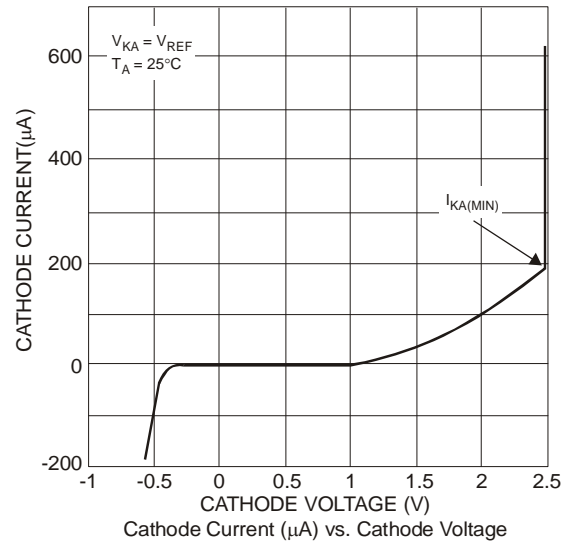
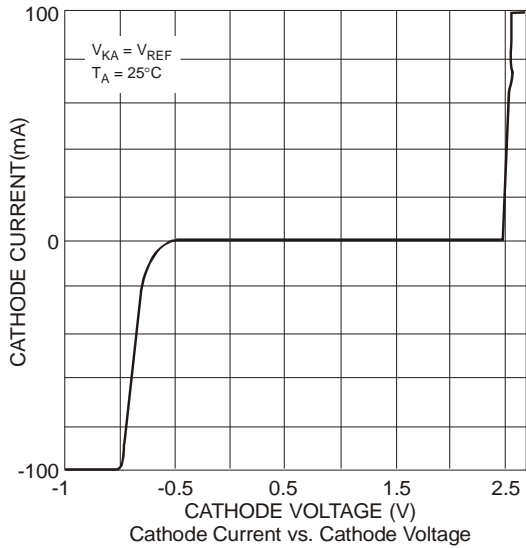
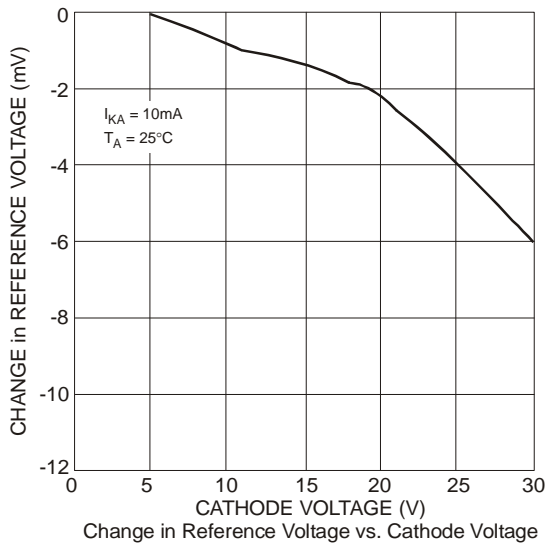
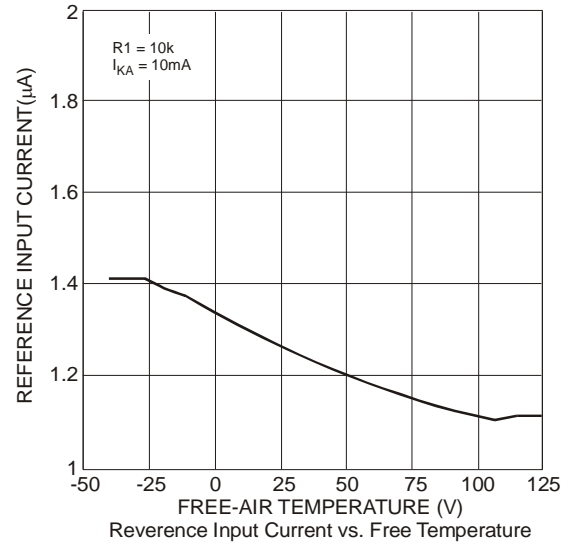
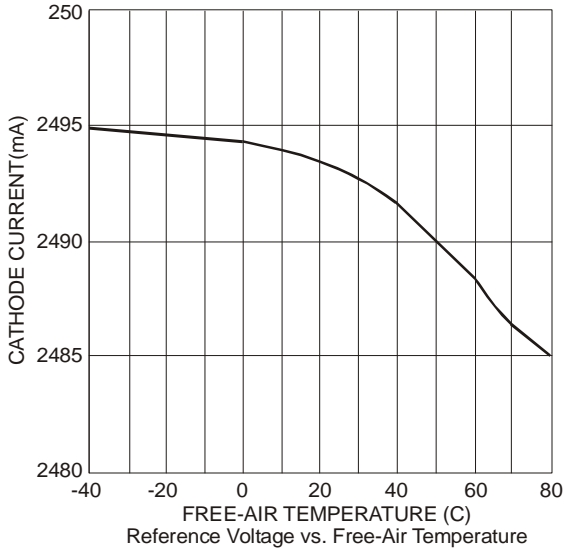
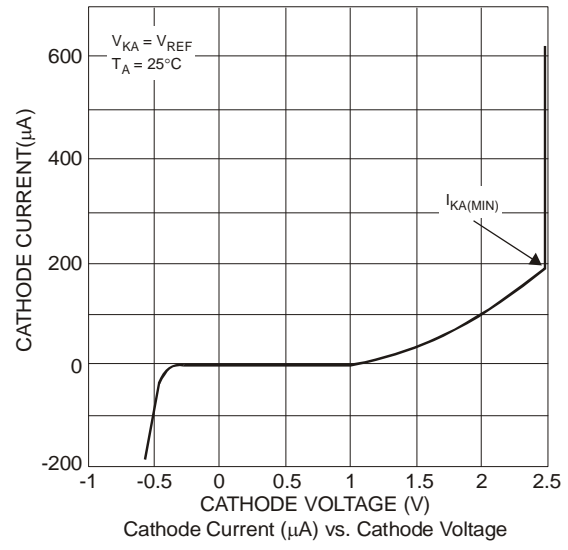
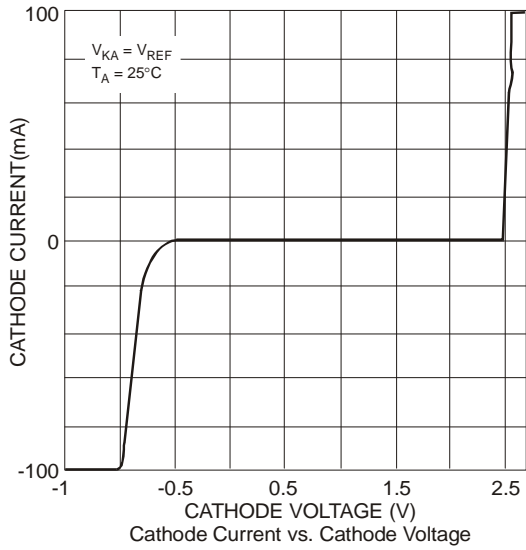

Figure. 3 Test Circuit for Off-State Current

Typical Performance Characteristics



Typical Performance Characteristics (cont.)



Typical Performance Characteristics (cont.)

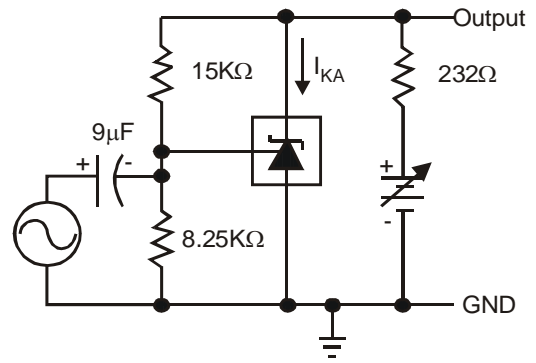
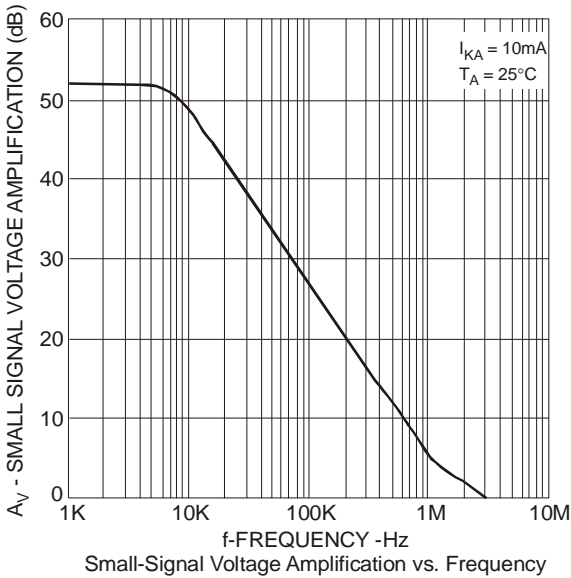

Test Circuit for Voltage Amplification

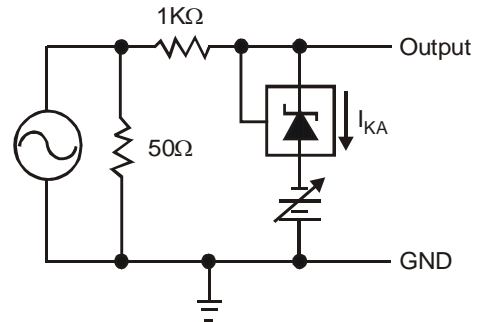
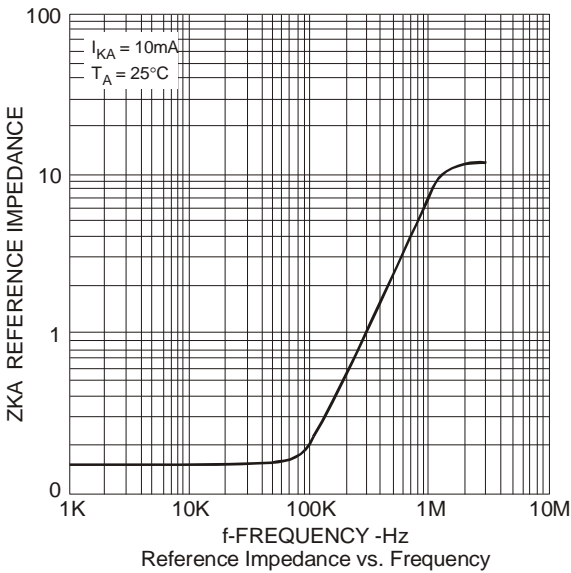

Test Circuit for Reference Impedance

Typical Performance Characteristics (cont.)

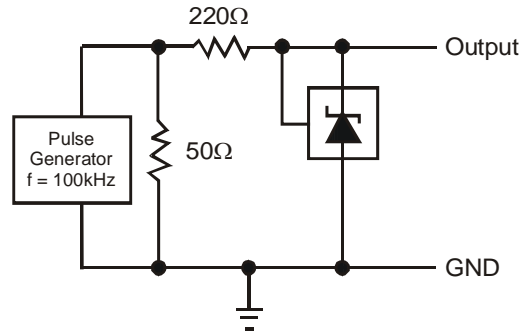
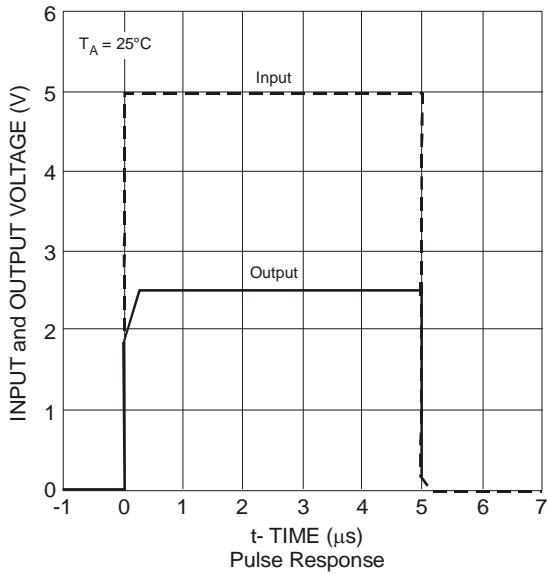

Test Circuit for Pulse Response

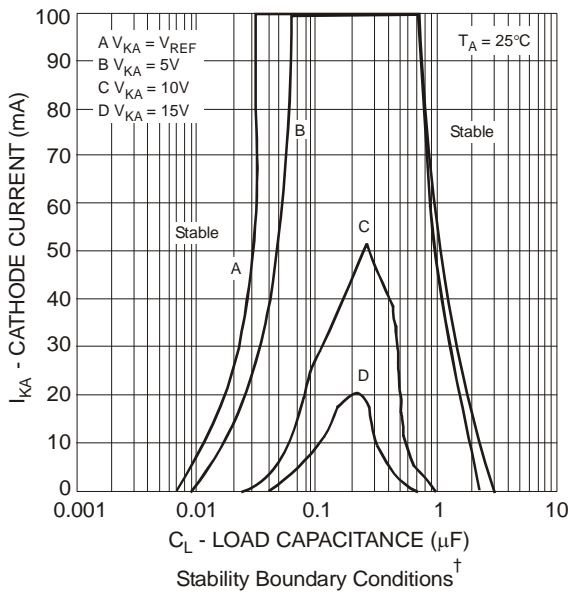

[†]The areas under the curves represent conditions that may cause the device to oscillate. For curves B, C, and D, R2 and V+ were adjusted to establish the initial V_{KA} and I_{KA} conditions with $C_L = 0$. V_{BATT} and C_L were then adjusted to determine the ranges of stability.

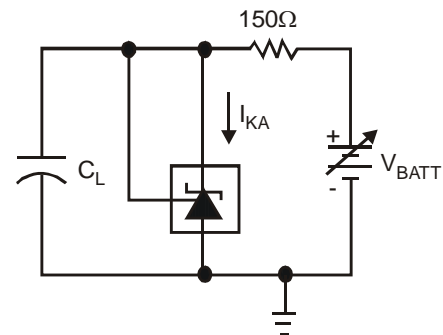

Test Circuit for Curve A

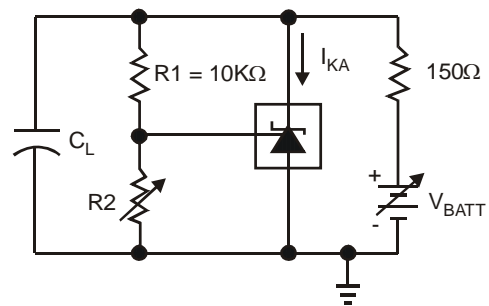

Test Circuit for Curve B, C, and D

Ordering Information

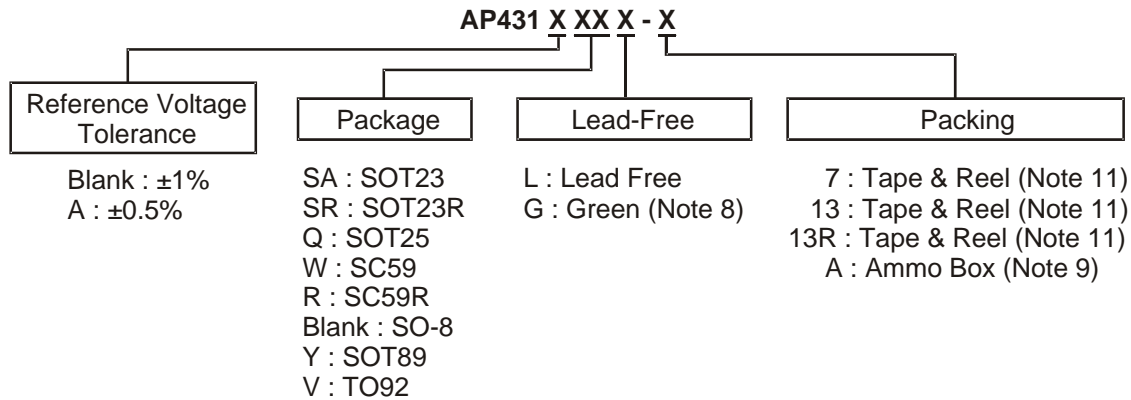

| Part Number (Note 10) | Package Code | Packaging | 7"/13 Tape and Reel | | Ammo Box | |
|--------------------------|--------------|-----------|---------------------|---------------------------------|----------|--------------------|
| | | | Quantity | Part Number Suffix (Note 11) | Quantity | Part Number Suffix |
| AP431(A)SAG-7 | SA | SOT23 | 3000/Tape & Reel | -7 | NA | NA |
| AP431(A)SRG-7 | SR | SOT23R | 3000/Tape & Reel | -7 | NA | NA |
| AP431(A)QL-7 | Q | SOT25 | 3000/Tape & Reel | -7 | NA | NA |
| AP431(A)QG-7 | Q | SOT25 | 3000/Tape & Reel | -7 | NA | NA |
| AP431(A)WL-7 | W | SC59 | 3000/Tape & Reel | -7 | NA | NA |
| AP431(A)WG-7 | W | SC59 | 3000/Tape & Reel | -7 | NA | NA |
| AP431(A)RL-7 | R | SC59R | 3000/Tape & Reel | -7 | NA | NA |
| AP431(A)RG-7 | R | SC59R | 3000/Tape & Reel | -7 | NA | NA |
| AP431(A)G-13 | | SO-8 | 2500/Tape & Reel | -13 | NA | NA |
| AP431(A)YL-13 | Y | SOT89 | 2500/Tape & Reel | -13 | NA | NA |
| AP431(A)YG-13 | Y | SOT89 | 2500/Tape & Reel | -13 | NA | NA |
| AP431(A)YG-13R | Y | SOT89 | 4000/Tape & Reel | -13R | NA | NA |
| AP431(A)VL-A | V | TO92 | NA | NA | 2000/Box | NA |
| AP431(A)VG-A | V | TO92 | NA | NA | 2000/Box | NA |

- Notes:
- 8. SO-8, SOT23 and SOT23R are available in "Green" products only.
 - 9. Ammo Box is for TO92 Spread Lead.
 - 10. Suffix "A" denotes AP431A device.
 - 11. Details of tape and reel options can be seen in document AP2007, which can be found on our website at <http://www.diodes.com/datasheets/ap02007.pdf>

Marking Information

(1) SC59 and SC59R

(Top View)

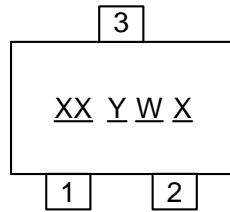

XX : Identification code
Y : Year 0~9
W : Week : A~Z : 1~26 week;
a~z : 27~52 week; z represents
52 and 53 week
X : A~Z : Green
a~z : Lead Free

(2) SOT23 and SOT23R

(Top View)

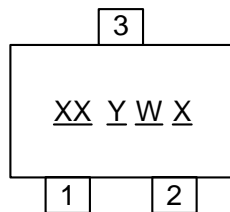

XX : Identification code
Y : Year 0~9
W : Week : A~Z : 1~26 week;
a~z : 27~52 week; z represents
52 and 53 week
X : A~Z : Green

(3) SOT25

(Top View)

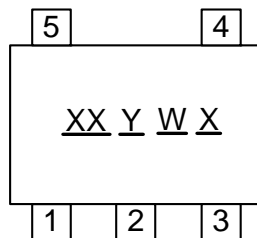

XX : Identification code
Y : Year 0~9
W : Week : A~Z : 1~26 week;
a~z : 27~52 week; z represents
52 and 53 week
X : A~Z : Green
a~z : Lead Free

(4) SO-8

(Top View)

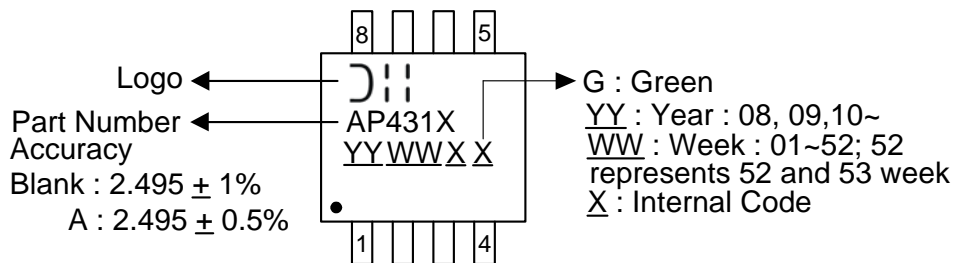

Logo
Part Number
Accuracy
Blank : 2.495 ± 1%
A : 2.495 ± 0.5%

G : Green
YY : Year : 08, 09, 10~
WW : Week : 01~52; 52
represents 52 and 53 week
X : Internal Code

Marking Information (cont.)

(5) SOT89

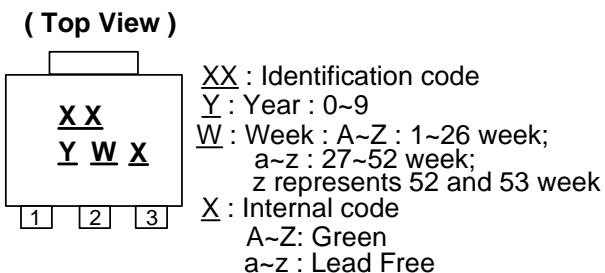

(6) TO92

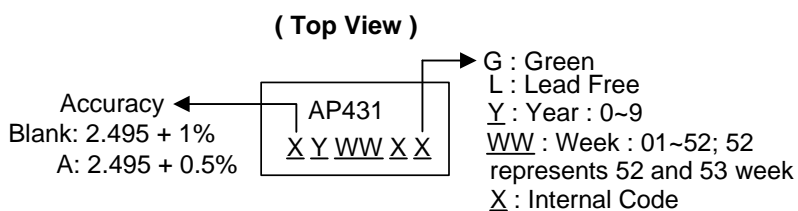

Identification Code Table

| Device | Package (Note 11) | Identification Code | Date Code |
|----------|-------------------|---------------------|-----------|
| AP431SA | SOT23 | D1 | YM |
| AP431ASA | SOT23 | D2 | YM |
| AP431SR | SOT23R | D5 | YM |
| AP431ASR | SOT23R | D6 | YM |
| AP431Q | SOT25 | A2 | YM |
| AP431AQ | SOT25 | A3 | YM |
| AP431W | SC59 | A6 | YM |
| AP431AW | SC59 | A7 | YM |
| AP431R | SC59 | A8 | YM |
| AP431AR | SC59 | A9 | YM |
| AP431Y | SOT89 | A4 | YM |
| AP431AY | SOT89 | A5 | YM |

Notes: 11. For Packaging Details, go to our website at <http://www.diodes.com/datasheets/ap02007.pdf>.

Package Outline Dimensions (All dimensions in mm.)

Please see AP02002 at <http://www.diodes.com/datasheets/ap02002.pdf> for latest version.

(1) SOT25

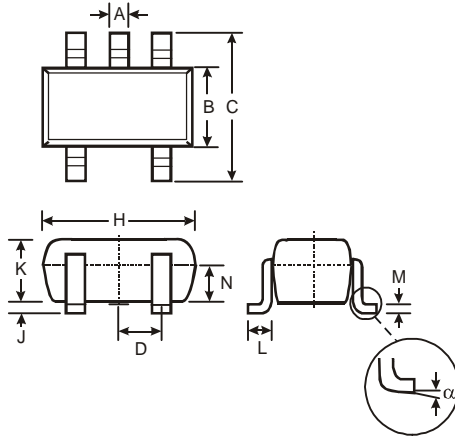

| SOT25 | | | |
|----------------------|-------|------|------|
| Dim | Min | Max | Typ |
| A | 0.35 | 0.50 | 0.38 |
| B | 1.50 | 1.70 | 1.60 |
| C | 2.70 | 3.00 | 2.80 |
| D | — | — | 0.95 |
| H | 2.90 | 3.10 | 3.00 |
| J | 0.013 | 0.10 | 0.05 |
| K | 1.00 | 1.30 | 1.10 |
| L | 0.35 | 0.55 | 0.40 |
| M | 0.10 | 0.20 | 0.15 |
| N | 0.70 | 0.80 | 0.75 |
| α | 0° | 8° | — |
| All Dimensions in mm | | | |

(2) SO-8

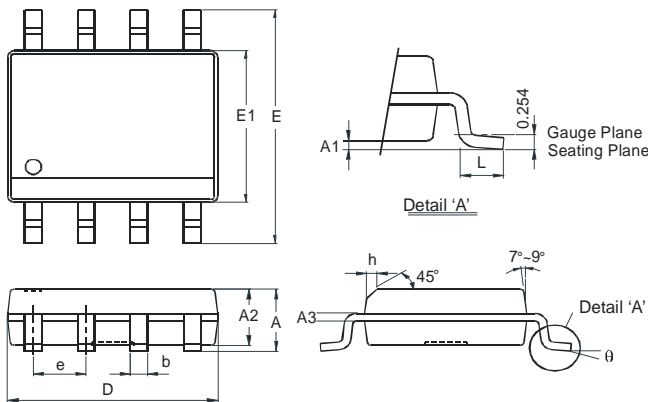

| SO-8 | | |
|----------------------|----------|------|
| Dim | Min | Max |
| A | - | 1.75 |
| A1 | 0.10 | 0.20 |
| A2 | 1.30 | 1.50 |
| A3 | 0.15 | 0.25 |
| b | 0.3 | 0.5 |
| D | 4.85 | 4.95 |
| E | 5.90 | 6.10 |
| E1 | 3.85 | 3.95 |
| e | 1.27 Typ | |
| h | - | 0.35 |
| L | 0.62 | 0.82 |
| θ | 0° | 8° |
| All Dimensions in mm | | |

(3) SC59 and SC59R

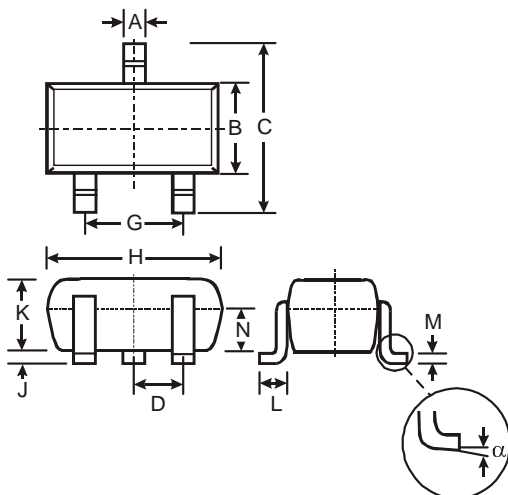

| SC59 | | | |
|----------------------|-------|------|------|
| Dim | Min | Max | Typ |
| A | 0.35 | 0.50 | 0.38 |
| B | 1.50 | 1.70 | 1.60 |
| C | 2.70 | 3.00 | 2.80 |
| D | - | - | 0.95 |
| G | - | - | 1.90 |
| H | 2.90 | 3.10 | 3.00 |
| J | 0.013 | 0.10 | 0.05 |
| K | 1.00 | 1.30 | 1.10 |
| L | 0.35 | 0.55 | 0.40 |
| M | 0.10 | 0.20 | 0.15 |
| N | 0.70 | 0.80 | 0.75 |
| α | 0° | 8° | - |
| All Dimensions in mm | | | |

Package Outline Dimensions (cont.) (All dimensions in mm.)

Please see AP02002 at <http://www.diodes.com/datasheets/ap02002.pdf> for latest version.

(4) SOT23 and SOT23R

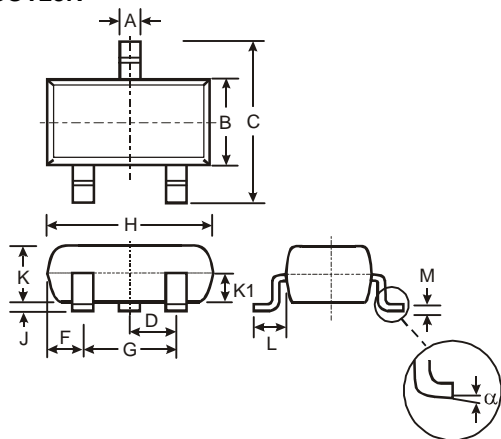

| SOT23 | | | |
|----------------------|-------|------|-------|
| Dim | Min | Max | Typ |
| A | 0.37 | 0.51 | 0.40 |
| B | 1.20 | 1.40 | 1.30 |
| C | 2.30 | 2.50 | 2.40 |
| D | 0.89 | 1.03 | 0.915 |
| F | 0.45 | 0.60 | 0.535 |
| G | 1.78 | 2.05 | 1.83 |
| H | 2.80 | 3.00 | 2.90 |
| J | 0.013 | 0.10 | 0.05 |
| K | 0.903 | 1.10 | 1.00 |
| K1 | - | - | 0.400 |
| L | 0.45 | 0.61 | 0.55 |
| M | 0.085 | 0.18 | 0.11 |
| α | 0° | 8° | - |
| All Dimensions in mm | | | |

(5) SOT89

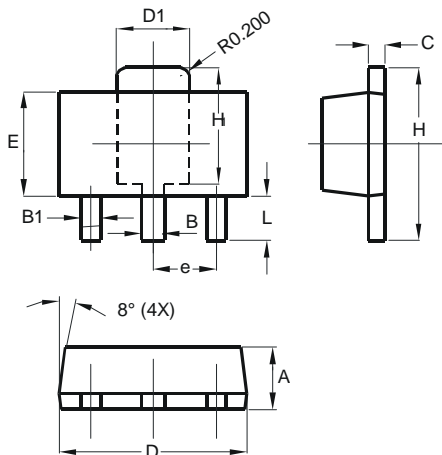

| SOT89 | | |
|----------------------|----------|------|
| Dim | Min | Max |
| A | 1.40 | 1.60 |
| B | 0.44 | 0.62 |
| B1 | 0.35 | 0.54 |
| C | 0.35 | 0.44 |
| D | 4.40 | 4.60 |
| D1 | 1.62 | 1.83 |
| E | 2.29 | 2.60 |
| e | 1.50 Typ | |
| H | 3.94 | 4.25 |
| H1 | 2.63 | 2.93 |
| L | 0.89 | 1.20 |
| All Dimensions in mm | | |

(6) TO92

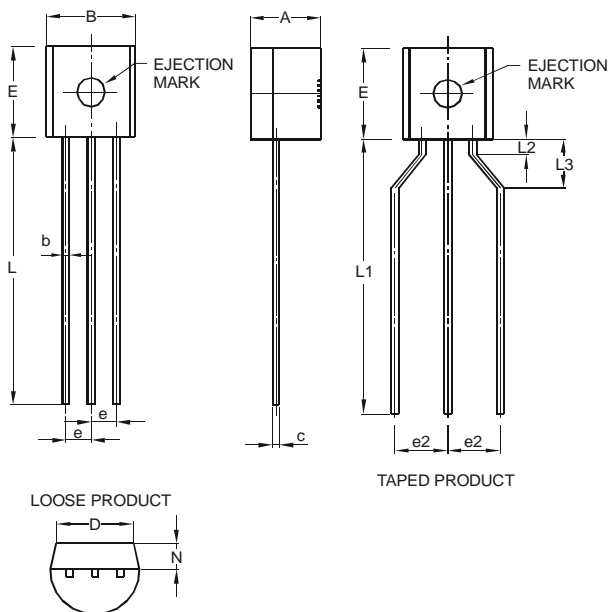

| TO92 | | | |
|----------------------|-------|-------|------|
| Dim | Min | Max | Typ |
| A | 3.45 | 3.66 | — |
| B | 4.27 | 4.78 | — |
| b | — | — | 0.38 |
| c | — | — | 0.38 |
| D | — | — | 3.87 |
| E | 4.32 | 4.83 | — |
| e | — | — | 1.27 |
| e2 | 2.40 | 2.90 | — |
| L | 12.98 | 15.00 | — |
| L1 | 12.80 | 15.00 | — |
| L2 | 0.80 | — | — |
| L3 | 2.00 | 3.00 | — |
| N | 1.22 | 1.37 | — |
| All Dimensions in mm | | | |

Suggested Pad Layout

Please see AP02001 at <http://www.diodes.com/datasheets/ap02001.pdf> for the latest version.

(1) SOT25

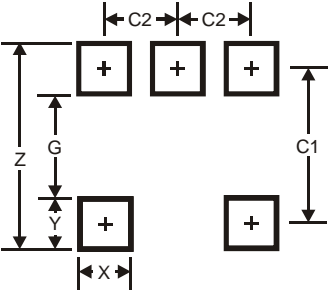

| Dimensions | Value (in mm) |
|------------|---------------|
| Z | 3.20 |
| G | 1.60 |
| X | 0.55 |
| Y | 0.80 |
| C1 | 2.40 |
| C2 | 0.95 |

(2) SO-8

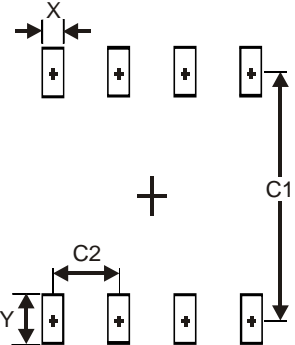

| Dimensions | Value (in mm) |
|------------|---------------|
| X | 0.60 |
| Y | 1.55 |
| C1 | 5.4 |
| C2 | 1.27 |

(3) SC59 and SC59R

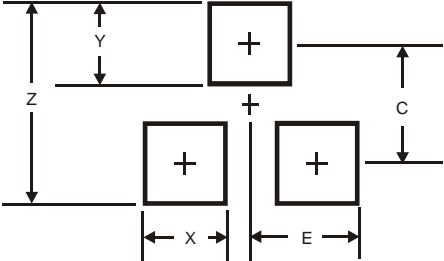

| Dimensions | Value (in mm) |
|------------|---------------|
| Z | 3.4 |
| X | 0.8 |
| Y | 1.0 |
| C | 2.4 |
| E | 1.35 |

Suggested Pad Layout (cont.)

Please see AP02001 at <http://www.diodes.com/datasheets/ap02001.pdf> for the latest version.

(4) SOT23 and SOT23R

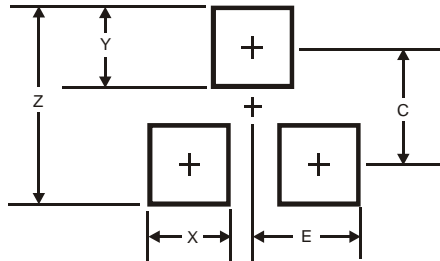

| Dimensions | Value (in mm) |
|------------|---------------|
| Z | 2.9 |
| X | 0.8 |
| Y | 0.9 |
| C | 2.0 |
| E | 1.35 |

(5) SOT89

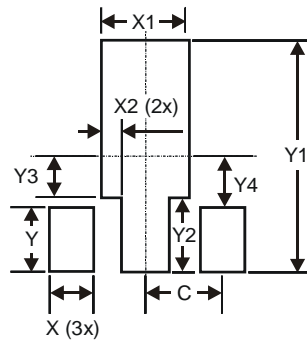

| Dimensions | Value (in mm) |
|------------|---------------|
| X | 0.900 |
| X1 | 1.733 |
| X2 | 0.416 |
| Y | 1.300 |
| Y1 | 4.600 |
| Y2 | 1.475 |
| Y3 | 0.950 |
| Y4 | 1.125 |
| C | 1.500 |

IMPORTANT NOTICE

DIODES INCORPORATED MAKES NO WARRANTY OF ANY KIND, EXPRESS OR IMPLIED, WITH REGARDS TO THIS DOCUMENT, INCLUDING, BUT NOT LIMITED TO, THE IMPLIED WARRANTIES OF MERCHANTABILITY AND FITNESS FOR A PARTICULAR PURPOSE (AND THEIR EQUIVALENTS UNDER THE LAWS OF ANY JURISDICTION).

Diodes Incorporated and its subsidiaries reserve the right to make modifications, enhancements, improvements, corrections or other changes without further notice to this document and any product described herein. Diodes Incorporated does not assume any liability arising out of the application or use of this document or any product described herein; neither does Diodes Incorporated convey any license under its patent or trademark rights, nor the rights of others. Any Customer or user of this document or products described herein in such applications shall assume all risks of such use and will agree to hold Diodes Incorporated and all the companies whose products are represented on Diodes Incorporated website, harmless against all damages.

Diodes Incorporated does not warrant or accept any liability whatsoever in respect of any products purchased through unauthorized sales channel.

Should Customers purchase or use Diodes Incorporated products for any unintended or unauthorized application, Customers shall indemnify and hold Diodes Incorporated and its representatives harmless against all claims, damages, expenses, and attorney fees arising out of, directly or indirectly, any claim of personal injury or death associated with such unintended or unauthorized application.

Products described herein may be covered by one or more United States, international or foreign patents pending. Product names and markings noted herein may also be covered by one or more United States, international or foreign trademarks.

LIFE SUPPORT

Diodes Incorporated products are specifically not authorized for use as critical components in life support devices or systems without the express written approval of the Chief Executive Officer of Diodes Incorporated. As used herein:

A. Life support devices or systems are devices or systems which:

1. are intended to implant into the body, or
2. support or sustain life and whose failure to perform when properly used in accordance with instructions for use provided in the labeling can be reasonably expected to result in significant injury to the user.

B. A critical component is any component in a life support device or system whose failure to perform can be reasonably expected to cause the failure of the life support device or to affect its safety or effectiveness.

Customers represent that they have all necessary expertise in the safety and regulatory ramifications of their life support devices or systems, and acknowledge and agree that they are solely responsible for all legal, regulatory and safety-related requirements concerning their products and any use of Diodes Incorporated products in such safety-critical, life support devices or systems, notwithstanding any devices- or systems-related information or support that may be provided by Diodes Incorporated. Further, Customers must fully indemnify Diodes Incorporated and its representatives against any damages arising out of the use of Diodes Incorporated products in such safety-critical, life support devices or systems.

Copyright © 2012, Diodes Incorporated

www.diodes.com