

Features

- 500mW Power Dissipation
- General Purpose, Medium Current
- Ideally Suited for Automated Assembly Processes
- **Lead, Halogen and Antimony Free, RoHS Compliant (Note 1)**
- **"Green" Device (Note 2)**
- **Qualified to AEC-Q101 Standards for High Reliability**

Mechanical Data

- Case: SOD123
- Case Material: Molded Plastic, "Green" Molding Compound. UL Flammability Classification Rating 94V-0
- Moisture Sensitivity: Level 1 per J-STD-020
- Terminals: Matte Tin Finish annealed over Alloy 42 leadframe (Lead Free Plating). Solderable per MIL-STD-202, Method 208
- Polarity: Cathode Band
- Weight: 0.01 grams (approximate)



Top View

Ordering Information (Note 3)

Part Number	Qualification	Case	Packaging
(Type Number)-7-F*	Commercial	SOD123	3000/Tape & Reel
(Type Number)Q-7-F*	Automotive	SOD123	3000/Tape & Reel
(Type Number)-13-F*	Commercial	SOD123	10000/Tape & Reel
(Type Number)Q-13-F*	Automotive	SOD123	10000/Tape & Reel

*For (Type Number), please see the Electrical Characteristics Table. Example: 6.2V Zener = MMSZ5234B-7-F.

- Notes:
1. No purposefully added lead. Halogen and Antimony Free.
 2. Product manufactured with Date Code V9 (week 33, 2008) and newer are built with Green Molding Compound. Product manufactured prior to Date Code V9 are built with Non-Green Molding Compound and may contain Halogens or Sb₂O₃ Fire Retardants.
 3. For packaging details, go to our website at <http://www.diodes.com>.

Marking Information

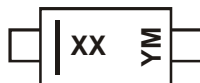

xx = Product Type Marking Code
(See Electrical Characteristics Table)
YM = Date Code Marking
Y = Year (ex: N = 2002)
M = Month (ex: 9 = September)

Date Code Key

Year	1998	1999	2000	2001	2002	2003	2004	2005	2006	2007	2008	2009	2010	2011	2012	2013	2014	2015
Code	J	K	L	M	N	P	R	S	T	U	V	W	X	Y	Z	A	B	C
Month	Jan	Feb	Mar	Apr	May	Jun	Jul	Aug	Sep	Oct	Nov	Dec						
Code	1	2	3	4	5	6	7	8	9	O	N	D						

Maximum Ratings @T_A = 25°C unless otherwise specified

Characteristic	Symbol	Value	Unit
Forward Voltage @ I _F = 10mA	V _F	0.9	V

Thermal Characteristics

Characteristic	Symbol	Value	Unit
Power Dissipation (Note 4) @T _L = 75°C	P _D	500	mW
Thermal Resistance, Junction to Ambient Air (Note 4)	R _{θJA}	350	°C/W
Thermal Resistance, Junction to Lead (Note 5)	R _{θJL}	150	°C/W
Operating and Storage Temperature Range	T _J , T _{STG}	-65 to +150	°C

Electrical Characteristics @T_A = 25°C unless otherwise specified

Type Number	Type Code	Zener Voltage Range (Note 6)			Test Current	Maximum Zener Impedance f = 1KHz		Maximum Reverse Leakage Current (Note 6)	
		V _Z @ I _{ZT}				I _{ZT}	Z _{ZT} @ I _{ZT}	Z _{ZK} @ I _{ZK} = 0.25mA	I _R
		Nom (V)	Min (V)	Max (V)	mA	Ω		μA	V
MMSZ5221B	C1	2.4	2.28	2.52	20	30	1200	100	1.0
MMSZ5223B	C3	2.7	2.57	2.84	20	30	1300	75	1.0
MMSZ5225B	C5	3.0	2.85	3.15	20	30	1600	50	1.0
MMSZ5226B	G1	3.3	3.14	3.47	20	28	1600	25	1.0
MMSZ5227B	G2	3.6	3.42	3.78	20	24	1700	15	1.0
MMSZ5228B	G3	3.9	3.71	4.10	20	23	1900	10	1.0
MMSZ5229B	G4	4.3	4.09	4.52	20	22	2000	5.0	1.0
MMSZ5230B	G5	4.7	4.47	4.94	20	19	1900	5.0	2.0
MMSZ5231B	E1	5.1	4.85	5.36	20	17	1600	5.0	2.0
MMSZ5232B	E2	5.6	5.32	5.88	20	11	1600	5.0	3.0
MMSZ5233B	E3	6.0	5.70	6.30	20	7	1600	5.0	3.5
MMSZ5234B	E4	6.2	5.89	6.51	20	7	1000	5.0	4.0
MMSZ5235B	E5	6.8	6.46	7.14	20	5	750	3.0	5.0
MMSZ5236B	F1	7.5	7.13	7.88	20	6	500	3.0	6.0
MMSZ5237B	F2	8.2	7.79	8.61	20	8	500	3.0	6.5
MMSZ5238B	F3	8.7	8.27	9.14	20	8	600	3.0	6.5
MMSZ5239B	F4	9.1	8.65	9.56	20	10	600	3.0	7.0
MMSZ5240B	F5	10	9.50	10.50	20	17	600	3.0	8.0
MMSZ5241B	H1	11	10.45	11.55	20	22	600	2.0	8.4
MMSZ5242B	H2	12	11.40	12.60	20	30	600	1.0	9.1
MMSZ5243B	H3	13	12.35	13.65	9.5	13	600	0.5	9.9
MMSZ5245B	H5	15	14.25	15.75	8.5	16	600	0.1	11
MMSZ5246B	J1	16	15.20	16.80	7.8	17	600	0.1	12
MMSZ5248B	J3	18	17.10	18.90	7.0	21	600	0.1	14
MMSZ5250B	J5	20	19.00	21.00	6.2	25	600	0.1	15
MMSZ5251B	K1	22	20.90	23.10	5.6	29	600	0.1	17
MMSZ5252B	K2	24	22.80	25.20	5.2	33	600	0.1	18
MMSZ5254B	K4	27	25.65	28.35	5.0	41	600	0.1	21
MMSZ5255B	K5	28	26.60	29.40	4.5	44	600	0.1	21
MMSZ5256B	M1	30	28.50	31.50	4.2	49	600	0.1	23
MMSZ5257B	M2	33	31.35	34.65	3.8	58	700	0.1	25
MMSZ5258B	M3	36	34.20	37.80	3.4	70	700	0.1	27
MMSZ5259B	M4	39	37.05	40.95	3.2	80	800	0.1	30

Notes: 4. Device mounted on FR-4 substrate, single-sided, PC boards, with minimum recommended pad layout.
5. Thermal Resistance measurement obtained via infrared scan method.
6. Short duration pulse test used to minimize self-heating effect.

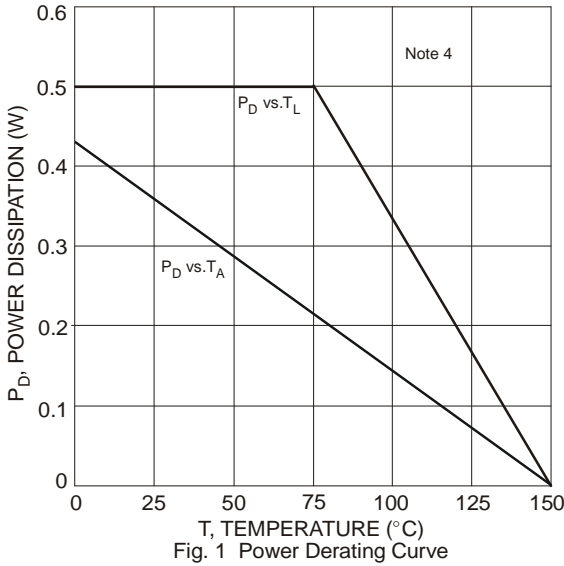

Fig. 1 Power Derating Curve

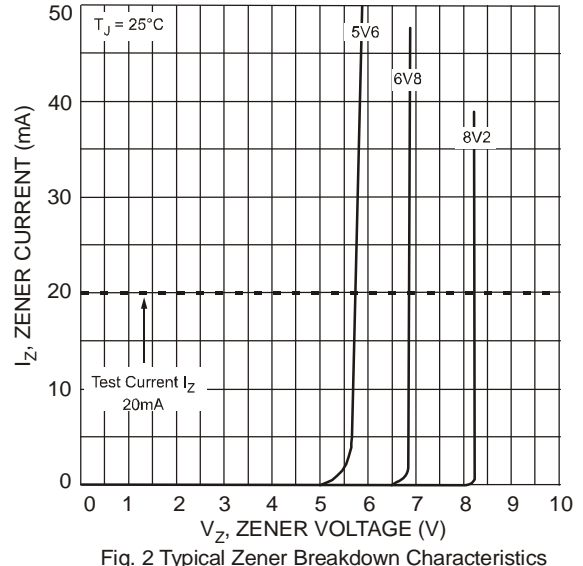

Fig. 2 Typical Zener Breakdown Characteristics

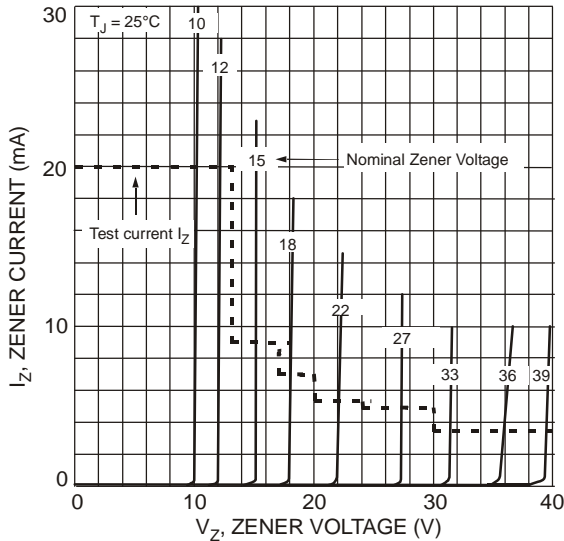

Fig. 3 Typical Zener Breakdown Characteristics

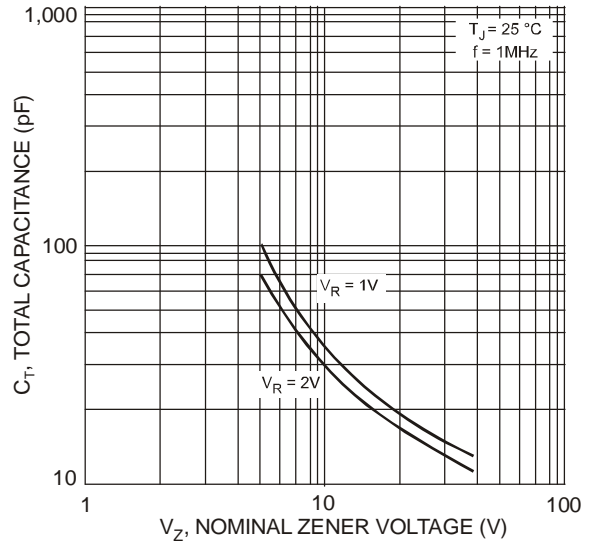

Fig. 4 Typical Total Capacitance vs. Nominal Zener Voltage

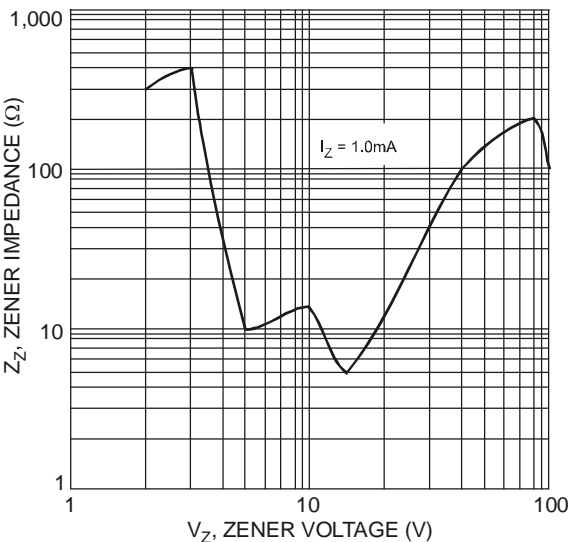

Fig. 5 Typical Zener Impedance Characteristics

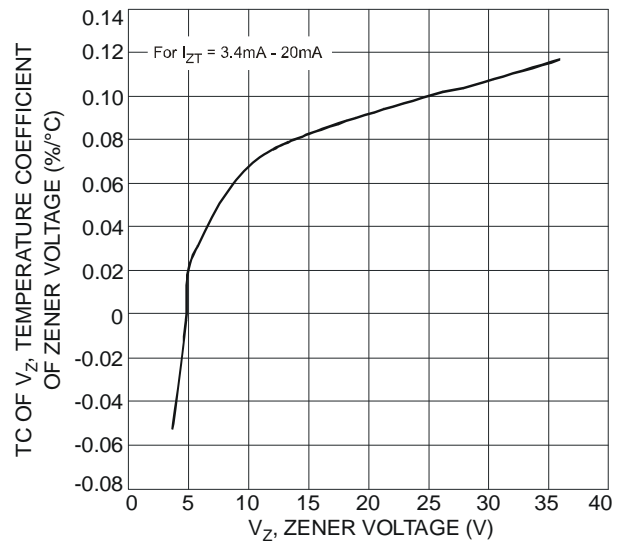
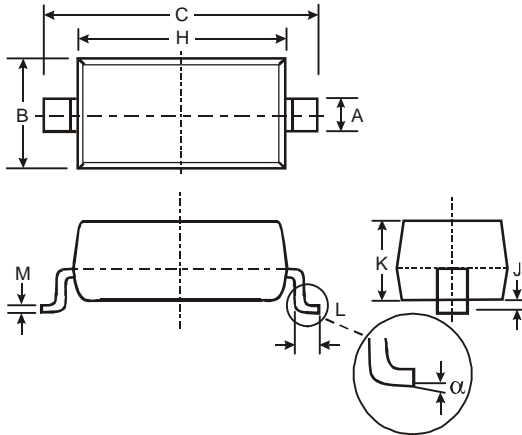

Fig. 6 Typical Temperature Coefficient of Zener Voltage vs. Zener Voltage (MMSZ5227B - MMSZ5258B)

Package Outline Dimensions



SOD123		
Dim	Min	Max
A	0.55 Typ	
B	1.40	1.70
C	3.55	3.85
H	2.55	2.85
J	0.00	0.10
K	1.00	1.35
L	0.25	0.40
M	0.10	0.15
α	0	8°
All Dimensions in mm		

Suggested Pad Layout

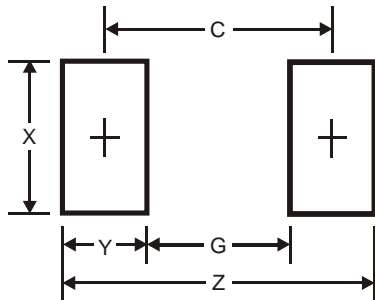

Dimensions	Value (in mm)
Z	4.9
G	2.5
X	0.7
Y	1.2
C	3.7

IMPORTANT NOTICE

DIODES INCORPORATED MAKES NO WARRANTY OF ANY KIND, EXPRESS OR IMPLIED, WITH REGARDS TO THIS DOCUMENT, INCLUDING, BUT NOT LIMITED TO, THE IMPLIED WARRANTIES OF MERCHANTABILITY AND FITNESS FOR A PARTICULAR PURPOSE (AND THEIR EQUIVALENTS UNDER THE LAWS OF ANY JURISDICTION).

Diodes Incorporated and its subsidiaries reserve the right to make modifications, enhancements, improvements, corrections or other changes without further notice to this document and any product described herein. Diodes Incorporated does not assume any liability arising out of the application or use of this document or any product described herein; neither does Diodes Incorporated convey any license under its patent or trademark rights, nor the rights of others. Any Customer or user of this document or products described herein in such applications shall assume all risks of such use and will agree to hold Diodes Incorporated and all the companies whose products are represented on Diodes Incorporated website, harmless against all damages.

Diodes Incorporated does not warrant or accept any liability whatsoever in respect of any products purchased through unauthorized sales channel. Should Customers purchase or use Diodes Incorporated products for any unintended or unauthorized application, Customers shall indemnify and hold Diodes Incorporated and its representatives harmless against all claims, damages, expenses, and attorney fees arising out of, directly or indirectly, any claim of personal injury or death associated with such unintended or unauthorized application.

Products described herein may be covered by one or more United States, international or foreign patents pending. Product names and markings noted herein may also be covered by one or more United States, international or foreign trademarks.

LIFE SUPPORT

Diodes Incorporated products are specifically not authorized for use as critical components in life support devices or systems without the express written approval of the Chief Executive Officer of Diodes Incorporated. As used herein:

A. Life support devices or systems are devices or systems which:

1. are intended to implant into the body, or
2. support or sustain life and whose failure to perform when properly used in accordance with instructions for use provided in the labeling can be reasonably expected to result in significant injury to the user.

B. A critical component is any component in a life support device or system whose failure to perform can be reasonably expected to cause the failure of the life support device or to affect its safety or effectiveness.

Customers represent that they have all necessary expertise in the safety and regulatory ramifications of their life support devices or systems, and acknowledge and agree that they are solely responsible for all legal, regulatory and safety-related requirements concerning their products and any use of Diodes Incorporated products in such safety-critical, life support devices or systems, notwithstanding any devices- or systems-related information or support that may be provided by Diodes Incorporated. Further, Customers must fully indemnify Diodes Incorporated and its representatives against any damages arising out of the use of Diodes Incorporated products in such safety-critical, life support devices or systems.

Copyright © 2011, Diodes Incorporated

www.diodes.com