

Silicon Low Leakage Diode Array

- Low-leakage applications
- Medium speed switching times
- Common cathode

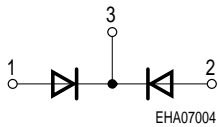
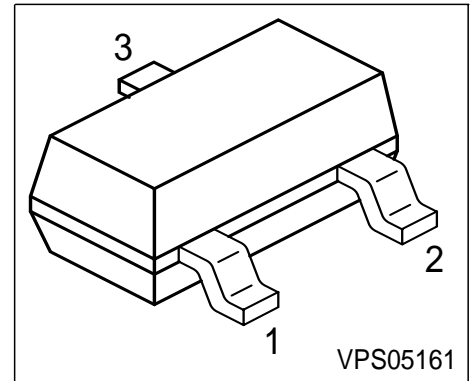

Type	Marking	Pin Configuration			Package
BAV170	JXs	1 = A1	2 = A2	3 = C1/2	SOT23

Maximum Ratings

Parameter	Symbol	Value	Unit
Diode reverse voltage	V_R	70	V
Peak reverse voltage-	V_{RM}	70	
Forward current	I_F	200	mA
Surge forward current, $t = 1 \mu s$	I_{FS}	4.5	A
Total power dissipation $T_S = 35 \text{ }^\circ\text{C}$	P_{tot}	250	mW
Junction temperature	T_j	150	$^\circ\text{C}$
Storage temperature	T_{stg}	-65 ... 150	

Thermal Resistance

Parameter	Symbol	Value	Unit
Junction - soldering point ¹⁾	R_{thJS}	≤ 460	K/W

¹For calculation of R_{thJA} please refer to Application Note Thermal Resistance

Electrical Characteristics at $T_A = 25^\circ\text{C}$, unless otherwise specified

Parameter	Symbol	Values			Unit
		min.	typ.	max.	
DC Characteristics					
Breakdown voltage $I_{(BR)} = 100 \mu\text{A}$	$V_{(BR)}$	70	-	-	V
Reverse current $V_R = 70 \text{ V}$ $V_R = 70 \text{ V}, T_A = 150 \text{ }^\circ\text{C}$	I_R	-	-	5 80	nA
Forward voltage $I_F = 1 \text{ mA}$ $I_F = 10 \text{ mA}$ $I_F = 50 \text{ mA}$ $I_F = 150 \text{ mA}$	V_F	-	-	900 1000 1100 1250	mV

AC Characteristics

Diode capacitance- $V_R = 0 \text{ V}, f = 1 \text{ MHz}$	C_T	-	2	-	pF
Reverse recovery time $I_F = 10 \text{ mA}, I_R = 10 \text{ mA}$, measured at $I_R = 1 \text{ mA}$, $R_L = 100 \Omega$	t_{rr}	-	0.5	3	μs

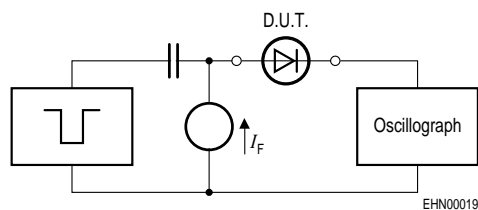
Test circuit for reverse recovery time

Puls generator: $t_p = 10 \mu\text{s}$, $D = 0.05$,
 $t_f = 0.6 \text{ ns}$, $R_i = 50 \Omega$

Oscillograph: $R = 50 \Omega$, $t_f = 0.35 \text{ ns}$,
 $C \leq 1 \text{ pF}$

Reverse current $I_R = f(T_A)$

$V_R = 70\text{ V}$

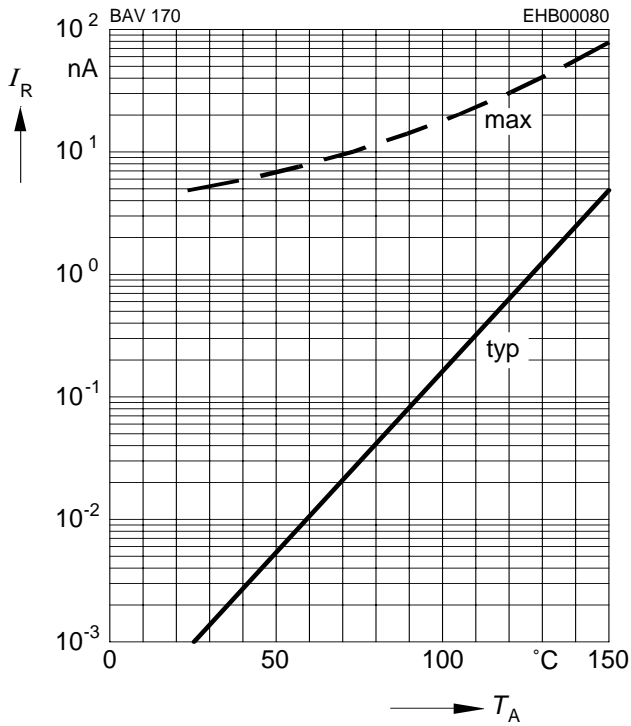

Forward Voltage $V_F = f(T_A)$

$I_F = \text{Parameter}$

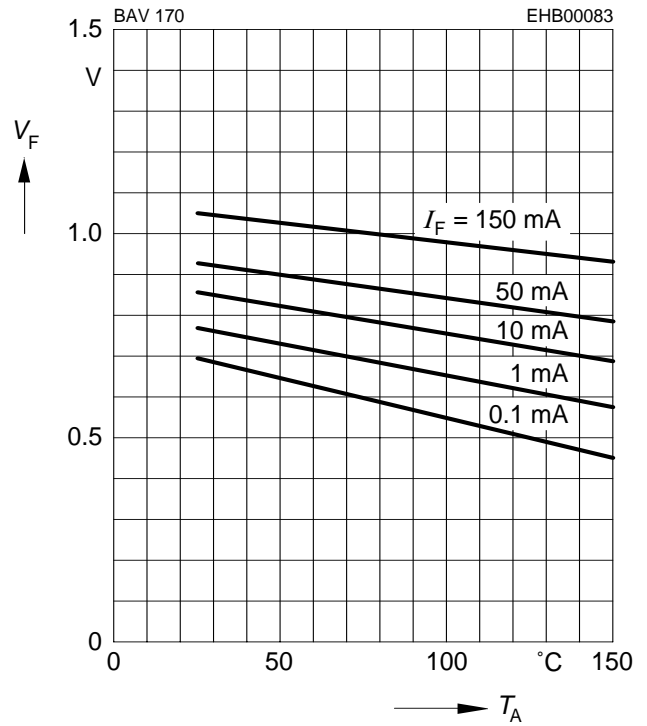

Forward current $I_F = f(T_S)$

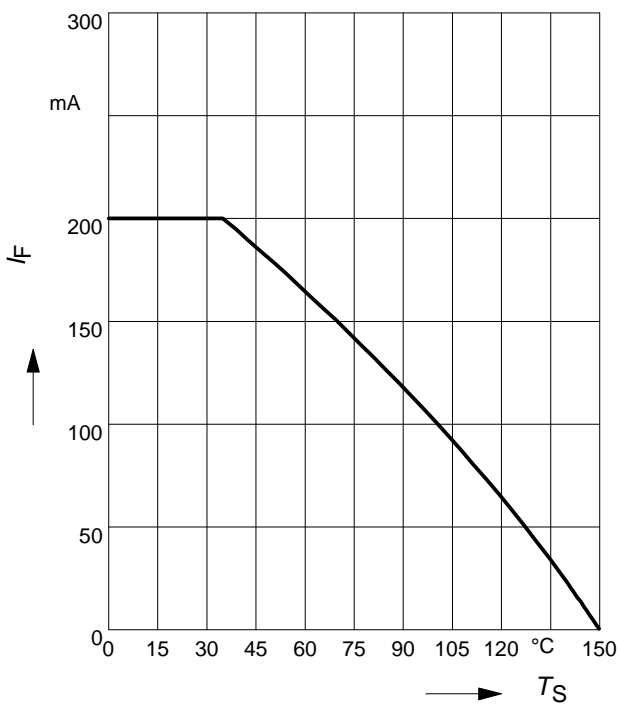

Forward current $I_F = f(V_F)$

$T_A = 25\text{ °C}$

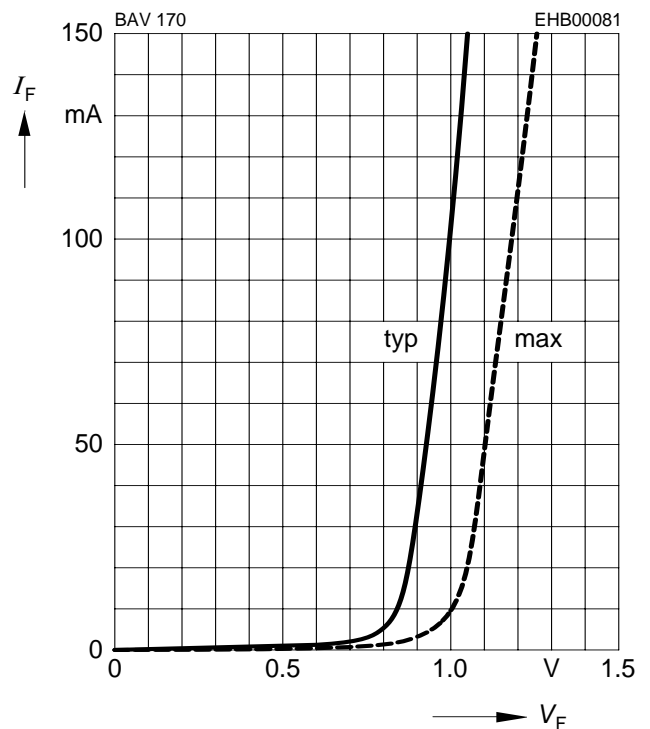

Peak forward current $I_{FM} = f(t_p)$

$T_A = 25\text{ °C}$

