

Device Overview

The RC32336 device is a member of the IDT™ Enterprise™ family of integrated communications processors. It provides an effective solution for small office/home office (SOHO) applications including gateways and both single-band and dual-band wireless access points. Featuring a MIPS compatible CPU core, the device also includes a memory controller supporting SDRAM memory, a PCI interface featuring an on-chip arbiter to support up to three external devices, a PCMCIA interface that supports a single I/O device, and two integrated on-chip 10/100 Ethernet MACs to enable WAN and LAN connectivity.

The key features of the RC32336 enable SOHO applications at unmatched price/performance points. The MIPS-compatible CPU core has the required bandwidth to enable a WAP application with the latest wireless security protocols, WPA and 802.11i, which include the enterprise-level user authentication schemes 802.1x and Extensible Authentication Protocol (EAP). The ability to connect and support the bandwidth requirements of one or two WLAN modules is made possible by the high bandwidth PCI and PCMCIA interfaces. Also, the device has been architected to provide high speed LAN to WAN routing bandwidth through the Ethernet MACs while simultaneously driving data through the other on-chip interfaces.

Features List

- ◆ **RC32300 32-bit CPU core**
 - 32-bit MIPS instruction set
 - Supports big or little endian operation

- **MMU**
 - 16-entry TLB
 - Supports variable page sizes and enhanced write algorithm
 - Supports variable number of locked entries
- **8KB Instruction Cache**
 - 2-way set associative
 - LRU replacement algorithm
 - 4 word line size
 - Sub-block ordering
 - Word parity
 - Per line cache locking
- **2KB Data Cache**
 - 2-way set associative
 - LRU replacement algorithm
 - 4 word line size
 - Sub-block ordering
 - Byte parity
 - Per line cache locking
 - Can be programmed on a page basis to implement write-through no write allocate, write-through write allocate, or write-back algorithms
- **Enhanced EJTAG and JTAG Interfaces**
 - Compatible with IEEE Std. 1149.1-1990

Block Diagram

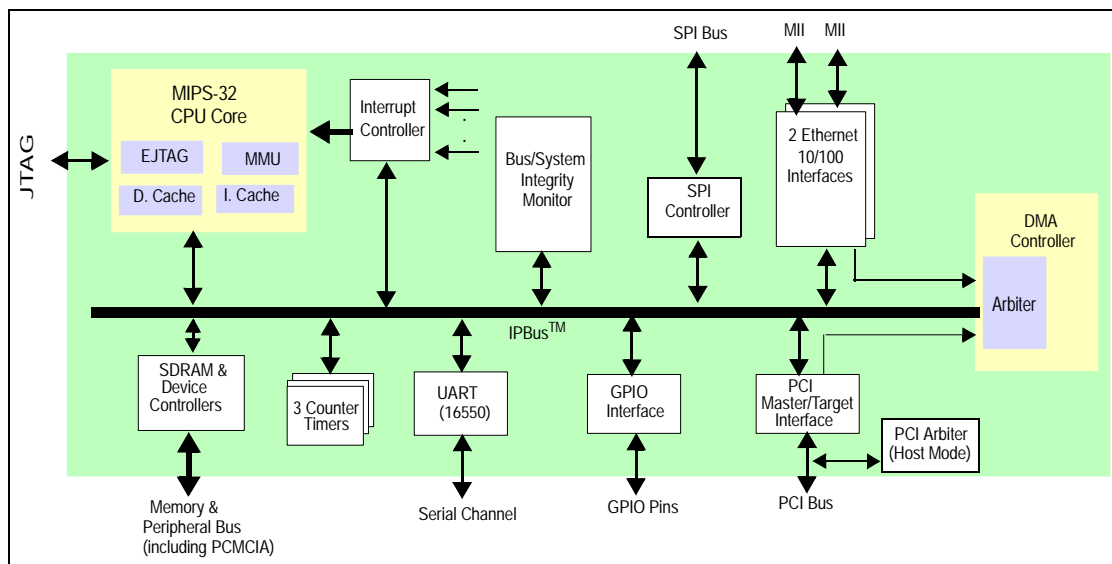

Figure 1 RC32336 Internal Block Diagram

◆ PCI Interface

- 32-bit PCI revision 2.2 compliant
- Supports host or satellite operation in both master and target modes
- PCI clock: supports frequencies from 16 MHz to 66 MHz, PCI clock may be asynchronous to master clock (CLK)
- PCI arbiter in Host mode: supports 3 external masters, fixed priority or round robin arbitration
- I₂O "like" PCI Messaging Unit

◆ Two Ethernet Interfaces

- 10 and 100 Mb/s ISO/IEC 8802-3:1996 compliant
- Two IEEE 802.3u compatible Media Independent Interfaces (MII) with serial management interface
- MII supports IEEE 802.3u auto-negotiation speed selection
- Supports 64 entry hash table based multicast address filtering
- 512 byte transmit and receive FIFOs
- Supports flow control functions outlined in IEEE Std. 802.3x-1997

◆ SDRAM Controller

- Supports up to 512 MB of memory
- 2 chip selects (each supports 2 or 4 banks internal SDRAM banks)
- 32-bit data width, supports 8/16/32-bit width devices
- Supports 16Mb, 64Mb, 128Mb, and 256Mb, and 512Mb devices
- Automatic refresh generation

◆ Memory and Peripheral Device Controller

- Provides "glueless" interface to standard SRAM, Flash, ROM, dual-port memory, and peripheral devices
- Provides "glueless" interface to many 16-bit PCMCIA devices
- Demultiplexed address and data buses: 32-bit data bus, 26-bit address bus, 6 chip selects, control for external data bus buffers
- Supports 8-bit, 16-bit, and 32-bit width devices: automatic byte gathering and scattering
- Flexible protocol configuration parameters: programmable number of wait states (0 to 63), programmable postread/post-write delay (0 to 31), supports external wait state generation, supports Intel and Motorola style peripherals
- Write protect capability per chip select
- Programmable bus transaction timer generates warm reset when counter expires
- Supports up to 64MB of memory per chip select

◆ DMA Controller

- 6 DMA channels: two channels for each of the two Ethernet interfaces (transmit/receive) and two channels for PCI (PCI to Memory and Memory to PCI)
- Provides flexible descriptor based operation
- Supports unaligned transfers (i.e., source or destination address may be on any byte boundary) with arbitrary byte length

◆ General Purpose Peripherals

- Serial port compatible with 16550 Universal Asynchronous Receiver Transmitter (UART)
- Three general purpose 32-bit counter/timers
- Interrupt Controller
- Serial Peripheral Interface (SPI) supporting host mode
- 16 general purpose I/O (GPIO) pins which can be configured as interrupt sources

◆ System Features

- JTAG Interface (IEEE Std. 1149.1 compatible)
- 256 pin CABGA package
- 2.5V core supply and 3.3V I/O supply

CPU Execution Core

The RC32336 is built around the RC32300 32-bit high performance microprocessor core. The RC32300 implements the enhanced MIPS-II ISA and helps meet the real-time goals and maximize throughput of communications and consumer systems by providing capabilities such as a prefetch instruction, multiple DSP instructions, and cache locking. The instruction set is largely compatible with the MIPS32 instruction set, allowing the customer to select from a broad range of software and development tools. Cache locking guarantees real-time performance by holding critical code and parameters in the cache for immediate availability. The microprocessor also implements an on-chip MMU with a TLB, making it fully compliant with the requirements of real time operating systems.

PCI Interface

The PCI interface on the RC32336 is compatible with version 2.2 of the PCI specification. An on-chip arbiter supports up to three external bus masters, supporting both fixed priority and rotating priority arbitration schemes. The RC32336 can support both satellite and host PCI configurations, enabling it to act as a slave controller for a PCI add-in card application, or as the primary PCI controller in the system. The PCI interface can be operated synchronously or asynchronously to the other I/O interfaces on the RC32336 device.

PCMCIA Interface

The RC32336 provides a "glueless" connection to a single PCMCIA I/O device via the memory and peripheral device controller. The PCMCIA interface allows the RC32336 to connect to various types of I/O peripherals including fax modems, storage devices, and wireless LAN chipsets. The RC32336 implementation provides a maximum throughput of 160 Mbps through the 16-bit wide interface as specified by the PCMCIA 2.1 Standard.

Ethernet Interface

The RC32336 has two Ethernet Channels supporting 10Mbps and 100Mbps speeds and provides a standard media independent interface (MII) off-chip, allowing a wide range of external devices to be connected efficiently.

Memory and I/O Controller

The RC32336 incorporates a flexible memory and peripheral device controller providing direct support for SDRAM, Flash ROM, SRAM, PCMCIA, and other I/O devices. It can interface directly to 8-bit boot ROM for a very low cost system implementation. It also offers various trade-offs in cost / performance for the main memory architecture. The timers implemented on the RC32336 satisfy the requirements of most real time operating systems.

DMA Controller

The DMA controller off-loads the CPU core from moving data among the on-chip interfaces, external peripherals, and memory. The DMA controller supports scatter / gather DMA with no alignment restrictions, appropriate for communications and graphics systems.

Enhanced JTAG Interface

For system debugging, the RC32300 CPU core includes an Enhanced JTAG (EJTAG) interface which operates in Run-Time Mode.

Thermal Considerations

The RC32336 is guaranteed in a ambient temperature range of 0° to +70° C for commercial temperature devices and - 40° to +85° for industrial temperature devices.

Revision History

July 9, 2003: Initial publication.

October 3, 2003: Changed min values in Table 7 from 1.8 to 1.2 for all signals except SDCLKINP and SDCKENP. Changed min values for Tdo 10b and 10c in Table 10 for PCIBEN, etc. and PCIGNTN/PCIREQN from 2.0 to 1.5.

May 25, 2004: In Table 9, signals MIIXRXCLK and MIIXTXCLK, the Min and Max values for Thigh/Tlow_9c were changed to 140 and 260 respectively and the Min and Max values for Thigh/Tlow_9d were changed to 14.0 and 26.0 respectively.

October 4, 2005: Changed 180MHz to 150MHz speed grade with corresponding values.

Pin Description Table

The following table lists the functions of the pins provided on the RC32336. Some of the functions listed may be multiplexed onto the same pin (indicated as alternate functions).

To define the active polarity of a signal, a suffix will be used. Signals ending with an "N" should be interpreted as being active, or asserted, when at a logic zero (low) level. All other signals (including clocks, buses, and select lines) will be interpreted as being active, or asserted, when at a logic one (high) level.

Signal	Type	Name/Description
Memory and Peripheral Bus		
BDIRN	0	External Buffer Direction. Memory and peripheral bus external data bus buffer direction control. If the RC32336 memory and peripheral bus is connected to the A side of a transceiver such as an IDT74FCT245, then this pin may be directly connected to the direction control (e.g., BDIR) pin of the transceiver.
BOEN[1:0]	0	External Buffer Enable. These signals provide output enable control for external buffers on the memory and peripheral data bus.
BWEN[3:0]	0	Byte Write Enables. These signals are memory and peripheral bus byte write enable signals. BWEN[0] corresponds to byte lane MDATA[7:0] BWEN[1] corresponds to byte lane MDATA[15:8] BWEN[2] corresponds to byte lane MDATA[23:16] BWEN[3] corresponds to byte lane MDATA[31:24] During PC Card accesses the BWEN[0] acts as the PC Card memory output enable (OE#) signal and BWEN[1] acts as the PC Card memory write enable (WE#) signal.
CSN[5:0]	0	Chip Selects. These signals are used to select an external device on the memory and peripheral bus.
MADDR[21:0]	0	Address Bus. 22-bit memory and peripheral bus address bus. MADDR[25:22] are available as GPIO[5:2] alternate functions.
MDATA[31:0]	I/O	Data Bus. 32-bit memory and peripheral data bus. During a cold reset, bits 0 through 16 of this data bus function as inputs that are used to load the boot configuration vector.
OEN	0	Output Enable. This signal is asserted when data should be driven by an external device on the memory and peripheral bus.
RWN	0	Read Write. This signal indicates whether the transaction on the memory and peripheral bus is a read transaction or a write transaction. A high level indicates a read from an external device. A low level indicates a write to an external device.
WAITACKN	1	Wait or Transfer Acknowledge. When configured as wait, this signal is asserted during a memory and peripheral bus transaction to extend the bus cycle. When configured as a transfer acknowledge, this signal is asserted during a transaction to signal the completion of the transaction.
RASN	0	SDRAM Row Address Strobe. Row address strobe asserted during memory and peripheral bus SDRAM transactions.
CASN	0	SDRAM Column Address Strobe. Column address strobe asserted during memory and peripheral bus SDRAM transactions.
SDCSN[1:0]	0	SDRAM Chip Selects. These signals are used to select SDRAM device(s) on the memory and peripheral bus.
SDWEN	0	SDRAM Write Enable. This signal is asserted during memory and peripheral bus SDRAM write transactions.
SDCLKOUT	0	SDRAM Clock Output. This clock is used for all SDRAM memory and peripheral bus operations.

Table 1 Pin Description (Part 1 of 6)

Signal	Type	Name/Description
SDCLKINP	I	SDRAM Clock Input. This clock input is typically a delayed version of SDCLKOUT. Data from the SDRAMs is sampled using this clock.
General Purpose I/O		
GPIO[0]	I/O	General Purpose I/O. This pin can be configured as a general purpose I/O pin. Alternate function pin name: U0SOUT Alternate function: UART channel 0 serial output.
GPIO[1]	I/O	General Purpose I/O. This pin can be configured as a general purpose I/O pin. Alternate function pin name: U0SINP Alternate function: UART channel 0 serial input.
GPIO[2]	I/O	General Purpose I/O. This pin can be configured as a general purpose I/O pin. Alternate function pin name: MADDR[22] Alternate function: Memory and Peripheral bus address bit 22 (output).
GPIO[3]	I/O	General Purpose I/O. This pin can be configured as a general purpose I/O pin. Alternate function pin name: MADDR[23] Alternate function: Memory and Peripheral bus address bit 23 (output).
GPIO[4]	I/O	General Purpose I/O. This pin can be configured as a general purpose I/O pin. Alternate function pin name: MADDR[24] Alternate function: Memory and Peripheral bus address bit 24 (output).
GPIO[5]	I/O	General Purpose I/O. This pin can be configured as a general purpose I/O pin. Alternate function pin name: MADDR[25] Alternate function: Memory and Peripheral bus address bit 25 (output).
GPIO[6]	I/O	General Purpose I/O. This pin can be configured as a general purpose I/O pin. The value of this pin may be used as a Counter Timer Clock input.
GPIO[7]	I/O	General Purpose I/O. This pin can be configured as a general purpose I/O pin. Alternate function pin name: SDCKENP Alternate function: SDRAM clock enable output The value of this pin may be used as a Counter Timer Clock input.
GPIO[8]	I/O	General Purpose I/O. This pin can be configured as a general purpose I/O pin. Alternate function pin name: CEN1 Alternate function: PCMCIA chip enable 1 (CE1#) (output).
GPIO[9]	I/O	General Purpose I/O. This pin can be configured as a general purpose I/O pin. Alternate function pin name: CEN2 Alternate function: PCMCIA chip enable 2 (CE2#) (output).
GPIO[10]	I/O	General Purpose I/O. This pin can be configured as a general purpose I/O pin. Alternate function pin name: REGN Alternate function: PCMCIA Attribute Memory Select (REG#) (output).
GPIO[11]	I/O	General Purpose I/O. This pin can be configured as a general purpose I/O pin. Alternate function pin name: IORDN Alternate function: PCMCIA IO Read (IORD#) (output).
GPIO[12]	I/O	General Purpose I/O. This pin can be configured as a general purpose I/O pin. Alternate function pin name: IOWRN Alternate function: PCMCIA IO Write (IOWR#) (output).
GPIO[13]	I/O	General Purpose I/O. This pin can be configured as a general purpose I/O pin. Alternate function pin name: PCIREQN[2] Alternate function: PCI bus request 2 (output).

Table 1 Pin Description (Part 2 of 6)

Signal	Type	Name/Description
GPIO[14]	I/O	General Purpose I/O. This pin can be configured as a general purpose I/O pin. Alternate function pin name: PCIGNTN[2] Alternate function: PCI bus grant 2 (output).
GPIO[15]	I/O	General Purpose I/O. This pin can be configured as a general purpose I/O pin. Alternate function pin name: PCIMUINTN Alternate function: PCI Messaging unit interrupt output.
Serial Interface		
SCK	I/O	Serial Clock. This signal is used as the serial SPI clock output. This pin may be used as a bit input/output port.
SDI	I/O	Serial Data Input. This signal is used to shift in serial SPI data. This pin may be used as a bit input/output port.
SDO	I/O	Serial Data Output. This signal is used to shift out serial SPI data. This pin may be used as a bit input/output port.
PCI Bus		
PCIAD[31:0]	I/O	PCI Multiplexed Address/Data Bus. Address is driven by a bus master during initial PCIFRAMEN assertion. Data is then driven by the bus master during writes or by the bus target during reads.
PCICBEN[3:0]	I/O	PCI Multiplexed Command/Byte Enable Bus. PCI command is driven by the bus master during the initial PCIFRAMEN assertion. Byte enables are driven by the bus master during subsequent data phase(s).
PCICLK	I	PCI Clock. Clock used for all PCI bus transactions.
PCIDEVSELN	I/O	PCI Device Select. This signal is driven by a bus target to indicate that the target has decoded the address as one of its own address spaces.
PCIFRAMEN	I/O	PCI Frame. Driven by a bus master. Assertion indicates the beginning of a bus transaction. Negation indicates the last data.
PCIGNTN[1:0]	I/O	PCI Bus Grant. In PCI host mode with internal arbiter: The assertion of these signals indicates to the agent that the internal RC32336 arbiter has granted the agent access to the PCI bus. In PCI host mode with external arbiter: PCIGNTN[0]: asserted by an external arbiter to indicate to the RC32336 that access to the PCI bus has been granted. PCIGNTN[1]: unused and driven high. In PCI satellite mode: PCIGNTN[0]: this signal is asserted by an external arbiter to indicate to the RC32336 that access to the PCI bus has been granted. PCIGNTN[1]: this signal takes on the alternate function of PCIEECS and is used as a PCI Serial EEPROM chip select.
PCIIRDYN	I/O	PCI Initiator Ready. Driven by the bus master to indicate that the current data can complete.
PCILOCKN	I/O	PCI Lock. This signal is asserted by an external bus master to indicate that an exclusive operation is occurring.
PCIPAR	I/O	PCI Parity. Even parity of the PCIAD[31:0] bus. Driven by the bus master during address and write data phases. Driven by the bus target during the read data phases.
PCIPERRN	I/O	PCI Parity Error. This signal is asserted by the receiving bus agent 2 clocks after the data is received if a parity error is detected.

Table 1 Pin Description (Part 3 of 6)

Signal	Type	Name/Description
PCIREQN[1:0]	I/O	<p>PCI Bus Request. In PCI host mode with internal arbiter: These signals are inputs whose assertion indicates to the internal RC32336 arbiter that an agent desires ownership of the PCI bus. In PCI host mode with external arbiter: PCIREQN[0]: asserted by the RC32336 to request ownership of the PCI bus. PCIREQN[1]: unused and driven high. In PCI satellite mode: PCIREQN[0]: this signal is asserted by the RC32336 to request ownership of the PCI bus. PCIREQN[1]: function changes to PCIIDSEL and is used as a chip select during configuration read and write transactions.</p>
PCIRSTN	I/O	PCI Reset. In host mode, this signal is asserted by the RC32336 to generate a PCI reset. In satellite mode, assertion of this signal initiates a warm reset.
PCISERRN	I/O	PCI System Error. This signal is driven by an agent to indicate an address parity error, data parity error during a special cycle command, or any other system error. Requires an external pull-up.
PCISTOPN	I/O	PCI Stop. Driven by the bus target to terminate the current bus transaction. For example, to indicate a retry.
PCITRDYN	I/O	PCI Target Ready. Driven by the bus target to indicate that the current data can complete.
Ethernet Interface		
MII0CL	I	Ethernet 0 MII Collision Detected. This signal is asserted by the ethernet PHY when a collision is detected.
MII0CRS	I	Ethernet 0 MII Carrier Sense. This signal is asserted by the ethernet PHY when either the transmit or receive medium is not idle.
MII0RXCLK	I	Ethernet 0 MII Receive Clock. This clock is a continuous clock that provides a timing reference for the reception of data.
MII0RXD[3:0]	I	Ethernet 0 MII Receive Data. This nibble wide data bus contains the data received by the ethernet PHY.
MII0RXDV	I	Ethernet 0 MII Receive Data Valid. The assertion of this signal indicates that valid receive data is in the MII receive data bus.
MII0RXER	I	Ethernet 0 MII Receive Error. The assertion of this signal indicates that an error was detected somewhere in the ethernet frame currently being sent in the MII receive data bus.
MII0TXCLK	I	Ethernet 0 MII Transmit Clock. This clock is a continuous clock that provides a timing reference for the transfer of transmit data.
MII0TXD[3:0]	O	Ethernet 0 MII Transmit Data. This nibble wide data bus contains the data to be transmitted.
MII0TXENP	O	Ethernet 0 MII Transmit Enable. The assertion of this signal indicates that data is present on the MII for transmission.
MII0TXER	O	Ethernet 0 MII Transmit Coding Error. When this signal is asserted together with MII0TXENP, the ethernet PHY will transmit symbols which are not valid data or delimiters.
MII1CL	I	Ethernet 1 MII Collision Detected. This signal is asserted by the ethernet PHY when a collision is detected.
MII1CRS	I	Ethernet 1 MII Carrier Sense. This signal is asserted by the ethernet PHY when either the transmit or receive medium is not idle.
MII1RXCLK	I	Ethernet 1 MII Receive Clock. This clock is a continuous clock that provides a timing reference for the reception of data.

Table 1 Pin Description (Part 4 of 6)

Signal	Type	Name/Description
MII1RXD[3:0]	I	Ethernet 1 MII Receive Data. This nibble wide data bus contains the data received by the ethernet PHY.
MII1RXDV	I	Ethernet 1 MII Receive Data Valid. The assertion of this signal indicates that valid receive data is in the MII receive data bus.
MII1RXER	I	Ethernet 1 MII Receive Error. The assertion of this signal indicates that an error was detected somewhere in the ethernet frame currently being sent in the MII receive data bus.
MII1TXCLK	I	Ethernet 1 MII Transmit Clock. This clock is a continuous clock that provides a timing reference for the transfer of transmit data.
MII1TXD[3:0]	O	Ethernet 1 MII Transmit Data. This nibble wide data bus contains the data to be transmitted.
MII1TXENP	O	Ethernet 1 MII Transmit Enable. The assertion of this signal indicates that data is present on the MII for transmission.
MII1TXER	O	Ethernet 1 MII Transmit Coding Error. When this signal is asserted together with MII1TXENP, the ethernet PHY will transmit symbols which are not valid data or delimiters.
MIIMDC	O	MII Management Data Clock. This signal is used as a timing reference for transmission of data on the management interface.
MIIMDIO	I/O	MII Management Data. This bidirectional signal is used to transfer data between the station management entity and the ethernet PHY.
EJTAG / JTAG		
JTAG_TMS	I	JTAG Mode. The value on this signal controls the test mode select of the boundary scan logic or JTAG Controller. When using the EJTAG debug interface, this pin should be left disconnected (since there is an internal pull-up) or driven high.
EJTAG_TMS	I	EJTAG Mode. The value on this signal controls the test mode select of the EJTAG Controller. When using the JTAG boundary scan, this pin should be left disconnected (since there is an internal pull-up) or driven high.
JTAG_TRST_N	I	JTAG Reset. This active low signal asynchronously resets the boundary scan logic, JTAG TAP Controller, and the EJTAG Debug TAP Controller. An external pull-up on the board is recommended to meet the JTAG specification in cases where the tester can access this signal. However, for systems running in functional mode, one of the following should occur: 1) actively drive this signal low with control logic 2) statically drive this signal low with an external pull-down on the board 3) clock JTAG_TCK while holding EJTAG_TMS and/or JTAG_TMS high.
JTAG_TCK	I	JTAG Clock. This is an input test clock used to clock the shifting of data into or out of the boundary scan logic, JTAG Controller, or the EJTAG Controller. JTAG_TCK is independent of the system and the processor clock with a nominal 50% duty cycle.
JTAG_TDO	O	JTAG Data Output. This is the serial data shifted out from the boundary scan logic, JTAG Controller, or the EJTAG Controller. When no data is being shifted out, this signal is tri-stated.
JTAG_TDI	I	JTAG Data Input. This is the serial data input to the boundary scan logic, JTAG Controller, or the EJTAG Controller.

Table 1 Pin Description (Part 5 of 6)

Signal	Type	Name/Description
Miscellaneous		
CLK	I	Master Clock. This is the master clock input. The processor frequency is a multiple of this clock frequency. This clock is used as the system clock for all memory and peripheral bus operations except those associated with SDRAMs.
COLDRSTN	I	Cold Reset. The assertion of this signal initiates a cold reset. This causes the processor state to be initialized, boot configuration to be loaded, and the internal PLL to lock onto the master clock (CLK).
RSTN	I/O	Reset. The assertion of this bidirectional signal initiates a warm reset. This signal is asserted by the RC32336 during a warm reset. It can also be asserted by an external device to force the RC32336 to take a warm reset exception.

Table 1 Pin Description (Part 6 of 6)

Pin Characteristics

Pin Name	Type	Buffer	I/O Type	Internal Resistor	External Resistor ¹
Memory and Peripheral Bus					
BDIRN	0	LVTTTL	High Drive		
BOEN[1:0]	0	LVTTTL	High Drive		
BWEN[3:0]	0	LVTTTL	High Drive		
CSN[5:0]	0	LVTTTL	High Drive		
MADDR[21:0]	0	LVTTTL	High Drive		
MDATA[31:0]	I/O	LVTTTL	High Drive		
OEN	0	LVTTTL	High Drive		
RWN	0	LVTTTL	High Drive		
WAITACKN	I	LVTTTL	STI ²	pull-up	
RASN	0	LVTTTL	High Drive		
CASN	0	LVTTTL	High Drive		
SDCSN[1:0]	0	LVTTTL	High Drive		
SDWEN	0	LVTTTL	High Drive		
SDCLKOUT	0	LVTTTL	High Drive		
SDCLKINP	I	LVTTTL	STI	pull-up	
General Purpose I/O					
GPIO[15:13]	I/O	PCI	PCI		
GPIO[12:0]	I/O	LVTTTL	Low Drive	pull-up	
Serial Interface					
SCK	I/O	LVTTTL	Low Drive	pull-up	pull-up on board
SDI	I/O	LVTTTL	Low Drive	pull-up	pull-up on board
SDO	I/O	LVTTTL	Low Drive	pull-up	pull-up on board
PCI Bus Interface					
PCIAD[31:0]	I/O	PCI	PCI		
PCICBEN[3:0]	I/O	PCI	PCI		
PCICLK	I	PCI	PCI		
PCIDEVSELN	I/O	PCI	PCI		pull-up on board

Table 2 Pin Characteristics (Part 1 of 2)

Pin Name	Type	Buffer	I/O Type	Internal Resistor	External Resistor ¹
PCIFRAMEN	I/O	PCI	PCI		pull-up on board
PCIGNTN[1:0]	I/O	PCI	PCI		pull-up on board
PCIIRDYN	I/O	PCI	PCI		pull-up on board
PCILOCKN	I/O	PCI	PCI		
PCIPAR	I/O	PCI	PCI		
PCIPERRN	I/O	PCI	PCI		
PCIREQN[1:0]	I/O	PCI	PCI		pull-up on board
PCIRSTN	I/O	PCI	PCI		pull-down on board
PCISERRN	I/O	PCI	Open Collector; PCI		pull-up on board
PCISTOPN	I/O	PCI	PCI		pull-up on board
PCITRDYN	I/O	PCI	PCI		pull-up on board
Ethernet Interfaces					
MII0CL	I	LVTTTL	STI	pull-up	
MII0CRS	I	LVTTTL	STI	pull-up	
MII0RXCLK	I	LVTTTL	STI	pull-up	
MII0RXD[3:0]	I	LVTTTL	STI	pull-up	
MII0RXDV	I	LVTTTL	STI	pull-up	
MII0RXER	I	LVTTTL	STI	pull-up	
MII0TXCLK	I	LVTTTL	STI	pull-up	
MII0TXD[3:0]	O	LVTTTL	Low Drive		
MII0TXENP	O	LVTTTL	Low Drive		
MII0TXER	O	LVTTTL	Low Drive		
MII1CL	I	LVTTTL	STI	pull-up	
MII1CRS	I	LVTTTL	STI	pull-up	
MII1RXCLK	I	LVTTTL	STI	pull-up	
MII1RXD[3:0]	I	LVTTTL	STI	pull-up	
MII1RXDV	I	LVTTTL	STI	pull-up	
MII1RXER	I	LVTTTL	STI	pull-up	
MII1TXCLK	I	LVTTTL	STI	pull-up	
MII1TXD[3:0]	O	LVTTTL	Low Drive		
MII1TXENP	O	LVTTTL	Low Drive		
MII1TXER	O	LVTTTL	Low Drive		
MIIMDC	O	LVTTTL	Low Drive		
MIIMDIO	I/O	LVTTTL	Low Drive	pull-up	
EJTAG / JTAG					
JTAG_TMS	I	LVTTTL	STI	pull-up	See Chapters 22 and 23 of the RC32336 User Reference Manual
EJTAG_TMS	I	LVTTTL	STI	pull-up	
JTAG_TRST_N	I	LVTTTL	STI	pull-up	
JTAG_TCK	I	LVTTTL	STI	pull-up	
JTAG_TDO	O	LVTTTL	Low Drive		
JTAG_TDI	I	LVTTTL	STI	pull-up	
Miscellaneous					
CLK	I	LVTTTL	STI		
COLDRSTN	I	LVTTTL	STI		
RSTN	I/O	LVTTTL	Low Drive / STI	pull-up	pull-up on board

Table 2 Pin Characteristics (Part 2 of 2)

¹ External pull-up required in most system applications. Some applications may require additional pull-ups not identified in this table.

² Schmidt Trigger Input (STI).

Boot Configuration Vector

The boot configuration vector is read into the RC32336 during cold reset. The vector defines parameters in the RC32336 that are essential to operation when cold reset is complete.

The encoding of boot configuration vector is described in Table 3, and the vector input is illustrated in Figure 4.

Signal	Name/Description
MDATA[2:0]	CPU Clock Multiplier. This field specifies the value by which the PLL multiplies the master clock input (CLK) to obtain the processor clock frequency (PCLK). 0x0 - Multiply by 2 0x1 - 0x7 — Reserved
MDATA[3]	Endian. This bit specifies the endianness. 0x0 - little endian 0x1 - big endian
MDATA[4]	Reserved. This pin may be driven high or low during boot configuration and its state is recorded in the Boot Configuration Vector (BCV) field of the BCV register. This reserved bit may be used to pass boot configuration parameters to software.
MDATA[6:5]	Boot Device Width. This field specifies the width of the boot device (i.e., Device 0). 0x0 - 8-bit boot device width 0x1 - 16-bit boot device width 0x2 - 32-bit boot device width 0x3 - reserved
MDATA[7]	Reset Mode. This bit specifies the length of time the RSTN signal is driven. 0x0 - Normal reset: RSTN driven for minimum of 4096 clock cycles 0x1 - reserved
MDATA[8]	Disable Watchdog Timer. When this bit is set, the watchdog timer is disabled following a cold reset. 0x0 - Watchdog timer is enabled 0x1 - Watchdog timer is disabled
MDATA[11:9]	PCI Mode. This bit controls the operating mode of the PCI bus interface. The initial value of the EN bit in the PCIC register is determined by the PCI mode. 0x0 - Disabled (EN initial value is zero) 0x1 - PCI satellite mode with PCI target not ready (EN initial value is one) 0x2 - PCI satellite mode with suspended CPU execution (EN initial value is one) 0x3 - PCI host mode with external arbiter (EN initial value is zero) 0x4 - PCI host mode with internal arbiter using fixed priority arbitration algorithm (EN initial value is zero) 0x5 - PCI host mode with internal arbiter using round robin arbitration algorithm (EN initial value is zero) 0x6 - reserved 0x7 - reserved
MDATA[15:12]	Reserved. These pins may be driven high or low during boot configuration and their state is recorded in the Boot Configuration Vector (BCV) field of the BCV register. These reserved bits may be used to pass boot configuration parameters to software.

Table 3 Boot Configuration Vector Encoding

Logic Diagram

The following Logic Diagram shows the primary pin functions of the RC32336.

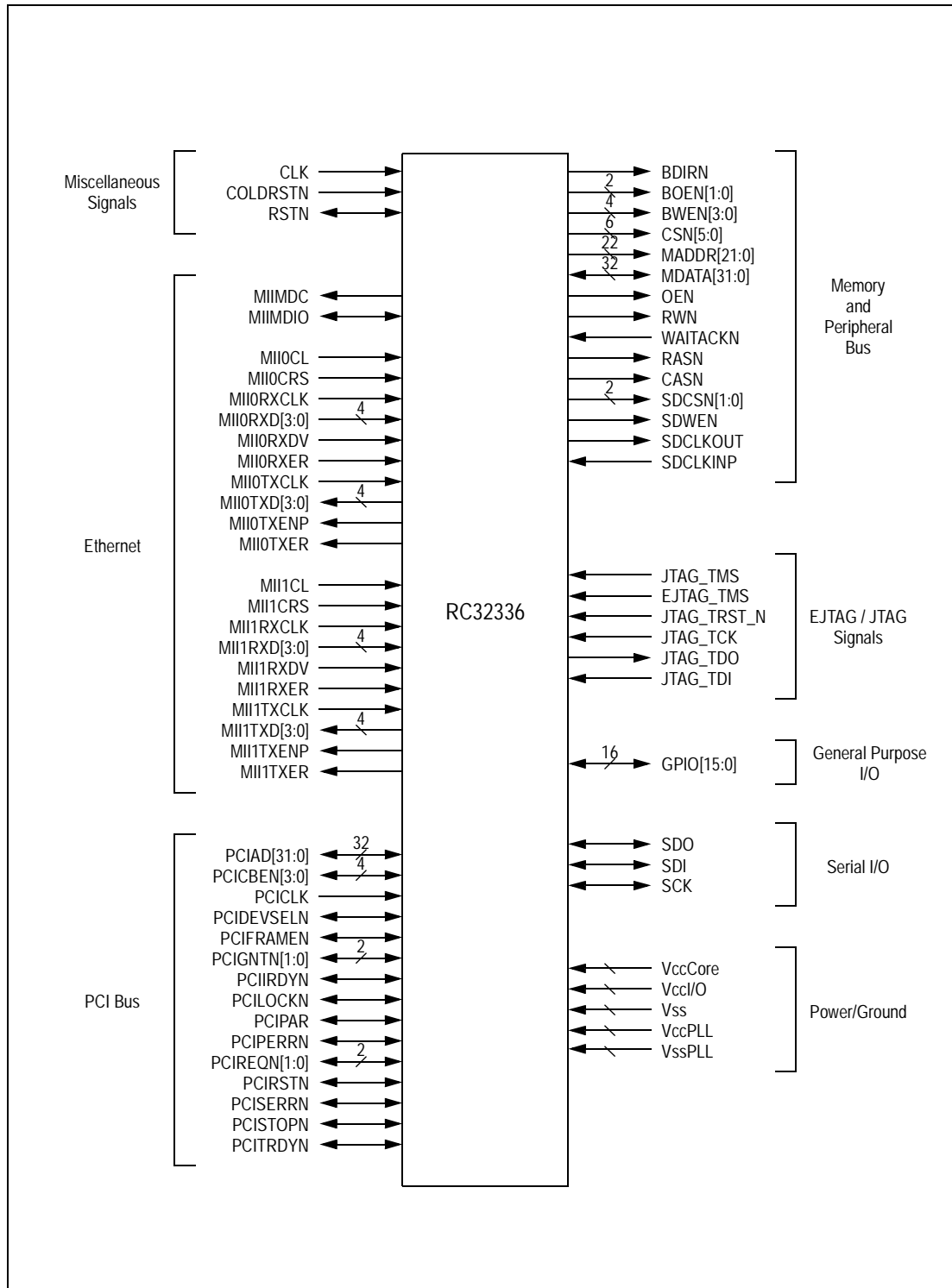

Figure 1 RC32336 Logic Diagram

AC Timing Definitions

Below are examples of the AC timing characteristics used throughout this document.

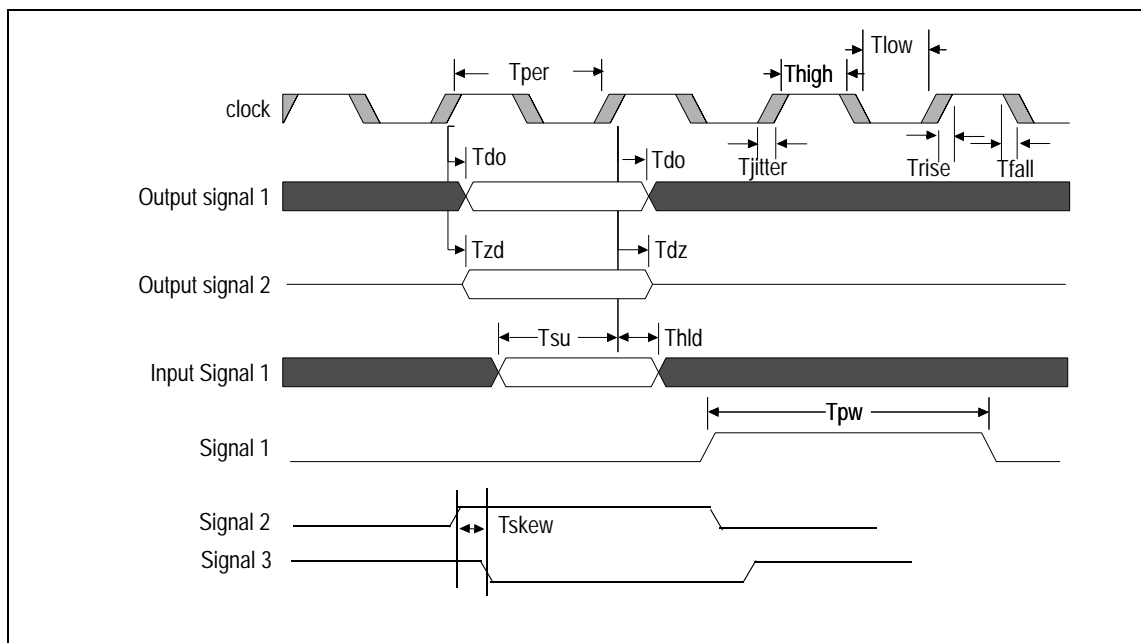

Figure 2 AC Timing Definitions Waveform

Symbol	Definition
Tper	Clock period.
Tlow	Clock low. Amount of time the clock is low in one clock period.
Thigh	Clock high. Amount of time the clock is high in one clock period.
Trise	Rise time. Low to high transition time.
Tfall	Fall time. High to low transition time.
Tjitter	Jitter. Amount of time the reference clock (or signal) edge can vary on either the rising or falling edges.
Tdo	Data out. Amount of time after the reference clock edge that the output will become valid. The minimum time represents the data output hold. The maximum time represents the earliest time the designer can use the data.
Tzd	Z state to data valid. Amount of time after the reference clock edge that the tri-stated output takes to become valid.
Tdz	Data valid to Z state. Amount of time after the reference clock edge that the valid output takes to become tri-stated.
Tsu	Input set-up. Amount of time before the reference clock edge that the input must be valid.
Thld	Input hold. Amount of time after the reference clock edge that the input must remain valid.
Tpw	Pulse width. Amount of time the input or output is active for asynchronous signals.
Tslew	Slew rate. The rise or fall rate for a signal to go from a high to low, or low to high.
X(clock)	Timing value. This notation represents a value of 'X' multiplied by the clock time period of the specified clock. Using 5(CLK) as an example: X = 5 and the oscillator clock (CLK) = 25MHz, then the timing value is 200.
Tskew	Skew. The amount of time two signal edges deviate from one another.

Table 4 AC Timing Definitions

Clock Parameters

The values given below are based on systems running at recommended supply voltages and operating temperatures, as shown in Tables 14 and 15.

Parameter	Symbol	Reference Edge	150MHz		Units	Timing Diagram Reference
			Min	Max		
PCLK ¹	Frequency	none	100	150	MHz	See Figure 3
CLK ^{2,3}	Frequency	none	50	75	MHz	
	Tper_5a		13.3	20	ns	
	Thigh_5a, Tlow_5a		40	60	% of Tper_5a	
	Trise_5a, Tfall_5a		—	3.0	ns	
Tjitter_5a	—	± 250	ps			

Table 5 RC32336 Clock Parameters

- ¹ The CPU pipeline clock (PCLK) speed is selected during cold reset by the boot configuration vector (see Table 3).
- ² Ethernet clock (MIIxRXCLK and MIIxTXCLK) frequency must be less than or equal to 1/2 CLK frequency.
- ³ PCI clock (PCICLK) frequency must be less than or equal to two times CLK.

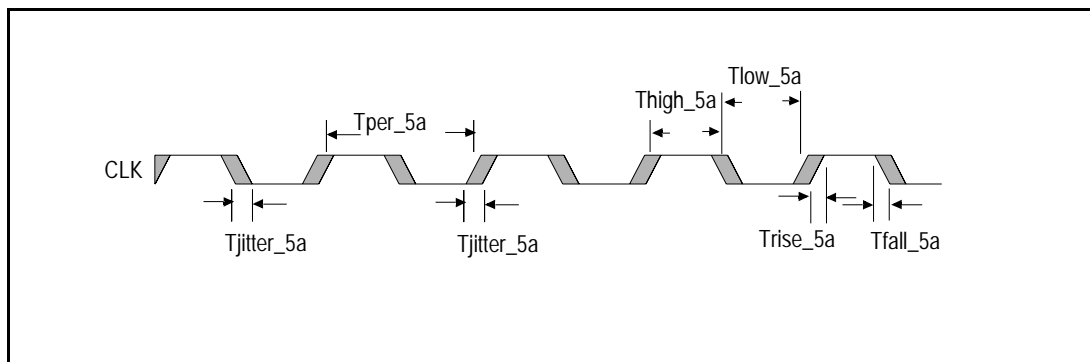

Figure 3 Clock Parameters Waveform

AC Timing Characteristics

The values given below are based on systems running at recommended operating supply voltages and temperatures as shown in Tables 14 and 15.

Signal	Symbol	Reference Edge	150MHz		Unit	Conditions	Timing Diagram Reference
			Min	Max			
Reset and System							
COLDRSTN	Tpw_6a ¹	none	110	—	ms	Cold reset	See Figures 4 and 5
	Trise_6a		—	5.0	ns	Cold reset	
RSTN ² (output)	Tdo_6b	CLK rising	2.0	9.0	ns	Cold reset	
RSTN ² (input)	Tpw_6c ¹	none	2(CLK)	—	ns	Cold reset	
MDATA[15:0] Boot Configuration Vector	Thld_6d	COLDRSTN rising	3.0	—	ns	Cold reset	
	Tdz_6d ¹	COLDRSTN falling	—	2(CLK)	ns	Cold reset	
	Tdz_6d ¹	RSTN falling	—	2(CLK)	ns	Warm reset	
	Tzd_6d ¹	RSTN rising	3.0	—	ns	Warm reset	

Table 6 Reset and System AC Timing Characteristics

¹. The values for this symbol were determined by calculation, not by testing.

². RSTN is a bidirectional signal. It is treated as an asynchronous input.

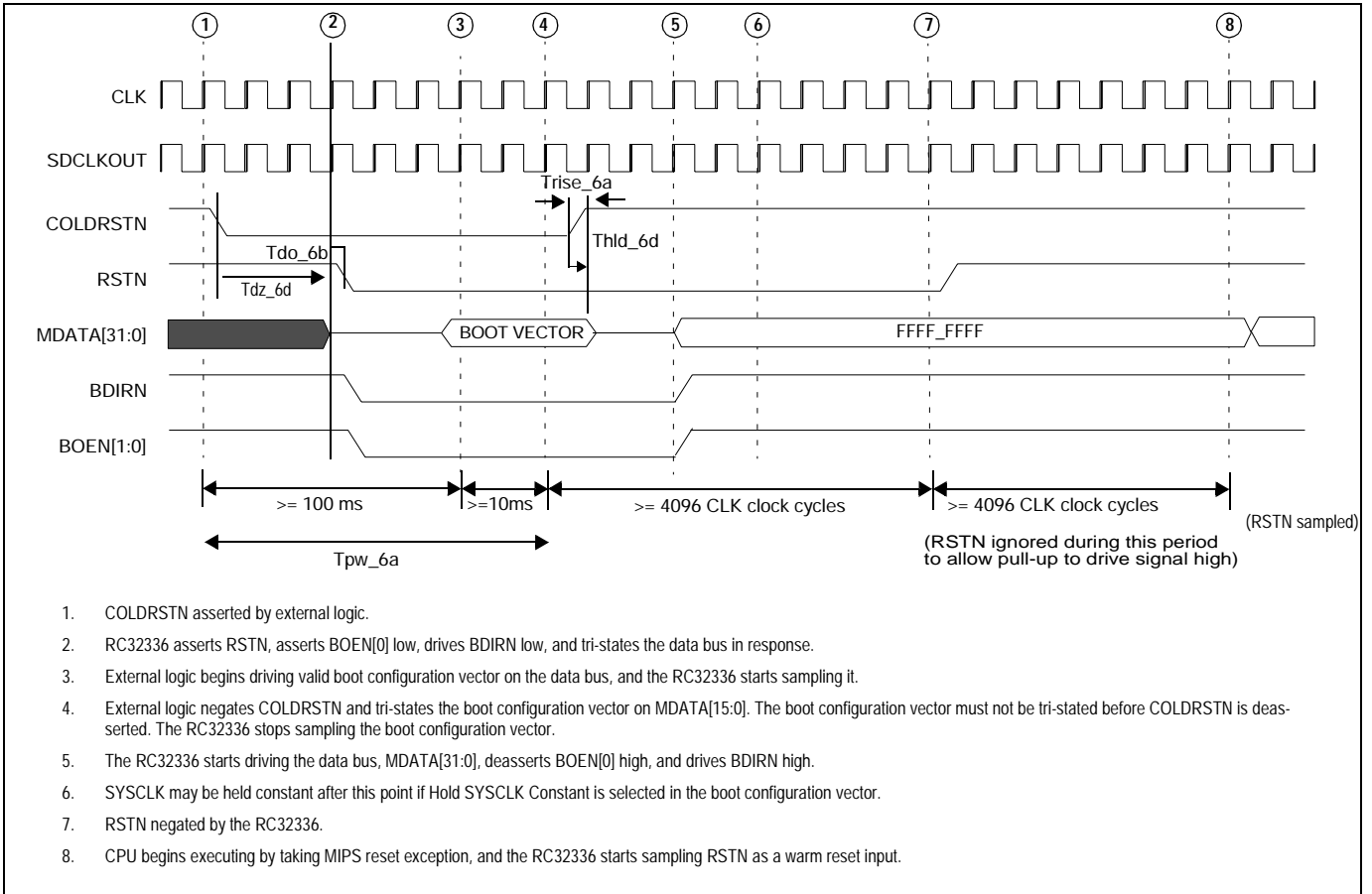

Figure 4 Cold Reset AC Timing Waveform

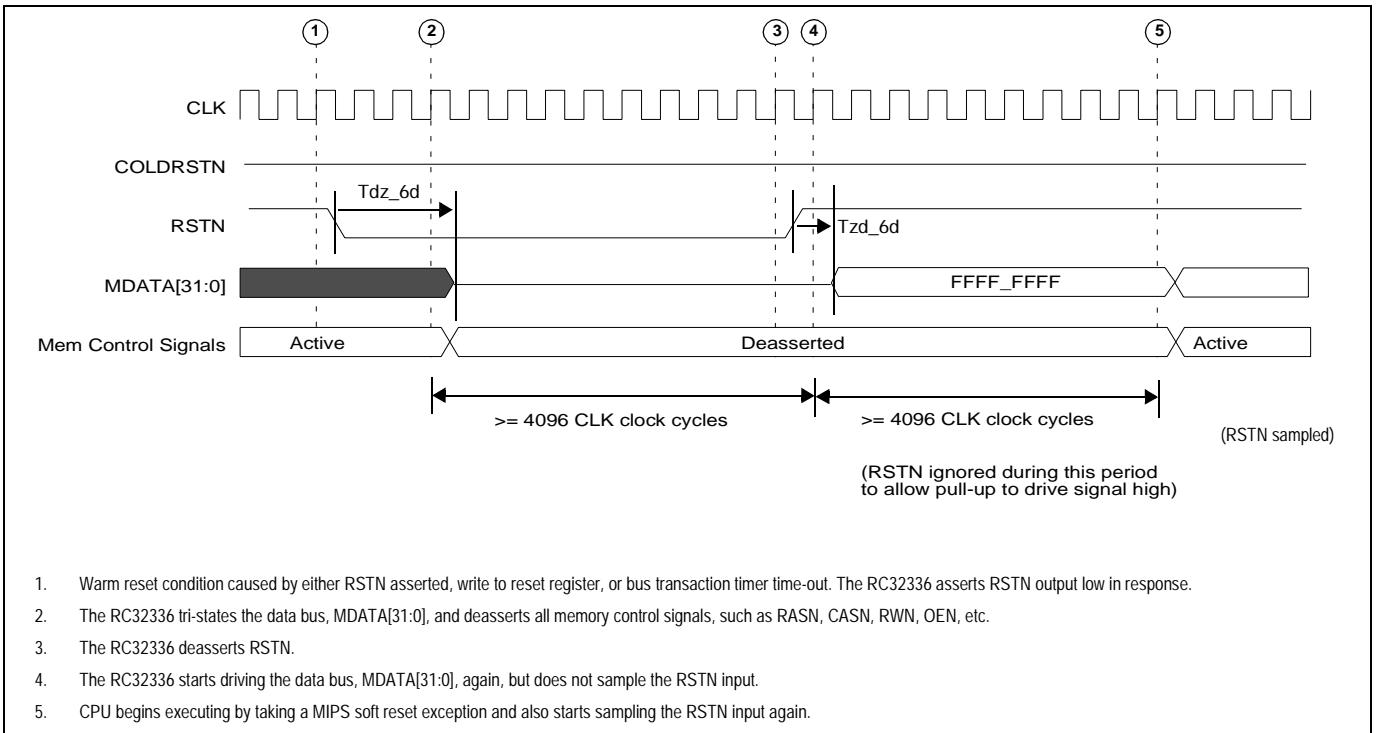

Figure 5 Warm Reset AC Timing Waveform

Signal	Symbol	Reference Edge	150MHz		Unit	Conditions	Timing Diagram Reference
			Min	Max			
Memory and Peripheral Bus - SDRAM Access							
MDATA[31:0]	Tsu_7a	SDCLKINP rising	1.0	—	ns		See Figures 6 and 7
	Thld_7a ¹		1.7	—	ns		
	Tdo_7a	SDCLKOUT rising	1.2	6.0	ns		
	Tdz_7a ¹		1.2	7.0	ns		
	Tzd_7a ¹		1.2	8.0	ns		
MADDR[20:2]	Tdo_7b	SDCLKOUT rising	1.2	6.0	ns		
RASN	Tdo_7c	SDCLKOUT rising	1.2	6.0	ns		
CASN	Tdo_7d	SDCLKOUT rising	1.2	6.0	ns		
SDWEN	Tdo_7e	SDCLKOUT rising	1.2	6.0	ns		
SDCSN[1:0]	Tdo_7f	SDCLKOUT rising	1.2	6.0	ns		
BDIRN	Tdo_7g	SDCLKOUT rising	1.2	6.0	ns		
BOEN[1:0]	Tdo_7h	SDCLKOUT rising	1.2	6.0	ns		
BWEN[3:0]	Tdo_7i	SDCLKOUT rising	1.2	6.0	ns		
SDCLKINP	Tdelay_7k	SDCLKOUT rising	0.0	2.5	ns		See Figures 6 and 8
SDCKENP	Tdo_7l	SDCLKOUT rising	2.0	6.0	ns		

Table 7 Memory and Peripheral Bus AC Timing Characteristics

¹. The values for this symbol were determined by calculation, not by testing.

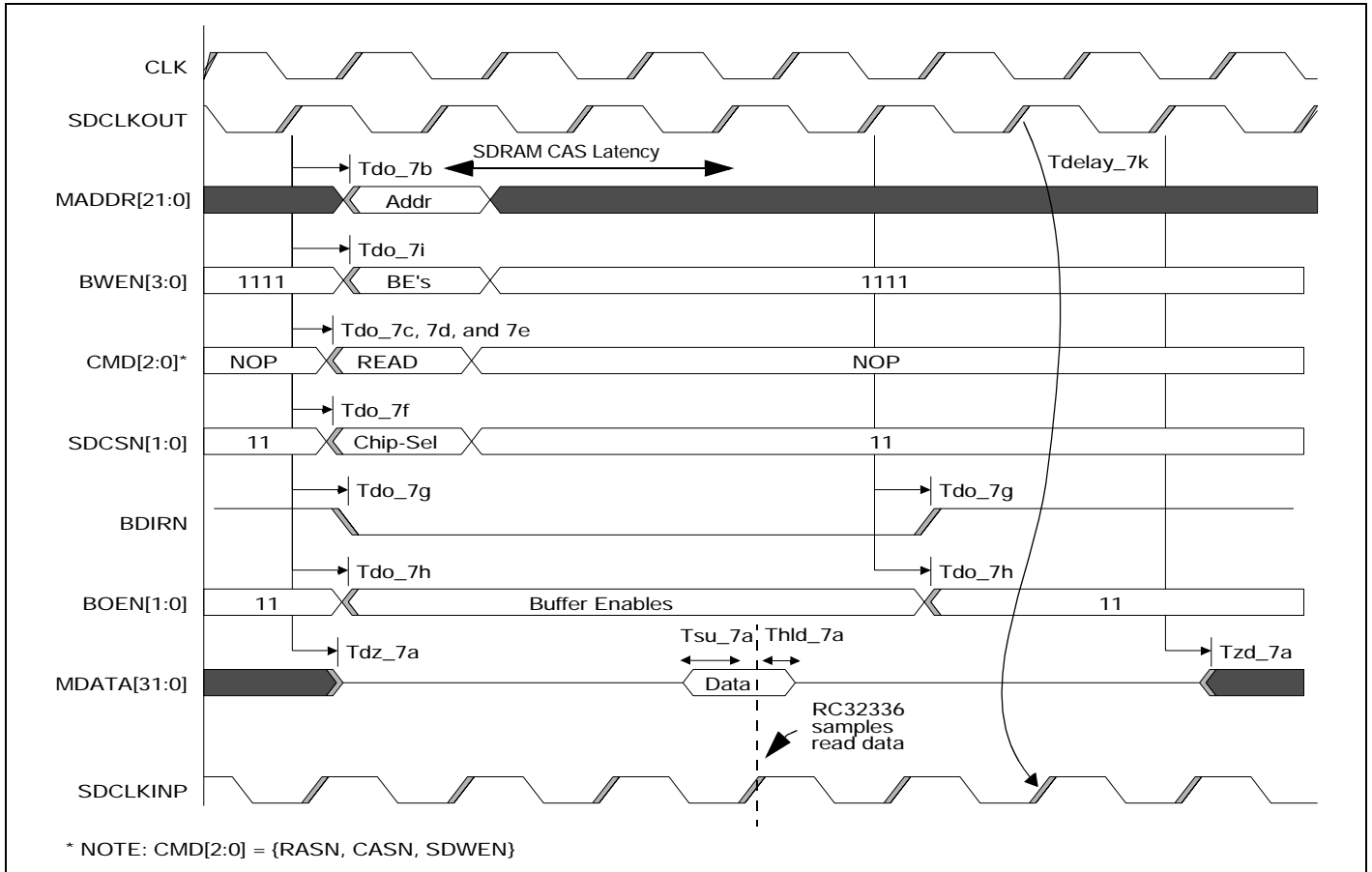

Figure 6 Memory and Peripheral Bus AC Timing Waveform - SDRAM Read Access

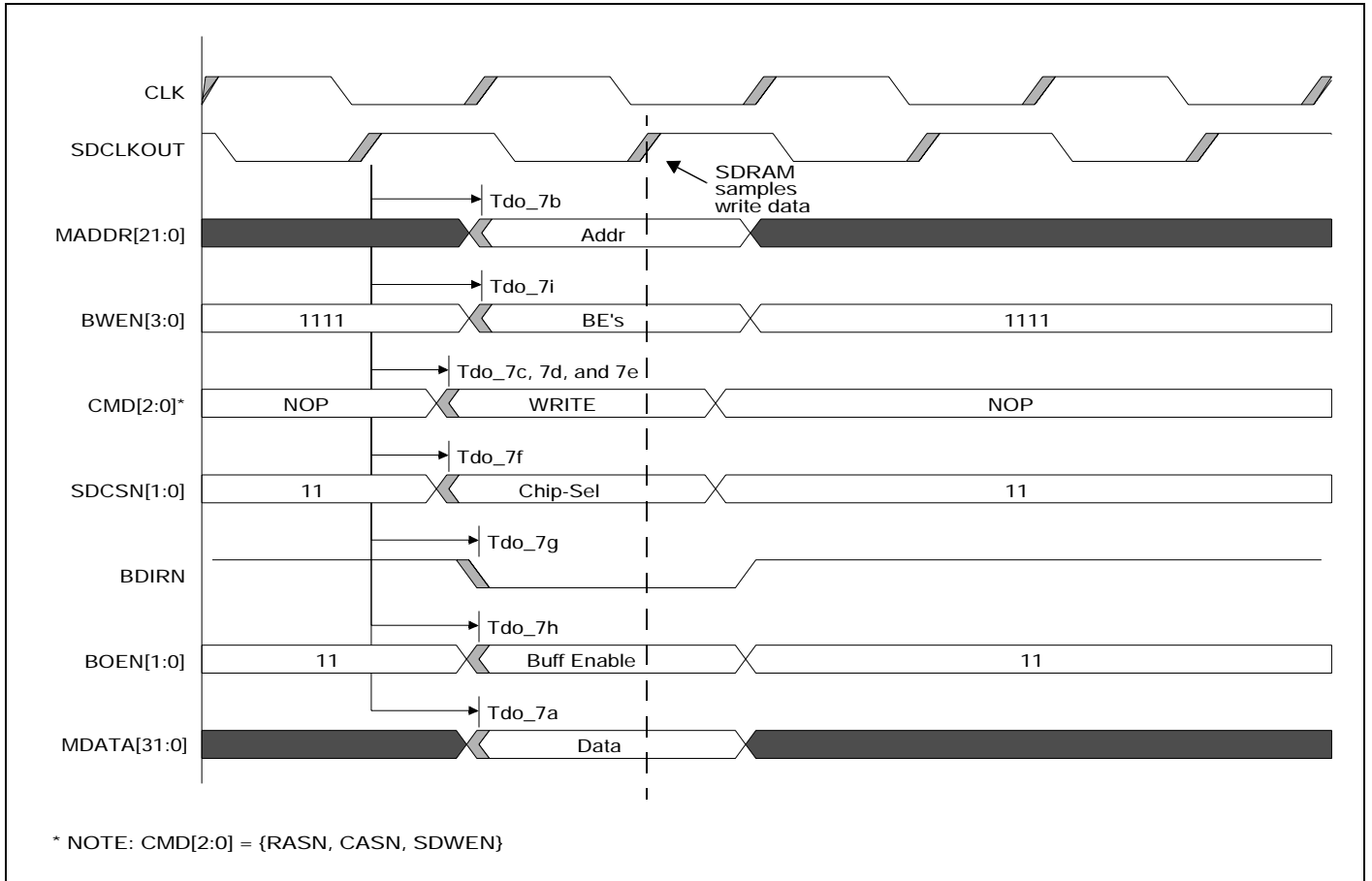

Figure 7 Memory and Peripheral Bus AC Timing Waveform - SDRAM Write Access

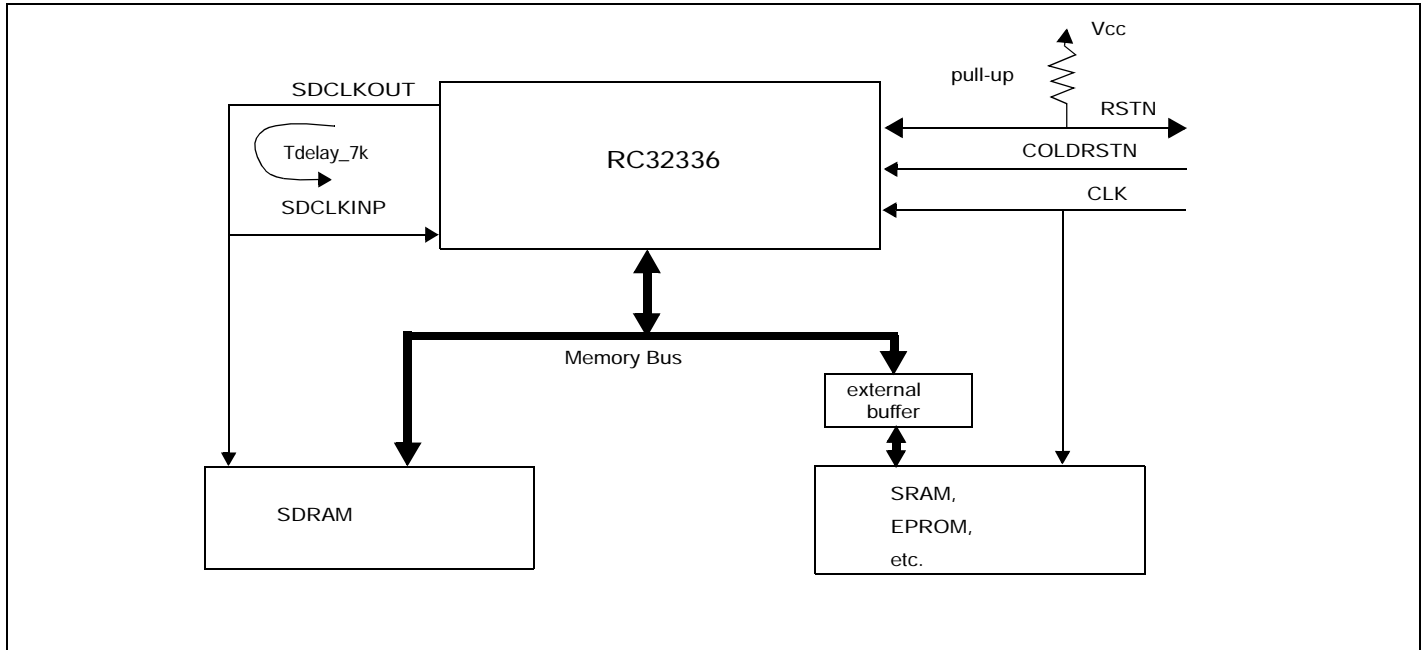

Figure 8 SDCLKOUT - SDCLKINP Relationship

Signal	Symbol	Reference Edge	150MHz		Unit	Conditions	Timing Diagram Reference
			Min	Max			
Memory and Peripheral Bus¹ — Device Access							
MDATA[31:0]	Tsu_8a	CLK rising	2.5	—	ns		See Figures 9 and 10
	Thld_8a		1.0	—	ns		
	Tdo_8a		2.0	6.5	ns		
	Tdz_8a ²		2.0	9.5	ns		
	Tzd_8a ²		2.0	10.5	ns		
MADDR[21:0]	Tdo_8b	CLK rising	2.0	6.5	ns		
MADDR[25:22]	Tdo_8c	CLK rising	3.0	7.5	ns		
CSN[5:0]	Tdo_8d	CLK rising	2.0	6.5	ns		
RWN	Tdo_8e	CLK rising	2.0	6.5	ns		
OEN	Tdo_8f	CLK rising	2.0	6.5	ns		
BWEN[1:0]	Tdo_8g	CLK rising	2.0	6.5	ns		
BDIRN	Tdo_8h	CLK rising	2.0	6.5	ns		
BOEN[1:0]	Tdo_8i	CLK rising	2.0	6.5	ns		
WAITACKN ³	Tsu_8j	CLK rising	2.0	—	ns		
	Thld_8j		0.5	—	ns		
	Tpw_8j ²	none	2(CLK)	—	ns		

Table 8 Memory and Peripheral Bus AC Timing Characteristics — Device Access (Part 1 of 2)

Signal	Symbol	Reference Edge	150MHz		Unit	Conditions	Timing Diagram Reference
			Min	Max			
CEN1 ⁴ , CEN2 ⁴	Tdo_8k	CLK rising	3.0	7.5	ns		See Figures 9 and 10 (cont.)
REGN ⁴	Tdo_8l	CLK rising	3.0	7.5	ns		
IORDN ⁴	Tdo_8m	CLK rising	3.0	7.5	ns		
IOWRN ⁴	Tdo_8n	CLK rising	3.0	7.5	ns		

Table 8 Memory and Peripheral Bus AC Timing Characteristics — Device Access (Part 2 of 2)

1. The RC32336 provides bus turnaround cycles to prevent bus contention when going from a read to write and write to read. For example, there are no cycles where an external device and the RC32336 are both driving. See Chapter 6, Device Controller, in the RC32336 User Reference Manual.
2. The values for this symbol were determined by calculation, not by testing.
3. WAITACKN must meet the setup and hold times if it is synchronous or the minimum pulse width if it is asynchronous.
4. CEN1, CEN2, REGN, IORDN, and IOWRN are alternate functions of GPIO[12:8].

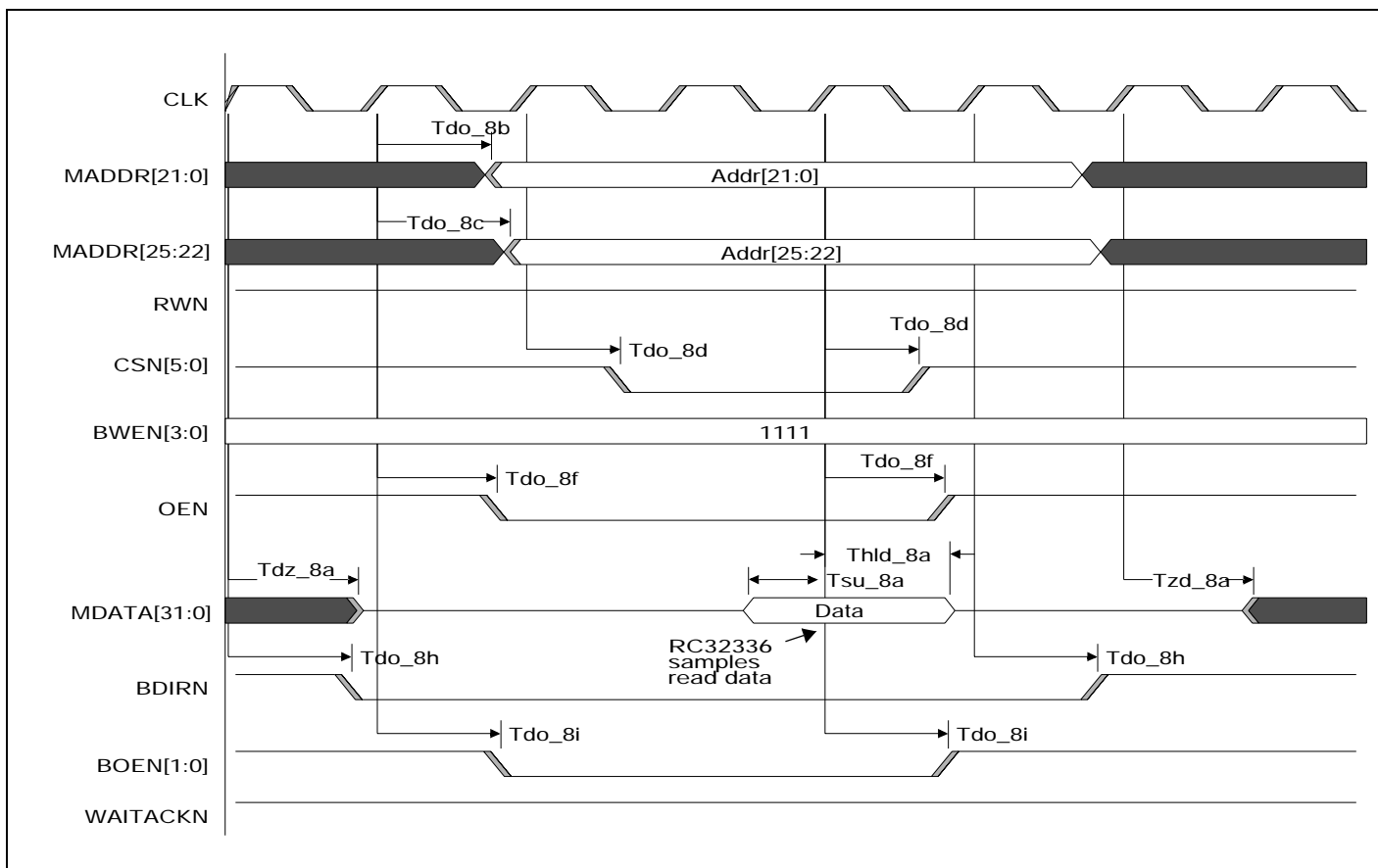

Figure 9 Memory and Peripheral Bus AC Timing Waveform - Device Read Access

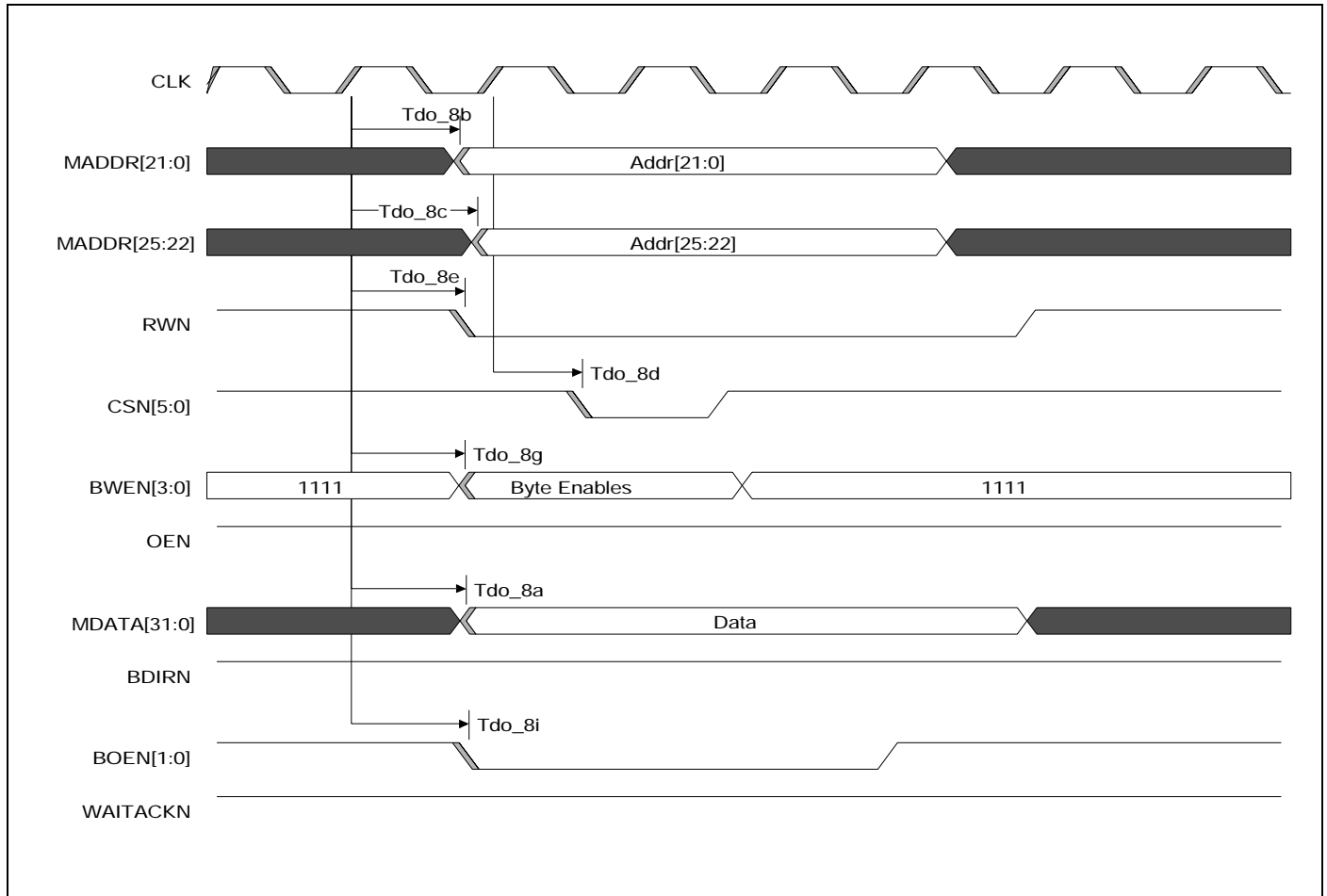

Figure 10 Memory AC and Peripheral Bus Timing Waveform - Device Write Access

Signal	Symbol	Reference Edge	150MHz		Unit	Conditions	Timing Diagram Reference
			Min	Max			
Ethernet¹							
MIIMDC	Tper_9a	None	53.3	—	ns		See Figure 11
	Thigh_9a, Tlow_9a		23.0	—	ns		
MIIMDIO	Tsu_9b	MIIMDC rising	10.0	—	ns		
	Thld_9b		1.0	—	ns		
	Tdo_9b		1(ICLK)	3(ICLK)	ns		
MIIXRXCLK, MIIXTXCLK ²	Tper_9c	None	399.96	400.4	ns	10 Mbps	
	Thigh_9c, Tlow_9c		140	260	ns		
	Trise_9c, Tfall_9c		—	3.0	ns		
MIIXRXCLK, MIIXTXCLK ²	Tper_9d	None	39.9	40.0	ns	100 Mbps	
	Thigh_9d, Tlow_9d		14.0	26.0	ns		
	Trise_9d, Tfall_9d		—	2.0	ns		
MIIXRXD[3:0], MIIXRXDV, MIIXRXER	Tsu_9e	MIIXRXCLK rising	3.0	—	ns		
	Thld_9e		2.0	—	ns		
MIIXTXD[3:0], MIIXTXENP, MIIXTXER	Tdo_9f	MIIXTXCLK rising	5.0	13	ns		

Table 9 Ethernet AC Timing Characteristics

¹. There are two MII interfaces and the timing is the same for each. "x" represents interface 0 or 1 (For example, MIIXRXCLK can be either MII0RXCLK or MII1RXCLK).

². The ethernet clock (MIIXRXCLK and MIIXTXCLK) frequency must be equal to or less than 1/2 CLK (MIIXRXCLK and MIIXTXCLK <= 1/2(CLK)).

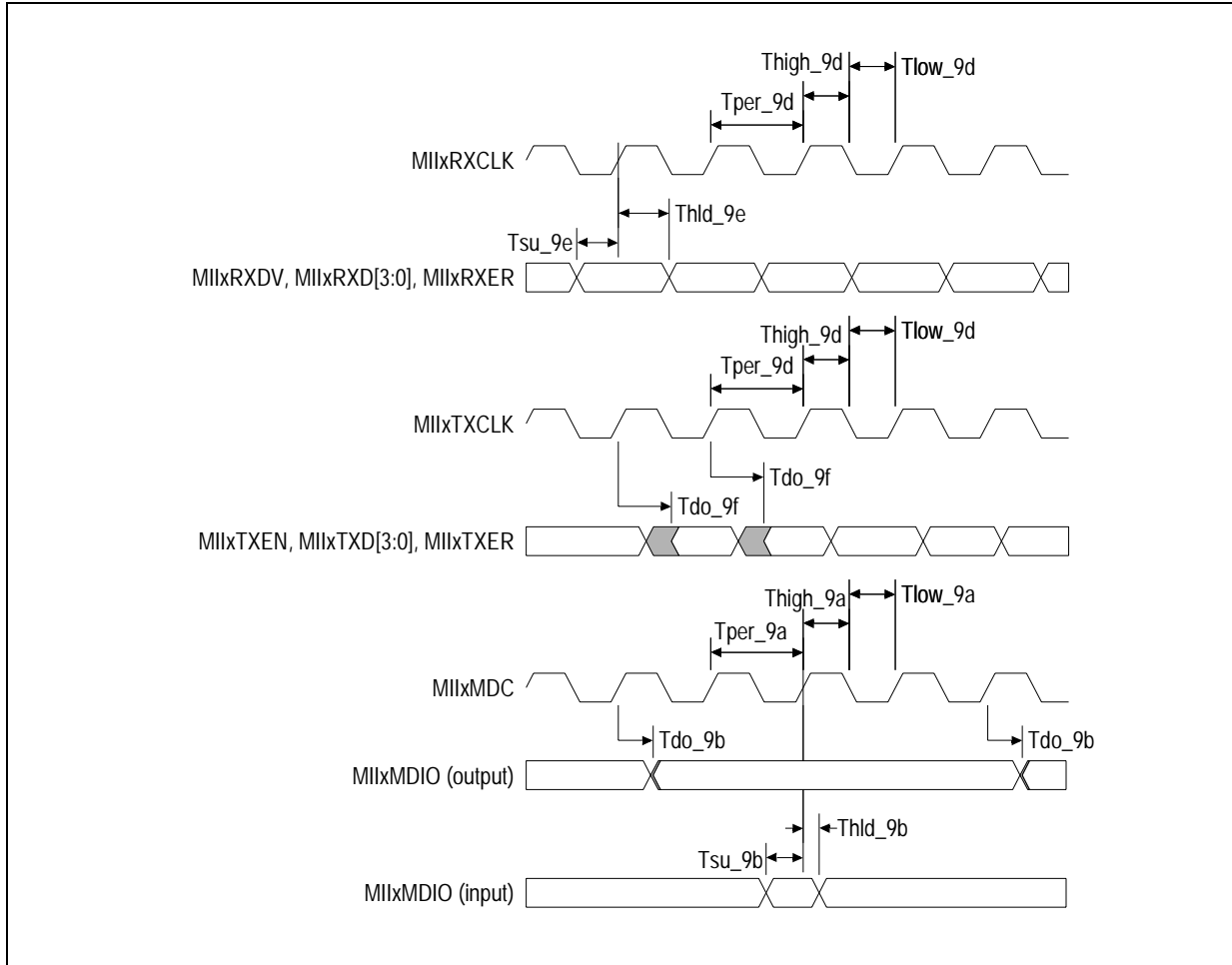

Figure 11 Ethernet AC Timing Waveform

Signal	Symbol	Reference Edge	150MHz		Unit	Conditions	Timing Diagram Reference
			Min	Max			
PCI¹							
PCICLK ²	Tper_10a	none	15.0	30.0	ns	66 MHz PCI	See Figure 12
	Thigh_10a, Tlow_10a		6.0	—	ns		
	Tslew_10a		1.5	4.0	V/ns		
PCIAD[31:0]	Tsu_10b	PCICLK rising	3.0	—	ns		
	Thld_10b		0	—	ns		
	Tdo_10b		2.0	6.0	ns		
	Tdz_10b ³		—	14.0	ns		
	Tzd_10b ³		2.0	—	ns		
PCIBEN[3:0], PCIDEVSELN, PCIFRAMEN,PCIIRDYN, PCILOCKN, PCIPAR, PCIPERRN, PCISTOPN, PCITRDY ⁴	Tsu_10b ⁵	PCICLK rising	5.0	—	ns		
	Thld_10b		0	—	ns		
	Tdo_10b		1.5	6.0	ns		
PCIGNTN[2:0], PCIREQN[2:0] ^{4,6}	Tsu_10c	PCICLK rising	5.0	—	ns		
	Thld_10c		0	—	ns		
	Tdo_10c		1.5	6.0	ns		
PCIRSTN (output) ⁷	Tpw_10d ³	None	4000 (CLK)	—	ns		See Figure 13
PCIRSTN (input) ^{7,8}	Tpw_10e ³	None	2(CLK)	—	ns		See Figure 14
	Tdz_10e ³	PCIRSTN falling	6(CLK)	—	ns		
PCISERRN ⁹	Tsu_10f	PCICLK rising	3.0	—	ns		See Figure 12
	Thld_10f		0	—	ns		
	Tzd_10f ³		2.0	6.0	ns		
PCIMUINTN ¹⁰	Tzd_10g ³	PCICLK rising	4.7	11.1	ns		

Table 10 PCI AC Timing Characteristics

- ¹ This PCI interface conforms to the PCI Local Bus Specification, Rev 2.2 at 33MHz.
- ² PCICLK must be equal to or less than two times CLK (PCICLK <= 2(CLK)).
- ³ The values for this symbol were determined by calculation, not by testing.
- ⁴ PCI Local Bus Specification, Rev 2.2 specifies Tval minimum = 2.0ns.
- ⁵ The 5ns minimum set-up time conforms to the PCI Local Bus Specification, Rev 2.2 at 33MHz. At 66MHz, the 5ns minimum set-up time provides a wide margin of 4ns, which is sufficient to ensure a working design at such frequency.
- ⁶ PCIGNTN[2] and PCIREQN[2] are alternate functions of GPIO[14] and GPIO[13] respectively.
- ⁷ PCIRSTN is an output in host mode and an input in satellite mode.
- ⁸ To meet the PCI delay specification from reset asserted to outputs floating, the PCI reset should be logically combined with the COLDRSTN input, instead of input on PCIRSTN.
- ⁹ PCISERRN uses open collector I/O types.
- ¹⁰ PCIMUINTN is an alternate function of GPIO[15].

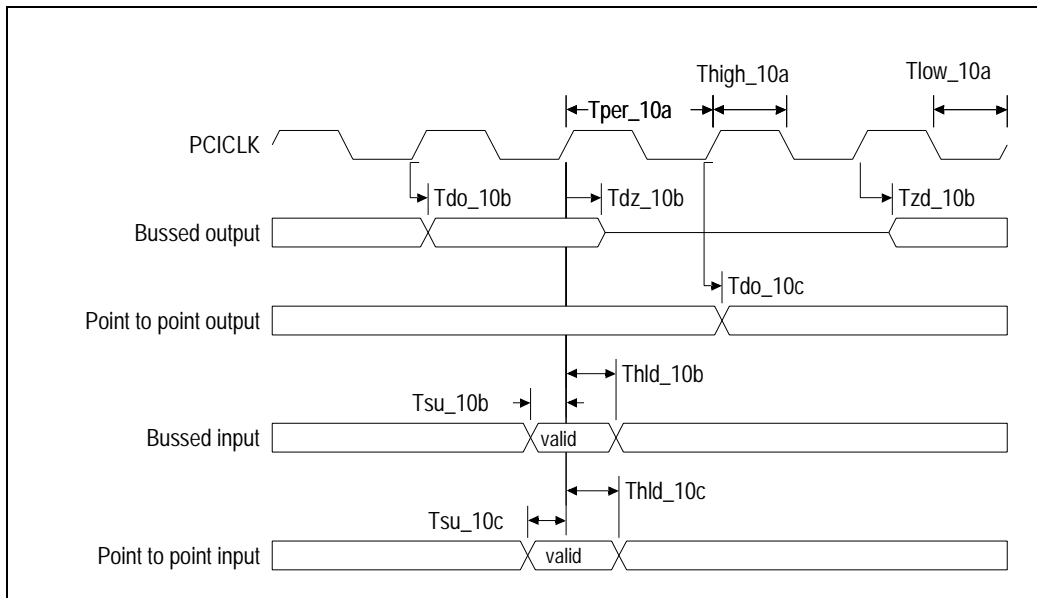

Figure 12 PCI AC Timing Waveform

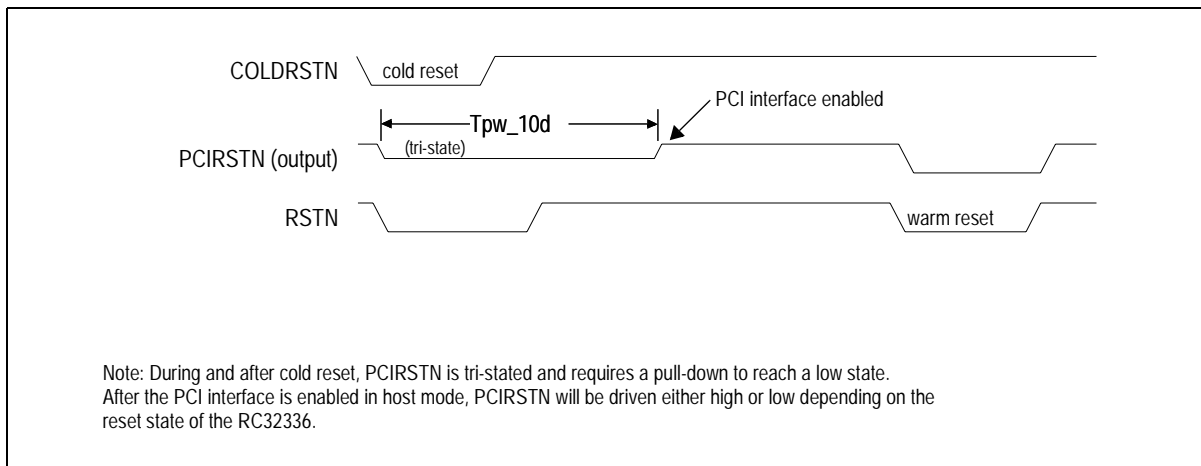

Figure 13 PCI AC Timing Waveform — PCI Reset in Host Mode

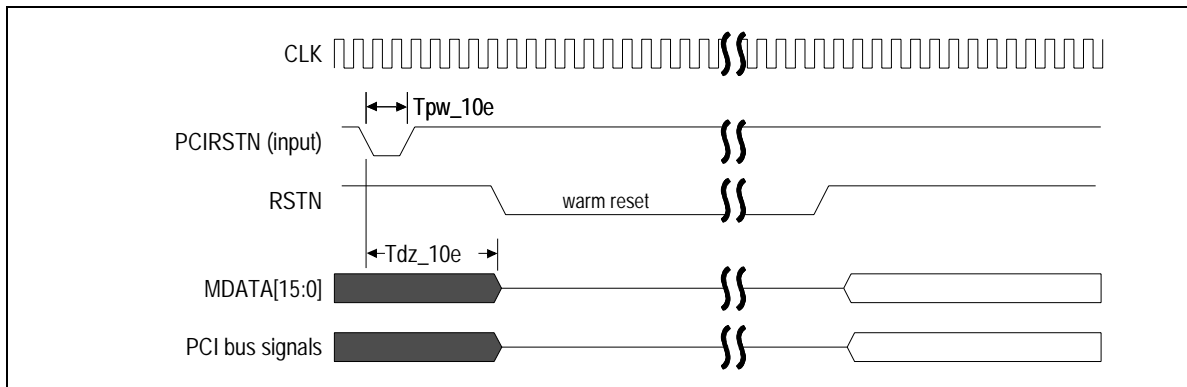

Figure 14 PCI AC Timing Waveform — PCI Reset in Satellite Mode

Signal	Symbol	Reference Edge	150MHz		Unit	Conditions	Timing Diagram Reference
			Min	Max			
SPI¹							
SCK	Tper_12a	None	—	1920	ns	33 MHz PCI	See Figures 15 through 18
	Tper_12a		—	960	ns	66 MHz PCI	
	Tper_12a		100	166667	ns	SPI	
	Thigh_12a, Tlow_12a		930	990	ns	33 MHz PCI	
	Thigh_12a, Tlow_12a		465	495	ns	66 MHz PCI	
	Thigh_12a, Tlow_12a		40	83353	ns	SPI	
SDI	Tsu_12b	SCK rising or falling	60	—	ns	SPI or PCI	
	Thld_12b		60	—	ns		
SDO	Tdo_12c	SCK rising or falling	0	60	ns	SPI or PCI	
PCIEECS ²	Tdo_12d	SCK rising or falling	0	60	ns	PCI	
SCK, SDI, SDO ³	Tpw_12e	None	2(CLK)	—	ns		

Table 11 SPI AC Timing Characteristics

¹ In SPI mode, the SCK period and sampling edge are programmable. In PCI mode, the SCK period is fixed and the sampling edge is rising.

² PCIEECS is the PCI serial EEPROM chip select. It is an alternate function of PCIGNTN[1].

³ In Bit I/O mode, SCK, SDI, and SDO must meet the setup and hold times if they are synchronous or the minimum pulse width if they are asynchronous.

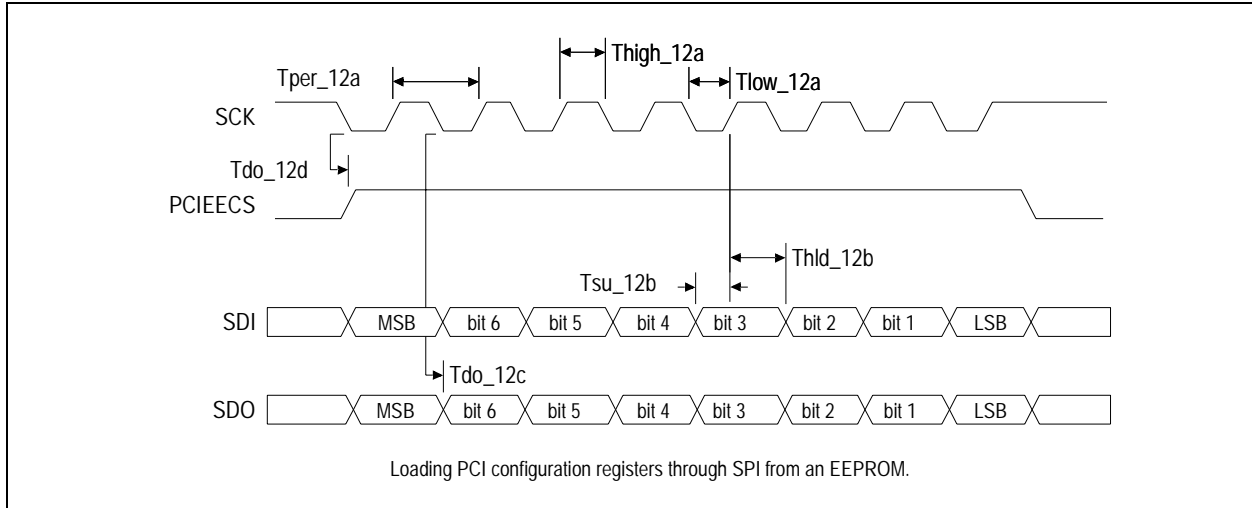

Figure 15 SPI AC Timing Waveform — PCI Configurations Load

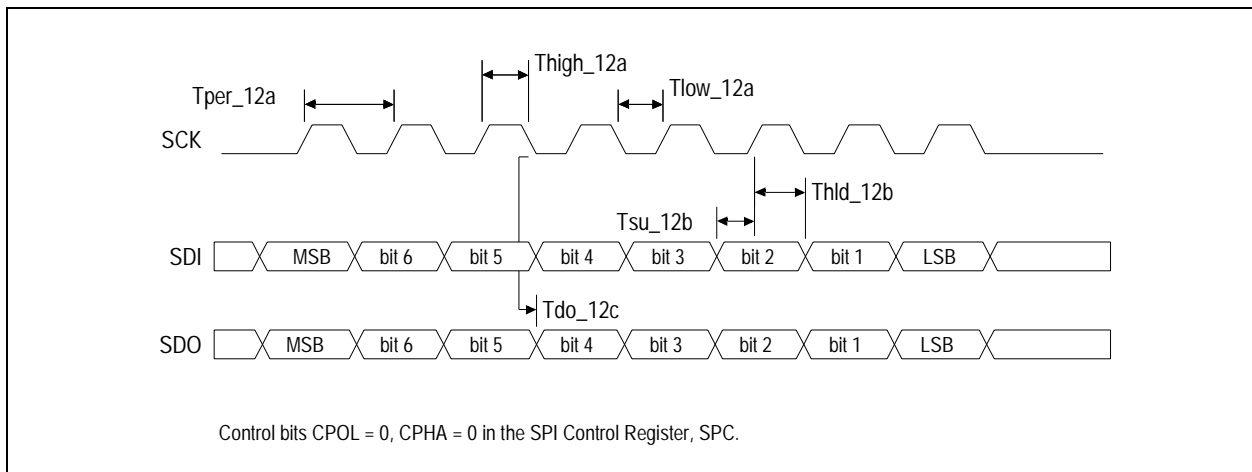

Figure 16 SPI AC Timing Waveform — Clock Polarity 0, Clock Phase 0

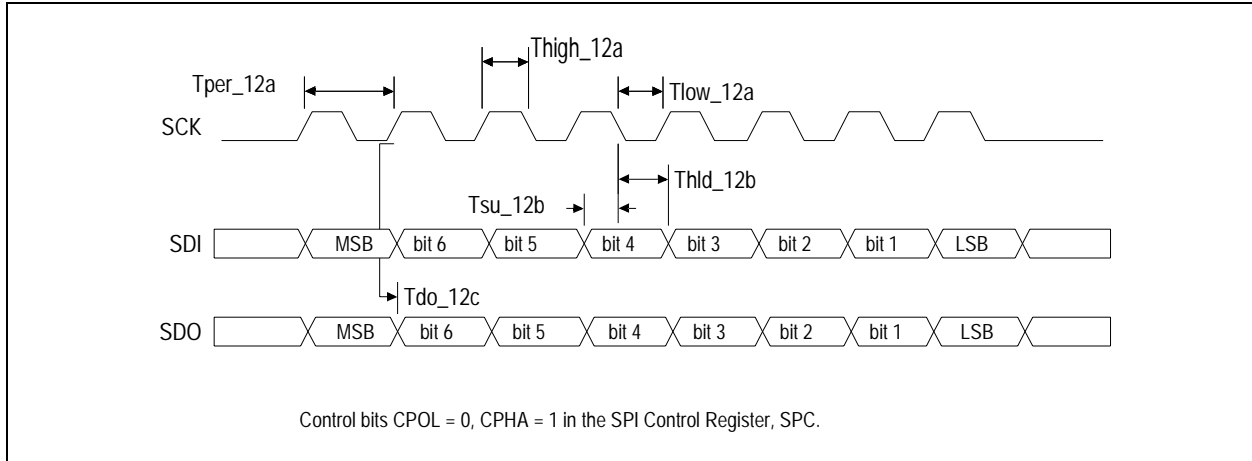

Figure 17 SPI AC Timing Waveform — Clock Polarity 0, Clock Phase 1

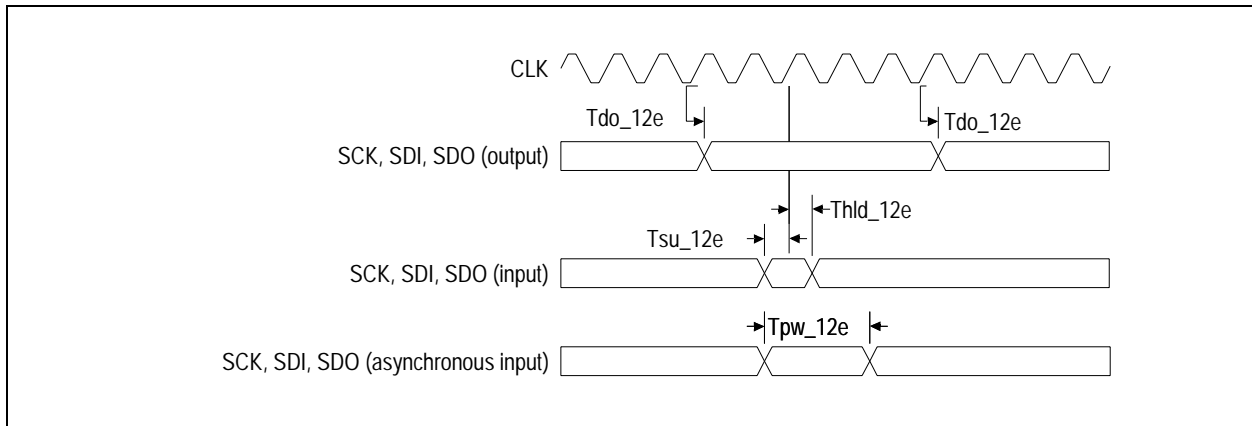

Figure 18 SPI AC Timing Waveform — Bit I/O Mode

Signal	Symbol	Reference Edge	150MHz		Unit	Conditions	Timing Diagram Reference
			Min	Max			
GPIO							
GPIO[15:0] ¹	Tsu_13a	CLK rising	4.0	—	ns		See Figure 19
	Thld_13a		2.0	—	ns		
	Tdo_13a		2.0	14.0	ns		
	Tpw_13b ²	None	2(CLK)	—	ns		

Table 12 GPIO AC Timing Characteristics

¹ GPIO signals must meet the setup and hold times if they are synchronous or the minimum pulse width if they are asynchronous.

² The values for this symbol were determined by calculation, not by testing.

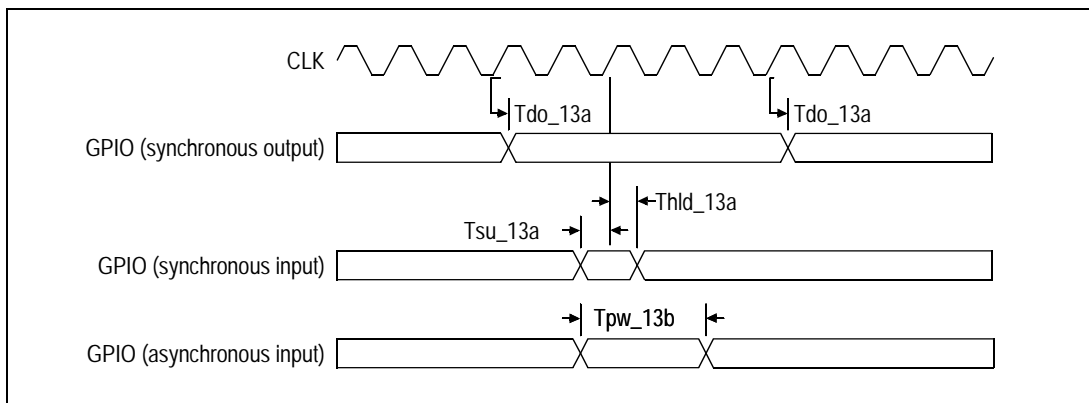

Figure 19 GPIO AC Timing Waveform

Signal	Symbol	Reference Edge	150MHz		Unit	Conditions	Timing Diagram Reference
			Min	Max			
EJTAG and JTAG							
JTAG_TCK	Tper_14a	none	100	—	ns		See Figure 20
	Thigh_14a, Tlow_14a		40	—	ns		
	Trise_14a, Tfall_14a		—	5.0	ns		
JTAG_TDI	Tsu_14b	JTAG_TCK rising	4.0	—	ns		
	Thld_14b		4.0	—	ns		
JTAG_TMS	Tsu_14c		4.0	—	ns		
	Thld_14c		4.0	—	ns		
EJTAG_TMS	Tsu_14d		4.0	—	ns		
	Thld_14d		4.0	—	ns		
JTAG_TDO	Tdo_14e	JTAG_TCK falling	—	12.5	ns		
	Tdz_14e ¹		—	15.0	ns		
JTAG_TRST_N	Tpw_14f ¹	none	100	—	ns		
VSENSE	Trise_16f	none	—	2	sec	Measured from 0.5V (T _{active})	See Figure 22

Table 13 EJTAG/JTAG AC Timing Characteristics

¹. The values for this symbol were determined by calculation, not by testing.

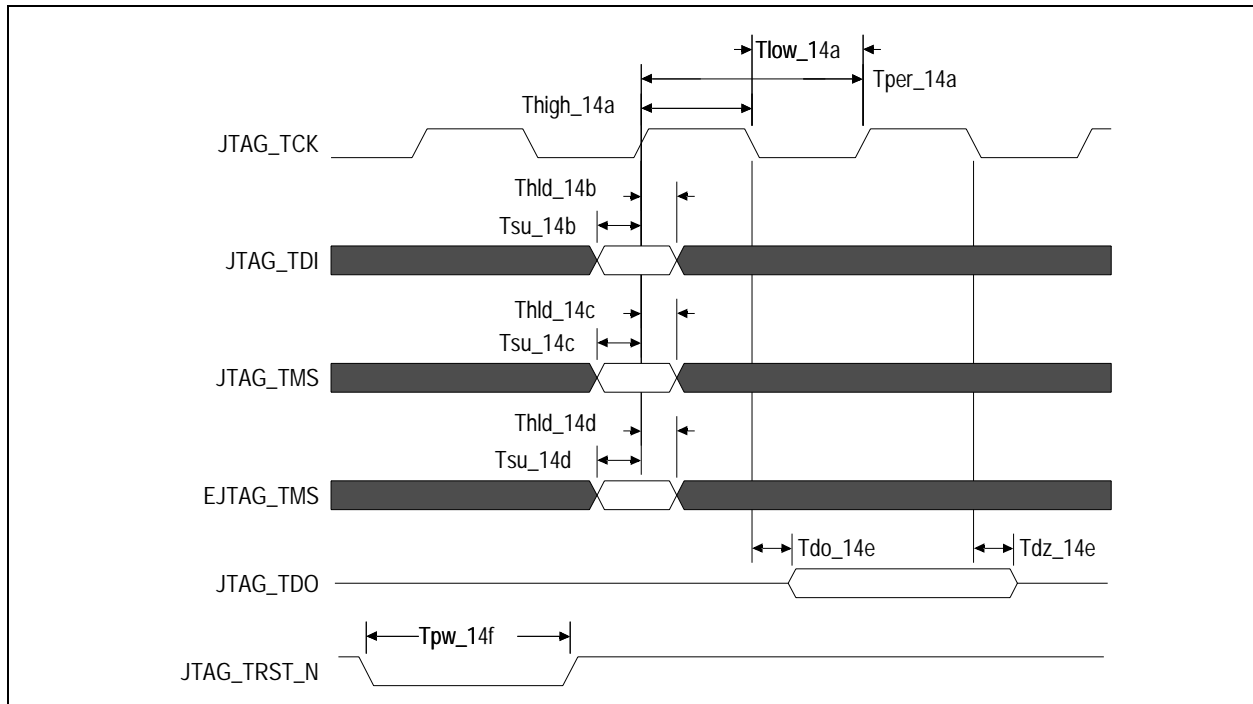

Figure 20 EJTAG/JTAG AC Timing Waveform

The IEEE 1149.1 specification requires that the JTAG and EJTAG TAP controllers be reset at power-up whether or not the interfaces are used for a boundary scan or a probe. Reset can occur through a pull-down resistor on JTAG_TRST_N if the probe is not connected. However, on-chip pull-up resistors are implemented on the RC32336 due to an IEEE 1149.1 requirement. Having on-chip pull-up and external pull-down resistors for the JTAG_TRST_N signal requires special care in the design to ensure that a valid logical level is provided to JTAG_TRST_N, such as using a small external pull-down resistor to ensure this level overrides the on-chip pull-up. An alternative is to use an active power-up reset circuit for JTAG_TRST_N, which drives JTAG_TRST_N low only at power-up and then holds JTAG_TRST_N high afterwards with a pull-up resistor.

Figure 21 shows the electrical connection of the EJTAG probe target system connector.

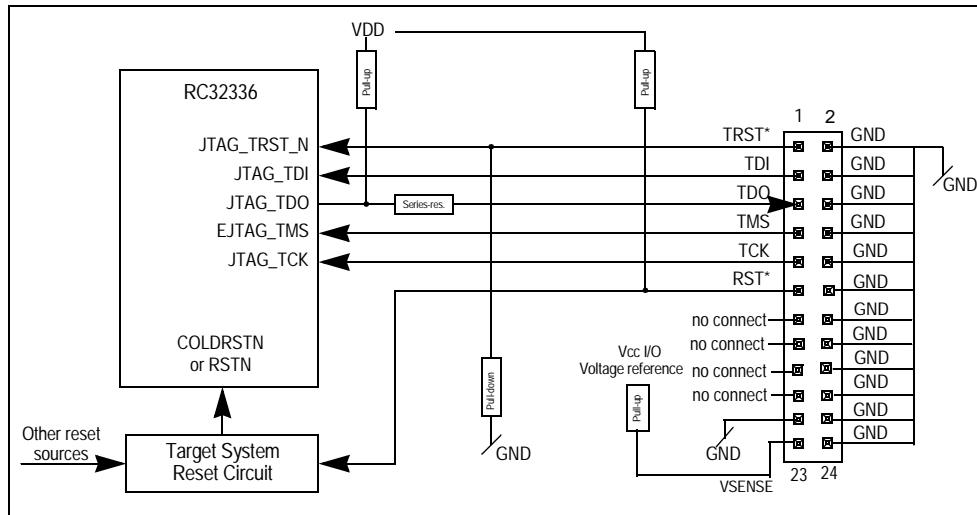

Figure 21 Target System Electrical EJTAG Connection

Using the EJTAG Probe

In Figure 21, the pull-up resistors for JTAG_TDO and RST*, the pull-down resistor for JTAG_TRST_N, and the series resistor for JTAG_TDO must be adjusted to the specific design. However, the recommended pull-up/down resistor is 1.0 k Ω because a low value reduces crosstalk on the cable to the connector, allowing higher JTAG_TCK frequencies. A typical value for the series resistor is 33 Ω . Recommended resistor values have $\pm 5\%$ tolerance.

If a probe is used, the pull-up resistor on JTAG_TDO must ensure that the JTAG_TDO level is high when no probe is connected and the JTAG_TDO output is tri-stated. This requirement allows reliable connection of the probe if it is hooked-up when the power is already on (hot plug). The pull-up resistor value of around 47 k Ω should be sufficient. Optional diodes to protect against overshoot and undershoot voltage can be added on the signals of the chip with EJTAG.

If a probe is used, the RST* signal must have a pull-up resistor because it is controlled by an open-collector (OC) driver in the probe, and thus is actively pulled low only. The pull-up resistor is responsible for the high value when not driven by the probe of 25pF. The input on the target system reset circuit must be able to accept the rise time when the pull-up resistor charges the capacitance to a high logical level. Vcc I/O must connect to a voltage reference that drops rapidly to below 0.5V when the target system loses power, even with a capacitive load of 25pF. The probe can thus detect the lost power condition.

For additional information on EJTAG, refer to Chapter 23 of the RC32336 User Reference Manual.

Voltage Sense Signal Timing

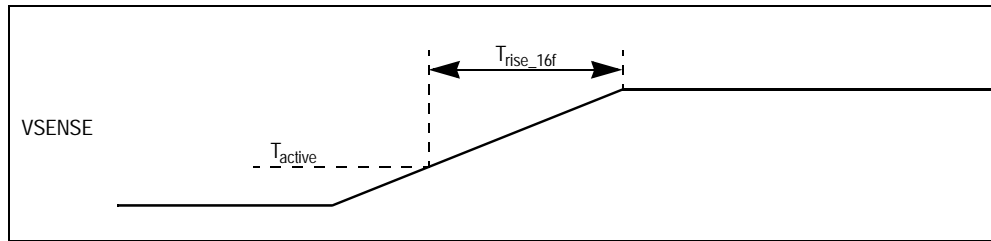

Figure 22 Voltage Sense Signal Timing

The target system must ensure that T_{rise} is obeyed after the system reaches 0.5V (T_{active}), so the probe can use this value to determine when the target has powered-up. The probe is allowed to measure the T_{rise} time from a higher value than T_{active} (but lower than V_{cc} I/O minimum) because the stable indication in this case comes later than the time when target power is guaranteed to be stable. If JTAG_TRST_N is asserted by a pulse at power-up, this reset must be completed after T_{rise} . If JTAG_TRST_N is asserted by a pull-down resistor, the probe will control JTAG_TRST_N. At power-down, no power is indicated to the probe when V_{cc} I/O drops under the T_{active} value, which the probe uses to stop driving the input signals, except for the probe RST*.

AC Test Conditions

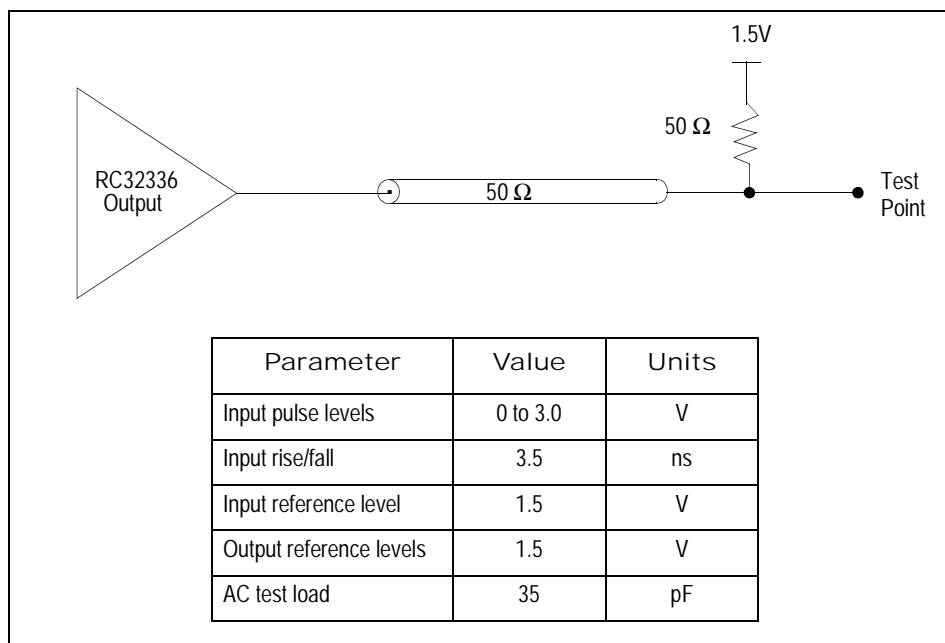

Figure 23 Output Loading for AC Timing

Phase-Locked Loop (PLL)

The processor aligns the pipeline clock, PClock, to the master input clock (CLK) by using an internal phase-locked loop (PLL) circuit that generates aligned clocks. Inherently, PLL circuits are only capable of generating aligned clocks for master input clock (CLK) frequencies within a limited range.

PLL Analog Filter

The storage capacitor required for the Phase-Locked Loop circuit is contained in the RC32336. However, it is recommended that the system designer provide a filter network of passive components for the PLL power supply.

V_{CC_PLL} (circuit power) and V_{SS_PLL} (circuit ground) should be isolated from V_{CC} Core (core power) and V_{SS} (common ground) with a filter circuit such as the one shown in Figure 24.

Because the optimum values for the filter components depend upon the application and the system noise environment, these values should be considered as starting points for further experimentation within your specific application.

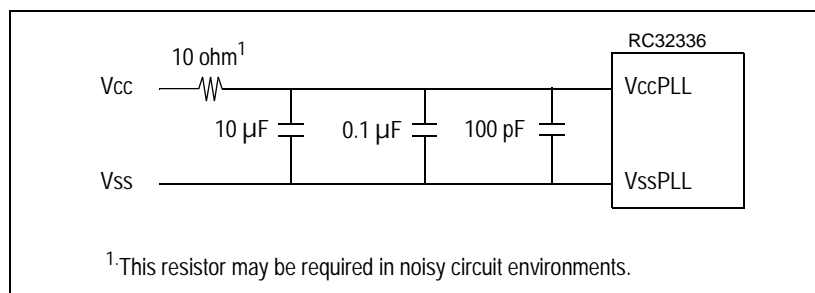

Figure 24 PLL Filter Circuit for Noisy Environments

Recommended Operating Supply Voltages

Symbol	Parameter	Minimum	Typical	Maximum	Unit
V_{SS}	Common ground	0	0	0	V
V_{SS}^{PLL}	PLL ground				
$V_{CC}^{I/O}$	I/O supply	3.135	3.3	3.465	
V_{CC}^{Core}	Internal logic supply	2.375	2.5	2.625	
V_{CC}^{PLL}	PLL supply				

Table 14 RC32336 Operating Supply Voltages

Recommended Operating Temperatures

Grade	Temperature
Commercial	0°C+ 70°C Ambient
Industrial	-40°C+ 85°C Ambient

Table 15 RC32336 Operating Temperature

Capacitive Load Deration

Refer to the [RC32336 IBIS Model](#) which can be found at the IDT web site (www.idt.com).

Power-on RampUp

The 2.5V V_{CC}^{Core} and V_{CC}^{PLL} supplies can be fully powered without the 3.3V $V_{CC}^{I/O}$ supply. However, the $V_{CC}^{I/O}$ supply cannot exceed the V_{CC}^{Core} and V_{CC}^{PLL} supplies by more than 1 volt during power up. A sustained large power difference could potentially damage the part. Inputs should not be driven until the part is fully powered. Specifically, the input high voltages should not be applied until the $V_{CC}^{I/O}$ supply is powered.

There is no special requirement for how fast $V_{CC}^{I/O}$ ramps up to 3.3V. However, all timing references are based on a stable $V_{CC}^{I/O}$.

DC Electrical Characteristics

The values given below are based on systems running at recommended supply voltages, as shown in Table 14.

Note: For a complete list of I/O types, see Table 2.

	Parameter	Min	Max	Unit	Conditions
LOW Drive Output with Schmitt Trigger Input (STI)	I_{OL}	—	7.3	mA	$V_{OL} = 0.4V$
	I_{OH}	—	-8.0	mA	$V_{OH} = (V_{CC}/O - 0.4)$
	V_{IL}	—	0.8	V	—
	V_{IH}	2.0	$(V_{CC}/O + 0.5)$	V	—
HIGH Drive Output with Standard Input	I_{OL}	—	9.4	mA	$V_{OL} = 0.4V$
	I_{OH}	—	-15	mA	$V_{OH} = (V_{CC}/O - 0.4)$
	V_{IL}	—	0.8	V	—
	V_{IH}	2.0	$(V_{CC}/O + 0.5)$	V	—
Clock Drive Output	I_{OL}	39	—	mA	$V_{OL} = 0.4V$
	I_{OH}	-24	—	mA	$V_{OH} = (V_{CC}/O - 0.4)$
PCI	$I_{OH}(AC)$ Switching	$-12(V_{CC}/O)$	—	mA	$0 < V_{OUT} < 0.3(V_{CC}/O)$
		$-17.1(V_{CC}/O - V_{OUT})$	—	mA	$0.3(V_{CC}/O) < V_{OUT} < 0.9(V_{CC}/O)$
		—	$-32(V_{CC}/O)$	mA	$0.7(V_{CC}/O)$
	$I_{OL}(AC)$ Switching	$+16(V_{CC}/O)$	—	mA	$V_{CC}/O > V_{OUT} > 0.6(V_{CC}/O)$
		$+26.7(V_{OUT})$	—	mA	$0.6(V_{CC}/O) > V_{OUT} > 0.1(V_{CC}/O)$
		—	$+38(V_{CC}/O)$	mA	$V_{OUT} = 0.18(V_{CC}/O)$
	V_{IL}	-0.3	$0.3(V_{CC}/O)$	V	—
V_{IH}	$0.5(V_{CC}/O)$	5.5	V	—	
Capacitance	C_{IN}	—	10	pF	—
Leakage	I/O_{LEAK}	—	20	μA	—

Table 16 DC Electrical Characteristics

Power Consumption

Parameter		150MHz		Unit	Conditions
		Typical	Max.		
I_{cc}/O		60	80	mA	$C_L = 25pF$ (affects I/O) $T_a = 25^{\circ}C$ Maximum values use the maximum voltages listed in Table 14. Typical values use the typical voltages listed in Table 14.
$I_{cc}Core$	Normal mode	710	750	mA	
	Standby mode ¹	620	660	mA	
Power Dissipation	Normal mode	2.07	2.2	W	
	Standby mode ¹	1.8	2.0	W	

Table 17 RC32336 Power Consumption

¹. RISCore 32300 CPU core enters Standby mode by executing WAIT instructions; however, other logic continues to function. Standby mode reduces power consumption by 0.6 mA per MHz of the CPU pipeline clock, PCLK.

Power Curve

The following graph contains a power curve that shows power consumption at various bus frequencies.

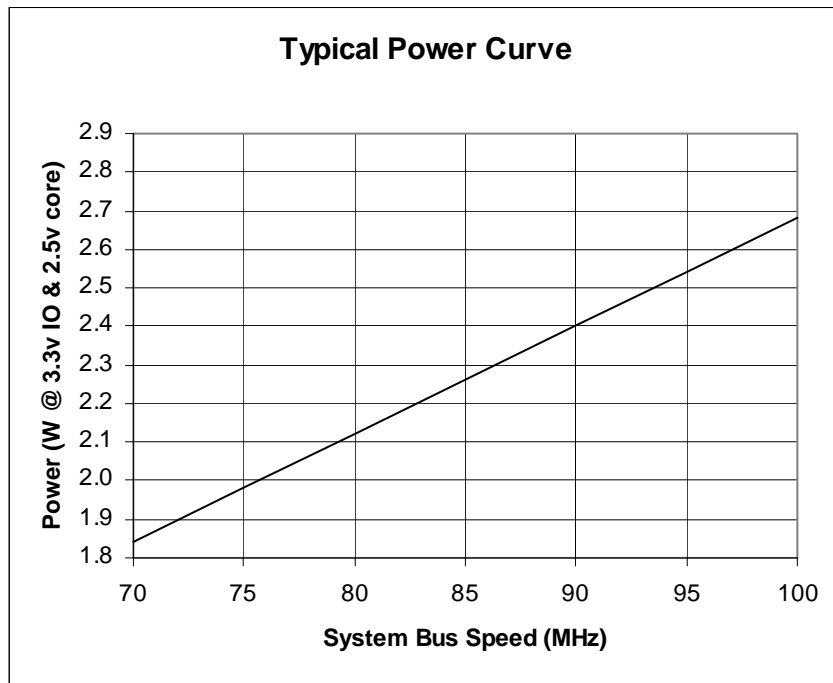

Figure 25 Typical Power Usage

Absolute Maximum Ratings

Symbol	Parameter	Min ¹	Max ¹	Unit
V _{CC} I/O	I/O Supply Voltage	-0.6	4.0	V
V _{CC} Core	Core Supply Voltage	-0.3	3.0	V
V _{CC} PLL	PLL Supply Voltage	-0.3	3.0	V
V _{imin}	Input Voltage - undershoot	-0.6	—	V
V _i	I/O Input Voltage	Gnd	V _{CC} I/O+0.6	V
T _a , Industrial	Ambient Operating Temperature	-40	+85	°C
T _a , Commercial	Ambient Operating Temperature	0	+70	°C
T _{stg}	Storage Temperature	-40	+125	°C

Table 18 Absolute Maximum Ratings

¹ Functional and tested operating conditions are given in Table 14. Absolute maximum ratings are stress ratings only, and functional operation at the maximums is not guaranteed. Stresses beyond those listed may affect device reliability or cause permanent damage to the device.

Package Pin-out — 256-Pin CABGA

The following table lists the pin numbers and signal names for the RC32336.

Pin	Function	Alt	Pin	Function	Alt	Pin	Function	Alt	Pin	Function	Alt
A1	MII0RXD[0]		E1	GPIO[15]	1	J1	PCIGNTN[1]		N1	PCIAD[4]	
A2	MII0RXDV		E2	JTAG_TRST_N		J2	PCIDEVSELN		N2	PCIAD[20]	
A3	MII0RXER		E3	JTAG_TDO		J3	PCIGNTN[0]		N3	PCIAD[19]	
A4	MII0TXCLK		E4	JTAG_TDI		J4	PCIFRAMEN		N4	PCIAD[11]	
A5	MII0TXD[2]		E5	V _{cc} CORE		J5	V _{cc} I/O		N5	PCIAD[13]	
A6	MII0CRS		E6	V _{cc} I/O		J6	V _{ss}		N6	PCIAD[15]	
A7	V _{ss} PLL		E7	V _{cc} I/O		J7	V _{ss}		N7	BOEN[0]	
A8	MII1RXCLK		E8	V _{cc} I/O		J8	V _{ss}		N8	CSN[2]	
A9	MII1TXD[2]		E9	V _{cc} I/O		J9	V _{ss}		N9	CSN[3]	
A10	MII1CL		E10	V _{cc} I/O		J10	V _{ss}		N10	RWN	
A11	JTAG_TCK		E11	V _{cc} I/O		J11	V _{ss}		N11	MDATA[1]	
A12	GPIO[9]	1	E12	V _{cc} CORE		J12	V _{cc} I/O		N12	MDATA[3]	
A13	GPIO[5]	1	E13	MADDR[5]		J13	SDWEN		N13	MDATA[12]	
A14	GPIO[3]	1	E14	MADDR[16]		J14	SDCLKINP		N14	MDATA[30]	
A15	GPIO[1]	1	E15	MADDR[17]		J15	BWEN[2]		N15	MDATA[11]	
A16	MADDR[10]		E16	MADDR[6]		J16	BWEN[3]		N16	MDATA[27]	
B1	MII0RXD[3]		F1	GPIO[14]	1	K1	PCICBEN[1]		P1	PCIAD[5]	
B2	MII0RXD[1]		F2	GPIO[13]	1	K2	PCICBEN[2]		P2	PCIAD[21]	
B3	MII0RXCLK		F3	PCITRDYN		K3	PCICBEN[0]		P3	PCIAD[23]	
B4	MII0TXER		F4	PCISTOPN		K4	PCICLK		P4	PCIAD[10]	
B5	MII0TXD[3]		F5	V _{cc} CORE		K5	V _{cc} I/O		P5	PCIAD[28]	
B6	MII0CL		F6	V _{cc} I/O		K6	V _{ss}		P6	PCIAD[30]	
B7	V _{cc} PLL		F7	V _{ss}		K7	V _{ss}		P7	BDIRN	
B8	MII1RXDV		F8	V _{ss}		K8	V _{ss}		P8	CSN[1]	
B9	MII1TXD[3]		F9	V _{ss}		K9	V _{ss}		P9	CSN[4]	
B10	MII1CRS		F10	V _{ss}		K10	V _{ss}		P10	WAITACKN	
B11	GPIO[12]	1	F11	V _{cc} I/O		K11	V _{ss}		P11	MDATA[17]	
B12	GPIO[8]	1	F12	V _{cc} CORE		K12	V _{cc} CORE		P12	MDATA[19]	
B13	GPIO[4]	1	F13	MADDR[3]		K13	BWEN[1]		P13	MDATA[5]	
B14	GPIO[2]	1	F14	MADDR[14]		K14	RASN		P14	MDATA[9]	
B15	MADDR[21]		F15	MADDR[15]		K15	CASN		P15	MDATA[10]	
B16	MADDR[20]		F16	MADDR[4]		K16	BWEN[0]		P16	MDATA[26]	
C1	MIIIMDC		G1	PCIRSTN		L1	PCIAD[16]		R1	PCIAD[6]	
C2	MIIIMDIO		G2	PCISERRN		L2	PCIAD[1]		R2	PCIAD[7]	

Table 19: 256-pin CABGA Package Pin-Out (Part 1 of 2)

Pin	Function	Alt	Pin	Function	Alt	Pin	Function	Alt	Pin	Function	Alt
C3	MII0RXD[2]		G3	PCIPERRN		L3	PCIAD[0]		R3	PCIAD[24]	
C4	MII0TXENP		G4	PCIREQN[0]		L4	PCICBEN[3]		R4	PCIAD[25]	
C5	MII0TXD[1]		G5	V _{cc} CORE		L5	V _{cc} CORE		R5	PCIAD[27]	
C6	MII1RXD[3]		G6	V _{ss}		L6	V _{cc} I/O		R6	PCIAD[29]	
C7	MII1RXD[0]		G7	V _{ss}		L7	V _{ss}		R7	PCIAD[31]	
C8	MII1RXER		G8	V _{ss}		L8	V _{ss}		R8	BOEN[1]	
C9	MII1TXENP		G9	V _{ss}		L9	V _{ss}		R9	OEN	
C10	MII1TXD[0]		G10	V _{ss}		L10	V _{ss}		R10	MDATA[16]	
C11	EJTAG_TMS		G11	V _{ss}		L11	V _{cc} I/O		R11	MDATA[18]	
C12	GPIO[10]	1	G12	V _{cc} I/O		L12	V _{cc} CORE		R12	MDATA[20]	
C13	GPIO[6]		G13	MADDR[1]		L13	CLK		R13	MDATA[21]	
C14	GPIO[0]	1	G14	MADDR[12]		L14	SDCLKOUT		R14	MDATA[7]	
C15	MADDR[9]		G15	MADDR[13]		L15	MDATA[15]		R15	MDATA[24]	
C16	MADDR[19]		G16	MADDR[2]		L16	MDATA[31]		R16	MDATA[25]	
D1	SDI		H1	PCIPAR		M1	PCIAD[18]		T1	PCIAD[22]	
D2	COLDRSTN		H2	PCIREQN[1]		M2	PCIAD[3]		T2	PCIAD[8]	
D3	SDO		H3	PCILCKN		M3	PCIAD[2]		T3	PCIAD[9]	
D4	SCK		H4	PCIRDYN		M4	PCIAD[17]		T4	PCIAD[26]	
D5	MII0TXD[0]		H5	V _{cc} I/O		M5	V _{cc} CORE		T5	PCIAD[12]	
D6	MII1RXD[2]		H6	V _{ss}		M6	V _{cc} I/O		T6	PCIAD[14]	
D7	MII1RXD[1]		H7	V _{ss}		M7	V _{cc} I/O		T7	RSTN	
D8	MII1TXER		H8	V _{ss}		M8	V _{cc} I/O		T8	CSN[0]	
D9	MII1TXCLK		H9	V _{ss}		M9	V _{cc} I/O		T9	CSN[5]	
D10	MII1TXD[1]		H10	V _{ss}		M10	V _{cc} I/O		T10	MDATA[0]	
D11	JTAG_TMS		H11	V _{ss}		M11	V _{cc} I/O		T11	MDATA[2]	
D12	GPIO[11]	1	H12	V _{cc} I/O		M12	V _{cc} CORE		T12	MDATA[4]	
D13	GPIO[7]	1	H13	SDCSN[0]		M13	MDATA[14]		T13	MDATA[6]	
D14	MADDR[7]		H14	SDCSN[1]		M14	MDATA[13]		T14	MDATA[22]	
D15	MADDR[18]		H15	MADDR[11]		M15	MDATA[28]		T15	MDATA[23]	
D16	MADDR[8]		H16	MADDR[0]		M16	MDATA[29]		T16	MDATA[8]	

Table 19: 256-pin CABGA Package Pin-Out (Part 2 of 2)

RC32336 Power Pins

V_{CC} I/O	V_{CC} I/O	V_{CC} Core	V_{CC} PLL
E6	J5	E5	B7
E7	J12	E12	
E8	K5	F5	
E9	L6	F12	
E10	L11	G5	
E11	M6	K12	
F6	M7	L5	
F11	M8	L12	
G12	M9	M5	
H5	M10	M12	
H12	M11		

Table 20 RC32336 Power Pins

RC32336 Ground Pins

V_{SS}	V_{SS}	V_{SS}	V_{SS} PLL
F7	H7	K6	A7
F8	H8	K7	
F9	H9	K8	
F10	H10	K9	
G6	H11	K10	
G7	J6	K11	
G8	J7	L7	
G9	J8	L8	
G10	J9	L9	
G11	J10	L10	
H6	J11		

Table 21 RC32336 Ground Pins



Alternate Pin Functions

Pin	Primary	Alt #1
C14	GPIO[0]	U0SOUT
A15	GPIO[1]	U0SINP
B14	GPIO[2]	MADDR[22]
A14	GPIO[3]	MADDR[23]
B13	GPIO[4]	MADDR[24]
A13	GPIO[5]	MADDR[25]
D13	GPIO[7]	SDCKENP
B12	GPIO[8]	CEN1
A12	GPIO[9]	CEN2
C12	GPIO[10]	REGN
D12	GPIO[11]	IORDN
B11	GPIO[12]	IOWRN
F2	GPIO[13]	PCIREQN[2]
F1	GPIO[14]	PCIGNTN[2]
E1	GPIO[15]	PCIMUNITN

Table 22 Alternate Pin Functions

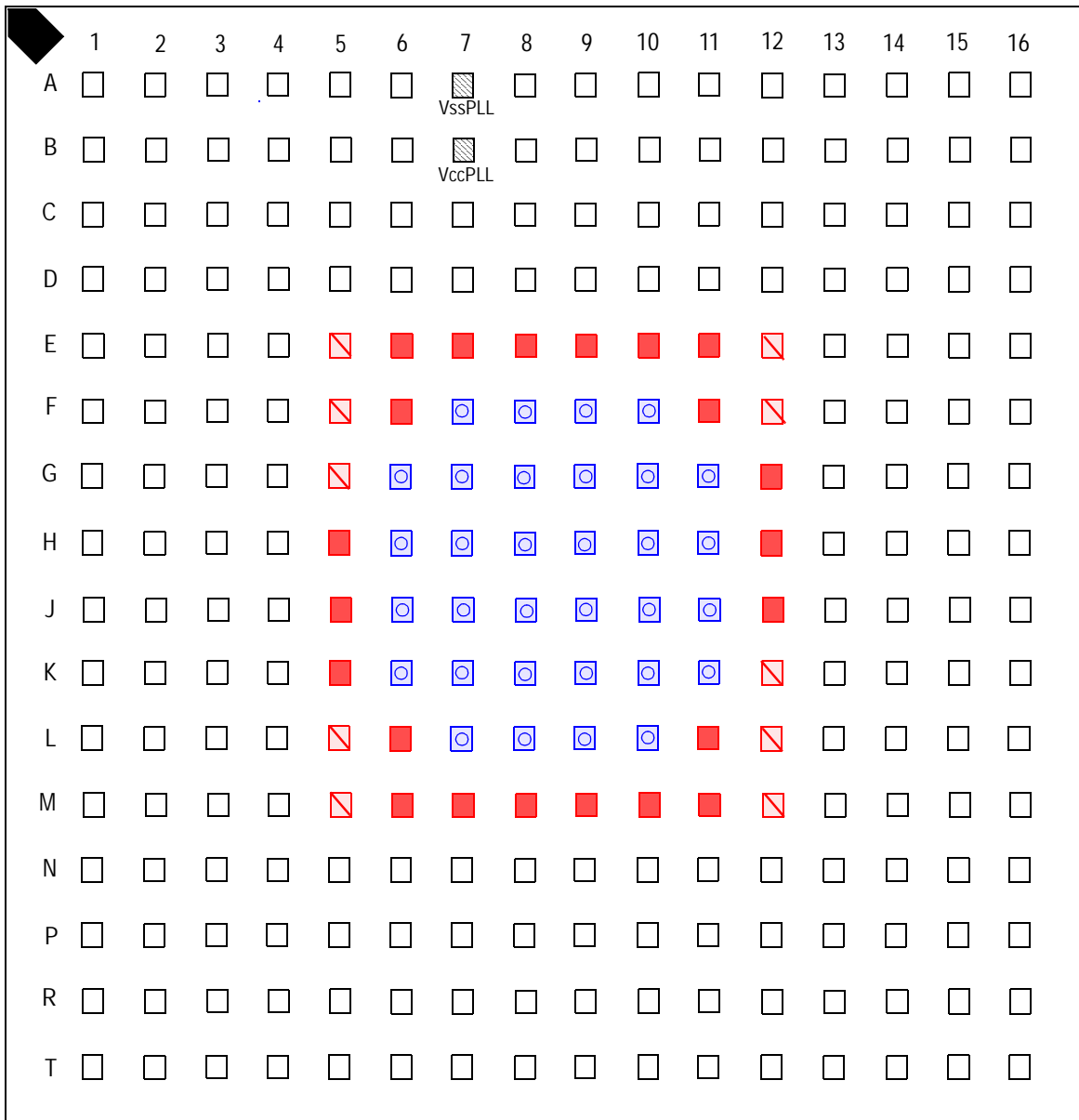
RC32336 Pinout — Top View



-  V_{SS} (Ground)
-  $V_{CC}/I/O$ (Power)
-  $V_{CC}Core$ (Power)

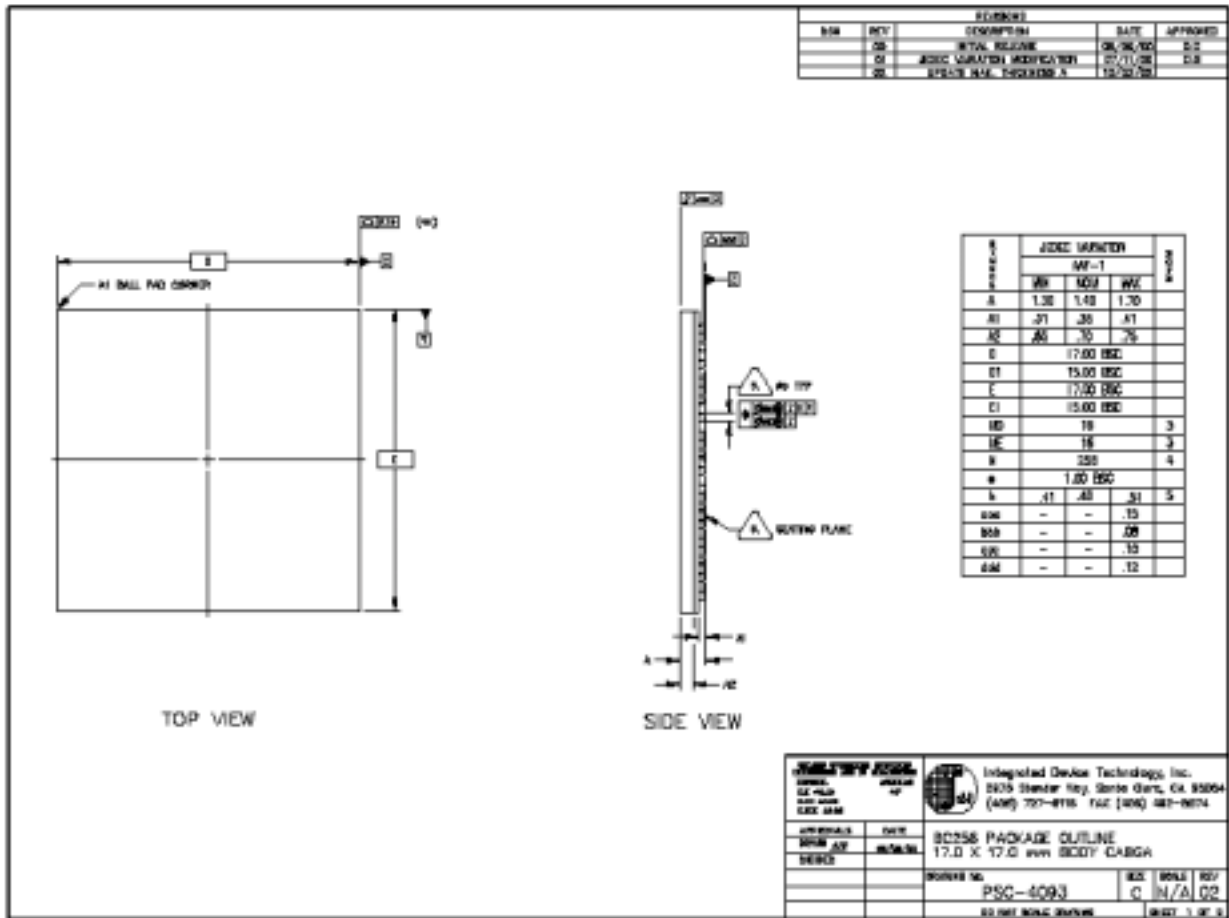

Package Drawing - 256-pin CABGA

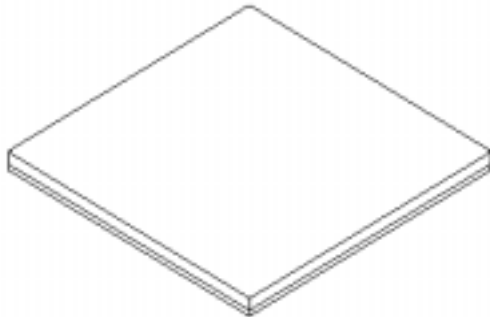

Package Drawing - page two



NOTES: UNLESS OTHERWISE SPECIFIED

1. ALL DIMENSIONS AND TOLERANCES CONFORM TO ASME Y14.5M-1994.
2. "a" REPRESENTS THE BASIC SOLDER BALL GRID PITCH.
3. "MD" IS THE MAXIMUM SOLDER BALL MATRIX SIZE IN THE "D" DIRECTION.
"ME" IS THE MAXIMUM SOLDER BALL MATRIX SIZE IN THE "E" DIRECTION.
"N" IS THE MAXIMUM ALLOWABLE NUMBER OF SOLDER BALLS.
4.  DIMENSION "N" IS MEASURED AT THE MAXIMUM SOLDER BALL DIAMETER, PARALLEL TO PRIMARY DATUM Z.
5.  PRIMARY DATUM Z AND SEATING PLANE ARE DEFINED BY THE SPHERICAL CROWNS OF THE SOLDER BALLS.
6. "A1" ID CORNER MUST BE IDENTIFIED. IDENTIFICATION MAY BE BY MEANS OF CHAMFER, METALLIZED OR INK MARK, INDENTATION OR OTHER FEATURE OF THE PACKAGE BODY.
7. ALL DIMENSIONS ARE IN MILLIMETERS.
8. THIS DRAWING CONFORMS TO JEDEC PUBLICATION 93 REGISTRATION NO-192 VARIATION AAF-1
EXCEPTIONS:
b MIN=0.41 NOM=0.46 MAX=0.51

REVISIONS				
QDR	REV	DESCRIPTION	DATE	APPROVED
	01	INITIAL DESIGN	08/20/00	J.R.
	02	ATCA VARIATION MODIFICATION	02/21/02	D.R.
	03	UPDATE WALL THICKNESS A	10/30/02	

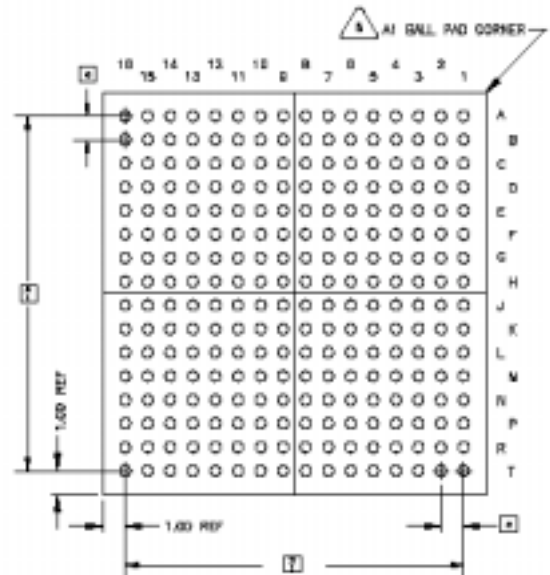

BOTTOM VIEW
200 SOLDER BALLS

 Integrated Device Technology, Inc. 2875 Steeles Hwy., Markham, ON, Canada (416) 737-4116 FAX (416) 492-8074	
APPROVED: _____ DATE: 08/20/00 DRAWN: J.R. CHECKED: _____	BC256 PACKAGE OUTLINE 17.0 X 17.0 mm BODY CARGA
DRAWING NO. PSC-4093	SIZE: C SCALE: N/A REV: 02
02 REV. 02/21/02	

Ordering Information

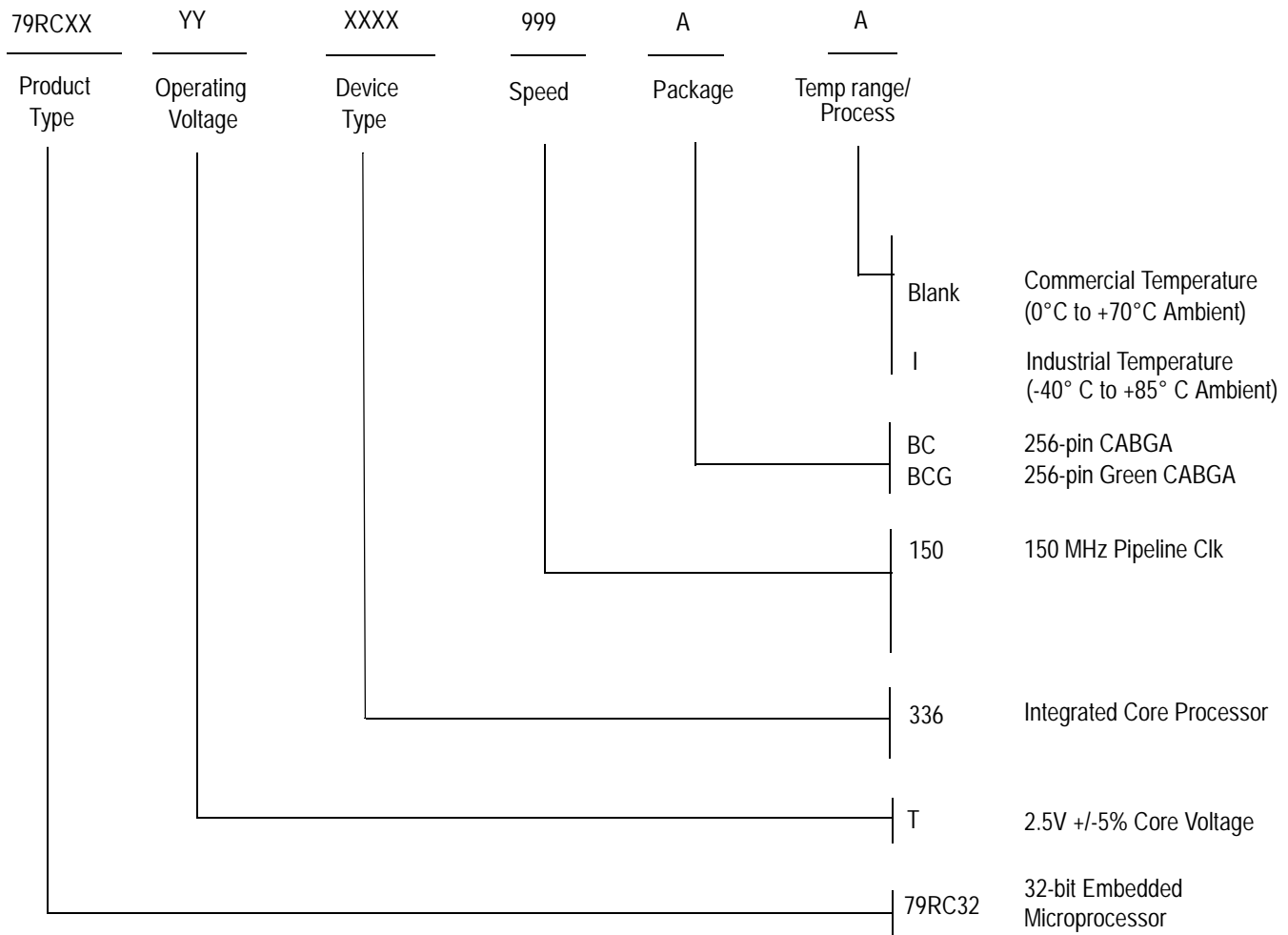

Valid Combinations

79RC32T336 - 150BC	256-pin CABGA package, Commercial Temperature
79RC32T336 - 150BCG	256-pin CABGA package, Commercial Temperature (Green)
79RC32T336 - 150BCI	256-pin CABGA package, Industrial Temperature
79RC32T336 - 150BCGI	256-pin CABGA package, Industrial Temperature (Green)



CORPORATE HEADQUARTERS
 6024 Silver Creek Valley Road
 San Jose, CA 95138

for SALES:
 800-345-7015 or 408-284-8200
 fax: 408-284-2775
 www.idt.com

for Tech Support:
 email: rischelp@idt.com
 phone: 408-284-8208