

# 75MHZ, LVCMOS/LVTTL OSCILLATOR REPLACEMENT

ICS840-275

## GENERAL DESCRIPTION



The ICS840-275 is a SAS/SATA Oscillator Replacement and a member of the HiPerClocks™ family of high performance devices from IDT. The ICS840-275 uses a 25MHz crystal to synthesize 75MHz. The ICS840-275 has excellent jitter performance. The ICS840-275 is packaged in a small 8-pin SOIC, making it ideal for use in systems with limited board space.

## FEATURES

- Two LVCMOS/LVTTL output, 15Ω output impedance
- Crystal oscillator interface designed for 25MHz, 18pF parallel resonant crystal
- Output frequency: 75MHz
- Random jitter: 3ps (typical)
- Deterministic jitter: 0.2ps (typical)
- 3.3V operating supply
- 0°C to 70°C ambient operating temperature
- Available in both standard (RoHS 5) and lead-free (RoHS 6) packages
- **Not Recommended for New Designs**

## BLOCK DIAGRAM

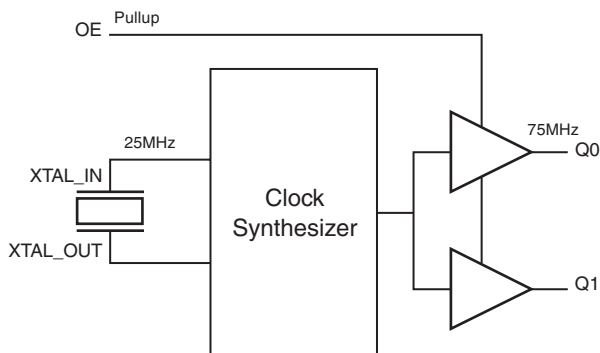

## PIN ASSIGNMENT

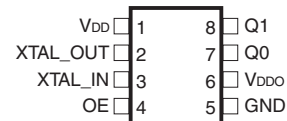

### ICS840-275

8-Lead SOIC

3.90mm x 4.92mm x 1.37mm body package

M Package

Top View

The Preliminary Information presented herein represents a product in pre-production. The noted characteristics are based on initial product characterization and/or qualification. Integrated Device Technology, Incorporated (IDT) reserves the right to change any circuitry or specifications without notice.

TABLE 1. PIN DESCRIPTIONS

Number	Name	Type		Description
1	V <sub>DD</sub>	Power		Power supply pin.
2, 3	XTAL_OUT, XTAL_IN	Input		Crystal oscillator interface. XTAL_IN is the input, XTAL_OUT is the output.
4	OE	Input	Pullup	Output enable pin. When HIGH, Qx outputs are enabled. When LOW, forces Qx outputs to HiZ state. LVCMOS/LVTTL interface levels.
5	GND	Power		Power supply ground.
6	V <sub>DDO</sub>	Power		Output supply pin.
7, 8	Q0, Q1	Output		Single-ended clock outputs. LVCMOS/LVTTL interface levels. 15Ω output impedance.

NOTE: *Pullup* refers to internal input resistors. See Table 2, Pin Characteristics, for typical values.

TABLE 2. PIN CHARACTERISTICS

Symbol	Parameter	Test Conditions	Minimum	Typical	Maximum	Units
C <sub>IN</sub>	Input Capacitance			4		pF
R <sub>PULLUP</sub>	Input Pullup Resistor			51		kΩ
R <sub>OUT</sub>	Output Impedance			15		Ω

TABLE 3. CONTROL FUNCTION TABLE

Control Inputs	Output
OE	Q0, Q1
0	Hi-Z
1	Active

**ABSOLUTE MAXIMUM RATINGS**

Supply Voltage, $V_{DD}$	4.6V
Inputs, $V_I$	-0.5V to $V_{DD} + 0.5 V$
Outputs, $V_O$	-0.5V to $V_{DDO} + 0.5V$
Package Thermal Impedance, $\theta_{JA}$	112.7°C/W (0 lfpm)
Storage Temperature, $T_{STG}$	-65°C to 150°C

NOTE: Stresses beyond those listed under Absolute Maximum Ratings may cause permanent damage to the device. These ratings are stress specifications only. Functional operation of product at these conditions or any conditions beyond those listed in the *DC Characteristics* or *AC Characteristics* is not implied. Exposure to absolute maximum rating conditions for extended periods may affect product reliability.

**TABLE 4A. POWER SUPPLY DC CHARACTERISTICS,  $V_{DD} = V_{DDO} = 3.3V \pm 0.3V$ ,  $T_A = -40^\circ C$  TO  $85^\circ C$**

Symbol	Parameter	Test Conditions	Minimum	Typical	Maximum	Units
$V_{DD}$	Power Supply Voltage		3.0	3.3	3.6	V
$V_{DDO}$	Output Supply Voltage		3.0	3.3	3.6	V
$I_{DD}$	Power Supply Current	OE = $V_{DD}$ (output enabled)			80	mA
$I_{DDO}$	Output Supply Current				20	mA

**TABLE 4B. LVCMOS/LVTTL DC CHARACTERISTICS,  $V_{DD} = V_{DDO} = 3.3V \pm 0.3V$ ,  $T_A = -40^\circ C$  TO  $85^\circ C$**

Symbol	Parameter	Test Conditions	Minimum	Typical	Maximum	Units
$V_{IH}$	Input High Voltage		2		$V_{DD} + 0.3$	V
$V_{IL}$	Input Low Voltage		-0.3		0.8	V
$I_{IH}$	Input High Current	$V_{DD} = V_{IN} = 3.6V$			5	$\mu A$
$I_{IL}$	Input Low Current	$V_{DD} = 3.6V, V_{IN} = 0V$	-150			$\mu A$
$V_{OH}$	Output High Voltage; NOTE 1		2.6			V
$V_{OL}$	Output Low Voltage; NOTE 1				0.5	V

NOTE 1: Outputs terminated with 50Ω to  $V_{DDO}/2$ . See Parameter Measurement Information Section, "3.3V Output Load Test Circuit".

**TABLE 5. CRYSTAL CHARACTERISTICS**

Parameter	Test Conditions	Minimum	Typical	Maximum	Units
Mode of Oscillation		Fundamental			
Frequency			25		MHz
Equivalent Series Resistance (ESR)				40	Ω
Shunt Capacitance				7	pF
Drive Level				300	$\mu W$

TABLE 6. AC CHARACTERISTICS,  $V_{DD} = V_{DDO} = 3.3V \pm 0.3V$ ,  $T_A = -40^{\circ}C$  TO  $85^{\circ}C$ 

Symbol	Parameter	Test Conditions	Minimum	Typical	Maximum	Units
$f_{OUT}$	Output Frequency			75		MHz
$t_{DJ}$	Deterministic Jitter; NOTE 1			0.2		ps
$t_{RJ}$	Random Jitter; NOTE 1			3		ps
$t_{RMS}$	RMS of Total Distribution ( $\sigma$ ); NOTE 1			3		ps
$t_{p-p}$	Peak-to-Peak Jitter; NOTE 1			28		ps
$t_{OSC}$	Oscillation Start Up Time	Time at minimum operating voltage to be 0 s			10	ms
$t_R / t_F$	Output Rise/Fall Time	20% to 80%		700		ps
odc	Output Duty Cycle			50		%

NOTE 1: Measured using Wavecrest SIA-3000.

## PARAMETER MEASUREMENT INFORMATION

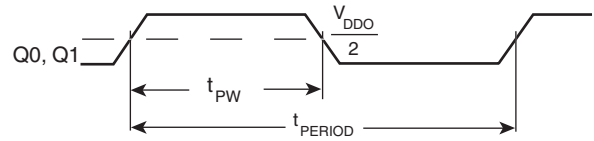
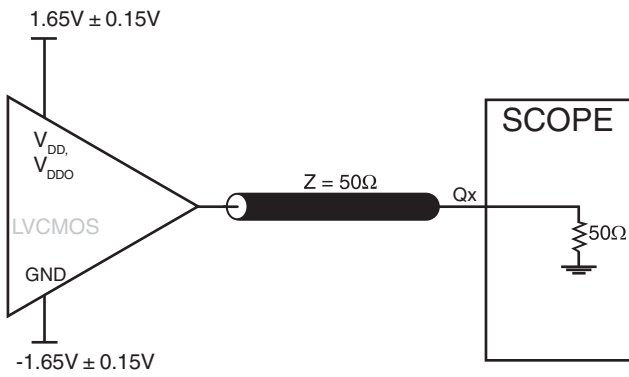

$$\text{odc} = \frac{t_{\text{PW}}}{t_{\text{PERIOD}}} \times 100\%$$

### 3.3V OUTPUT LOAD AC TEST CIRCUIT

### OUTPUT DUTY CYCLE/PULSE WIDTH/PERIOD

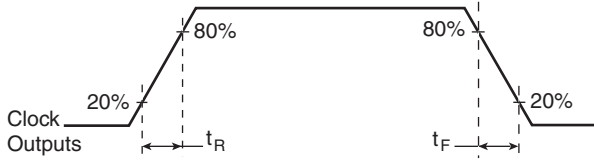

### OUTPUT RISE/FALL TIME

## APPLICATION INFORMATION

### RECOMMENDATIONS FOR UNUSED OUTPUT PINS

#### OUTPUTS:

##### LVCMOS OUTPUT:

All unused LVCMOS output can be left floating. We recommend that there is no trace attached.

### CRYSTAL INPUT INTERFACE

The ICS840-275 has been characterized with 18pF parallel resonant crystals. The capacitor values, C1 and C2, shown in *Figure 1* below were determined using a 25MHz, 18pF parallel

resonant crystal and were chosen to minimize the ppm error. The optimum C1 and C2 values can be slightly adjusted for different board layouts.

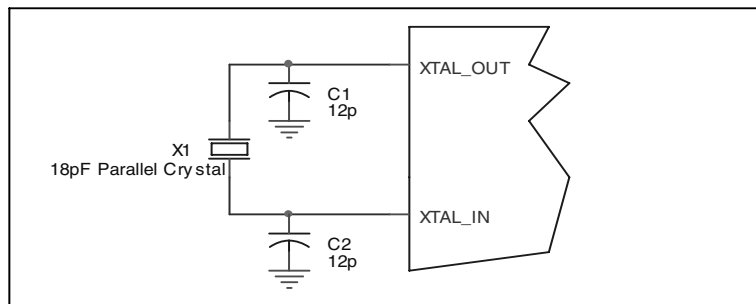

FIGURE 1. CRYSTAL INPUT INTERFACE

## RELIABILITY INFORMATION

TABLE 7.  $\theta_{JA}$  vs. AIR FLOW TABLE 8 LEAD SOIC

$\theta_{JA}$ by Velocity (Linear Feet per Minute)			
	0	200	500
Single-Layer PCB, JEDEC Standard Test Boards	153.3°C/W	128.5°C/W	115.5°C/W
Multi-Layer PCB, JEDEC Standard Test Boards	112.7°C/W	103.3°C/W	97.1°C/W

**NOTE:** Most modern PCB designs use multi-layered boards. The data in the second row pertains to most designs.

### TRANSISTOR COUNT

The transistor count for ICS840-275 is: 2423

## PACKAGE OUTLINE - M SUFFIX FOR 8 LEAD SOIC

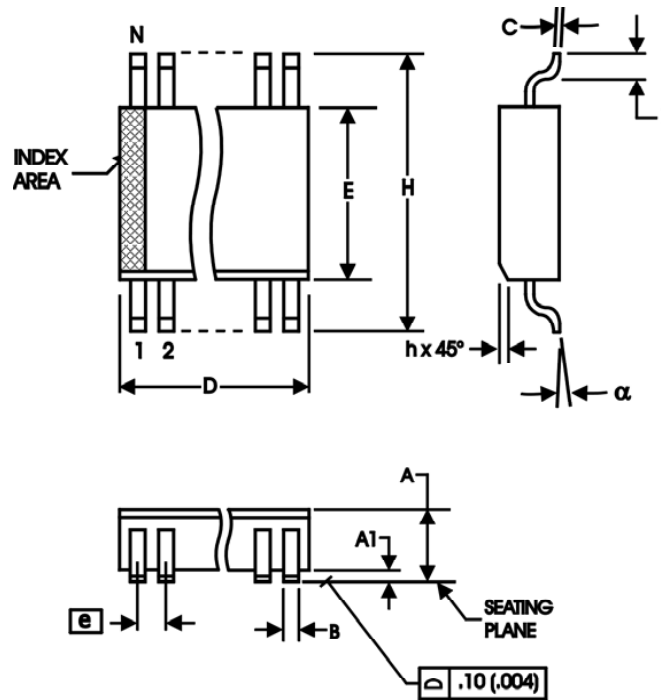

TABLE 8. PACKAGE DIMENSIONS

SYMBOL	Millimeters	
	MINIMUM	MAXIMUM
N	8	
A	1.35	1.75
A1	0.10	0.25
B	0.33	0.51
C	0.19	0.25
D	4.80	5.00
E	3.80	4.00
e	1.27 BASIC	
H	5.80	6.20
h	0.25	0.50
L	0.40	1.27
$\alpha$	0°	8°

Reference Document: JEDEC Publication 95, MS-012

TABLE 9. ORDERING INFORMATION

Part/Order Number	Marking	Package	Shipping Packaging	Temperature
ICS840AM-275	840AM275	8 lead SOIC	tube	0°C to 70°C
ICS840AM-275T	840AM275	8 lead SOIC	2500 tape & reel	0°C to 70°C
ICS840AM-275LF	840A275L	8 lead "Lead-Free" SOIC	tube	0°C to 70°C
ICS840AM-275LFT	840A275L	8 lead "Lead-Free" SOIC	2500 tape & reel	0°C to 70°C

NOTE: Parts that are ordered with an "LF" suffix to the part number are the Pb-Free configuration and are RoHS compliant.

While the information presented herein has been checked for both accuracy and reliability, Integrated Device Technology, Incorporated (IDT) assumes no responsibility for either its use or for infringement of any patents or other rights of third parties, which would result from its use. No other circuits, patents, or licenses are implied. This product is intended for use in normal commercial applications. Any other applications such as those requiring high reliability or other extraordinary environmental requirements are not recommended without additional processing by IDT. IDT reserves the right to change any circuitry or specifications without notice. IDT does not authorize or warrant any IDT product for use in life support devices or critical medical instruments.

Innovate with IDT and accelerate your future networks. Contact:

[www.IDT.com](http://www.IDT.com)

**For Sales**

800-345-7015  
408-284-8200  
Fax: 408-284-2775

**For Tech Support**

netcom@idt.com  
480-763-2056

---

**Corporate Headquarters**

Integrated Device Technology, Inc.  
6024 Silver Creek Valley Road  
San Jose, CA 95138  
United States  
800 345 7015  
+408 284 8200 (outside U.S.)

**Japan**

NIPPON IDT KK  
Sanbancho Tokyu Bld. 7F,  
8-1 Sanbancho  
Chiyoda-ku, Tokyo 102-0075  
+81 3 3221 9822  
+81 3 3221 9824 (fax)

**Asia**

Integrated Device Technology  
IDT (S) Pte. Ltd.  
1 Kallang Sector, #07-01/06  
Kolam Ayer Industrial Park  
Singapore 349276  
+65 6 744 3356  
+65 6 744 1764 (fax)

**Europe**

IDT Europe, Limited  
321 Kingston Road  
Leatherhead, Surrey  
KT22 7TU  
England  
+44 (0) 1372 363 339  
+44 (0) 1372 378851 (fax)