

15-OUTPUT DB1900Z LOW-POWER DERIVATIVE

9ZXL1530

Description

The 9ZXL1530 is a 15-output version of the Intel DB1900Z Differential Buffer utilizing Low-Power HCSL (LP-HCSL) outputs to reduce power consumption more than 50% from the original IDT9ZX21501. It is suitable for PCI-Express Gen1/2/3 or QPI/UPI applications, and uses a fixed external feedback to maintain low drift for demanding QPI/UPI applications.

Recommended Application

Buffer for Romley, Grantley and Purley Servers

Key Specifications

- Cycle-to-cycle jitter: < 50ps
- Output-to-output skew: <65ps
- Input-to-output delay: Fixed at 0 ps
- Input-to-output delay variation: <50ps
- Phase jitter: PCIe Gen3 < 1ps rms
- Phase jitter: QPI 9.6GB/s < 0.2ps rms

Features/Benefits

- Fixed feedback path; 0ps input-to-output delay
- 9 Selectable SMBus addresses; Multiple devices can share same SMBus segment
- Separate VDDIO for outputs; allows maximum power savings
- PLL or bypass mode; PLL can dejitter incoming clock
- Selectable PLL BW; minimizes jitter peaking in downstream PLL's
- Spread spectrum compatible; tracks spreading input clock for EMI reduction
- SMBus Interface; unused outputs can be disabled
- 100MHz & 133.33MHz PLL mode; Legacy QPI/UPI support
- Differential outputs are Low/Low in power down; Maximum power savings

Output Features

- 15 - LP-HCSL Differential Output Pairs

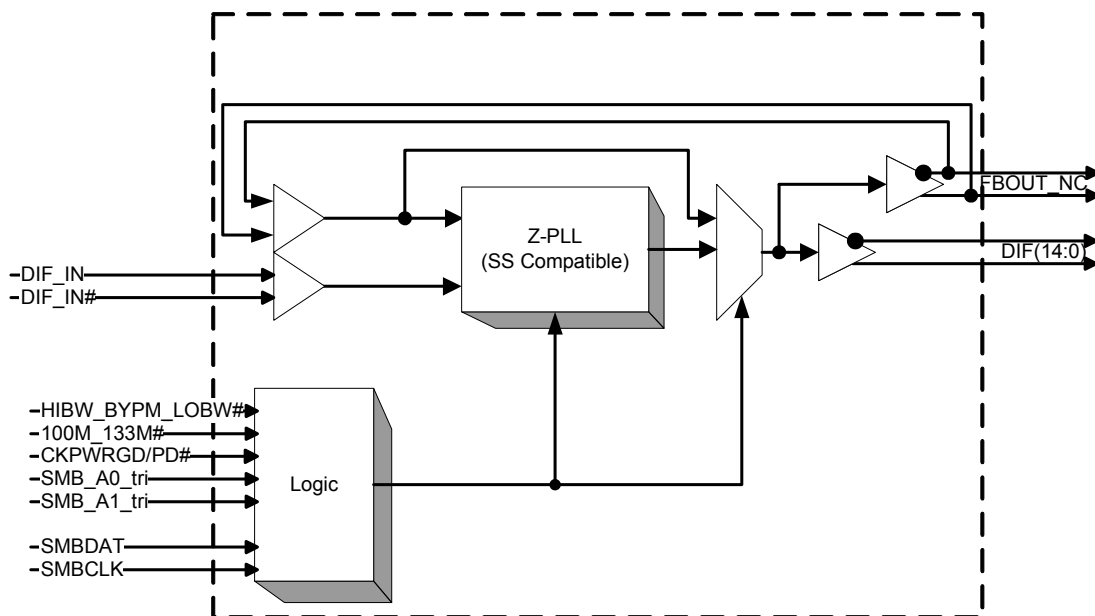
Block Diagram

Pin Configuration

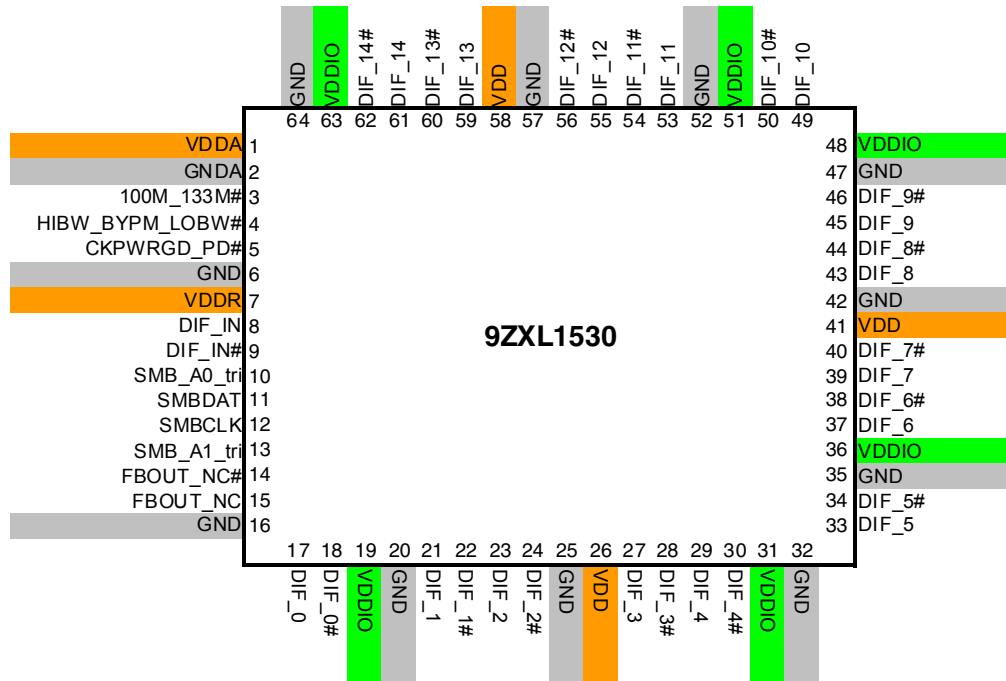

Note: Pins with ^ prefix have internal 120K pullup
Pins with v prefix have internal 120K pulldown

Power Management Table

Inputs		Control Bits	Outputs		PLL State
CKPWRGD_PD#	DIF_IN/ DIF_IN#	SMBus EN bit	DIF_x/ DIF_x#	FBOUT_NC/ FBOUT_NC#	
0	X	X	Low/Low	Low/Low	OFF
1	Running	0	Low/Low	Running	ON
		1	Running	Running	ON

Power Connections

Pin Number			Description
VDD	VDDIO	GND	
1		2	Analog PLL
7		6	Analog Input
26, 41, 58	19,31,36,48,51, ,63	16,20,25,32,3 5,42,47,52,57 ,64	DIF clocks

Functionality at Power-up (PLL mode)

100M_133M#	DIF_IN (MHz)	DIFx (MHz)
1	100.00	DIF_IN
0	133.33	DIF_IN

PLL Operating Mode

HiBW BypM LoBW#	Byte0, bit (7:6)
Low (PLL Low BW)	00
Mid (Bypass)	01
High (PLL High BW)	11

NOTE: PLL is off in Bypass mode

Tri-Level Input Thresholds

Level	Voltage
Low	<0.8V
Mid	1.2<Vin<1.8V
High	Vin > 2.2V

Pin Descriptions

PIN #	PIN NAME	TYPE	DESCRIPTION
1	VDDA	PWR	3.3V power for the PLL core.
2	GNDA	PWR	Ground pin for the PLL core.
3	100M_133M#	IN	3.3V Input to select operating frequency See Functionality Table for Definition
4	HIBW_BYPM_LOBW#	IN	Trilevel input to select High BW, Bypass or Low BW mode. See PLL Operating Mode Table for Details.
5	CKPWRGD_PD#	IN	Notifies device to sample latched inputs and start up on first high assertion, or exit Power Down Mode on subsequent assertions. Low enters Power Down Mode.
6	GND	PWR	Ground pin.
7	VDDR	PWR	3.3V power for differential input clock (receiver). This VDD should be treated as an analog power rail and filtered appropriately.
8	DIF_IN	IN	0.7 V Differential TRUE input
9	DIF_IN#	IN	0.7 V Differential Complementary Input
10	SMB_A0_tri	IN	SMBus address bit. This is a tri-level input that works in conjunction with the SMB_A1 to decode 1 of 9 SMBus Addresses.
11	SMBDAT	I/O	Data pin of SMBUS circuitry, 5V tolerant
12	SMBCLK	IN	Clock pin of SMBUS circuitry, 5V tolerant
13	SMB_A1_tri	IN	SMBus address bit. This is a tri-level input that works in conjunction with the SMB_A0 to decode 1 of 9 SMBus Addresses.
14	FBOUT_NC#	OUT	Complementary half of differential feedback output. This pin should NOT be connected to anything outside the chip. It exists to provide delay path matching to get 0 propagation delay.
15	FBOUT_NC	OUT	True half of differential feedback output. This pin should NOT be connected to anything outside the chip. It exists to provide delay path matching to get 0 propagation delay.
16	GND	PWR	Ground pin.
17	DIF_0	OUT	0.7V differential true clock output
18	DIF_0#	OUT	0.7V differential Complementary clock output
19	VDDIO	PWR	Power supply for differential outputs
20	GND	PWR	Ground pin.
21	DIF_1	OUT	0.7V differential true clock output
22	DIF_1#	OUT	0.7V differential Complementary clock output
23	DIF_2	OUT	0.7V differential true clock output
24	DIF_2#	OUT	0.7V differential Complementary clock output
25	GND	PWR	Ground pin.
26	VDD	PWR	Power supply, nominal 3.3V
27	DIF_3	OUT	0.7V differential true clock output
28	DIF_3#	OUT	0.7V differential Complementary clock output
29	DIF_4	OUT	0.7V differential true clock output
30	DIF_4#	OUT	0.7V differential Complementary clock output
31	VDDIO	PWR	Power supply for differential outputs
32	GND	PWR	Ground pin.

Pin Descriptions (cont.)

PIN #	PIN NAME	TYPE	DESCRIPTION
33	DIF_5	OUT	0.7V differential true clock output
34	DIF_5#	OUT	0.7V differential Complementary clock output
35	GND	PWR	Ground pin.
36	VDDIO	PWR	Power supply for differential outputs
37	DIF_6	OUT	0.7V differential true clock output
38	DIF_6#	OUT	0.7V differential Complementary clock output
39	DIF_7	OUT	0.7V differential true clock output
40	DIF_7#	OUT	0.7V differential Complementary clock output
41	VDD	PWR	Power supply, nominal 3.3V
42	GND	PWR	Ground pin.
43	DIF_8	OUT	0.7V differential true clock output
44	DIF_8#	OUT	0.7V differential Complementary clock output
45	DIF_9	OUT	0.7V differential true clock output
46	DIF_9#	OUT	0.7V differential Complementary clock output
47	GND	PWR	Ground pin.
48	VDDIO	PWR	Power supply for differential outputs
49	DIF_10	OUT	0.7V differential true clock output
50	DIF_10#	OUT	0.7V differential Complementary clock output
51	VDDIO	PWR	Power supply for differential outputs
52	GND	PWR	Ground pin.
53	DIF_11	OUT	0.7V differential true clock output
54	DIF_11#	OUT	0.7V differential Complementary clock output
55	DIF_12	OUT	0.7V differential true clock output
56	DIF_12#	OUT	0.7V differential Complementary clock output
57	GND	PWR	Ground pin.
58	VDD	PWR	Power supply, nominal 3.3V
59	DIF_13	OUT	0.7V differential true clock output
60	DIF_13#	OUT	0.7V differential Complementary clock output
61	DIF_14	OUT	0.7V differential true clock output
62	DIF_14#	OUT	0.7V differential Complementary clock output
63	VDDIO	PWR	Power supply for differential outputs
64	GND	PWR	Ground pin.

Absolute Maximum Ratings

Stresses above the ratings listed below can cause permanent damage to the 9ZXL1530. These ratings, which are standard values for IDT commercially rated parts, are stress ratings only. Functional operation of the device at these or any other conditions above those indicated in the operational sections of the specifications is not implied. Exposure to absolute maximum rating conditions for extended periods can affect product reliability. Electrical parameters are guaranteed only over the recommended operating temperature range.

PARAMETER	SYMBOL	CONDITIONS	MIN	TYP	MAX	UNITS	NOTES
3.3V Core Supply Voltage	VDDA, R				4.6	V	1,2
3.3V Logic Supply Voltage	VDD				4.6	V	1,2
I/O Supply Voltage	VDDIO				4.6	V	1,2
Input Low Voltage	V _{IL}		GND-0.5			V	1
Input High Voltage	V _{IH}	Except for SMBus interface			V _{DD} +0.5V	V	1
Input High Voltage	V _{IHSMB}	SMBus clock and data pins			5.5V	V	1
Storage Temperature	T _s		-65		150	°C	1
Junction Temperature	T _j				125	°C	1
Input ESD protection	ESD prot	Human Body Model	2000			V	1

¹Guaranteed by design and characterization, not 100% tested in production.

²Operation under these conditions is neither implied nor guaranteed.

Electrical Characteristics–DIF_IN Clock Input Parameters

TA = T_{COM}; Supply Voltage VDD/VDDA = 3.3 V +/-5%, VDDIO = 1.05 to 3.3V +/-5%. See Test Loads for Loading Conditions

PARAMETER	SYMBOL	CONDITIONS	MIN	TYP	MAX	UNITS	NOTES
Input Crossover Voltage - DIF_IN	V _{CROSS}	Cross Over Voltage	150		900	mV	1
Input Swing - DIF_IN	V _{SWING}	Differential value	300			mV	1
Input Slew Rate - DIF_IN	dv/dt	Measured differentially	0.4		8	V/ns	1,2
Input Leakage Current	I _{IN}	V _{IN} = V _{DD} , V _{IN} = GND	-5		5	uA	
Input Duty Cycle	d _{tin}	Measurement from differential waveform	45		55	%	1
Input Jitter - Cycle to Cycle	J _{DIFIN}	Differential Measurement	0		125	ps	1

¹Guaranteed by design and characterization, not 100% tested in production.

²Slew rate measured through +/-75mV window centered around differential zero

Electrical Characteristics–Input/Supply/Common Output Parameters

TA = T_{COM}; Supply Voltage VDD/VDDA = 3.3 V +/-5%, VDDIO = 1.05 to 3.3V +/-5%. See Test Loads for Loading Conditions

PARAMETER	SYMBOL	CONDITIONS	MIN	TYP	MAX	UNITS	NOTES
Ambient Operating Temperature	T _{COM}	Commercial range	0		70	°C	1
Input High Voltage	V _{IH}	Single-ended inputs, except SMBus, low threshold and tri-level inputs	2		V _{DD} + 0.3	V	1
Input Low Voltage	V _{IL}	Single-ended inputs, except SMBus, low threshold and tri-level inputs	GND - 0.3		0.8	V	1
Input Current	I _{IN}	Single-ended inputs, V _{IN} = GND, V _{IN} = VDD	-5		5	uA	1
	I _{INP}	Single-ended inputs V _{IN} = 0 V; Inputs with internal pull-up resistors V _{IN} = VDD; Inputs with internal pull-down resistors	-200		200	uA	1
Input Frequency	F _{ibyp}	V _{DD} = 3.3 V, Bypass mode	33		150	MHz	2
	F _{pII}	V _{DD} = 3.3 V, 100MHz PLL mode	90	100.00	110	MHz	2
	F _{pII}	V _{DD} = 3.3 V, 133.33MHz PLL mode	120	133.33	147	MHz	2
Pin Inductance	L _{pin}				7	nH	1
Capacitance	C _{IN}	Logic Inputs, except DIF_IN	1.5		5	pF	1
	C _{INDIF_IN}	DIF_IN differential clock inputs	1.5		2.7	pF	1,4
	C _{OUT}	Output pin capacitance			6	pF	1
Clk Stabilization	T _{STAB}	From V _{DD} Power-Up and after input clock stabilization or de-assertion of PD# to 1st clock			1	ms	1,2
Input SS Modulation Frequency	f _{MODIN}	Allowable Frequency (Triangular Modulation)	30		33	kHz	1
Tdrive_PD#	t _{DRVDP}	DIF output enable after PD# de-assertion			300	us	1,3
Tfall	t _F	Fall time of control inputs			5	ns	1,2
Trise	t _R	Rise time of control inputs			5	ns	1,2
SMBus Input Low Voltage	V _{ILSMB}				0.8	V	1
SMBus Input High Voltage	V _{IHSMB}		2.1		V _{DDSMB}	V	1
SMBus Output Low Voltage	V _{OLSMB}	@ I _{PULLUP}			0.4	V	1
SMBus Sink Current	I _{PULLUP}	@ V _{OL}	4			mA	1
Nominal Bus Voltage	V _{DDSMB}	3V to 5V +/- 10%	2.7		5.5	V	1
SCLK/SDATA Rise Time	t _{RSMB}	(Max VIL - 0.15) to (Min VIH + 0.15)			1000	ns	1
SCLK/SDATA Fall Time	t _{FSMB}	(Min VIH + 0.15) to (Max VIL - 0.15)			300	ns	1
SMBus Operating Frequency	f _{MINSMB}	Minimum SMBus operating frequency	100			kHz	1,5

¹Guaranteed by design and characterization, not 100% tested in production.

²Control input must be monotonic from 20% to 80% of input swing.

³Time from deassertion until outputs are >200 mV

⁴DIF_IN input

⁵The differential input clock must be running for the SMBus to be active

Electrical Characteristics–DIF 0.7V Low Power Differential Outputs

TA = T_{COM}; Supply Voltage VDD/VDDA = 3.3 V +/-5%, VDDIO = 1.05 to 3.3V +/-5%. See Test Loads for Loading Conditions

PARAMETER	SYMBOL	CONDITIONS	MIN	TYP	MAX	UNITS	NOTES
Slew rate	Trf	Scope averaging on	1	3	4	V/ns	1, 2, 3
Slew rate matching	ΔTrf	Slew rate matching.		7.6	20	%	1, 2, 4
Voltage High	VHigh	Statistical measurement on single-ended signal using oscilloscope math function. (Scope averaging on)	660	757	850	mV	1
Voltage Low	VLow		-150	16	150		1
Max Voltage	Vmax	Measurement on single ended signal using absolute value. (Scope averaging off)		857	1150	mV	1
Min Voltage	Vmin		-300	-36			1
Vswing	Vswing	Scope averaging off	300			mV	1, 2
Crossing Voltage (abs)	Vcross_abs	Scope averaging off	300	469	550	mV	1, 5
Crossing Voltage (var)	Δ-Vcross	Scope averaging off		14	140	mV	1, 6

¹Guaranteed by design and characterization, not 100% tested in production. C_L = 2pF with R_S = 27Ω for Z_o = 85Ω differential trace impedance.

² Measured from differential waveform

³ Slew rate is measured through the Vswing voltage range centered around differential 0V. This results in a +/-150mV window around differential 0V.

⁴ Matching applies to rising edge rate for Clock and falling edge rate for Clock#. It is measured using a +/-75mV window centered on the average cross point where Clock rising meets Clock# falling. The median cross point is used to calculate the voltage thresholds the oscilloscope is to use for the edge rate calculations.

⁵ Vcross is defined as voltage where Clock = Clock# measured on a component test board and only applies to the differential rising edge (i.e. Clock rising and Clock# falling).

⁶ The total variation of all Vcross measurements in any particular system. Note that this is a subset of Vcross_min/max (Vcross absolute) allowed. The intent is to limit Vcross induced modulation by setting Δ-Vcross to be smaller than Vcross absolute.

Electrical Characteristics–Current Consumption

TA = T_{COM}; Supply Voltage VDD/VDDA = 3.3 V +/-5%, VDDIO = 1.05 to 3.3V +/-5%. See Test Loads for Loading Conditions

PARAMETER	SYMBOL	CONDITIONS	MIN	TYP	MAX	UNITS	NOTES
Operating Supply Current	I _{DDVDD}	All outputs active @100MHz, C _L = 2pF;		23	40	mA	1
	I _{DDVDDA/R}	All outputs active @100MHz, C _L = 2pF;		15	20	mA	1
	I _{DDVDDIO}	All outputs active @100MHz, C _L = 2pF;		124	150	mA	1
Powerdown Current	I _{DDVDDPD}	All differential pairs low-low		2.2	4	mA	1
	I _{DDVDDA/RPD}	All differential pairs low-low		4.9	7	mA	1
	I _{DDVDDIOPD}	All differential pairs low-low		0.16	0.5	mA	1

¹Guaranteed by design and characterization, not 100% tested in production.

Electrical Characteristics—Skew and Differential Jitter Parameters

TA = T_{COM}; Supply Voltage VDD/VDDA = 3.3 V +/-5%, VDDIO = 1.05 to 3.3V +/-5%. See Test Loads for Loading Conditions

PARAMETER	SYMBOL	CONDITIONS	MIN	TYP	MAX	UNITS	NOTES
CLK_IN, DIF[x:0]	t _{SPO_PLL}	Input-to-Output Skew in PLL mode nominal value @ 25°C, 3.3V	-100	-44	100	ps	1,2,4,5,8
CLK_IN, DIF[x:0]	t _{PD_BYP}	Input-to-Output Skew in Bypass mode nominal value @ 25°C, 3.3V	2.5	3.6	4.5	ns	1,2,3,5,8
CLK_IN, DIF[x:0]	t _{DSPO_PLL}	Input-to-Output Skew Variation in PLL mode across voltage and temperature	-50	-2	50	ps	1,2,3,5,8
CLK_IN, DIF[x:0]	t _{DSPO_BYP}	Input-to-Output Skew Variation in Bypass mode across temperature for a given voltage	-250		250	ps	1,2,3,5,8
CLK_IN, DIF[x:0]	t _{DTE}	Random Differential Tracking error between two 9ZX devices in Hi BW Mode		3	5	ps (rms)	1,2,3,5,8
CLK_IN, DIF[x:0]	t _{DSSTE}	Random Differential Spread Spectrum Tracking error between two 9ZX devices in Hi BW Mode		15	75	ps	1,2,3,5,8
DIF[x:0]	t _{SKREW_ALL}	Output-to-Output Skew across all outputs (Common to Bypass and PLL mode)		45	65	ps	1,2,3,8
PLL Jitter Peaking	j _{peak-hibw}	LOBW#_BYPASS_HIBW = 1	0	1.75	2.5	dB	7,8
PLL Jitter Peaking	j _{peak-lobw}	LOBW#_BYPASS_HIBW = 0	0	0.75	2	dB	7,8
PLL Bandwidth	pll _{HIBW}	LOBW#_BYPASS_HIBW = 1	2	3.33	4	MHz	8,9
PLL Bandwidth	pll _{LOBW}	LOBW#_BYPASS_HIBW = 0	0.7	1.18	1.4	MHz	8,9
Duty Cycle	t _{DC}	Measured differentially, PLL Mode	45	50.4%	55	%	1
Duty Cycle Distortion	t _{DCD}	Measured differentially, Bypass Mode @100MHz	-2	0	2	%	1,10
Jitter, Cycle to cycle	t _{jyc-cyc}	PLL mode		24	50	ps	1,11
		Additive Jitter in Bypass Mode		0	50	ps	1,11

Notes for preceding table:

- ¹ Measured into fixed 2 pF load cap. Input to output skew is measured at the first output edge following the corresponding input.
- ² Measured from differential cross-point to differential cross-point. This parameter can be tuned with external feedback path, if present.
- ³ All Bypass Mode Input-to-Output specs refer to the timing between an input edge and the specific output edge created by it.
- ⁴ This parameter is deterministic for a given device
- ⁵ Measured with scope averaging on to find mean value.
- ⁶ t is the period of the input clock
- ⁷ Measured as maximum pass band gain. At frequencies within the loop BW, highest point of magnification is called PLL jitter peaking.
- ⁸ Guaranteed by design and characterization, not 100% tested in production.
- ⁹ Measured at 3 db down or half power point.
- ¹⁰ Duty cycle distortion is the difference in duty cycle between the output and the input clock when the device is operated in bypass mode.
- ¹¹ Measured from differential waveform

Electrical Characteristics–Phase Jitter Parameters

TA = T_{COM}; Supply Voltage VDD/VDDA = 3.3 V +/-5%, VDDIO = 1.05 to 3.3V +/-5%. See Test Loads for Loading Conditions

PARAMETER	SYMBOL	CONDITIONS	MIN	TYP	MAX	UNITS	Notes
Phase Jitter, PLL Mode	t _{jphPCleG1}	PCIe Gen 1		30.1	86	ps (p-p)	1,2,3
	t _{jphPCleG2}	PCIe Gen 2 Lo Band 10kHz < f < 1.5MHz		1.0	3	ps (rms)	1,2
		PCIe Gen 2 High Band 1.5MHz < f < Nyquist (50MHz)		1.7	3.1	ps (rms)	1,2
	t _{jphPCleG3}	PCIe Gen 3 (PLL BW of 2-4MHz, CDR = 10MHz)		0.38	1	ps (rms)	1,2,4
	t _{jphQPI_SMI}	QPI & SMI (100MHz or 133MHz, 4.8Gb/s, 6.4Gb/s 12UI)		0.18	0.5	ps (rms)	1,5
		QPI & SMI (100MHz, 8.0Gb/s, 12UI)		0.13	0.3	ps (rms)	1,5
		QPI & SMI (100MHz, 9.6Gb/s, 12UI)		0.10	0.2	ps (rms)	1,5
Additive Phase Jitter, Bypass mode	t _{jphPCleG1}	PCIe Gen 1		0.00	10	ps (p-p)	1,2,3
	t _{jphPCleG2}	PCIe Gen 2 Lo Band 10kHz < f < 1.5MHz		0.01	0.3	ps (rms)	1,2,6
		PCIe Gen 2 High Band 1.5MHz < f < Nyquist (50MHz)		0.00	0.7	ps (rms)	1,2,6
	t _{jphPCleG3}	PCIe Gen 3 (PLL BW of 2-4MHz, CDR = 10MHz)		0.00	0.3	ps (rms)	1,2,4,6
	t _{jphQPI_SMI}	QPI & SMI (100MHz or 133MHz, 4.8Gb/s, 6.4Gb/s 12UI)		0.12	0.3	ps (rms)	1,5,6
		QPI & SMI (100MHz, 8.0Gb/s, 12UI)		0.00	0.1	ps (rms)	1,5,6
		QPI & SMI (100MHz, 9.6Gb/s, 12UI)		0.00	0.1	ps (rms)	1,5,6

¹ Applies to all outputs.

² See <http://www.pcisig.com> for complete specs

³ Sample size of at least 100K cycles. This figures extrapolates to 108ps pk-pk @ 1M cycles for a BER of 1-12.

⁴ Subject to final ratification by PCI SIG.

⁵ Calculated from Intel-supplied Clock Jitter Tool v 1.6.4

⁶ For RMS figures, additive jitter is calculated by solving the following equation: (Additive jitter)² = (total jitter)² - (input jitter)²

Test Loads

Differential Output Terminations

DIF Zo (Ω)	Rs (Ω)
100	33
85	27

9ZXL Differential Test Loads

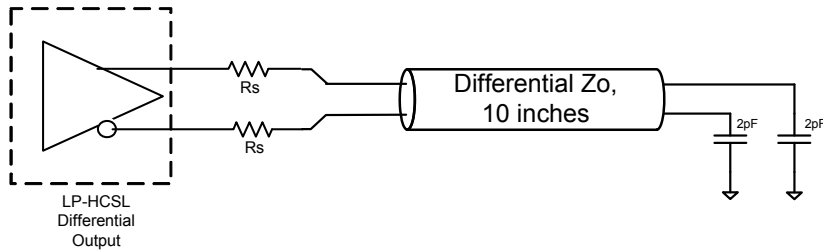

Clock Periods–Differential Outputs with Spread Spectrum Disabled

SSC OFF	Center Freq. MHz	Measurement Window							Units	Notes
		1 Clock	1us	0.1s	0.1s	0.1s	1us	1 Clock		
		-c2c jitter AbsPer Min	-SSC Short-Term Average Min	- ppm Long-Term Average Min	0 ppm Period Nominal	+ ppm Long-Term Average Max	+SSC Short-Term Average Max	+c2c jitter AbsPer Max		
DIF	100.00	9.94900		9.99900	10.00000	10.00100		10.05100	ns	1,2,3
	133.33	7.44925		7.49925	7.50000	7.50075		7.55075	ns	1,2,4

Clock Periods–Differential Outputs with Spread Spectrum Enabled

SSC ON	Center Freq. MHz	Measurement Window							Units	Notes
		1 Clock	1us	0.1s	0.1s	0.1s	1us	1 Clock		
		-c2c jitter AbsPer Min	-SSC Short-Term Average Min	- ppm Long-Term Average Min	0 ppm Period Nominal	+ ppm Long-Term Average Max	+SSC Short-Term Average Max	+c2c jitter AbsPer Max		
DIF	99.75	9.94906	9.99906	10.02406	10.02506	10.02607	10.05107	10.10107	ns	1,2,3
	133.00	7.44930	7.49930	7.51805	7.51880	7.51955	7.53830	7.58830	ns	1,2,4

Notes:

¹ Guaranteed by design and characterization, not 100% tested in production.

² All Long Term Accuracy specifications are guaranteed with the assumption that the input clock complies with CK420BQ/CK410B+ accuracy requirements (+/-100ppm). The 9ZXL1530 itself does not contribute to ppm error.

³ Driven by SRC output of main clock, 100 MHz PLL Mode or Bypass mode

⁴ Driven by CPU output of main clock, 133 MHz PLL Mode or Bypass mode

General SMBus Serial Interface Information

How to Write

- Controller (host) sends a start bit
- Controller (host) sends the write address
- IDT clock will **acknowledge**
- Controller (host) sends the beginning byte location = N
- IDT clock will **acknowledge**
- Controller (host) sends the byte count = X
- IDT clock will **acknowledge**
- Controller (host) starts sending Byte N through Byte N+X-1
- IDT clock will **acknowledge** each byte **one at a time**
- Controller (host) sends a Stop bit

Index Block Write Operation		
Controller (Host)		IDT (Slave/Receiver)
T	starT bit	
Slave Address		
WR	WRite	
Beginning Byte = N		ACK
		ACK
Data Byte Count = X		ACK
Beginning Byte N		ACK
O	X Byte	O
O		O
O		O
Byte N + X - 1		ACK
P	stoP bit	

How to Read

- Controller (host) will send a start bit
- Controller (host) sends the write address
- IDT clock will **acknowledge**
- Controller (host) sends the beginning byte location = N
- IDT clock will **acknowledge**
- Controller (host) will send a separate start bit
- Controller (host) sends the read address
- IDT clock will **acknowledge**
- IDT clock will send the data byte count = X
- IDT clock sends Byte N+X-1
- IDT clock sends **Byte 0 through Byte X (if X_(H) was written to Byte 8)**
- Controller (host) will need to acknowledge each byte
- Controller (host) will send a not acknowledge bit
- Controller (host) will send a stop bit

Index Block Read Operation		
Controller (Host)		IDT (Slave/Receiver)
T	starT bit	
Slave Address		
WR	WRite	
Beginning Byte = N		ACK
		ACK
RT	Repeat starT	
Slave Address		
RD	ReaD	
		ACK
ACK		Data Byte Count=X
		Beginning Byte N
ACK		O
O		O
O		O
O		
		Byte N + X - 1
N	Not acknowledge	
P	stoP bit	

9ZXL1530 SMBus Addressing

SMB_A(1:0)_tri	Address (Rd/Wrt bit = 0) (Hex)
00	D8
0M	DA
01	DE
M0	C2
MM	C4
M1	C6
10	CA
1M	CC
11	CE

SMBusTable: PLL Mode, and Frequency Select Register

Byte 0	Pin #	Name	Control Function	Type	0	1	Default
Bit 7	4	PLL Mode 1	PLL Operating Mode Rd back 1	R	See PLL Operating Mode		Latch
Bit 6	4	PLL Mode 0	PLL Operating Mode Rd back 0	R	Readback Table		Latch
Bit 5		Reserved					1
Bit 4	61/62	DIF_14_En	Output Enable	RW	Low/Low	Enable	1
Bit 3	59/60	DIF_13_En	Output Enable	RW	Low/Low	Enable	1
Bit 2		Reserved					0
Bit 1		Reserved					0
Bit 0	3	100M 133M#	Frequency Select Readback	R	133MHz	100MHz	Latch

SMBusTable: Output Control Register

Byte 1	Pin #	Name	Control Function	Type	0	1	Default
Bit 7	39/40	DIF_5_En	Output Enable	RW	Low/Low	Enable	1
Bit 6		Reserved					1
Bit 5	29/30	DIF_4_En	Output Enable	RW	Low/Low	Enable	1
Bit 4	29/30	DIF_3_En	Output Enable	RW			1
Bit 3	23/24	DIF_2_En	Output Enable	RW			1
Bit 2	21/22	DIF_1_En	Output Enable	RW			1
Bit 1	17/18	DIF_0_En	Output Enable	RW			1
Bit 0		Reserved					1

SMBusTable: Output Control Register

Byte 2	Pin #	Name	Control Function	Type	0	1	Default
Bit 7	55/56	DIF_12_En	Output Enable	RW	Low/Low	Enable	1
Bit 6	53/54	DIF_11_En	Output Enable	RW			1
Bit 5	49/50	DIF_10_En	Output Enable	RW			1
Bit 4		Reserved					1
Bit 3	45/46	DIF_9_En	Output Enable	RW			1
Bit 2	43/44	DIF_8_En	Output Enable	RW			1
Bit 1	39/40	DIF_7_En	Output Enable	RW			1
Bit 0	37/38	DIF_6_En	Output Enable	RW			1

SMBusTable: Reserved Register

Byte 3	Pin #	Name	Control Function	Type	0	1	Default
Bit 7		Reserved					0
Bit 6		Reserved					0
Bit 5		Reserved					0
Bit 4		Reserved					0
Bit 3		Reserved					0
Bit 2		Reserved					0
Bit 1		Reserved					0
Bit 0		Reserved					0

SMBusTable: Reserved Register

Byte 4	Pin #	Name	Control Function	Type	0	1	Default
Bit 7			Reserved				0
Bit 6			Reserved				0
Bit 5			Reserved				0
Bit 4			Reserved				0
Bit 3			Reserved				0
Bit 2			Reserved				0
Bit 1			Reserved				0
Bit 0			Reserved				0

SMBusTable: Vendor & Revision ID Register

Byte 5	Pin #	Name	Control Function	Type	0	1	Default
Bit 7	-	RID3	REVISION ID	R	B rev = 0001		X
Bit 6	-	RID2		R			X
Bit 5	-	RID1		R			X
Bit 4	-	RID0		R			X
Bit 3	-	VID3	VENDOR ID	R	-	-	0
Bit 2	-	VID2		R	-	-	0
Bit 1	-	VID1		R	-	-	0
Bit 0	-	VID0		R	-	-	1

SMBusTable: DEVICE ID

Byte 6	Pin #	Name	Control Function	Type	0	1	Default
Bit 7	-		Device ID 7 (MSB)	R	1530 is 153 decimal or 99 Hex		1
Bit 6	-		Device ID 6	R			X
Bit 5	-		Device ID 5	R			X
Bit 4	-		Device ID 4	R			X
Bit 3	-		Device ID 3	R			X
Bit 2	-		Device ID 2	R			0
Bit 1	-		Device ID 1	R			0
Bit 0	-		Device ID 0	R			1

SMBusTable: Byte Count Register

Byte 7	Pin #	Name	Control Function	Type	0	1	Default
Bit 7			Reserved				0
Bit 6			Reserved				0
Bit 5			Reserved				0
Bit 4	-	BC4	Writing to this register configures how many bytes will be read back.	RW	Default value is 8 hex, so 9 bytes (0 to 8) will be read back by default.		0
Bit 3	-	BC3		RW			1
Bit 2	-	BC2		RW			0
Bit 1	-	BC1		RW			0
Bit 0	-	BC0		RW			0

SMBusTable: Reserved Register

Byte 8	Pin #	Name	Control Function	Type	0	1	Default
Bit 7			Reserved				0
Bit 6			Reserved				0
Bit 5			Reserved				0
Bit 4			Reserved				0
Bit 3			Reserved				0
Bit 2			Reserved				0
Bit 1			Reserved				0
Bit 0			Reserved				0

DIF Reference Clock			
Common Recommendations for Differential Routing	Dimension or Value	Unit	Figure
L1 length, route as non-coupled 50ohm trace	0.5 max	inch	1
L2 length, route as non-coupled 50ohm trace	0.2 max	inch	1
L3 length, route as non-coupled 50ohm trace	0.2 max	inch	1
Rs (100 ohm differential traces)	33	ohm	1
Rs (85 ohm differential traces)	27	ohm	1

Down Device Differential Routing			
L4 length, route as coupled microstrip 100ohm differential trace	2 min to 16 max	inch	1
L4 length, route as coupled stripline 100ohm differential trace	1.8 min to 14.4 max	inch	1

Differential Routing to PCI Express Connector			
L4 length, route as coupled microstrip 100ohm differential trace	0.25 to 14 max	inch	2
L4 length, route as coupled stripline 100ohm differential trace	0.225 min to 12.6 max	inch	2

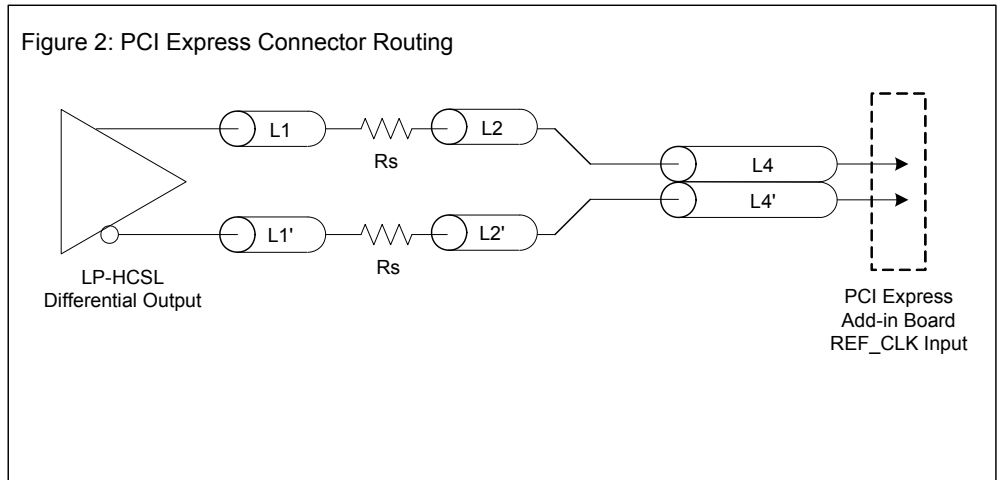
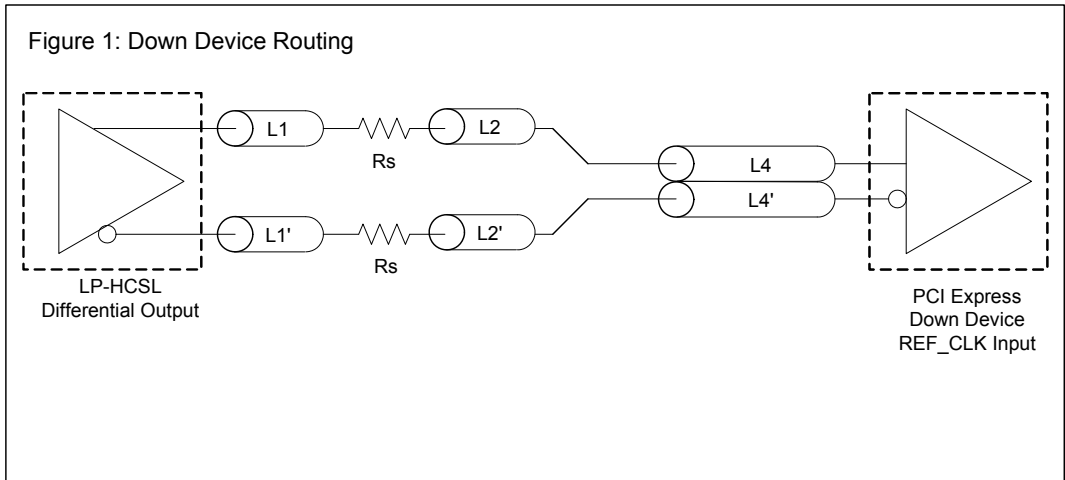

Cable Connected AC Coupled Application (Figure 3)		
Component	Value	Note
R5a, R5b	8.2K 5%	
R6a, R6b	1K 5%	
Cc	0.1 μ F	
Vcm	0.350 volts	

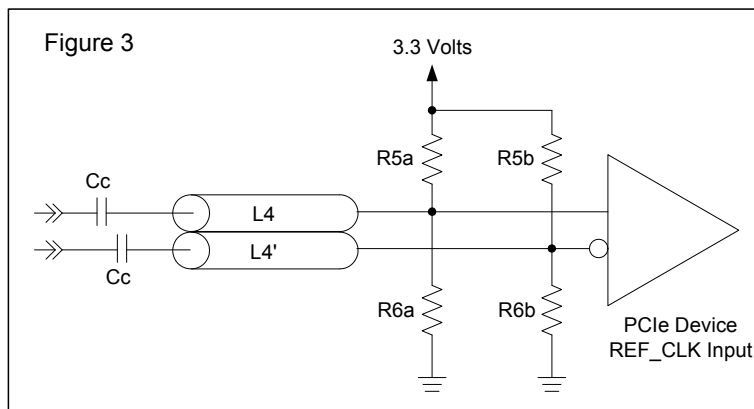

Marking Diagram



Notes:

1. "L" denotes RoHS compliant package.
2. "COO": country of origin.
3. YYWW is the last two digits of the year and week that the part was assembled.

Package Outline and Package Dimensions (64-pin MLF)

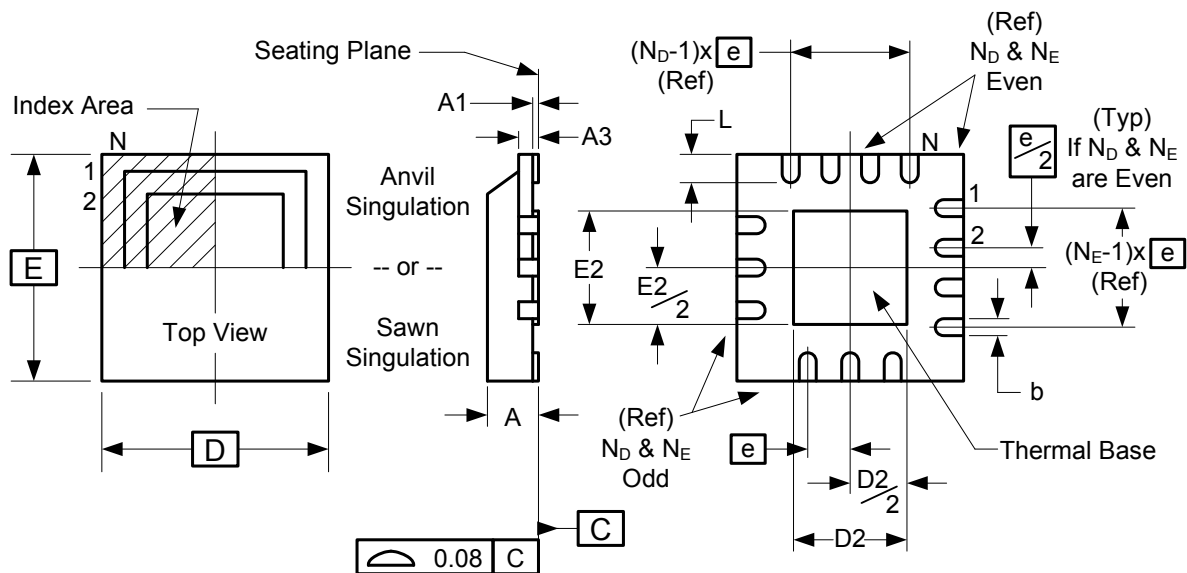

Symbol	Millimeters	
	Min	Max
A	0.8	1.0
A1	0	0.05
A3	0.25 Reference	
b	0.18	0.30
e	0.50 BASIC	
D x E BASIC	9.00 x 9.00	
D2 MIN./MAX.	6.00	6.25
E2 MIN./MAX.	6.00	6.25
L MIN./MAX.	0.30	0.50
N	64	
ND	16	
NE	16	

Ordering Information

Part / Order Number	Marking	Shipping Packaging	Package	Temperature
9ZXL1530BKLF	see page 16	Trays	64-pin MLF	0 to +70° C
9ZXL1530BKLFT		Tape and Reel	64-pin MLF	0 to +70° C

"LF" suffix to the part number are the Pb-Free configuration and are RoHS compliant.

"B" is the device revision designator (will not correlate with the datasheet revision).

While the information presented herein has been checked for both accuracy and reliability, Integrated Device Technology (IDT) assumes no responsibility for either its use or for the infringement of any patents or other rights of third parties, which would result from its use. No other circuits, patents, or licenses are implied. This product is intended for use in normal commercial applications. Any other applications such as those requiring extended temperature range, high reliability, or other extraordinary environmental requirements are not recommended without additional processing by IDT. IDT reserves the right to change any circuitry or specifications without notice. IDT does not authorize or warrant any IDT product for use in life support devices or critical medical instruments.

Revision History

Rev.	Issuer	Issue Date	Description	Page #
A	RDW	4/18/2011	<ol style="list-style-type: none"> 1. Update Electrical Tables with Characterization Data and corrected minor typos 2. Added Test Load information 3. Updated ordering information and also corrected table to show bulk parts ship in trays, not tubes. 4. Added mark information. 	5-10, 15,16
B	RDW	12/8/2011	<ol style="list-style-type: none"> 1. Updated tDSPO_BYP parameter by removing duplicate entry 2. Updated REV ID in byte 5 to indicate B rev 	8, 13
C	RDW	3/12/2012	<ol style="list-style-type: none"> 1. Corrected minor typos, Standardized output type references to LP-HCSL. 2. Added pin description for pin 37. 	1,4,9,10, 14
D	RDW	11/20/2015	<ol style="list-style-type: none"> 1. Updated QPI references to QPI/UPI 2. Updated DIF_IN table to match PCI SIG specification, no silicon change 	1,5

Innovate with IDT and accelerate your future networks. Contact:

www.IDT.com

For Sales

800-345-7015
408-284-8200
Fax: 408-284-2775

For Tech Support

www.idt.com/go/clockhelp
pclockhelp@idt.com

Corporate Headquarters

Integrated Device Technology, Inc.
www.idt.com



Mouser Electronics

Authorized Distributor

Click to View Pricing, Inventory, Delivery & Lifecycle Information:

[IDT \(Integrated Device Technology\):](#)

[9ZXL1530BKLFT](#) [9ZXL1530BKLF](#)