

6-Channel, 50mA Automotive LED Driver with Ultra-high Dimming Ratio and Phase Shift Control

ISL78171

ISL78171 is a 6-channel, 50mA, LED driver capable of very high dynamic range dimming. It offers an integrated boost converter, six high precision, adjustable current sinks and a SMBus/I²C interface for digital programmability and extensive diagnostics. These features provide the ISL78171 with the necessary capabilities to design compact, highly versatile LED backlight for a wide variety of ambient lighting conditions.

The integrated peak current mode PWM boost converter operates with a constant frequency and can boost an input voltage range of 4.5V - 26.5V to an output up to 40V and supply six strings of LEDs with up to 50mA each. A dynamic headroom control circuit detects and regulates the highest voltage string to improve efficiency in multistring configurations.

The six high precision adjustable current sinks offer typical current matching better than ±1% and a dimming ratio that is capable of exceeding 60,000:1. The dimming ratio can be adjusted with either or both the I²C/SMBus and an external PWM signal. They also feature an optional channel phase shift control which helps to reduce the input and output capacitance and ripple, to improve efficiency and to prevent audible noise.

The SMBus/I²C interface offers a wide range of programmability that includes the boost FET slew rate control, individual string enabling and converter switching frequency selections. It offers a wide range of protection features and diagnostics that cover all perceivable faults, enabling the system to self-diagnose the functioning of the backlight and react to such conditions as failed LEDs. The ISL78171 is offered in a compact and thermally efficient 20 Ld QFN package with an ambient temperature range of -40°C to +105°C.

Features

- 6 channels at 50mA maximum per channel
- Input voltage: 4.5V to 26.5V, output voltage: 40V max
- Bootstrap operation Input:3V to 21V output: 26.5V max
- PWM dimming with phase shift control
- SMBus/I²C controlled PWM or DC dimming
- Direct PWM dimming
- Internal PWM dimming mode linearity: 0.4% to 100%, dimming frequency <30kHz
- Direct PWM dimming duty cycle linearity: 0.007% to 100% at a dimming frequency of 200Hz
- Current matching ±0.7% typ
- 600kHz/800kHz/1.2MHz selectable switching frequency
- Dynamic headroom control
- Fault protection
 - String open/short circuit, OVP, OTP and optional output short circuit fault protection
- AEC-Q100 qualified

Applications

- Infotainment display LED backlighting
- LCD monitor LED backlighting
- Field sequential RGB LED backlighting

Related Literature

- [UG035](#), "ISL78171EVAL1Z Evaluation Board User Guide"

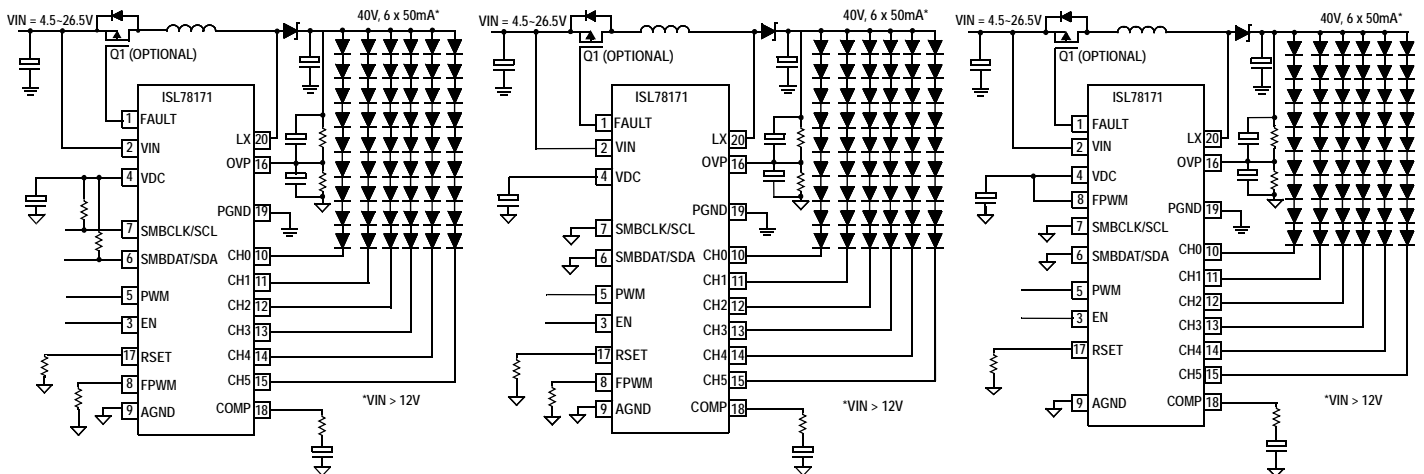

FIGURE 1A. SMBus/I²C CONTROLLED DIMMING AND ADJUSTABLE DIMMING FREQUENCY

FIGURE 1B. PWM DIMMING WITH PWM INPUT AND ADJUSTABLE DIMMING FREQUENCY

FIGURE 1C. DIRECT PWM DIMMING

FIGURE 1. ISL78171 TYPICAL APPLICATION DIAGRAMS

Table of Contents

Block Diagram	3
Ordering Information	3
Pin Configuration	4
Pin Descriptions	4
Thermal Information	5
Operating Conditions	5
Electrical Specifications	5
Typical Performance Curves	8
Theory of Operation	12
PWM Boost Converter	12
Enable	12
Current Matching and Current Accuracy	12
Dynamic Headroom Control	12
PWM Dimming Frequency Adjustment	14
Phase Shift Control	14
Switching Frequency	15
5V Low Dropout Regulator	15
IC Protection Features and Fault Management	15
SMBus/I ² C Communications	19
Write Byte	19
Read Byte	19
Slave Device Address	19
SMBus/I ² C Register Definitions	19
PWM Brightness Control Register (0x00)	21
Device Control Register (0x01)	21
Fault/Status Register (0x02)	22
Identification Register (0x03)	23
DC Brightness Control Register (0x07)	23
Configuration Register (0x08)	24
Output Channel Mask/Fault Readout Register (0x09)	24
Phase Shift Control Register (0x0A)	25
Secondary Boost Oscillator Register (0x7F)	25
Component Selection	25
Input Capacitor	25
Inductor	25
Output Capacitors	26
Output Ripple	26
Schottky Diode	26
Applications	26
High Current Applications	26
Low Voltage Operations	26
16-Bit Dimming	27
Field Sequential RGB LED Backlighting	27
Compensation	27
Revision History	28
About Intersil	28
Package Outline Drawing	29

Block Diagram

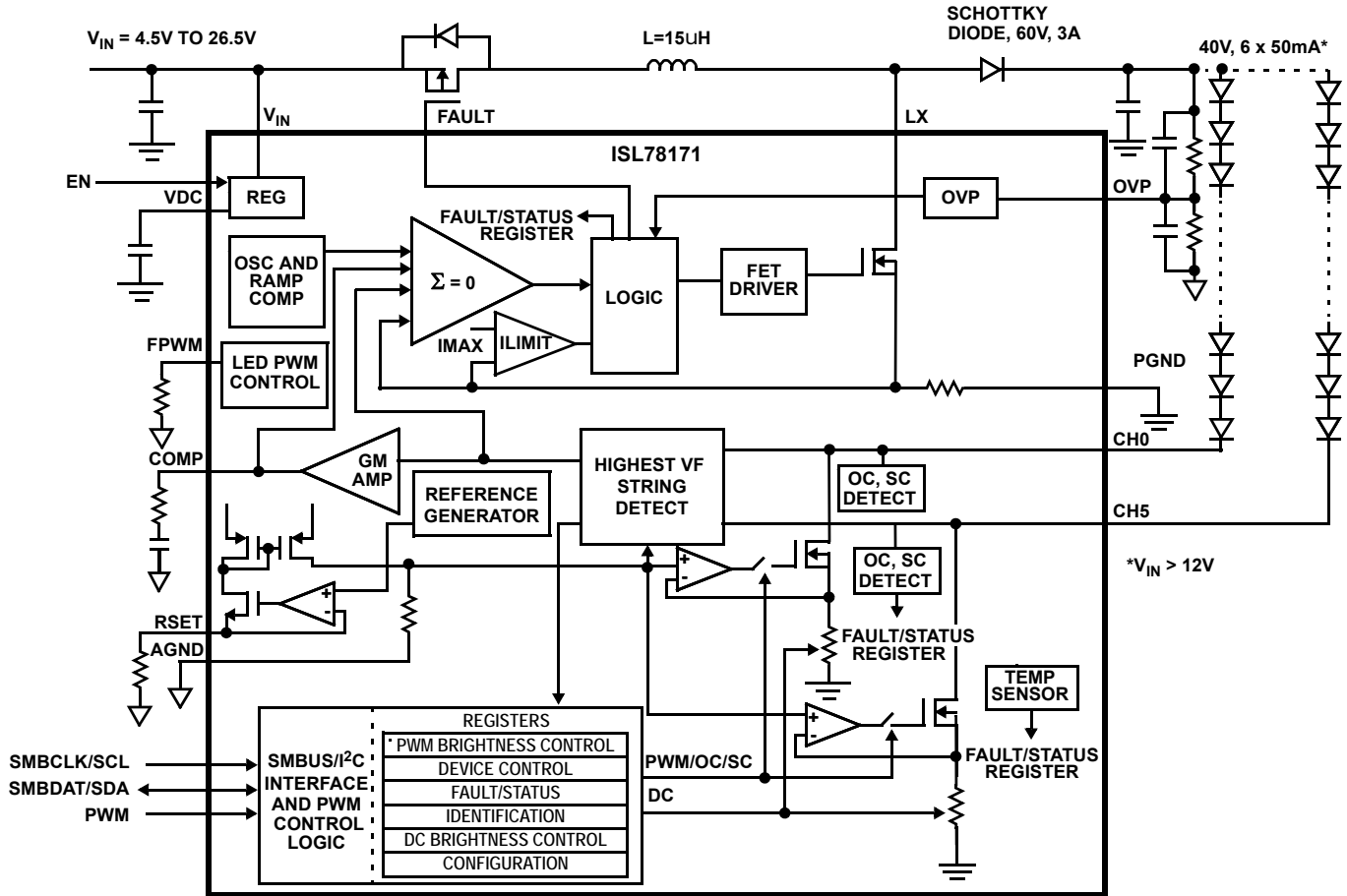

FIGURE 2. ISL78171 BLOCK DIAGRAM

Ordering Information

PART NUMBER (Notes 1, 2, 3)	PART MARKING	TEMP RANGE (°C)	PACKAGE (RoHS Compliant)	PKG. DWG. #
ISL78171ARZ	8171	-40 to +105	20 Ld 3x4 QFN	L20.3x4
ISL78171ARZ-EVALZ	Evaluation Board			

NOTES:

1. Add "-T*" suffix for tape and reel. Please refer to [TB347](#) for details on reel specifications.
2. These Intersil Pb-free plastic packaged products employ special Pb-free material sets, molding compounds/die attach materials, and 100% matte tin plate plus anneal (e3 termination finish, which is RoHS compliant and compatible with both SnPb and Pb-free soldering operations). Intersil Pb-free products are MSL classified at Pb-free peak reflow temperatures that meet or exceed the Pb-free requirements of IPC/JEDEC J STD-020.
3. For Moisture Sensitivity Level (MSL), please see product information page for [ISL78171](#). For more information on MSL please see techbrief [TB363](#).

ISL78171

Pin Configuration

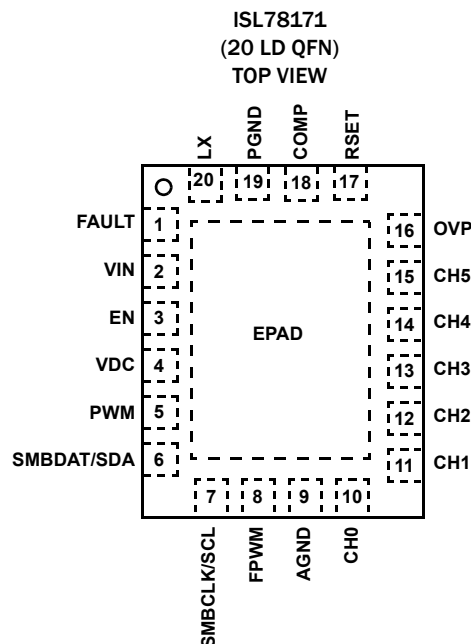

Pin Descriptions (I = Input, O = Output, S = Supply, X = Don't Care)

PIN NAME	PIN #	TYPE	DESCRIPTION
FAULT	1	O	This signal is the Fault disconnect switch gate control.
VIN	2	S	This is the input voltage for the device and LED power.
EN	3	I	This is the Enable input. The device needs 4ms for initial power-up enable. It will be disabled if it is not biased for longer than 30.5ms.
VDC	4	S	This is the internal LDO output for the purpose of filtering. Connect a 1uF X7R decoupling capacitor to ground.
PWM	5	I	This is the PWM brightness control pin or DPST control input. The pin has an internal pull down of 2M Ω so can be left floating when not used.
SMBDAT/SDA	6	I/O	This is the SMBus/I ² C serial data input and output. When pins 6 and 7 are grounded or in logic 0's for longer than 60ms, the drivers will be controlled by external PWM signal.
SMBCLK/SCL	7	I	This is the SMBus/I ² C serial clock input. When pins 6 and 7 are grounded or in logic 0's for longer than 60ms, the drivers will be controlled by external PWM signal.
FPWM	8	I	This pin sets the PWM dimming frequency, by connecting a resistor between this pin and ground. When FPWM is tied to VDC and SMBCLK/SMBDAT is tied to ground, the device will be in Direct PWM Dimming where the output follows the input frequency and duty cycle without any digitization.
AGND	9	S	This pin is the Analog Ground for precision circuits.
CH0, CH1 CH2, CH3 CH4, CH5	10, 11, 12, 13, 14, 15	I	These pins are the constant current sink and channel monitoring input for the LED string channels 0 through 5.
OVP	16	I	This is the Over voltage protection input.
RSET	17	I	A resistor connected between this pin and GND sets the max usable LED current, (see Equation 1 for calculating the I _{LED(peak)}). The value in the DC register 0x07 should be set to FF while setting the max LED current.
COMP	18	O	This is the Boost converter feedback compensation pin.
PGND	19	S	This pin is the Power ground pin.
LX	20	O	This pin is the Boost converter switch node.
EPAD			This pad is not an electrical connection but should be used to connect PGND and AGND. For example use top plane as PGND and bottom plane as AGND with vias on EPAD to allow heat dissipation and minimum noise coupling from PGND to AGND operation.

ISL78171

Absolute Maximum Ratings

VIN	-0.3V to 28V
EN	-0.3V to VIN - 0.3V
FAULT	VIN - 8.5V to VIN + 0.3V
VDC, COMP, RSET	-0.3V to 5.5V
SMBCLK/SCL, SMBDAT/SDA, FPWM, PWM	-0.3V to 5.5V
OVP	-0.3V to 2.8V
CH0-CH5, LX	-0.3V to 42.5V
PGND	-0.3V to +0.3V

Above voltage ratings are all with respect to AGND pin

ESD Rating

Human Body Model (Tested per AEC-Q100-002)	3.5kV
Machine Model (Tested per AEC-Q100-003)	200V
Charged Device Model (Tested per AEC-Q100-011)	1.5kV

Thermal Information

Thermal Resistance (Typical)	θ_{JA} (°C/W)	θ_{JC} (°C/W)
20 Ld QFN Package (Notes 4, 5, 7)	40	2.5
Thermal Characterization (Typical)	ψ_{JT} (°C/W)	
20 Ld QFN Package (Note 6)	1	
Maximum Continuous Junction Temperature	+125°C	
Storage Temperature	-65°C to +150°C	
Pb-free Reflow Profile	see TB493	

Operating Conditions

Temperature Range	-40°C to +105°C
VIN	4.5V to 26.5V
LX max	40.5V

CAUTION: Do not operate at or near the maximum ratings listed for extended periods of time. Exposure to such conditions may adversely impact product reliability and result in failures not covered by warranty.

NOTES:

- θ_{JA} is measured in free air with the component mounted on a high effective thermal conductivity test board with "direct attach" features. See Tech Brief [TB379](#).
- For θ_{JC} , the "case temp" location is the center of the exposed metal pad on the package underside.
- ψ_{JT} is the ψ junction-to-top thermal characterization parameter. If the package top temperature can be measured with this rating then the die junction temperature can be estimated more accurately than the θ_{JC} and θ_{JA} thermal resistance ratings.
- Refer to JESD51-7 high effective thermal conductivity board layout for proper via and plane designs.

Electrical Specifications $V_{IN} = 12V$, $EN = 5V$, $R_{SET} = 20.1k\Omega$, unless otherwise noted. Boldface limits apply across the operating temperature range, -40°C to +105°C.

PARAMETER	DESCRIPTION	TEST CONDITIONS	MIN (Note 8)	TYP	MAX (Note 8)	UNIT
GENERAL						
V_{IN} (Note 9)	Backlight Supply Voltage	≤10 LEDs per channel (type 3.2V (typ)/20mA)	4.5		26.5	V
I_{VIN_STBY}	V_{IN} Shutdown Current				5	μA
I_{VIN}	V_{IN} Active Current	$V_{IN} = 24V$, $EN = 5V$, $V_{DD} = 5V$. SDA, SCL are high		5		mA
V_{OUT}	Output Voltage	$4.5V < V_{IN} \leq 26.5V$, $f_{SW} = 600kHz$			40	V
		$8.55V < V_{IN} \leq 26.5V$, $f_{SW} = 1.2MHz$			40	V
V_{UVLO}	Undervoltage Lockout Threshold		2.1		2.6	V
V_{UVLO_HYS}	Undervoltage Lockout Hysteresis			200		mV
REGULATOR						
V_{DC}	LDO Output Voltage	$V_{IN} \geq 6V$	4.55	4.8	5	V
I_{VDC_STBY}	Standby Current	$EN = 0V$			5	μA
V_{LDO}	VDC LDO Load Regulation	$V_{IN} > 5.5V$, $I_{LDO} = 0$ to 20mA		20	200	mV
EN_{LOW}	EN Input Low Voltage				0.5	V
EN_{HI}	EN Input High Voltage		1.8			V
t_{ENLow}	EN Low Time To Shutdown			30.5		ms
BOOST						
SW_{ILimit}	Boost FET Current Limit		1.5	2.0	2.7	A
$r_{DS(ON)}$	Internal Boost Switch ON-resistance	$T_A = +25^\circ C$		235	300	mΩ
SS	Soft-start	100% LED Duty Cycle		7		ms

ISL78171

Electrical Specifications $V_{IN} = 12V$, $EN = 5V$, $R_{SET} = 20.1k\Omega$, unless otherwise noted. **Boldface limits apply across the operating temperature range, $-40^{\circ}C$ to $+105^{\circ}C$.** (Continued)

PARAMETER	DESCRIPTION	TEST CONDITIONS	MIN (Note 8)	TYP	MAX (Note 8)	UNIT
Eff_peak	Peak Efficiency	$V_{IN} = 12V$, 72 LEDs, 20mA each, $L = 10\mu H$ with DCR $101m\Omega$, $T_A = +25^{\circ}C$		92.9		%
		$V_{IN} = 12V$, 60 LEDs, 20mA each, $L = 10\mu H$ with DCR $101m\Omega$, $T_A = +25^{\circ}C$		90.8		%
$\Delta I_{OUT}/\Delta V_{IN}$	Line Regulation	$4.5V < V_{IN} \leq 26V$, $f_{SW} = 600kHz$		0.1		%
D_MAX	Boost Maximum Duty Cycle	$f_{SW} = 600kHz$	90			%
		$f_{SW} = 1.2MHz$	81			
D_MIN	Boost Minimum Duty Cycle	$f_{SW} = 600kHz$			9.5	%
		$f_{SW} = 1.2MHz$			17	
f_OSC_lo	Lx Frequency Low	Configuration Reg FSW bit=1	475	600	640	kHz
f_OSC_hi	Lx Frequency High	Configuration Reg FSW bit=0	0.97	1.2	1.31	MHz
I_LX_leakage	LX Pin Leakage Current	LX = 40V, EN = 0V			10	μA
LXstart_thres	LX Start-up Threshold		0.9		1.2	V
ILXStart-up	LX Start-up Current		1	3.5	5	mA
FAULT DETECTION						
V_SC	Short circuit Threshold Accuracy	Measured on the CHx pin	7.5	8.2		V
Temp_shtdwn	Temperature Shutdown Threshold			150		$^{\circ}C$
Temp_Hyst	Temperature Shutdown Hysteresis			23		$^{\circ}C$
V_OVPlo	Overvoltage threshold on OVP Pin		1.15	1.21	1.27	V
CURRENT SINKS						
I_MATCH	DC Channel-to-channel Current Matching	$R_{SET} = 20.1k\Omega$, Reg0x00 = 0xFF, ($I_{LED} = 20mA$)		± 0.7	± 1.5	%
I_ACC	Current Accuracy	$R_{SET} = 20.1k\Omega$, Reg0x00 = 0xFF, ($I_{LED} = 20mA$)	-2.2		+2.2	%
V_HEADROOM	Dominant Channel Current Sink Headroom at CHx Pin	$I_{LED} = 20mA$ $T_A = +25^{\circ}C$		500		mV
V_RSET	Voltage at RSET Pin	$R_{SET} = 20.1k\Omega$	1.17	1.22	1.25	V
I_LED(max)	Maximum LED Current per Channel	$V_{IN} = 12V$, $V_{OUT} = 40V$, $f_{SW} = 1.2MHz$, $T_A = +25^{\circ}C$		50		mA
PWM GENERATOR						
V_IL	PWM Input Low Voltage				0.8	V
V_IH	PWM Input High Voltage		1.5		5.0	V
F_PWMl	PWM Input Frequency Range		200		30,000	Hz
PWMACC	PWM Dimming Accuracy (Except Direct PWM Dimming)			8		bits
t_DIRECTPWM	Direct PWM Minimum On Time	Direct PWM Mode	250		350	ns
F_PWM	PWM Dimming Frequency Range		100		30,000	Hz
FAULT PIN						
I_FAULT	Fault Pull-down Current	$V_{IN} = 12V$	12	21	30	μA
V_FAULT	Fault Clamp Voltage with Respect to V_{IN}	$V_{IN} = 12$, $V_{IN} - V_{FAULT}$	6	7	8.3	V

ISL78171

Electrical Specifications $V_{IN} = 1.2V$, $EN = 5V$, $R_{SET} = 20.1k\Omega$, unless otherwise noted. **Boldface limits apply across the operating temperature range, $-40^{\circ}C$ to $+105^{\circ}C$.** (Continued)

PARAMETER	DESCRIPTION	TEST CONDITIONS	MIN (Note 8)	TYP	MAX (Note 8)	UNIT
SMBus/I²C INTERFACE						
V_{IL}	Data, Clock Input Low Voltage				0.8	V
V_{IH}	Data, Clock Input High Voltage		1.5		5.0	V
V_{OL}	SMBus/I ² C Data Line Logic Low Voltage	$I_{PULLUP} = 4mA$			0.17	V
I_{LEAK}	Input Leakage On SMBData/SMBClk	Measured at 4.8V	-10		10	μA
SMBus/I²C TIMING SPECIFICATIONS						
t_{EN-SMB/I^2C}	Minimum Time Between EN High and SMBus/I ² C Enabled	1 μF capacitor on VDC	2			ms
PWS	Pulse Width Suppression on SMBCLK/SMBDAT		0.15		0.45	μs
f_{SMB}	SMBus/I ² C Clock Frequency				400	kHz
t_{BUF}	Bus Free Time Between Stop and Start Condition		1.3			μs
$t_{HD:STA}$	Hold Time After (Repeated) START Condition. After this Period, the First Clock is Generated		0.6			μs
$t_{SU:STA}$	Repeated Start Condition Setup Time		0.6			μs
$t_{SU:STO}$	Stop Condition Setup Time		0.6			μs
$t_{HD:DAT}$	Data Hold Time		300			ns
$t_{SU:DAT}$	Data Setup Time		100			ns
t_{LOW}	Clock Low Period		1.3			μs
t_{HIGH}	Clock High Period		0.6			μs
t_F	Clock/Data Fall Time				300	ns
t_R	Clock/Data Rise Time				300	ns

NOTES:

- Compliance to datasheet limits is assured by one or more methods: production test, characterization and/or design.
- At maximum V_{IN} of 26.5V, minimum V_{OUT} is limited 28V.

Typical Performance Curves LED configuration: 6P10S

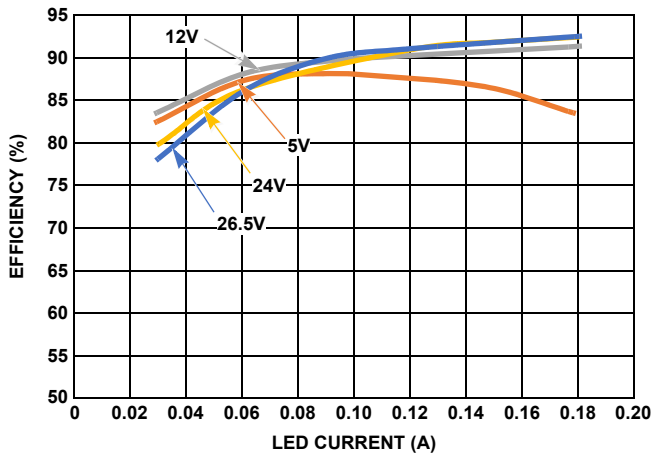

FIGURE 3. EFFICIENCY vs LED CURRENT AT LX
FREQUENCY = 600kHz AT -40°C vs V_{IN}

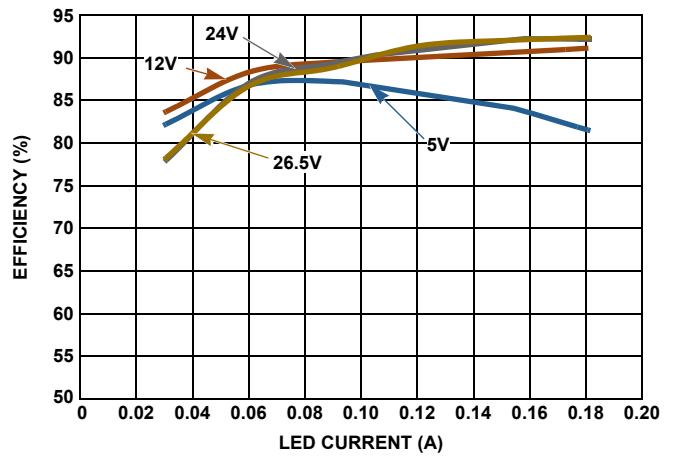

FIGURE 4. EFFICIENCY vs LED CURRENT AT LX
FREQUENCY = 600kHz AT +25°C vs V_{IN}

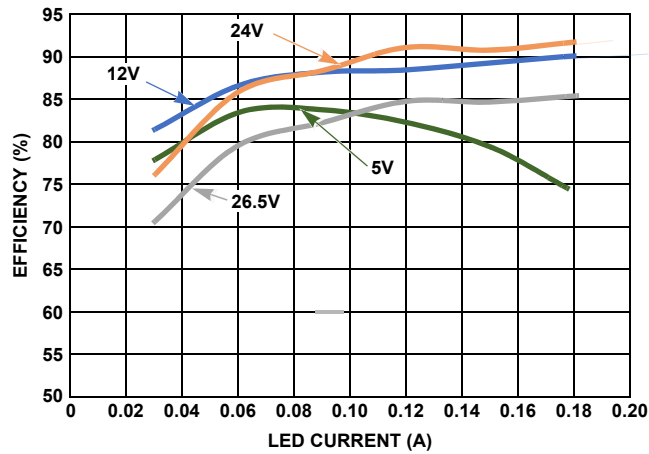

FIGURE 5. EFFICIENCY vs LED CURRENT AT LX
FREQUENCY = 600kHz AT +105°C vs V_{IN}

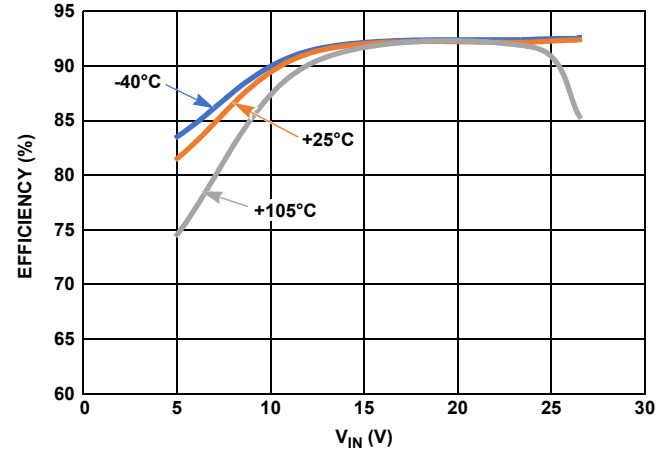

FIGURE 6. EFFICIENCY vs INPUT VOLTAGE AT LX
FREQUENCY = 600kHz vs V_{IN}

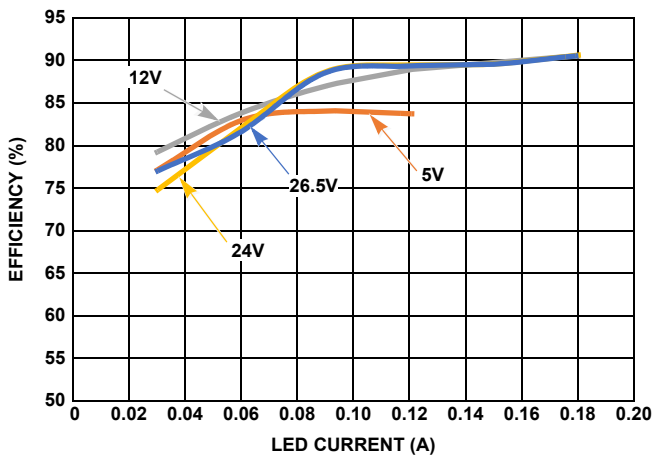

FIGURE 7. EFFICIENCY vs LED CURRENT AT LX
FREQUENCY = 1.2MHz AT -40°C vs V_{IN}

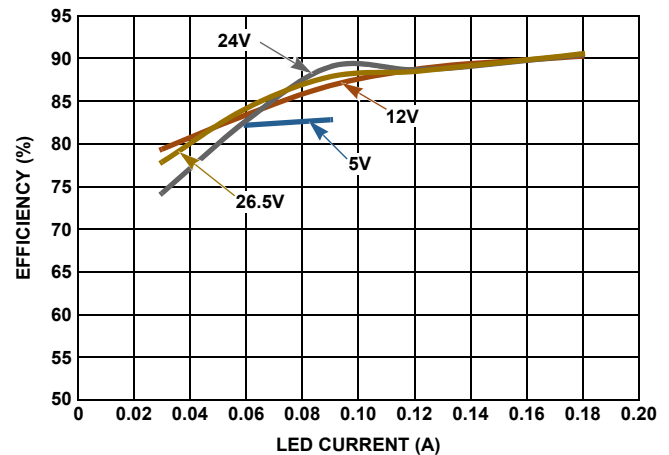

FIGURE 8. EFFICIENCY vs LED CURRENT AT LX
FREQUENCY = 1.2MHz AT +25°C vs V_{IN}

Typical Performance Curves LED configuration: 6P10S (Continued)

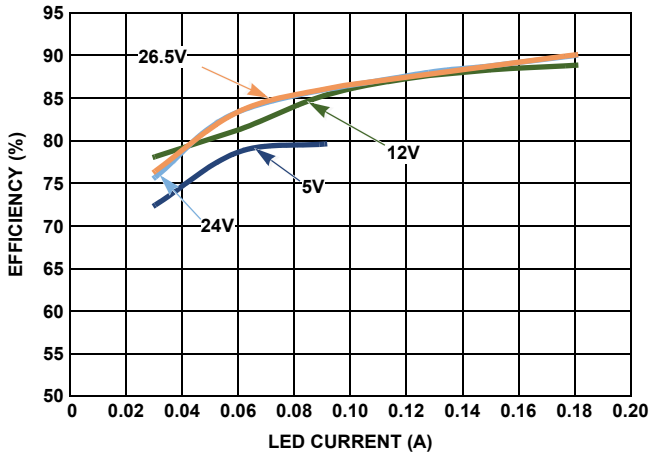

FIGURE 9. EFFICIENCY vs LED CURRENT AT LX FREQUENCY = 1.2MHz AT +105°C vs V_{IN}

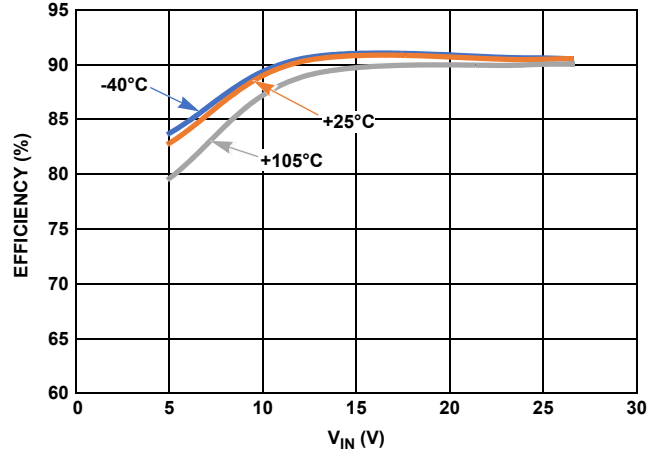

FIGURE 10. EFFICIENCY vs INPUT VOLTAGE AT LX FREQUENCY = 1.2MHz vs V_{IN}

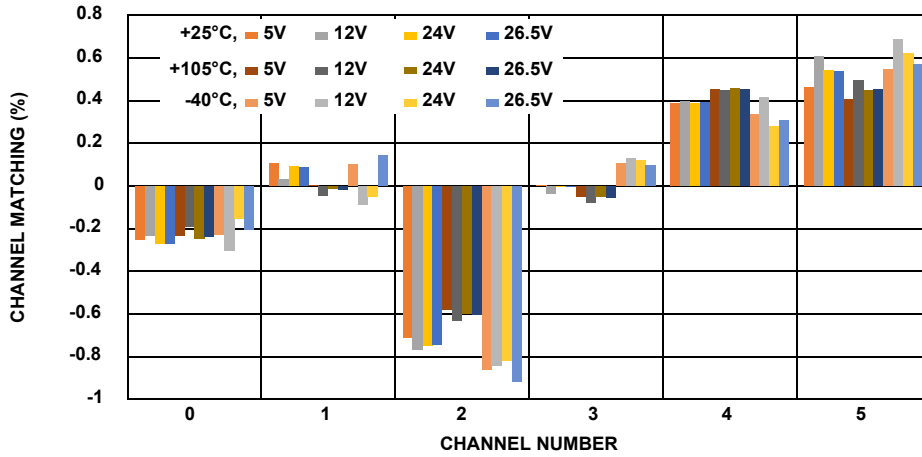

FIGURE 11. CHANNEL-TO-CHANNEL CURRENT MATCHING, 600kHz vs V_{IN}

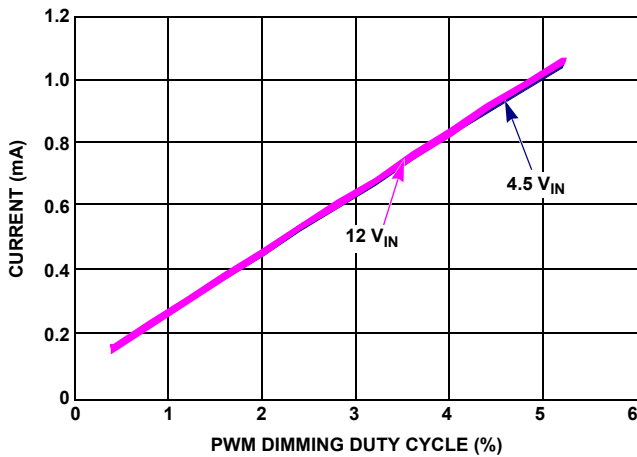

FIGURE 12. CURRENT LINEARITY vs LOW LEVEL PWM DIMMING DUTY CYCLE vs V_{IN}

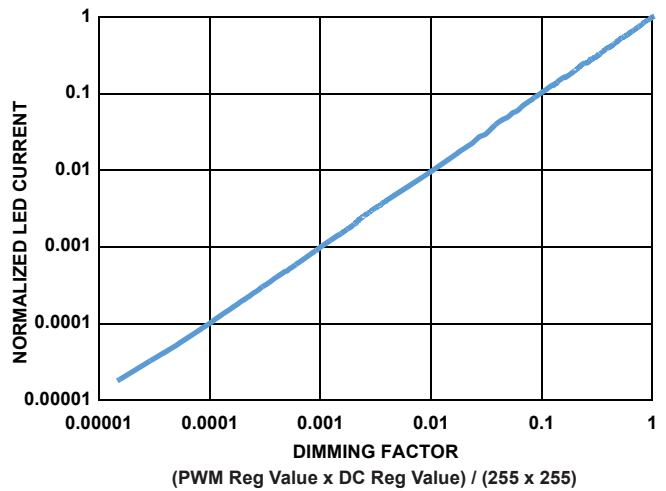

FIGURE 13. NORMALIZED LED CURRENT vs. DIMMING FACTOR, (MEASURED AT $I_{LED} = 20mA$)

Typical Performance Curves LED configuration: 6P10S (Continued)

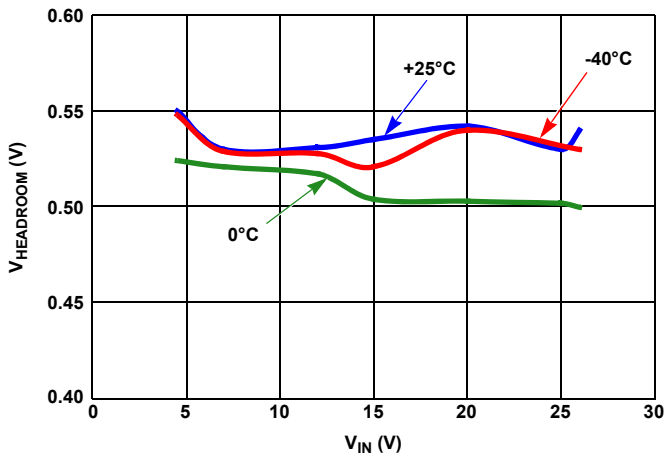

FIGURE 14. V_{HEADROOM} vs V_{IN} vs TEMPERATURE AT 20mA

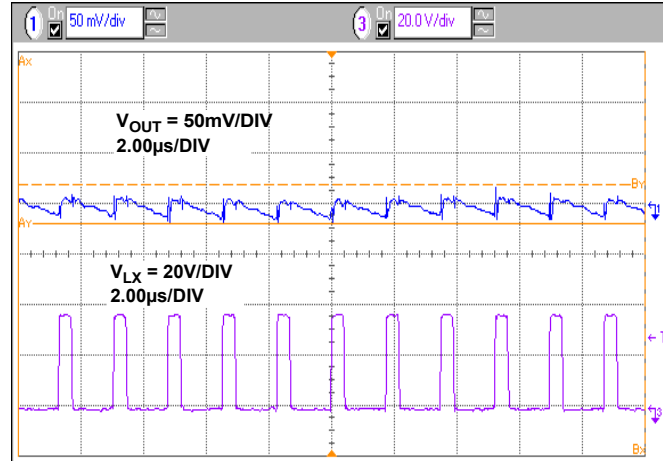

FIGURE 15. V_{OUT} RIPPLE VOLTAGE, V_{IN} = 12V, 6P12S AT 20mA/CHANNEL

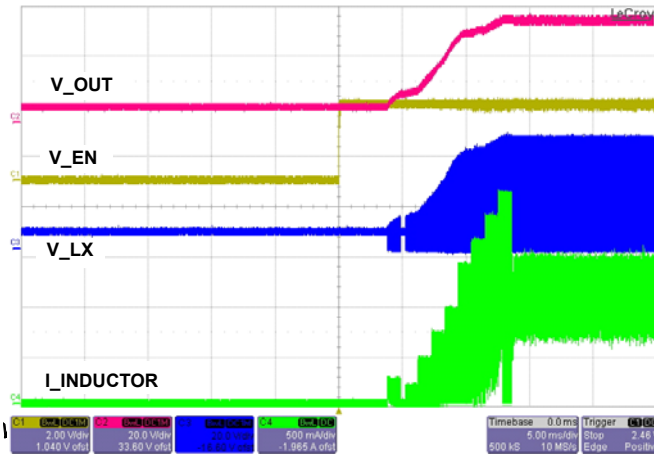

FIGURE 16. SOFT-START INDUCTOR CURRENT AT V_{IN} = 6V FOR 6P12S AT 20mA/CHANNEL

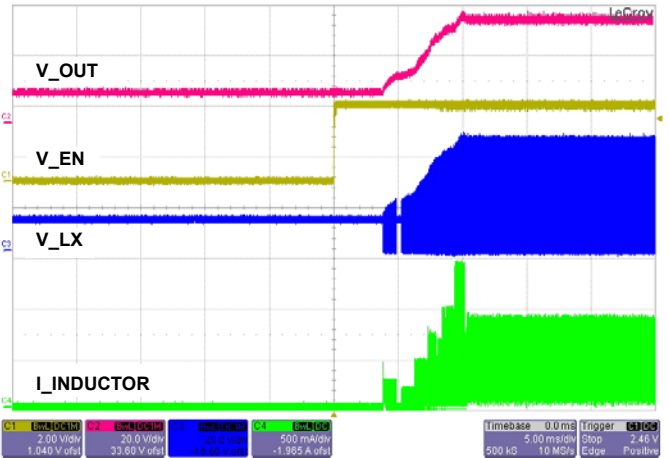

FIGURE 17. SOFT-START INDUCTOR CURRENT AT V_{IN} = 12V FOR 6P12S AT 20mA/CHANNEL

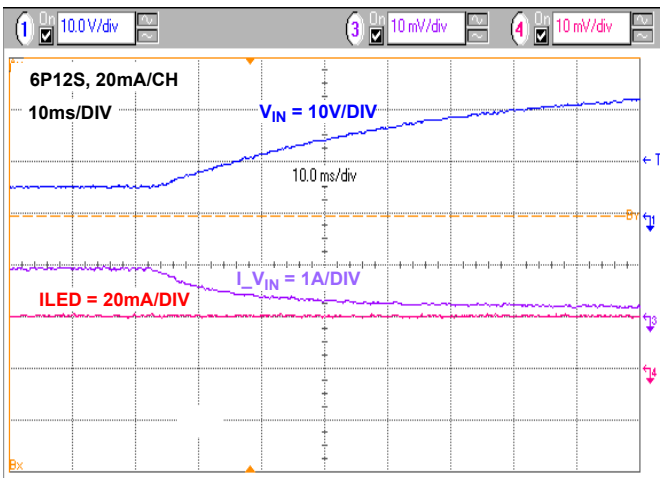

FIGURE 18. LINE REGULATION WITH V_{IN} CHANGE FROM 6V TO 26V, 6P12S AT 20mA/CHANNEL

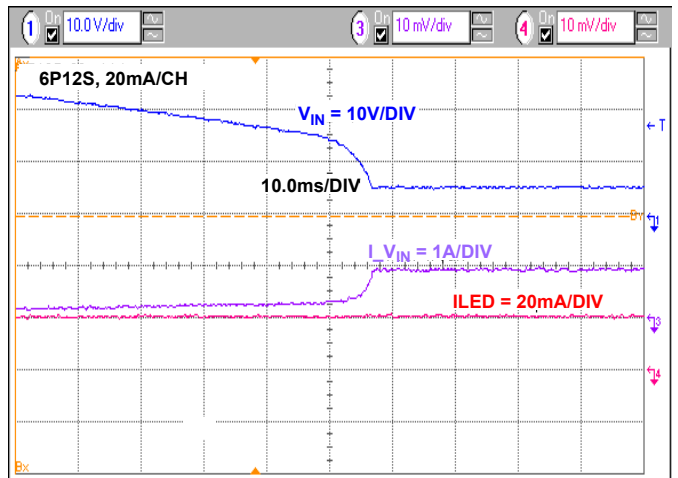

FIGURE 19. LINE REGULATION WITH V_{IN} CHANGE FROM 26V TO 6V FOR 6P12S AT 20mA/CHANNEL

Typical Performance Curves LED configuration: 6P10S (Continued)

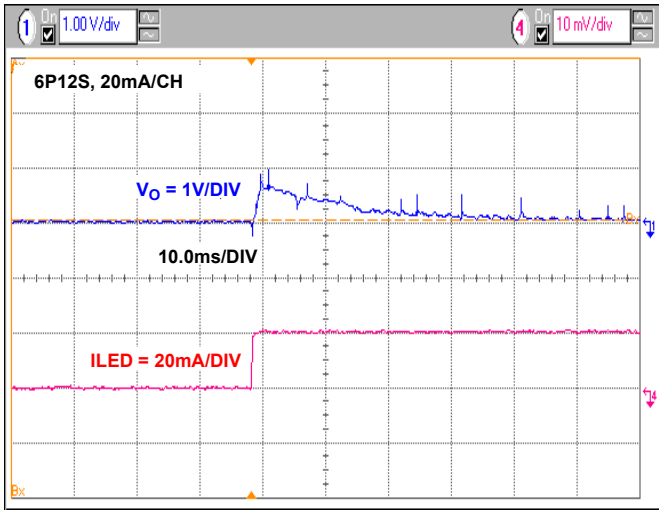

FIGURE 20. BOOST OUTPUT VOLTAGE WITH BRIGHTNESS CHANGE FROM 0% TO 100%, $V_{IN} = 12V$, 6P12S AT 20mA/CHANNEL

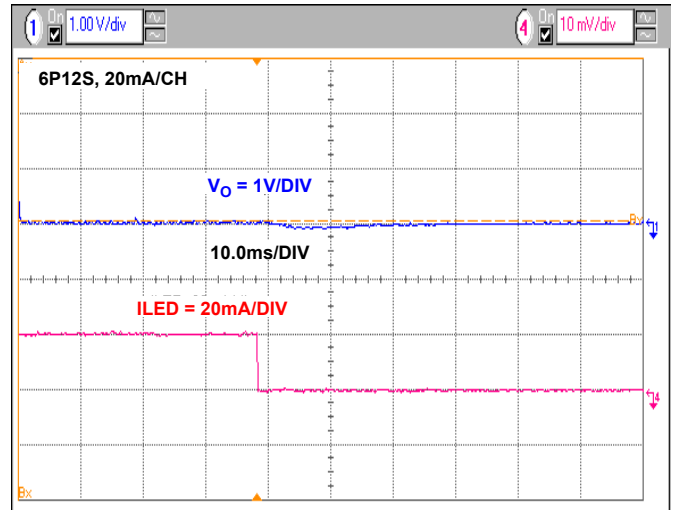

FIGURE 21. BOOST OUTPUT VOLTAGE WITH BRIGHTNESS CHANGE FROM 100% TO 0%, $V_{IN} = 12V$, 6P12S AT 20mA/CHANNEL

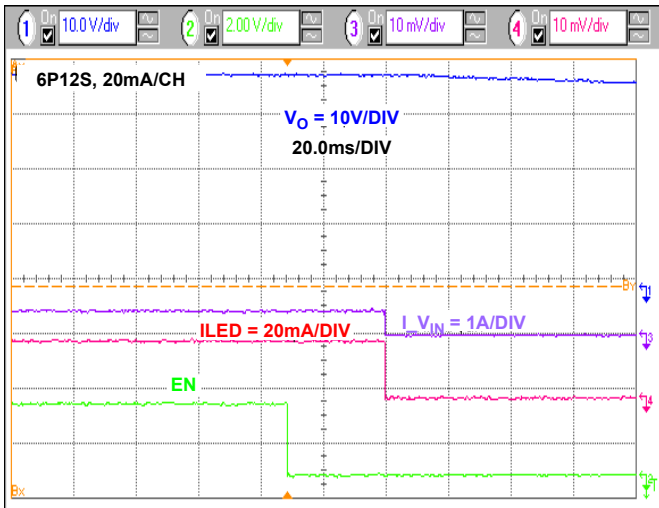

FIGURE 22. ISL78171 SHUTS DOWN AND STOPS SWITCHING ~30ms AFTER EN GOES LOW

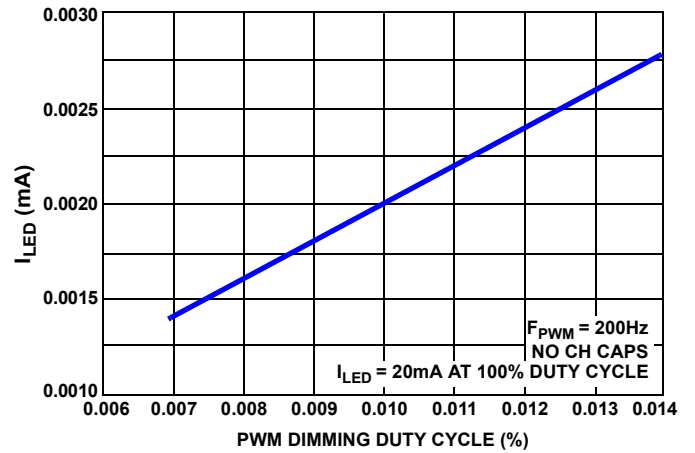

FIGURE 23. DIRECT PWM DIMMING LINEARITY AT VERY LOW DUTY CYCLE

Theory of Operation

PWM Boost Converter

The PWM boost converter operating in current mode produces the minimum voltage needed to enable up to six parallel LED strings having a combination of high and low forward voltage drop to run at the programmed current. The ISL78171 employs current mode control boost architecture that has a fast current sense loop and a slow voltage feedback loop. Such architecture achieves a fast transient response that is essential for notebook backlight applications in which drained batteries can be instantly changed to an AC/DC adapter without noticeable visual brightness change. The number of LEDs that can be driven by ISL78171 depends on the type of LED chosen in the application. The ISL78171 is capable of boosting up to 40V max and typically driving 12 LEDs in series for each of the 6 channels, enabling a total of 72 pieces of the 3.2V/20mA type of LEDs. At start-up, the LX pin injects a fixed current into the output capacitor. The device does not start unless the voltage at LX exceeds 1.2V. Also note that the VIN has to be 12V or greater to support an LED string current of 50mA per channel.

Enable

The EN pin is used to enable or disable the ISL78171 operation. It is a high voltage pin that can be tied directly to VIN up to 26.5V. If EN is pulled low for longer than 30ms, the device will shut down.

Current Matching and Current Accuracy

Each channel of the LED current is regulated by the current source circuit, as shown in [Figure 24](#).

The LED peak current is set by translating the RSET current to the output with a scaling factor of 410.5/RSET. The sink terminals of the current source MOSFETs are designed to run at 500mV to optimize the power loss versus accuracy requirements. The sources of errors of the channel-to-channel current matching come from the op amps offset, internal layout, reference and current source resistors. These parameters are optimized for current matching and absolute current accuracy. On the other hand, the absolute accuracy is additionally determined by the external RSET, and therefore, additional tolerance will be contributed by the current setting resistor. A 1% tolerance resistor is therefore recommended.

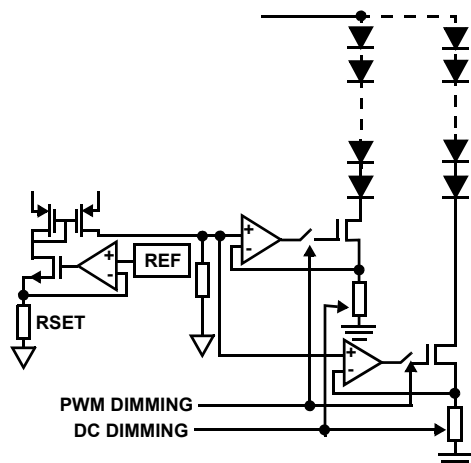

FIGURE 24. SIMPLIFIED CURRENT SOURCE CIRCUIT

Dynamic Headroom Control

The ISL78171 features a proprietary Dynamic Headroom Control circuit that detects the highest forward voltage string or effectively the lowest voltage from any of the CH0-CH5 pins to GND. When this lowest channel voltage is lower than the short circuit threshold, VSC, such voltage will be used as the feedback signal for the boost regulator. The boost makes the output to the correct level such that the lowest channel pin is at the target headroom voltage. Since all LED stacks are connected to the same output voltage, the other channel pins will have a higher voltage, but the regulated current source circuit on each channel will ensure that each channel has the same programmed current. The output voltage will regulate cycle-by-cycle and is always referenced to the highest forward voltage string in the architecture. If VSC function is enabled then the forward voltages across the LED string matching must be less than 7.5V.

MAXIMUM DC CURRENT SETTING

The initial brightness should be set by choosing an appropriate value for RSET. This should be chosen to fix the maximum possible LED current:

$$I_{LEDmax} = \frac{410.5}{R_{SET}} \quad (\text{EQ. 1})$$

Where ILEDmax is in mA and RSET in kΩ. Once RSET is fixed, the LED DC current can be adjusted by writing a value to the DC Brightness register 0x07 (BRTDC) as follows:

$$I_{LED} = 1.61 \times (\text{BRTDC} / R_{SET}) \quad (\text{EQ. 2})$$

BRTDC can be programmed from 0 to 255 in decimal and defaults to 255 (0xFF). If left at the default value, LED current will be fixed at ILEDmax. BRTDC can be adjusted dynamically on the fly during operation. BRTDC = 0 disconnects all channels.

For example, if the maximum required LED current (ILED(max)) is 20mA, rearranging [Equation 1](#) yields [Equation 3](#):

$$R_{SET} = 410.5 / 0.02 = 20.52 \text{ k}\Omega \quad (\text{EQ. 3})$$

If BRTDC is set to 200 then:

$$I_{LED} = 1.61 \cdot 200 / 20.52 = 15.69 \text{ mA} \quad (\text{EQ. 4})$$

PWM DIMMING CONTROL

The ISL78171 provides multiple PWM dimming methods, as described in the following. [Table 1](#) summarizes the dimming mode selection. Each of these methods results in PWM chopping of the current in the LEDs for all 6 channels to provide a lower average LED current. During the On periods, the LED current will be defined by the value of RSET and BRTDC, as described in [Equations 1](#) and [2](#). The source of the PWM signal can be described as follows:

- Internally Dimming Duty Cycle control:** The dimming duty cycle is controlled by a 256 step PWM brightness control register (BRT) which is programmed through the SMBus/I²C. The dimming frequency is set by the resistor connected to the FPWM pin.
- External Dimming Duty Cycle control:** The signal applied to the PWM input provides the dimming duty cycle information for the LED display. The dimming frequency is set by the resistor connected to the FPWM pin.

- 3. Display Power Saving Technology (DPST) mode:** The PWM dimming frequency is set by the resistor on FPWM pin & duty cycle is the product of the duty set by the 256 bit PWM brightness register (BRT) through PMBus/I²C and the duty cycle information from the external PWM input signal.
- 4. Direct PWM mode:** In this case the output duty cycle and dimming frequency follows the input PWM signal. This is purely an analog dimming method for use when the PMBus/I²C controls are not needed.

The default PWM dimming mode is in Display Power Saving Technology (DPST). In all of the methods, the average LED channel current is controlled by I_{LED} and the PWM duty cycle in percent, as shown in [Equation 5](#):

$$I_{LED(ave)} = I_{LED} \times PWM \quad (EQ. 5)$$

Method 1 (SMBus/I²C Controlled Dimming)

The average LED channel current is controlled by the internally generated PWM signal, as shown in [Equation 6](#):

$$I_{LED(ave)} = I_{LED} \times (BRT/255) \quad (EQ. 6)$$

Where BRT is the value programmed in the PWM brightness Register 0x00. BRT ranges from 0 to 255 in decimal and defaults to 255 (0xFF). BRT = 0 disconnects all channels.

Setting the Control Register 0x01 to 0x05 programs the device to use only the SMBus/I²C controlled PWM brightness control. Alternatively, the same operation can be obtained by setting Register 0x01 at its default value of 0x01 Display Power Saving Technology (DPST) and connecting the PWM input to VDC, so that the dimming level depends only on the BRT register.

The PWM dimming frequency is adjusted by a resistor at the FPWM pin.

Method 2 (PWM Controlled Dimming with Settable Dimming Frequency)

The average LED channel current is controlled by the duty cycle of external PWM signal, as shown in [Equation 7](#):

$$I_{LILED(ave)} = I_{LED} \times PWMI \quad (EQ. 7)$$

The PWM dimming frequency is adjusted by a resistor at the FPWM pin. The PWM input cannot be low for more than 30.5ms or else the driver will enter shutdown.

Setting the Control Register 0x01 to 0x03 programs the device to use the duty of the externally applied PWM signal for brightness control. Alternatively, the same operation can be obtained by leaving Register 0x01 at its default value of 0x01 Display Power Saving Technology (DPST), and not program Register BRT, so that it contains its default value of 0xFF.

Method 3 Display Power Saving Technology (DPST).

The average LED channel current can also be controlled by the product of the SMBus/I²C controlled PWM and the external PWM signals as:

$$I_{LED(ave)} = I_{LED} \times PWM_{DPST} \quad (EQ. 8)$$

Where:

$$PPWM_{DPST} = BRT/255 \times PWMI \quad (EQ. 9)$$

Therefore:

$$I_{LED(ave)} = I_{LED} \times BRT/255 \times PWMI \quad (EQ. 10)$$

Where BRT is the value held in PWM Register 0x00 (default setting 0xFF) controlled by SMBus/I²C and PWMI is the duty cycle of the incoming external PWM signal. In this way, the users can change the PWM current in ratio metric manner to achieve Display Power Saving Technology (DPST) compliant backlight dimming. To use the Display Power Saving Technology (DPST) mode, users need to set the control Register 0x01 to 0x01. The PWM dimming frequency is adjusted by a resistor at the FPWM pin.

For example, if the SMBus/I²C controlled PWM duty is 80% dimming at 200Hz (see [Equation 11](#)) and the external PWM duty cycle is 60% dimming at 1kHz, the resultant PWM duty cycle is 48% dimming at 200Hz.

In Display Power Saving Technology (DPST) mode, the ISL78171 features 8-bit dimming resolution. The product of the PWMI duty cycle, (digitized with 8-bit resolution) and of the BRT I²C register, results in a 16 bit value. The device calculates the dimming level by taking the 8 most significant bits of the 16 bit result.

Method 4 (Direct PWM Mode)

Direct PWM Dimming mode is selected when F_{PWM} is tied to V_{DC} and SMBCLK/SMBDAT are grounded. The current of the six LED channels will follow the External PWM signal's frequency and duty cycle. The minimum duty cycle can be as low as 0.007% at 200Hz (or equivalent pulse width of 350ns). This ultra low duty cycle dimming performance can be achieved if no channel capacitor is present. Also, in Direct PWM Dimming mode the Phase Shift function will be disabled.

TABLE 1. DIMMING MODE SELECTION

DIMMING METHOD SELECTION	SMBCLK/ SCL PIN SIGNAL	SMBDAT/ SDA PIN SIGNAL	FPWM PIN	0x01 REGISTER
Method 1 (SMBUS/I ² C controlled dimming, PWM Reg for Duty and FPWM for Frequency)	SMBUS/ I ² C clock	SMBUS/ I ² C data	Resistor to ground	Set to 0x05, or set to 0x01 and connect PWM to VDC
Method 2 (PWMI for Duty & FPWM for Frequency)	SMBUS/ I ² C clock	SMBUS/ I ² C data	Resistor to ground	Set to 0x03, or set to 0x01 and not program register 0x00
Method 2 (PWMI for Duty & FPWM for Frequency)	Grounded	Grounded	Resistor to ground	N/A
Method 3 Display Power Saving Technology (DPST), Product of PWMI & PWM Reg for Duty and FPWM for Frequency)	SMBUS/ I ² C clock	SMBUS/ I ² C data	Resistor to ground	Set to 0x01
Method 4 (Direct PWM dimming, PWMI for Duty and Frequency)	Grounded	Grounded	Tie to VDC	N/A

PWM Dimming Frequency Adjustment

For dimming methods 1-3, the PWM dimming frequency is set by an external resistor at the FPWM pin and can be calculated by equation 11:

$$F_{\text{PWM}} = \frac{6.66 \times 10^7}{R_{\text{FPWM}}} \quad (\text{EQ. 11})$$

Where F_{PWM} is the PWM dimming frequency in Hz and R_{FPWM} is the setting resistor in Ω .

The PWM dimming frequency range is between 200Hz to 30kHz and the duty cycle range is from 0.4% to 100%.

Phase Shift Control

For dimming methods 1-3, the ISL78171 is capable of delaying the phase of each current source to minimize load transients. By default, phase shifting is disabled as shown in Figure 25 where the channels PWM currents are switching at the same time.

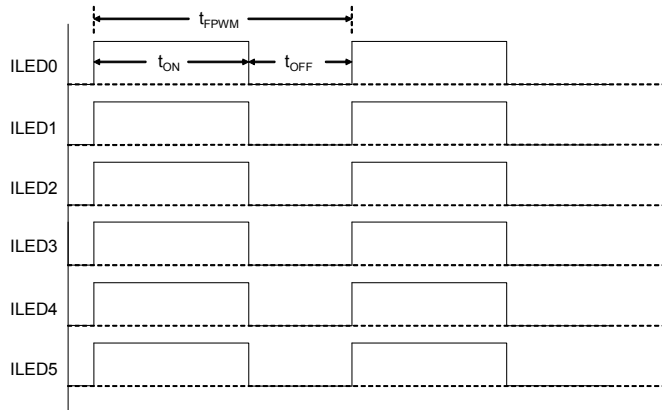

FIGURE 25. NO DELAY (DEFAULT PHASE SHIFT DISABLED)

When EqualPhase = 1 (register 0x0A, bit 7), the phase shift evenly spreads the channels switching across the PWM cycle, depending on how many channels are enabled, as shown in Figures 26 and 27. Equal phase means there are fixed delays between channels and such delay can be calculated as Equation 12 in Figures 26 and 27.

$$t_{D1} = \frac{t_{\text{FPWM}}}{255} \times \left(\frac{255}{N} \right) \quad (\text{EQ. 12})$$

Equation 13 shows the phase delay between the last channel of the current duty cycle and the first channel of the next duty cycle in Figures 26 and 27.

$$t_{D2} = \frac{t_{\text{FPWM}}}{255} \times \left(255 - (N - 1) \left(\frac{255}{N} \right) \right) \quad (\text{EQ. 13})$$

Where $(255/N)$ is rounded down to the nearest integer. For example, if $N = 6$, $(255/N) = 42$, that leads to:

$$t_{D1} = t_{\text{FPWM}} \times 42/255$$

$$t_{D2} = t_{\text{FPWM}} \times 45/255$$

Where t_{FPWM} is the sum of t_{ON} and t_{OFF} . N is the number of LED channels. The ISL78171 will detect the number of operating channels automatically.

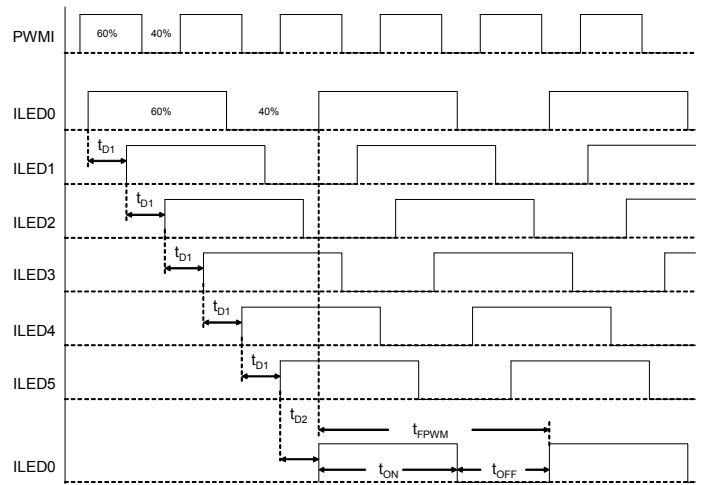

FIGURE 26. SIX EQUAL PHASE CHANNELS PHASE SHIFT ILLUSTRATION

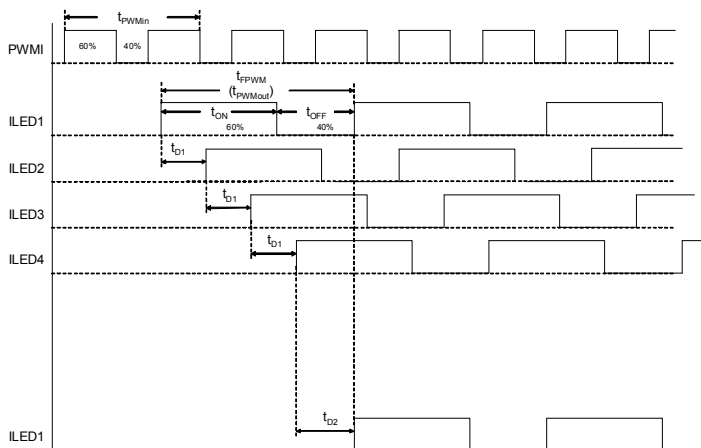

FIGURE 27. FOUR EQUAL PHASE CHANNELS PHASE SHIFT ILLUSTRATION

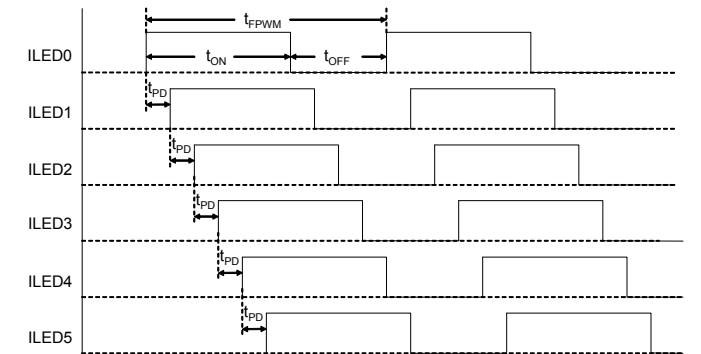

FIGURE 28. PHASE SHIFT WITH 7-BIT PROGRAMMABLE DELAY

The ISL78171 allows the user to program the amount of phase shift degree with 7-bit resolution, as shown in Figure 28. To enable programmable phase shifting, the user must write to the Phase Shift Control register with EqualPhase = 0 and the desirable phase shift value of PhaseShift[6:0]. The delay between CH5 and the repeated CH0 is the rest of the PWM cycle.

Switching Frequency

The default switching frequency is 600kHz but it can be selected to 600kHz or 1.2MHz if the SMBus/I²C communications is used. The switching frequency select bit is accessible in the SMBus/I²C Configuration Register 0x08 bit 2. Alternatively 800kHz can be selected by writing value 0x80 only to register 0x7F. The default value for register 0x7F should otherwise be set to 0x00 in order to use the 600kHz or 1.2MHz.

5V Low Dropout Regulator

An internal 5V low dropout (LDO) regulator supplies the necessary low-voltage needed for the chip's internal control circuitry. VDC is the output of this LDO regulator which requires a bypass capacitor of 1 μ F or more for the purpose of filtering & regulation. The VDC pin can be used as a coarse reference as long as it is sourcing 20mA or less.

IC Protection Features and Fault Management

ISL78171 has several protection and fault management features that improve system reliability. The following sections describe them in more detail.

INRUSH CONTROL AND SOFT-START

The ISL78171 has separate, built-in, independent inrush control and soft-start functions. The inrush control function is built around an external short-circuit protection P-channel FET in series with VIN. At start-up, the fault protection FET is turned on slowly due to a 21 μ A pull-down current output from the FAULT pin. This discharges the fault FET's gate-source capacitance, turning on the FET in a controlled fashion. As this happens, the output capacitor is charged slowly through the low-current FET before it becomes fully enhanced. This results in a low inrush current. This current can be further reduced by adding a capacitor (in the 1nF to 5nF range) across the gate source terminals of the FET.

Once the chip detects that the fault protection FET is turned on fully, it assumes that inrush is complete. At this point, the boost regulator begins to switch, and the current in the inductor ramps up. The current in the boost power switch is monitored, and switching is terminated in any cycle in which the current exceeds the current limit. The ISL78171 includes a soft-start feature in which this current limit starts at a low value (275mA). This value is stepped up to the final 2.2A current limit in seven additional steps of 275mA each. These steps happen over at least 8ms and are extended at low LED PWM frequencies if the LED duty cycle is low. This extension allows the output capacitor to charge to the required value at a low current limit and prevents high input current for systems that have only a low to medium output current requirement.

For systems with no master fault protection FET, the inrush current flows towards C_{OUT} when V_{IN} is applied. The inrush current is determined by the ramp rate of V_{IN} and the values of C_{OUT} and L.

FAULT PROTECTION AND MONITORING

The ISL78171 features extensive protection functions to cover all perceivable failure conditions.

The failure mode of an LED can be either an open circuit or a short. The behavior of an open circuited LED can additionally take the form of either infinite resistance or, for some LEDs, a Zener diode, which is integrated into the device in parallel with the now-opened LED.

For basic LEDs (which do not have built-in Zener diodes), an open-circuit failure of an LED results only in the loss of one channel of LEDs, without affecting other channels. Similarly, a short-circuit condition on a channel that results in that channel being turned off does not affect other channels unless a similar fault is occurring.

Due to the lag in boost response to any load change at its output, certain transient events (such as LED current steps or significant step changes in LED duty cycle) can transiently look like LED fault modes. The ISL78171 uses feedback from the LEDs to determine when it is in a stable operating region and prevents apparent faults during these transient events from allowing any of the LED stacks to fault out. See [Table 2](#) for details.

A fault condition that results in an input current that exceeds the boost FET current limit of 2A (typ.) will result in a shutdown of all output channels.

All LED faults are reported via the SMBus/I²C interface to Register 0x02 (Fault/Status register). The controller is able to determine which channels has failed via Register 0x09 (Output Masking register). The controller can also choose to use Register 0x09 to disable faulty channels at start-up, resulting in only further faulty channels being reported by Register 0x02.

SHORT-CIRCUIT PROTECTION (SCP)

The short-circuit detection circuit monitors the voltage on each channel and disables faulty channels that are above approximately 7.5V (this action is described in ["Protections Table" on page 17](#)).

OPEN CIRCUIT PROTECTION (OCP)

When one of the LEDs becomes an open circuit, it can behave as either an infinite resistance or as a gradually increasing finite resistance. The ISL78171 monitors the current in each channel such that any string that reaches the intended output current is considered "good." Should the current subsequently fall below the target, the channel is considered an "open circuit." Furthermore, should the boost output of the ISL78171 reach the OVP limit, or should the lower over-temperature threshold be reached, all channels that are not good are immediately considered to be open circuit. Detection of an open circuit channel results in a time-out before the affected channel is disabled. This time-out is sped up when the device is above the lower over-temperature threshold, in an attempt to prevent the upper over-temperature trip point from being reached.

Some users employ special types of LEDs that have a Zener diode structure in parallel with the LED. This configuration provides ESD enhancement and enables open circuit operation. When this type of LED is open circuited, the effect is as if the LED forward voltage has increased but the lighting level has not increased. Any affected string will not be disabled, unless the failure results in the boost OVP limit being reached, which allows all other LEDs in the string to remain functional. In this case, care should be taken that the boost OVP limit and SCP limit are set

properly, to ensure that multiple failures on one string do not cause all other good channels to fault out. This condition could arise if the increased forward voltage of the faulty channel makes all other channels look as if they have LED shorts. See [Table 2](#) for details of responses to fault conditions.

OVP AND V_{OUT}

The Overvoltage Protection (OVP) pin has a function of setting the overvoltage trip level as well as limiting the V_{OUT} regulation range.

The ISL78171 OVP threshold is set by R_{UPPER} and R_{LOWER} such that:

$$V_{OUT_OVP} = 1.22V \times \frac{(R_{UPPER} + R_{LOWER})}{R_{LOWER}} \quad (\text{EQ. 14})$$

The output voltage V_{OUT} can regulate between 64% and 100% of the V_{OUT_OVP} such that:

Allowable V_{OUT} = 64% to 100% of V_{OUT_OVP}

If R_1 and R_2 are chosen such that the OVP level is set at 40V, then V_{OUT} is allowed to operate between 25.6V and 40V. If the V_{OUT} requirement is changed to an application of six LEDs of 21V, then the OVP level must be reduced. Users should follow the $V_{OUT} = (64\% \sim 100\%)$ OVP level requirement; otherwise, the headroom control will be disturbed such that the channel voltage can be much higher than expected. This can sometimes prevent the driver from operating properly.

The resistances should be large, to minimize power loss. For example, a 316k Ω R_{UPPER} and a 10k Ω R_{LOWER} sets OVP to 39.8V. Large OVP resistors also allow C_{OUT} to discharge slowly during the PWM Off time. Parallel capacitors should also be placed across the OVP resistors such that $R_{UPPER}/R_{LOWER} = C_{LOWER}/C_{UPPER}$. Using a C_{UPPER} value of 30pF is recommended. These capacitors reduce the AC impedance of the OVP node, which is important when using high-value resistors. For example, if $R_{UPPER}/R_{LOWER} = 33/1$, then $C_{UPPER}/C_{LOWER} = 1/33$ with $C_{UPPER} = 100\text{pF}$ and $C_{LOWER} = 3.3\text{nF}$

The OVP pin is also monitored such that if it rises above and subsequently falls below 20% of the target OVP level, the input protection FET is also switched off.

UNDERVOLTAGE LOCK-OUT

If the input voltage falls below the UVLO level, the device stops switching and is reset. Operation restarts only when V_{IN} returns to the normal operating range.

INPUT OVERCURRENT PROTECTION

During a normal switching operation, the current through the internal boost power FET is monitored. If the current exceeds the current limit, the internal switch is turned off. Monitoring occurs on a cycle-by-cycle basis in a self-protecting way.

OVER-TEMPERATURE PROTECTION (OTP)

The ISL78171 includes two over-temperature thresholds. The lower threshold is set to +130°C. When this threshold is reached, any channel that is outputting current at a level significantly below the regulation target is treated as “open circuit” and is disabled after a time-out period. This time-out period is 800 μ s when it is above the lower threshold. The lower threshold isolates and disables bad channels before they cause enough power dissipation (as a result of other channels having large voltages across them) to hit the upper temperature threshold.

The upper threshold is set to +150°C. Each time this threshold is reached, the boost stops switching, and the output current sources switch off. Once the device has cooled to approximately +100°C, the device restarts, with the DC LED current level reduced to 75% of the initial setting. If dissipation persists, subsequent hitting of the limit causes identical behavior, with the current reduced in steps to 50% and finally 25%. Unless disabled via the EN pin, the device stays in an active state throughout.

For complete details of fault protection conditions, see [Figure 29](#) and [Table 2](#).

ISL78171

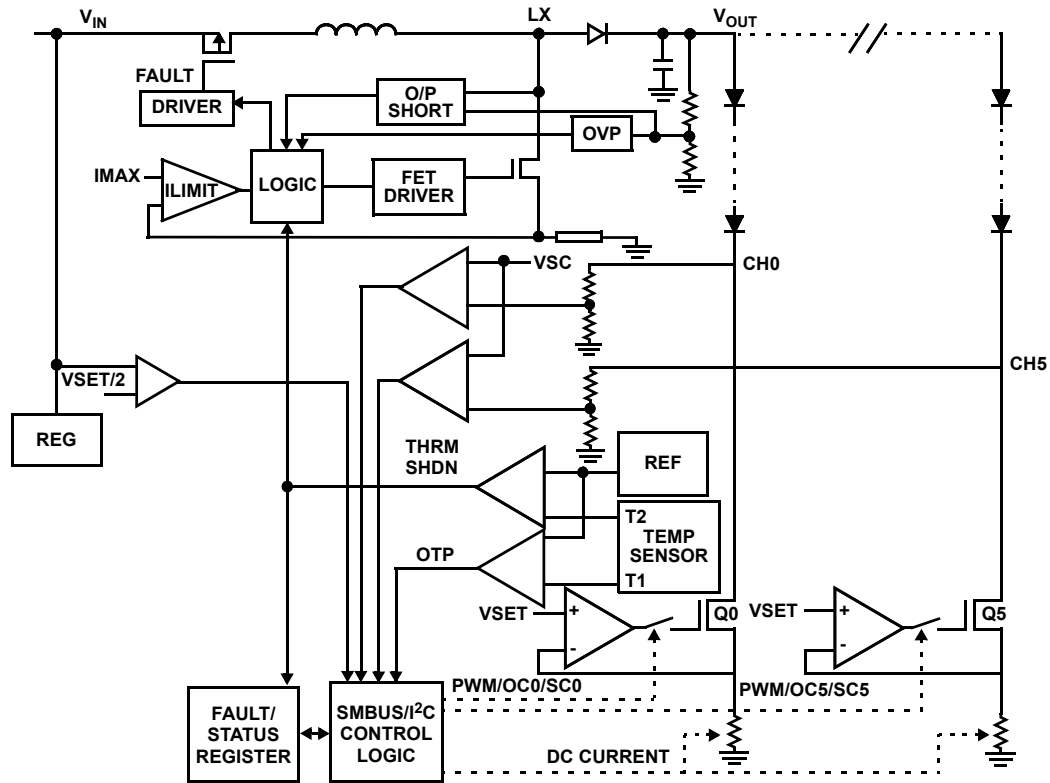

FIGURE 29. SIMPLIFIED FAULT PROTECTIONS

TABLE 2. PROTECTIONS TABLE

CASE	FAILURE MODE	DETECTION MODE	FAILED CHANNEL ACTION	GOOD CHANNELS ACTION	V _{OUT} REGULATED BY
1	CHx Short Circuit	Upper Over-Temperature Protection limit (OTP) not triggered and CHx < 7.5V	CHx ON and burns power.	Remaining channels normal	Highest VF of all channels
2	CHx Short Circuit	Upper OTP triggered but CHx < 7.5V	All channels go off until chip cooled and then comes back on with current reduced to 76%. Subsequent OTP triggers will reduce I _{OUT} further.	Same as CHx	Highest VF of remaining channels
3	CHx Short Circuit	Upper OTP not triggered but CHx > 7.5V	CHx disabled after 6 PWM cycle time-outs.	Remaining channels normal	Highest VF of remaining channels
4	CHx Open Circuit with infinite resistance	Upper OTP not triggered and CHx < 7.5V	V _{OUT} will ramp to OVP. CHx will time-out after 6 PWM cycles and switch off. V _{OUT} will drop to normal level.	Remaining channels normal	Highest VF of remaining channels
5	CHx LED Open Circuit but has paralleled Zener	Upper OTP not triggered and CHx < 7.5V	CHx remains ON and has highest VF, thus V _{OUT} increases.	Remaining channels ON, remaining channel FETs burn power	VF of CHx
6	CHx LED Open Circuit but has paralleled Zener	Upper OTP triggered but CHx < 7.5V	All channels go off until chip cooled and then comes back on with current reduced to 76%. Subsequent OTP triggers will reduce I _{OUT} further	Same as CHx	VF of CHx
7	CHx LED Open Circuit but has paralleled Zener	Upper OTP not triggered but CHx > 7.5V	CHx remains ON and has highest VF, thus V _{OUT} increases.	V _{OUT} increases, then CH-X switches OFF after 6 PWM cycles. This is an unwanted shut off and can be prevented by setting OVP at an appropriate level.	VF of CHx

ISL78171

TABLE 2. PROTECTIONS TABLE (Continued)

CASE	FAILURE MODE	DETECTION MODE	FAILED CHANNEL ACTION	GOOD CHANNELS ACTION	V _{OUT} REGULATED BY
8	Channel-to-Channel ΔV_F too high	Lower OTP triggered but CHx < 7.5V	Any channel below the target current will fault out after 6 PWM cycles. Remaining channels driven with normal current.		Highest V _F of remaining channels
9	Channel-to-Channel ΔV_F too high	Upper OTP triggered but CHx < 7.5V	All channels go off until chip cools and then come back on with current reduced to 76%. Subsequent OTP triggers will reduce I _{OUT} further.		Boost switch OFF
10	Output LED stack voltage too high	V _{OUT} > VOVP	Any channel that is below the target current will time-out after 6 PWM cycles, and V _{OUT} will return to the normal regulation voltage required for other channels.		Highest V _F of remaining channels
11	V _{OUT} /LX shorted to GND at start-up or V _{OUT} shorted in operation	LX current and timing are monitored. OVP pins monitored for excursions below 20% of OVP threshold.	The chip is permanently shutdown 31ms after power-up if V _{OUT} /Lx is shorted to GND.		

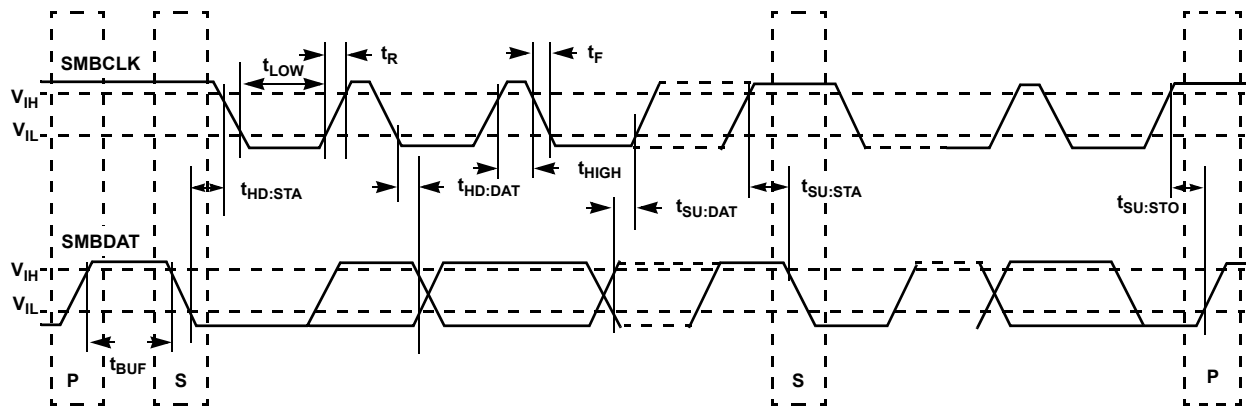

NOTES:

SMBus/I²C Description

- S = start condition
- P = stop condition
- A = acknowledge
- \bar{A} = not acknowledge
- R/W = read enable at high; write enable at low

FIGURE 30. SMBUS/I²C INTERFACE

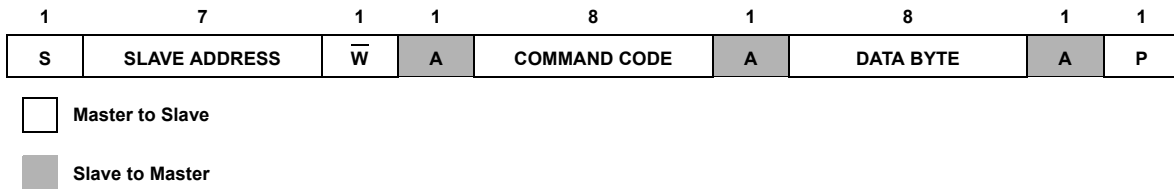

FIGURE 31. WRITE BYTE PROTOCOL

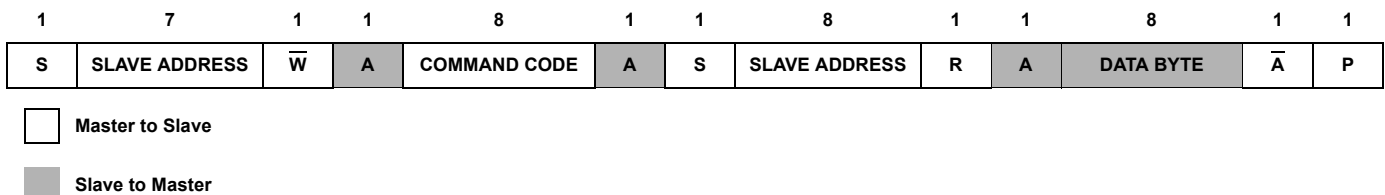

FIGURE 32. READ BYTE PROTOCOL

SMBus/I²C Communications

The ISL78171 can be controlled by SMBus/I²C for PWM or DC dimming. Except when both the SDA and SCL input pins are tied to ground, the LEDs are off by default and the user must use the SMBus/I²C interface to turn them on. When both SDA and SCL are instead shorted to ground, the LEDs turn on by default when the IC is turned on, and the customer can use the ISL78171 without having to control the SMBus/I²C interface. The switching frequency is fixed at 600kHz if SMBus/I²C is not used.

Write Byte

The Write Byte protocol is only three bytes long. The first byte starts with the slave address followed by the “command code,” which translates to the “register index” being written. The third byte contains the data byte that must be written into the register selected by the “command code”. A shaded label is used on cycles during which the slaved backlight controller “owns” or “drives” the Data line. All other cycles are driven by the “host master.”

Read Byte

Figure 32 shows that the four byte long Read Byte protocol starts out with the slave address followed by the “command code”, which translates to the “register index.” Subsequently, the bus direction turns around with the re-broadcast of the slave address with bit 0 indicating a read (“R”) cycle. The fourth byte contains the data being returned by the backlight controller. That byte value in the data byte reflects the value of the register being queried at the “command code” index. Note the bus directions, which are highlighted by the shaded label that is used on cycles during which the slaved backlight controller “owns” or “drives” the Data line. All other cycles are driven by the “host master.”

Slave Device Address

The slave address contains 7 MSB plus one LSB as R/W bit, but these 8 bits are usually called Slave Address bytes. Figure 33 shows that the high nibble of the Slave Address byte is 0x5 or 0101b to denote the “backlight controller class.” Bit 3 in the lower nibble of the Slave Address byte is 1. Bit 0 is always the R/W bit, as specified by the SMBus/I²C protocol. Note: In this document, the device address will always be expressed as a full 8-bit address instead of the shorter 7-bit address typically used in other backlight controller specifications to avoid confusion. Therefore, if the device is in the write mode where bit 0 is 0, the slave address byte is 0x58 or 01011000b. If the device is in the read mode where bit 0 is 1, the slave address byte is 0x59 or 01011001b.

SMBus/I²C Register Definitions

The backlight controller registers are Byte wide and accessible via the SMBus/I²C Read/Write Byte protocols. Their bit assignments are provided in the following sections with reserved bits containing a default value of “0”.

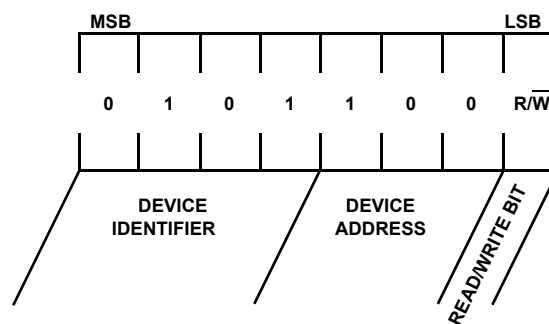

FIGURE 33. SLAVE ADDRESS BYTE DEFINITION

ISL78171

TABLE 3A. ISL78171 REGISTER LISTING

ADDRESS	REGISTER	BIT 7	BIT 6	BIT 5	BIT 4	BIT 3	BIT 2	BIT 1	BIT 0	DEFAULT VALUE	SMBUS/I ² C PROTOCOL
0x00	PWM Brightness Control Register	BRT7	BRT6	BRT5	BRT4	BRT3	BRT2	BRT1	BRT0	0xFF	Read and Write
0x01	Device Control Register	Reserved	Reserved	Reserved	Reserved	Reserved	PWM_MD	PWM_SEL	BL_CTL	0x00	Read and Write
0x02	Fault/Status Register	Reserved	Reserved	2_CH_SD	1_CH_SD	BL_STAT	OV_CURR	THRM_SHDN	FAULT	0x00	Read Only Note 11)
0x03	Identification Register	LED Panel	MFG3	MFG2	MFG1	MFG0	REV2	REV1	REV0	0xC8	Read Only
0x07	DC Brightness Control Register	BRTDC7	BRTDC6	BRTDC5	BRTDC4	BRTDC3	BRTDC2	BRTDC1	BRTDC0	0xFF	Read and Write
0x08	Configuration Register	Reserved	Reserved	Reserved	BstSlew Rate1	BstSlew Rate0	FSW	Reserved	VSC	0x1F	Read and Write
0x09	Output Channel Register	Reserved	Reserved	CH5	CH4	CH3	CH2	CH1	CH0	0x3F	Read and Write
0x0A	Phase Shift Deg	Equal Phase	Phase Shift6	Phase Shift5	Phase Shift4	Phase Shift3	Phase Shift2	Phase Shift1	Phase Shift0	0x00	Read and Write
0x7F Note 10)	Secondary Boost Oscillator	Enable	Must be 0	Must be 0	Must be 0	Must be 0	Must be 0	Must be 0	Must be 0	0x00	Read and Write

TABLE 3B. DATA BIT DESCRIPTIONS

ADDRESS	REGISTER	DATA BIT DESCRIPTIONS
0x00	PWM Brightness Control Register	BRT[7..0] = 256 steps of DPWM duty cycle brightness control
0x01	Device Control Register	PWM_MD, PWM_SEL: select the dimming method - see Table 4 for more details. Default = 00 BL_CTL = BL On/Off (1 = On, 0 = Off), default = 0
0x02	Fault/Status Register	2_CH_SD = Two LED output channels are shutdown (1 = shutdown, 0 = OK) 1_CH_SD = One LED output channel is shutdown (1 = shutdown, 0 = OK) BL_STAT = BL status (1 = BL On, 0 = BL Off) OV_CURR = Input overcurrent (1 = Overcurrent condition, 0 = Current OK) THRM_SHDN = Thermal Shutdown (1 = Thermal fault, 0 = Thermal OK) FAULT = Fault occurred (Logic "OR" of all of the fault conditions)
0x03	Identification Register	LED PANEL = 1 MFG[3..0] = Manufacturer ID (16 vendors available. Intersil is vendor ID 9) REV[2..0] = Silicon rev (Rev 0 through Rev 7 allowed for silicon spins)
0x07	DC Brightness Control Register	BRTDC[7..0] = 256 steps of DC brightness control
0x08	Configuration Register	BstSlewRate[1..0] = Controls strength of FET driver. 00 - 25% drive strength, 01 - 50% drive strength, 10 - 75% drive strength, 11 - 100% drive strength. f _{SW} = Switching frequencies selection, f _{SW} = 0 = 1.2MHz. f _{SW} = 1 = 600kHz VSC[0] = Short circuit thresholds selection, 0 = disabled, 1 = 7.5V minimum
0x09	Output Channel Mask/Fault Readout Register	CH[5..0] = Output Channel Read and Write. In Write, 1 = Channel Enabled, 0 = Channel Disabled. In Read, 1 = Channel OK, 0 = Channel Not OK/Channel disabled
0x0A	Phase Shift Degree	EqualPhase = Controls phase shift mode - When 1, phase shift is 360/N (where N is the number of channels enabled). When 0, phase shift is defined by PhaseShift<6:0>. PS[6..0] = 7-bit Phase shift setting - phase shift between each channel is PhaseShift<6:0>/(255*PWMFreq). In direct PWM modes, phase shift between each channel is PhaseShift<6:0>/12.8MHz.
0x7F Note 10)	Secondary Boost Oscillator	Enable = 1: Use the secondary boost oscillator 800kHz OR Enable = 0, use the primary 600kHz/1.2MHz oscillator.

10. Bit 7 of an additional register 0x7F that allows selecting an override boost frequency of 800kHz. This is done by writing 0x80 to register 0x7F. The default value for register 0x7F is 0x00 when either 600kHz or 1.2MHz boost frequency is being used. Please ensure that the rest of the bits 0-6 in register 0x7F should remain at 0 at all times, failing to do so will adversely affect the PWM performance of the LED.

11. FAULT is a Read & Write bit.

PWM Brightness Control Register (0x00)

The brightness control resolution has 256 steps of PWM duty cycle adjustment. [Figure 34](#) shows the bit assignment. All of the bits in this Brightness Control Register can be read or written. Step 0 corresponds to the minimum step where the current is less than 10µA. Steps 1 to 255 represent the linear steps between 0.39% and 100% duty cycle with approximately 0.39% duty cycle adjustment per step.

- An SMBus/I²C Write Byte cycle to Register 0x00 sets the PWM brightness level only if the backlight controller is in SMBus/I²C mode (see [Table 4](#)) Operating Modes selected by Device Control Register Bits 1 and 2).
- An SMBus/I²C Read Byte cycle to Register 0x00 returns the programmed PWM brightness level.
- An SMBus/I²C setting of 0xFF for Register 0x00 sets the backlight controller to the maximum brightness.
- An SMBus/I²C setting of 0x00 for Register 0x00 sets the backlight controller to the minimum brightness output.
- Default value for Register 0x00 is 0xFF.

REGISTER 0x00	PWM BRIGHTNESS CONTROL REGISTER
----------------------	--

BRT7	BRT6	BRT5	BRT4	BRT3	BRT2	BRT1	BRT0
Bit 7 (R/W)	Bit 6 (R/W)	Bit 5 (R/W)	Bit 4 (R/W)	Bit 3 (R/W)	Bit 2 (R/W)	Bit 1 (R/W)	Bit 0 (R/W)

BIT ASSIGNMENT	BIT FIELD DEFINITIONS
BRT[7..0]	= 256 steps of PWM brightness levels

FIGURE 34. DESCRIPTIONS OF BRIGHTNESS CONTROL REGISTER

REGISTER 0x01	DEVICE CONTROL REGISTER
----------------------	--------------------------------

RESERVED	RESERVED	RESERVED	RESERVED	RESERVED	PWM_MD	PWM_SEL	BL_CTL
Bit 7 (R/W)	Bit 6 (R/W)	Bit 5 (R/W)	Bit 4 (R/W)	Bit 3 (R/W)	Bit 2 (R/W)	Bit 1 (R/W)	Bit 0 (R/W)

PWM_MD	PWM_SEL	BL_CTL	MODE
X	X	0	Backlight Off
0	0	1	SMBus/I ² C and PWM input controlled Display Power Saving Technology (DPST) dimming (Method 3, PWMI x PWM Reg & FPWM)
1	0	1	SMBus/I ² C controlled PWM dimming (Method 1, PWM Reg & FPWM)
X	1	1	PWM input controlled PWM dimming (Method 2, PWMI & FPWM)

FIGURE 35. DESCRIPTIONS OF DEVICE CONTROL REGISTER

Device Control Register (0x01)

This register has two bits that control either SMBus/I²C controlled or external PWM controlled PWM dimming and a single bit that controls the backlight ON/OFF state. The remaining bits are reserved. The bit assignment is shown in [Figure 35](#). All other bits in the Device Control Register will read as low unless otherwise written.

- All reserved bits have no functional effect when written.
- All defined control bits return their current, latched value when read.

A value of 1 written to BL_CTL turns on the backlight in 4ms or less after the write cycle completes. The backlight is deemed to be on when Bit 3 BL_STAT of Register 0x02 is 1 and Register 0x09 is not 0.

A value of 0 written to BL_CTL immediately turns off the BL. The BL is deemed to be off when Bit 3 BL_STAT of Register 0x02 is 0 and Register 0x09 is 0.

The default value for Register 0x01 is 0x00.

TABLE 4. OPERATING MODES SELECTED BY DEVICE CONTROL REGISTER BITS 1 AND 2

PWM_MD	PWM_SEL	MODE
0	0	SMBus/I ² C and PWM input controlled Display Power Saving Technology (DPST) dimming (Method 3, PWMI x PWM Reg & FPWM)
1	0	SMBus/I ² C controlled PWM dimming (Method 1, PWM Reg & FPWM)
X	1	PWM input controlled PWM dimming (Method 2, PWMI & FPWM)

The PWM_SEL bit determines whether the SMBus/I²C or PWM input should drive the output brightness in terms of PWM dimming. When PWM_SEL bit is 1, only the PWM input drives the output brightness regardless of whether a 0 or 1 is stored in PWM_MD.

When the PWM_SEL bit is set to 0, the PWM_MD bit selects the manner in which the PWM dimming is to be interpreted; when this bit is 1, the PWM dimming is based on the SMBus/I²C brightness register setting only. When this bit is set to 0, the PWM dimming reflects a percentage change in the current brightness programmed in the SMBus/I²C Register 0x00, i.e., DPST (Display Power Saving Technology) mode as:

$$\text{DPST Brightness} = \text{Cbt} \times \text{PWMI} \quad (\text{EQ. 15})$$

Where:

PWM = is the percent duty cycle of the PWM input

Cbt = Current brightness setting from SMBus/I²C Register 0x00 (BRT) without influence from the PWM input:

$$\text{Cbt} = \frac{(\text{BRT})}{255} \quad (\text{EQ. 16})$$

Where BRT is the value programmed in the PWM brightness Register 0x00. BRT ranges from 0 to 255 in decimal and defaults to 255 (0xFF). BRT = 0 disconnects all channels.

For example, the Cbt = 50% is the duty cycle programmed in the SMBus/I²C Register 0x00 and the PWM frequency is tuned to be 200Hz with an appropriate resistor at the FPWM pin. And if the PWMI is fed with a 1kHz 30% high PWM signal, while setting PWM_SEL = 0 and PWM_MD = 0, the device is in the DPST mode of operation, the resultant DPST brightness will be a 15% PWM dimming at 200Hz.

Fault/Status Register (0x02)

This register has 6 status bits that allow monitoring of the backlight controller's operating state. Not all of the bits in this register are fault related (Bit 3 is a simple BL status indicator). The remaining bits are reserved and return a "0" when a read is executed and ignored the bit value when written. All of the bits in this register are read-only, with the exception of bit 0, which can be cleared by writing to it.

- BL_STAT indicates the current back light on/off status in BL_STAT (1 if the BL is on, 0 if the BL is off).
- FAULT is the logical OR of THRM_SHDN, OV_CURR, 2_CH_SD, and 1_CH_SD should these events occur.
- 1_CH_SD returns a 1 if one or more channels have faulted out.
- 2_CH_SD returns a 1 if two or more channels have faulted out.
- When FAULT is set to 1, it will remain at 1 even if the signal which sets it goes away. FAULT will be cleared when the BL_CTL bit of the Device Control Register is toggled or when a 0 is written into the FAULT bit. At that time, if the fault condition is still present or reoccurs, FAULT will be set to 1 again. BL_STAT will not cause FAULT to be set.
- The default value for Register 0x02 is 0x00.

REGISTER 0x02	FAULT/STATUS REGISTER
---------------	-----------------------

RESERVED	RESERVED	2_CH_SD	1_CH_SD	BL_STAT	OV_CURR	THRM_SHDN	FAULT
Bit 7 (R)	Bit 6 (R)	Bit 5 (R)	Bit 4 (R)	Bit 3 (R)	Bit 2 (R)	Bit 1 (R)	Bit 0 (R/W)

BIT	BIT ASSIGNMENT	BIT FIELD DEFINITIONS
Bit 5	2_CH_SD	= Two LED output channels are shutdown (1 = shutdown, 0 = OK)
Bit 4	1_CH_SD	= One LED output channel is shutdown (1 = shutdown, 0 = OK)
Bit 3	BL_STAT	= BL Status (1 = BL On, 0 = BL Off)
Bit 2	OV_CURR	= Input Overcurrent (1 = Overcurrent condition, 0 = Current OK)
Bit 1	THRM_SHDN	= Thermal Shutdown (1 = Thermal Fault, 0 = Thermal OK)
Bit 0	FAULT	= Fault occurred (Logic "OR" of all of the fault conditions)

FIGURE 36. DESCRIPTIONS OF FAULT/STATUS REGISTER

Identification Register (0x03)

The ID register contains 3-bit fields to denote the LED driver (always set to 1), manufacturer and the silicon revision of the controller IC. The bit field widths allow up to 16 vendors with up to 8 silicon revisions each. All of the bits in this register are read-only.

- Vendor ID 9 represents Intersil Corporation
- The default value for Register 0x03 is 0xC8

The initial value of REV shall be 0. Subsequent values of REV will increment by 1.

DC Brightness Control Register (0x07)

The DC Brightness Control Register 0x07 sets the LED current level between 0% and 100% of the level set using the RSET pin. When PWM dimming, the level set is the current during the on time. This register allows users to have additional dimming flexibility by:

1. Effectively achieving 16-bits of dimming control when DC dimming is combined with PWM dimming
2. Achieving visual or audio noise free 8-bit DC dimming over potentially noisy PWM dimming.

The bit assignment is shown in [Figure 38](#). All of the bits in this Register can be read or written. Steps 0 to 255 represent the linear steps of DC current adjustment on-the-fly.

- An SMBus/I²C Write Byte cycle to Register 0x07 sets the DC LED current level.
- An SMBus/I²C Read Byte cycle to Register 0x07 returns the DC LED current.
- Default value for Register 0x07 is 0xFF.

REGISTER 0x03		ID REGISTER					
LED PANEL	MFG3	MFG2	MFG1	MFG0	REV2	REV1	REV0
Bit 7 = 1	Bit 6 (R)	Bit 5 (R)	Bit 4 (R)	Bit 3 (R)	Bit 2 (R)	Bit 1 (R)	Bit 0 (R)

BIT ASSIGNMENT	BIT FIELD DEFINITIONS
MFG[3..0]	= Manufacturer ID. See " Identification Register (0x03) " on page 23. data 0 to 8 in decimal correspond to other vendors data 9 in decimal represents Intersil ID data 10 to 14 in decimal are reserved data 15 in decimal Manufacturer ID is not implemented
REV[2..0]	= Silicon rev (Rev 0 through Rev 7 allowed for silicon spins)

FIGURE 37. DESCRIPTIONS OF ID REGISTER

REGISTER 0x07		DC BRIGHTNESS CONTROL REGISTER					
BRTDC7	BRTDC6	BRTDC5	BRTDC4	BRTDC3	BRTDC2	BRTDC1	BRTDC0
Bit 7 (R/W)	Bit 6 (R/W)	Bit 5 (R/W)	Bit 4 (R/W)	Bit 3 (R/W)	Bit 2 (R/W)	Bit 1 (R/W)	Bit 0 (R/W)

BIT ASSIGNMENT	BIT FIELD DEFINITIONS
BRTDC[7..0]	= 256 steps of DC brightness levels

FIGURE 38. DESCRIPTIONS OF DC BRIGHTNESS CONTROL REGISTER

Configuration Register (0x08)

The Configuration Register provides many extra functions that users can explore in order to optimize the driver performance at a given application.

A BstSlewRate bit allows users to control the boost FET slew rate (the rates of turn-on and turn-off). The slew rate can be selected up to four relative strengths when driving the internal boost FET. The purpose of this function is to allow users to experiment with the slew rate in order to meet to EMI compliance in the system. In general, the slower the slew rate is, the lower the EMI interference to the surrounding circuits, this however causes an increase in the switching loss of the boost FET.

The FSW bit allows users to set the boost converter switching frequency between 1.2MHz and 600kHz. The VSC bit allows users to set the LED string short circuit threshold VSC to 7.5V or disable it. If VSC function is enabled then the forward voltages across the LED string matching must be less than 7.5V.

The bit assignment is shown in [Figure 39](#). The default value for Register 0x08 is 0x1F.

REGISTER 0x08		CONFIGURATION REGISTER					
RESERVED	RESERVED	BIT5	BIT4	BIT3	FSW	RESERVED	VSC
Bit 7 (R/W)	Bit 6 (R/W)	Bit 5 (R/W)	Bit 4 (R/W)	Bit 3 (R/W)	Bit 2 (R/W)	Bit 1 (R/W)	Bit 0 (R/W)

BIT ASSIGNMENT	BIT FIELD DEFINITIONS
BstSlewRate[1..0]	Controls strength of FET driver. 00 - 25% drive strength, 01 to 50% drive strength, 10 - 75% drive strength, 11 to 100% drive strength.
FSW	2 levels of Switching Frequencies (0= 1,200kHz, 1 = 600kHz)
VSC	Enable/Disable Short Circuit Protection (0 = disabled, 1 = 7.5V minimum)

FIGURE 39. DESCRIPTIONS OF CONFIGURATION REGISTER

REGISTER 0x09		OUTPUT CHANNEL REGISTER					
RESERVED	RESERVED	CH5	CH4	CH3	CH2	CH1	CH0
Bit 7 (R/W)	Bit 6 (R/W)	Bit 5 (R/W)	Bit 4 (R/W)	Bit 3 (R/W)	Bit 2 (R/W)	Bit 1 (R/W)	Bit 0 (R/W)

BIT ASSIGNMENT	BIT FIELD DEFINITIONS
CH[5..0]	CH5 = Channel 5, CH4 = Channel 4 and so on

FIGURE 40. OUTPUT CHANNEL REGISTER

Output Channel Mask/Fault Readout Register (0x09)

This register can be read or written. It allows enabling and disabling each channel individually. The bit position corresponds to the channel. For example, Bit 0 corresponds to Ch0 and bit 5 corresponds to Ch5 and so on. A 1 bit value enables the channel of interest. When reading data from this register, any disabled channel and any faulted out channel will read as 0. This allows the user to determine which channel is faulty and optionally not enabling it in order to allow the rest of the system to continue to function. Additionally, a faulted out channel can be disabled and re-enabled in order to allow a retry for any faulty channel without having to power-down the other channels.

The bit assignment is shown in [Figure 40](#). The default for Register 0x09 is 0x3F.

REGISTER 0x0A		PHASE SHIFT CONTROL REGISTER					
EQUALPHASE	PHASESHIFT6	PHASESHIFT5	PHASESHIFT4	PHASESHIFT3	PHASESHIFT2	PHASESHIFT1	PHASESHIFT0
Bit 7 (R/W)	Bit 6 (R/W)	Bit 5 (R/W)	Bit 4 (R/W)	Bit 3 (R/W)	Bit 2 (R/W)	Bit 1 (R/W)	Bit 0 (R/W)

BIT ASSIGNMENT	BIT FIELD DEFINITIONS
EqualPhase	Controls phase shift mode - When 0, phase shift is defined by PhaseShift<6:0>. When 1, phase shift is 360/N (where N is the number of channels enabled).
PhaseShift[6..0]	7-bit Phase shift setting - phase shift between each channel is PhaseShift<6:0>/(255*PwmFreq)

FIGURE 41. DESCRIPTIONS OF PHASE SHIFT CONTROL REGISTER

Phase Shift Control Register (0x0A)

The Phase Shift Control register is used to set phase delay between channels. When Bit 7 is set high, the phase delay is set by the number of channels enabled and the PWM frequency. Referring to [Figure 3](#), the delay time is defined by [Equation 17](#):

$$t_{D1} = (t_{FPWM}/N) \quad (\text{EQ. 17})$$

Where N is the number of channels enabled, and t_{FPWM} is the period of the PWM cycle. When Bit 7 is set low, the phase delay is set by bits 6 to 0 and the PWM frequency. Referencing [Figure 28](#), the programmable delay time is defined by [Equation 18](#):

$$t_{PD} = (PS < 6, 0 > \times t_{FPWM} / (255)) \quad (\text{EQ. 18})$$

Where PS is an integer from 0 to 127, and t_{FPWM} is the period of the PWM cycle. By default, all the register bits are set low, which sets zero delay between each channel. Note that the user should not program the register to have more than one period of the PWM cycle delay between the first and last enabled channels.

Secondary Boost Oscillator Register (0x7F)

The Secondary Boost Oscillator Register allows selecting a secondary 800kHz oscillator to drive the LX pin switching frequency, overriding the primary switching frequency selected in Configuration Register. For those applications where the switching frequency of the LX node may cause interference with such functions as an AM radio tuner, etc, a secondary oscillator with typical frequency of 800kHz is provided to help minimize interference. Selection of the 800kHz oscillator is done by writing 0x80 to register 0x7F. The default value for register 0x7F is 0x00 when either 600kHz or 1.2MHz boost frequency is being used. It is to be ensured that the rest of the bits 0-6 in register 0x7F should remain at 0 at all times, failing to do so will adversely affect the PWM performance.

Component Selection

According to the inductor Voltage-Second Balance principle, the change of inductor current during the switching regulator On time is equal to the change of inductor current during the switching regulator Off time. As shown in [Equations 19](#) and [20](#), since the voltage across an inductor is:

$$\Delta I_L = \frac{V_L}{L} \times \Delta t \quad (\text{EQ. 19})$$

and ΔI_L at On = ΔI_L at Off, therefore:

$$(V_1 - 0)/L \times D \times t_S = (V_O - V_D - V_1)/L \times (1 - D) \times t_S \quad (\text{EQ. 20})$$

Where D is the switching duty cycle defined by the turn-on time over the switching period. V_D is a Schottky diode forward voltage that can be neglected for approximation.

Rearranging the terms without accounting for V_D gives the boost ratio and duty cycle, respectively, as shown in [Equations 21](#) and [22](#):

$$V_O/V_1 = 1/(1 - D) \quad (\text{EQ. 21})$$

$$D = (V_O - V_1)/V_O \quad (\text{EQ. 22})$$

Input Capacitor

Switching regulators require input capacitors to deliver peak charging current and to reduce the impedance of the input supply. The capacitors reduce interaction between the regulator and input supply, thus improving system stability. The high switching frequency of the loop causes almost all ripple current to flow into the input capacitor, which must be rated accordingly.

A capacitor with low internal series resistance should be chosen to minimize heating effects and to improve system efficiency. The X5R and X7R ceramic capacitors offer small size and a lower value for temperature and voltage coefficient compared to other ceramic capacitors.

An input capacitor of 10 μ F is recommended. Ensure that the voltage rating of the input capacitor is able to handle the full supply range.

Inductor

Inductor selection should be based on its maximum current (I_{SAT}) characteristics, power dissipation (DCR), EMI susceptibility (shielded vs unshielded), and size. Inductor type and value influence many key parameters, including ripple current, current limit, efficiency, transient performance, and stability.

Inductor maximum current capability must be adequate to handle the peak current in the worst-case condition. If an inductor core with too low a current rating is chosen, saturation in the core will cause the effective inductor value to fall, leading to an increase in peak-to-average current level, poor efficiency, and overheating in the core. The inductor series resistance, DCR, causes conduction loss and heat dissipation. A shielded inductor is usually more suitable for EMI-susceptible applications such as LED back light.

The peak current can be derived from the voltage across the inductor during the Off period, as shown in [Equation 23](#):

$$I_{L_{peak}} = (V_O \times I_O) / (85\% \times V_I) + 1/2[V_I \times (V_O - V_I) / (L \times V_O \times f_S)] \quad (\text{EQ. 23})$$

The value of 85% is an average term for the efficiency approximation. The first term is average current that is inversely proportional to the input voltage. The second term is inductor current change that is inversely proportional to L and f_S . As a result, for a given switching frequency and minimum input voltage at which the system operates, the inductor I_{SAT} must be chosen carefully.

Output Capacitors

The output capacitor smooths the output voltage and supplies load current directly during the conduction phase of the power switch. Output ripple voltage consists of discharge and charge of the output capacitor during FET ON and OFF time and the voltage drop due to flow through the ESR of the output capacitor. The ripple voltage can be shown as [Equation 24](#):

$$\Delta V_{CO} = (I_O / C_O \times D / f_S) + (I_O \times \text{ESR}) \quad (\text{EQ. 24})$$

The conservation of charge principle shown in [Equation 22](#) also indicates that, during the boost switch Off period, the output capacitor is charged with the inductor ripple current, minus a relatively small output current in boost topology. As a result, the user must select an output capacitor with low ESR and adequate input ripple current capability.

Note: Capacitors have a voltage coefficient that makes their effective capacitance drop as the voltage across them increases. C_{OUT} in [Equation 24](#) assumes the effective value of the capacitor at a particular voltage and not the manufacturer's stated value, measured at 0V.

Output Ripple

ΔV_{CO} can be reduced by increasing C_O or f_{SW} , or using small ESR capacitors. In general, ceramic capacitors are the best choice for output capacitors in small to medium sized LCD backlight applications due to their cost, form factor and low ESR.

A larger output capacitor will also ease the driver response during PWM dimming Off period due to the longer sample and hold effect of the output drooping. The driver does not need to boost harder in the next On period that minimizes transient current. The output capacitor is also needed for compensation, and, in general 2x4.7 μ F/50V ceramic capacitors are suitable for notebook display backlight applications.

Schottky Diode

A high-speed rectifier diode is necessary to prevent excessive voltage overshoot. Schottky diodes are recommended because of their fast recovery time, low forward voltage and reverse leakage current, which minimize losses. The reverse voltage rating of the selected Schottky diode must be higher than the maximum output voltage. Also the average/peak current rating of the Schottky diode must meet the output current and peak inductor current requirements.

Applications

High Current Applications

Each channel of the ISL78171 can support up to 30mA (50mA at $V_{IN} = 12V$). For applications that need higher current, multiple channels can be grouped to achieve the desired current ([Figure 42](#)). For example, the cathode of the last LED can be connected to CH0 through CH2; this configuration can be treated as a single string with 90mA current driving capability.

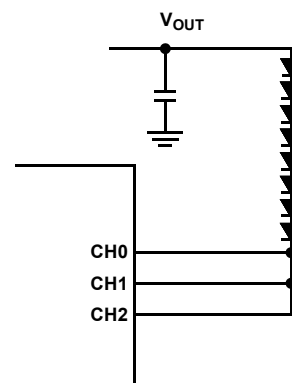

FIGURE 42. GANGING MULTIPLE CHANNELS FOR HIGH CURRENT APPLICATIONS

Low Voltage Operations

The ISL78171 V_{IN} pin can be separately biased from the LED power input to allow low-voltage operation. For systems that have only a single supply, V_{OUT} can be tied to the driver V_{IN} pin to allow initial start-up ([Figure 43](#)). The circuit works as follows: when the input voltage is available and the device is not enabled, V_{OUT} follows V_{IN} with a Schottky diode voltage drop. The V_{OUT} boot-strapped to the V_{IN} pin allows initial start-up, once the part is enabled. Once the driver starts up with V_{OUT} regulating to the target, the V_{IN} pin voltage also increases. As long as V_{OUT} does not exceed 26.5V and the extra power loss on V_{IN} is acceptable, this configuration can be used for input voltage as low as 3.0V. The Fault Protection FET feature cannot be used in this configuration.

For systems that have dual supplies, the V_{IN} pin can be biased from 5V to 12V, while input voltage can be as low as 2.7V ([Figure 44](#)). In this configuration, V_{BIAS} must be greater than or equal to V_{IN} to use the fault FET.

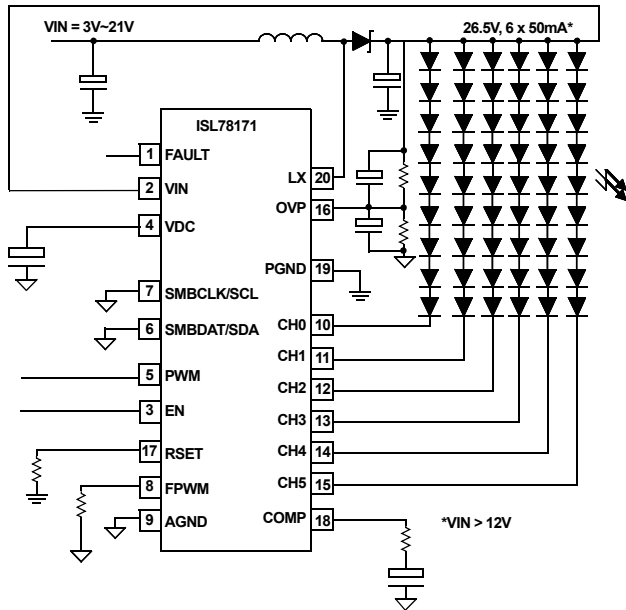

FIGURE 43. SINGLE SUPPLY 3V OPERATION

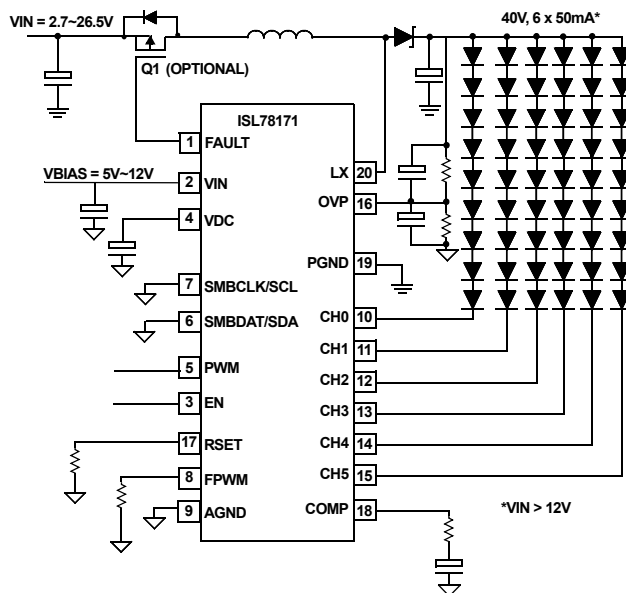

FIGURE 44. DUAL SUPPLIES 2.7V OPERATION

16-Bit Dimming

The SMBus/I²C controlled PWM and DC dimming can be combined to effectively provide 16 bits of dimming capability, which can be valuable for automotive and avionics display applications.

Field Sequential RGB LED Backlighting

The ISL78171 allows to turn each channel ON and OFF independently. In field sequential RGB LED application, it is possible to have different DC current and PWM duty cycle for different channels as long as only one channel is active at a time. This is achieved by continuously setting a new DC current and/or PWM duty cycle each time a channel is turned ON. ISL78171 does not allow to have different DC currents or PWM duty cycles for channels that are ON at the same time.

Compensation

The ISL78171 incorporates a transconductance amplifier in its feedback path to allow the user to optimize boost stability and transient response. The ISL78171 uses current mode control architecture, which has a fast current sense loop and a slow voltage feedback loop. The fast current feedback loop does not require any compensation, but for stable operation, the slow voltage loop must be compensated. The compensation is a series of R_c , C_{c1} network from COMP pin to ground, with an optional C_{c2} capacitor connected between the COMP pin and ground. The R_c sets the high-frequency integrator gain for fast transient response, and the C_{c1} sets the integrator zero to ensure loop stability. For most applications, the component values in Figure 45 can be used: R_c is 10k Ω and C_{c1} is 3.3nF. Depending upon the PCB layout, for stability, a C_{c2} of 390pF may be needed to create a pole to cancel the output capacitor ESR's zero effect.

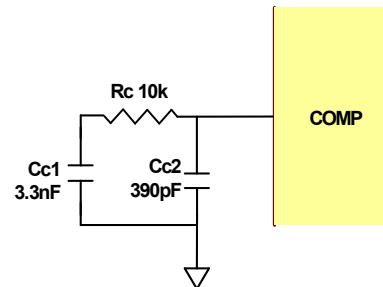

FIGURE 45. COMPENSATION CIRCUIT

Revision History

The revision history provided is for informational purposes only and is believed to be accurate, but not warranted. Please go to web to make sure you have the latest Rev.

DATE	REVISION	CHANGE
June 15, 2015	FN8602.0	Initial Release.

About Intersil

Intersil Corporation is a leading provider of innovative power management and precision analog solutions. The company's products address some of the largest markets within the industrial and infrastructure, mobile computing and high-end consumer markets.

For the most updated datasheet, application notes, related documentation and related parts, please see the respective product information page found at www.intersil.com.

You may report errors or suggestions for improving this datasheet by visiting www.intersil.com/ask.

Reliability reports are also available from our website at www.intersil.com/support

For additional products, see www.intersil.com/en/products.html

Intersil Automotive Qualified products are manufactured, assembled and tested utilizing TS16949 quality systems as noted in the quality certifications found at www.intersil.com/en/support/qualandreliability.html

Intersil products are sold by description only. Intersil Corporation reserves the right to make changes in circuit design, software and/or specifications at any time without notice. Accordingly, the reader is cautioned to verify that data sheets are current before placing orders. Information furnished by Intersil is believed to be accurate and reliable. However, no responsibility is assumed by Intersil or its subsidiaries for its use; nor for any infringements of patents or other rights of third parties which may result from its use. No license is granted by implication or otherwise under any patent or patent rights of Intersil or its subsidiaries.

For information regarding Intersil Corporation and its products, see www.intersil.com

Package Outline Drawing

L20.3x4

20 LEAD QUAD FLAT NO-LEAD PLASTIC PACKAGE

Rev 1, 3/10

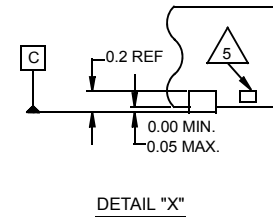
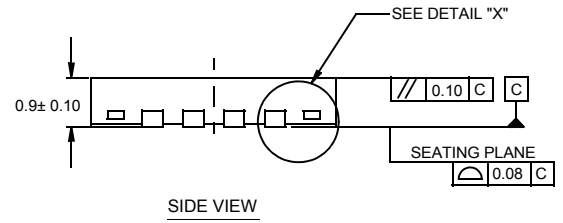
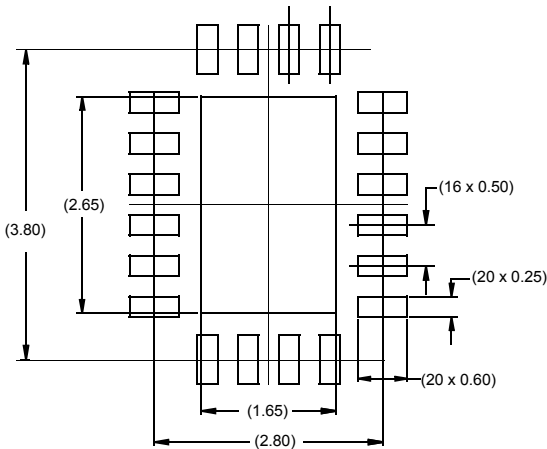
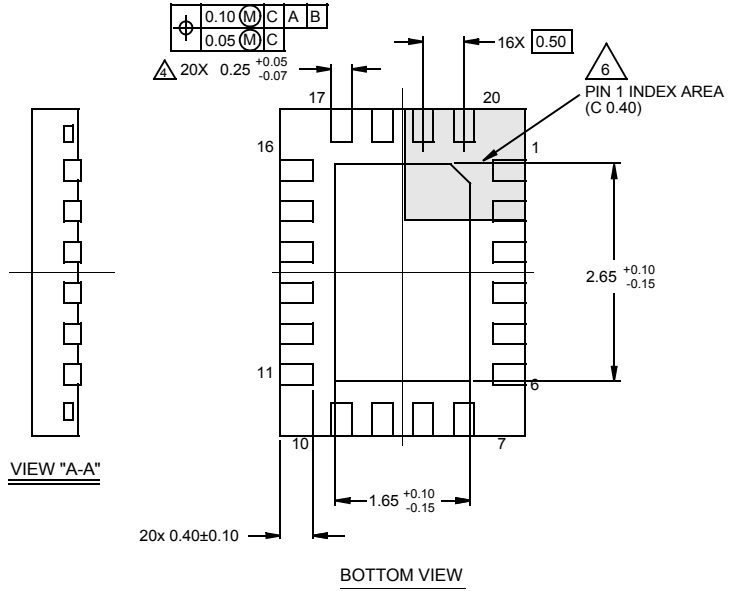
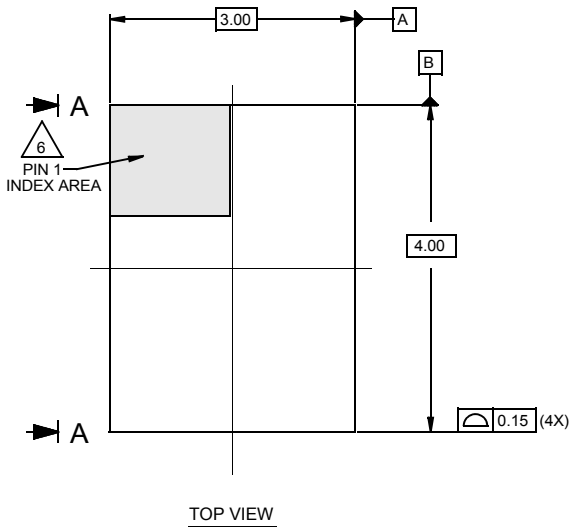

NOTES:

- Dimensions are in millimeters.
Dimensions in () for Reference Only.
- Dimensioning and tolerancing conform to AMSE Y14.5m-1994.
- Unless otherwise specified, tolerance : Decimal ± 0.05
- Dimension applies to the metallized terminal and is measured between 0.15mm and 0.30mm from the terminal tip.
- Tiebar shown (if present) is a non-functional feature.
- The configuration of the pin #1 identifier is optional, but must be located within the zone indicated. The pin #1 identifier may be either a mold or mark feature.

Mouser Electronics

Authorized Distributor

Click to View Pricing, Inventory, Delivery & Lifecycle Information:

[Intersil:](#)

[ISL78171ARZ](#) [ISL78171ARZ-T](#) [ISL78171ARZ-T7A](#)