

SaBLE-x-R2™
2.4 GHz Bluetooth® 5
Low Energy Module



Actual size (11.6 mm x 17.9 mm)

PRODUCT DESCRIPTION

SaBLE-x-R2 is a certified Bluetooth® Low Energy module built to deliver unmatched RF and power performance. This module can deliver over twice the signal range of previous generation Bluetooth low energy technology, and can operate at nearly 1/3 the average power for a 1 second connection interval when compared to previous Bluetooth low energy modules. Based on the new TI SimpleLink™ Bluetooth® Low Energy CC2640R2F wireless microcontroller (MCU), this self-contained module provides unmatched integration, including an ARM Cortex-M3 application processor, ARM Cortex-M0 processor for the RF core, Sensor Processor Engine, flash memory, and high- and low-speed clocks.

NOW WITH BLUETOOTH 5

The SaBLE-x-R2 is better with Bluetooth 5. The latest revision of the Bluetooth standard brings four times the range, twice the speed, and eight times the message capacity to low energy devices. These enhancements bring better performance, increased battery life, and a better experience to BLE applications. The SaBLE-x-R2 takes full advantage of these upgrades, as well as includes increased availability flash memory for application usage and OTA capabilities. And since it's pin-compatible with the previous SaBLE-X, it provides a simple, easy hardware upgrade path to Bluetooth 5 for customers of the previous SaBLE-x module.

FEATURES AND BENEFITS

- Features ARM Cortex-M3 processor for host applications and an ARM Cortex-M0 dedicated for the RF core
- Dedicated Sensor Processor for even lower power operation
- Integrated flash memory, *Bluetooth* low energy stack, and high- and low-speed clocks
- Pending Certifications: CC (USA), IC (Canada), ETSI (Europe), Giteki (Japan), RCM (AU/NZ)
- Multiple certified antenna options
Trace, Dipole, FlexPIFA™, and FlexNotch™
LSR offers in-house certification of additional antennas at little or no cost

Practical Applications:

Sensors, Lighting, Security, Home Automation, Sports and Fitness

SaBLE-x-R2 MODULE PERFORMANCE

SPECIFICATION	VALUE
Footprint	11.6 mm x 17.9 mm x 2.3 mm
Operating Temp	-40 to +85° C
Operating Voltage	1.8 V to 3.8 V
Output Power	+5 dBm
Receive Sensitivity	-96 dBm, @ 0.1% BER
Average Power Consumption	<10 uA for 1 second BLE connection interval

For full specifications on SaBLE-x-R2, please refer to datasheet.

TECHNICAL DETAILS

Bluetooth 5 Certified
Integrated ARM Cortex-M3 MCU, dedicated Cortex-M0 MCU for RF core, and dedicated Sensor Processor Engine
128 kB flash and 20 kB SRAM on-module memory

KEY FEATURES

Host or hostless mode operations
Highly-configurable I/O that supports all common peripherals (UART, SPI, I ² C, PWM, ADC, etc.)

ORDER INFORMATION

PART #	DESCRIPTION
450-0177C	SaBLE-x-R2 Module, PCB Trace Antenna (Cut Tape)
450-0177R	SaBLE-x-R2 Module, PCB Trace Antenna (Tape & Reel)
450-0178C	SaBLE-x-R2, External Antenna Port (Cut Tape)
450-0178R	SaBLE-x-R2, External Antenna Port (Tape & Reel)
450-0184	SaBLE-x Evaluation Kit with TI EM Adapter and Arduino Adapter
450-0185	SaBLE-x Evaluation Kit with External Antennas, TI EM Adapter and Arduino Adapter

These LSR products are all REACH and EU ROHS compliant.

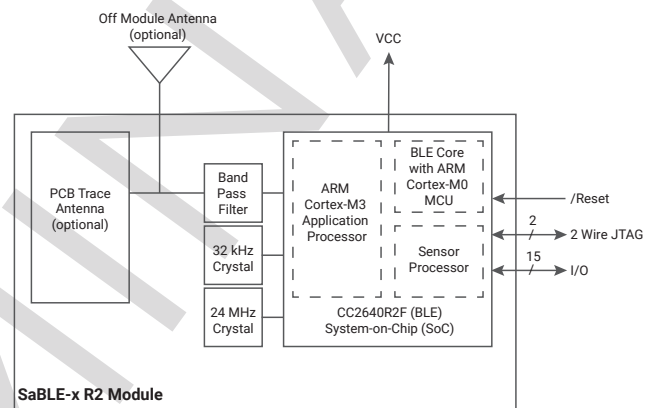

LSR is the leader in Wireless Product Development, offering true end-to-end solutions through its array of services and technical expertise.



Design Services

LSR delivers complete system solutions from concept to manufacturing. We are your wireless M2M solutions partner, providing complete turnkey services and solutions.

- RF Design/Engineering
- Software/Firmware Design
- Antenna Design
- Industrial Design
- Mechanical Engineering



EMC Testing & Certification

At LSR, we understand it is critical for your company to have a compliant product supported by the appropriate documentation, ready for deployment into the market. LSR provides the experience and knowledge to provide quality test services that meet your timeline and budget.

- On-Site FCC / IC /CE EMC Certification
- Wireless & Antenna Testing
- EMC Testing
- International Testing Services



Wireless Products

LSR offers the fastest, lowest cost way to add wireless capabilities to your product concept. LSR's fully-certified modules and antennas accelerate your time-to-market and support the full breadth of communication technologies, including:

- Wi-Fi®
- Bluetooth®
- Bluetooth® Low Energy
- ZigBee®
- 802.15.4 & proprietary protocols