

## DETAILS

<b>Product Number</b>	F14487_FLORENCE-1R-MAXI-WG
<b>Family</b>	Florence
<b>Type</b>	Lens
<b>Color</b>	clear
<b>Diameter</b>	21,65 x 286 mm
<b>Height</b>	11,04 mm
<b>Style</b>	rectang
<b>Optic Material</b>	PMMA
<b>Holder Material</b>	
<b>Fastening</b>	
<b>Status</b>	production ready
<b>ROHS Compliant</b>	Yes
<b>Date Updated</b>	13/01/2016

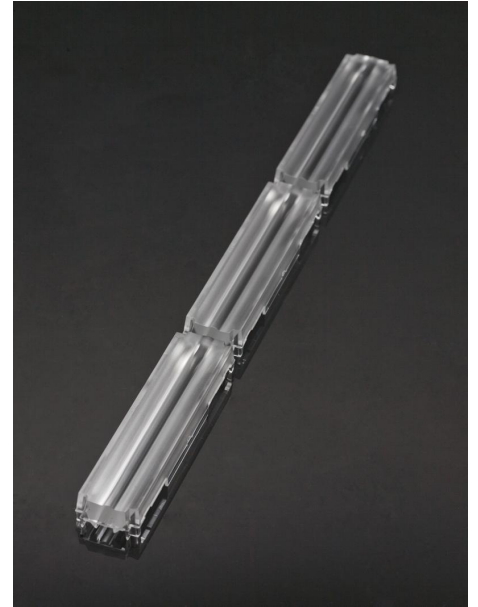

## OPTICAL PROPERTIES

LED	Viewing Angle	Light Beam	Efficiency	cd/lm	Connector
L0-280024-xxx-C0800-L267	asymmetric deg	Asymmetric	90 %	0.770	-
XP-G	Asymmetric deg	Asymmetric	92 %	1.400	-
XP-E2	asymmetric deg	Asymmetric	94 %	1.470	-
XP-E	Asymmetric deg	Asymmetric	91 %	1.700	-
XB-H	sim: Asymmetric	Asymmetric	sim: 90 %	sim: 0.000	-
XQ-E	asymmetric deg	Asymmetric	94 %	1.580	-
XP-G2	Asymmetric deg	Asymmetric	93 %	1.500	-
XQ-E HI	sim: Asymmetric	Asymmetric	sim: 91 %	sim: 2.460	-
LUXEON Rebel ES	Asymmetric deg	Asymmetric	92 %	1.300	-
LUXEON T	sim: Asymmetric	Asymmetric	sim: 90 %	sim: 0.000	-
LUXEON R	sim: Asymmetric	Asymmetric	sim: 88 %	sim: 0.000	-
LUXEON Rebel	Asymmetric deg	Asymmetric	92 %	1.400	-
LUXEON A	Asymmetric deg	Asymmetric	92 %	1.400	-
LUXEON Z ES	asymmetric deg	Asymmetric	94 %	1.300	-
LUXEON TX	sim: Asymmetric	Asymmetric	sim: 91 %	sim: 0.000	-
LUXEON 3030 2D	Asymmetric deg	Asymmetric	91 %	1.000	-
LUXEON 3014	Asymmetric deg	Asymmetric	93 %	1.500	-
NCSxx19B	Asymmetric deg	Asymmetric	91 %	1.300	-
NF2x757A	sim: Asymmetric	Asymmetric	sim: 89 %	sim: 0.000	-
NVSxx19B/NVSxx19C	Asymmetric deg	Asymmetric	91 %	1.200	-
NF2x757G	asymmetric deg	Asymmetric	90 %	1.040	-
Duris S5 (2 chip)	Asymmetric deg	Asymmetric	91 %	1.100	-
Oslon SSL 80	Asymmetric deg	Asymmetric	93 %	1.700	-
Fortimo LED Line 1ft 1100lm xx0 1R xv2	Asymmetric deg	Asymmetric	94 %	0.940	-
LT-S282N	Asymmetric deg	Asymmetric	94 %	1.200	-



# PRODUCT DATASHEET

## Florence series

last update 13/1/2016

### OPTICAL PROPERTIES

LED	Viewing Angle	Light Beam	Efficiency	cd/lm	Connector
LM301A	Asymmetric deg	Asymmetric	91 %	1.100	-
LM561C	asymmetric deg	Asymmetric	94 %	1.130	-
CALGD0414-M8W1	asymmetric deg	Asymmetric	92 %	1.050	-
CALGD0814-M17W1	asymmetric deg	Asymmetric	92 %	1.040	-

H G F E D C B A

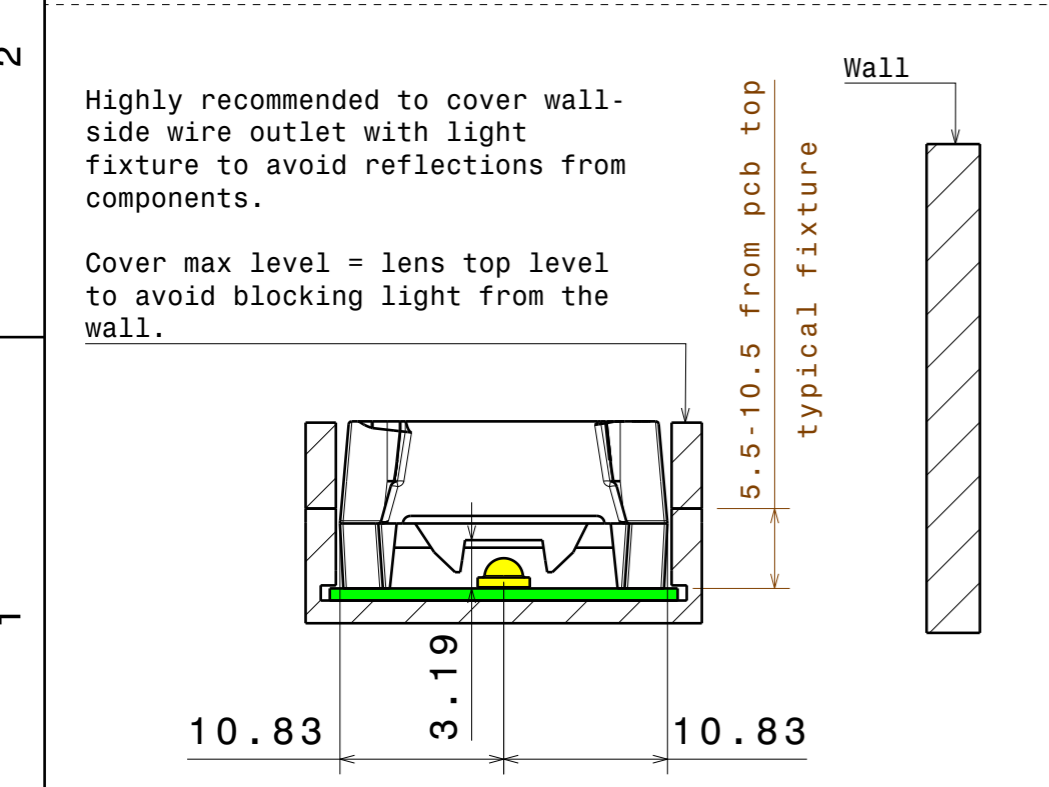
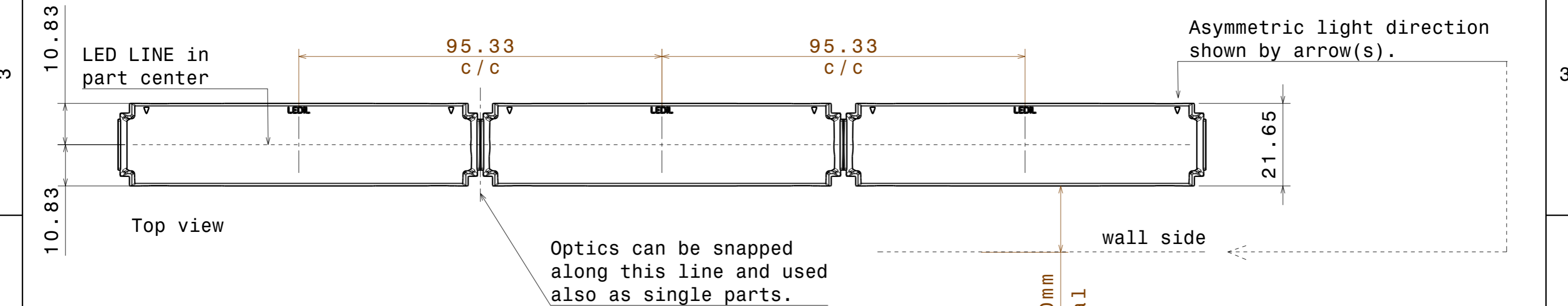
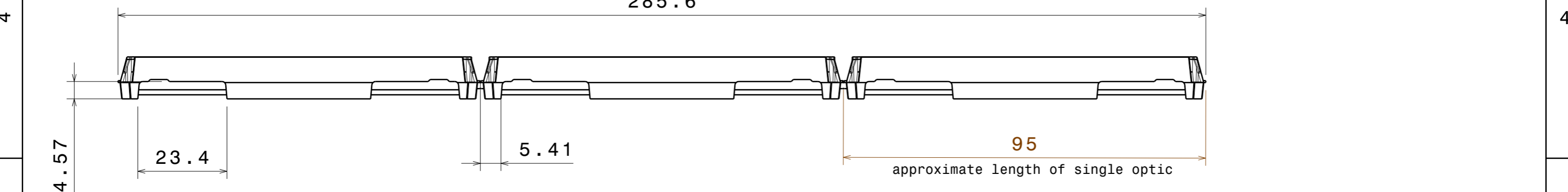

INDEX	PART NO	DESCRIPTION	MATERIAL	COLOUR
1	C14487	FLORENCE-1R-MAXI-WG	PMMA	clear

Tolerances if not otherwise shown  
 According to DIN ISO 2768-1  
 Linear measures: class M  
 According to DIN ISO 2768-2  
 Form and position: class L

**LEDiL** LediL Oy  
 Salorankatu 10  
 FIN 24240 SALO  
 Finland

THIRD ANGLE PROJECTION:

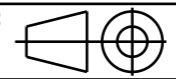

DRAWING TITLE  
**C14487\_FLORENCE-1R-MAXI-WG**

This drawing is the property of LEDiL Oy. It may not be reproduced, copied or communicated without a written agreement with LEDiL Oy.

SIZE PART NUMBER  
**A3 C14487**

SCALE 1:1 WEIGHT SHEET 1/1

H G B A

Luminaire: Ledil F14487\_FLORENCE-1R-MAXI-WG\_(CeZos)

Lamps: 1 x CeZos\_(L0-280024-xxx-C0800-L267)\_1346.29lm@250mA\_CCT=3000K\_P=8.5017W\_I=0.25A

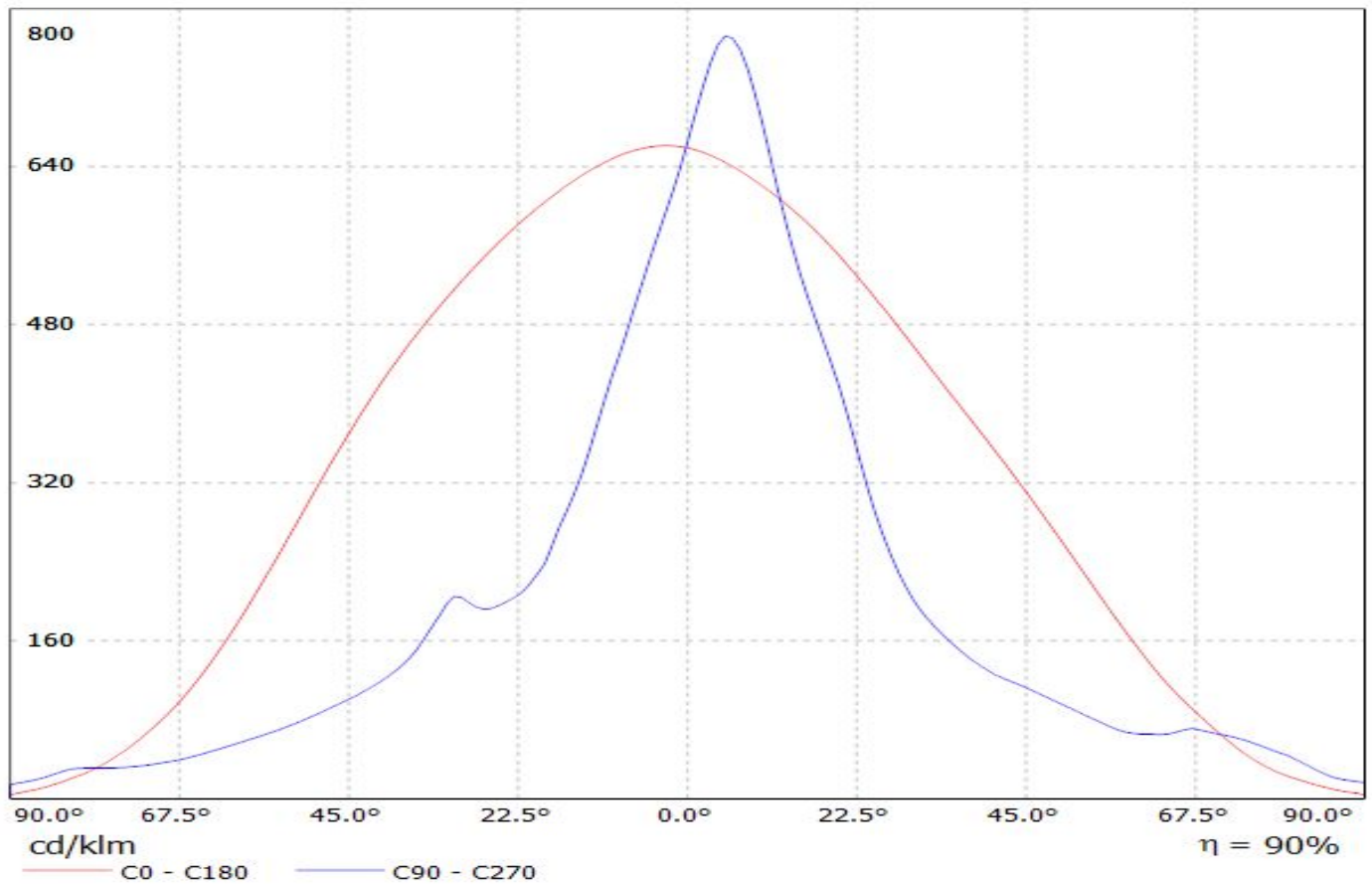

# Ledil F14487\_FLORENCE-1R-MAXI-WG\_(XP-G) / LDC (Linear)

Luminaire: Ledil F14487\_FLORENCE-1R-MAXI-WG\_(XP-G)

Lamps: 1 x Cree\_XP-G\_x12\_(XPGWHT-L1-CWPI-00BE7)\_795.108lm@250mA\_P=8.6W\_I=0.25A

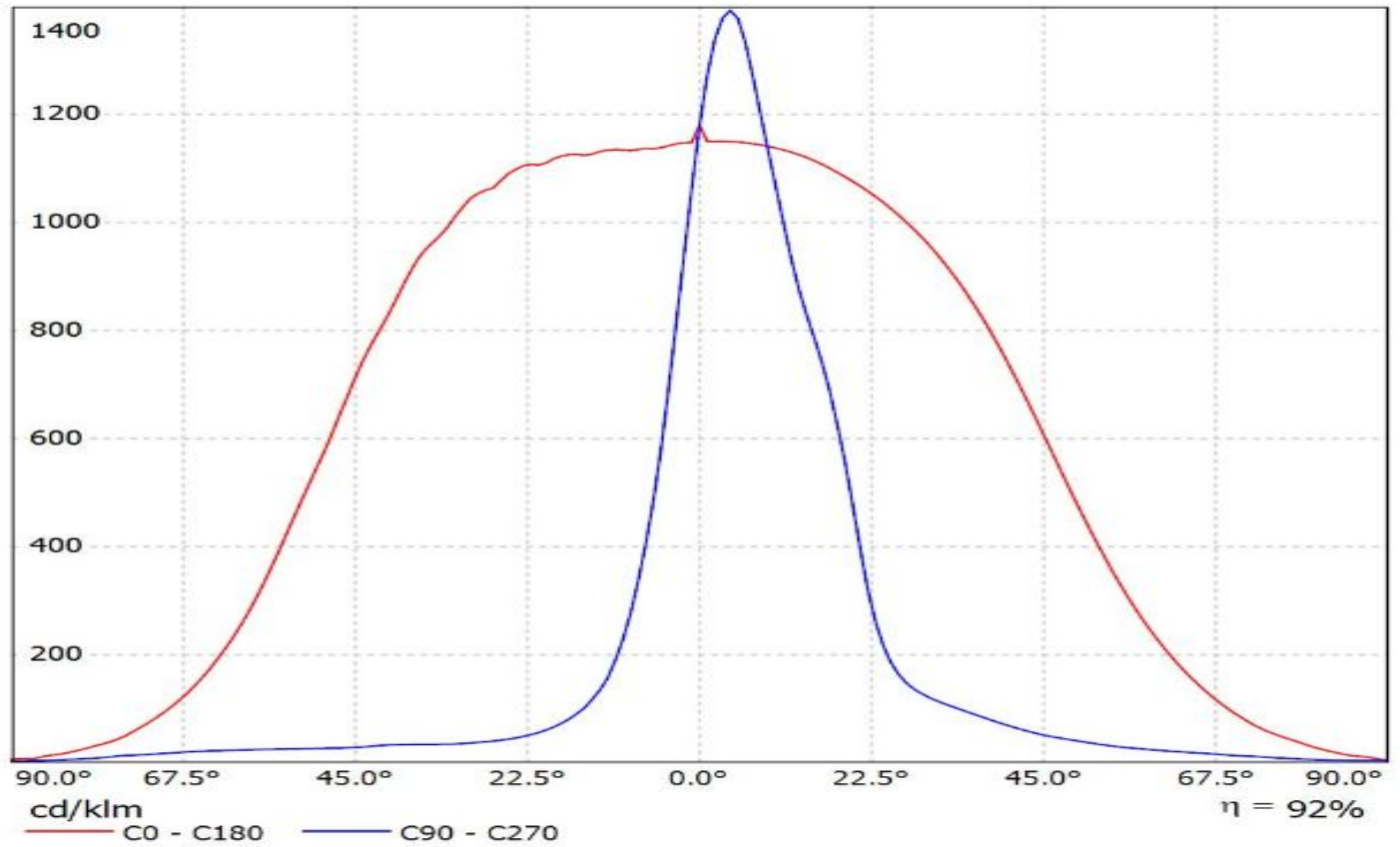

Luminaire: LEDiL Oy F14487\_FLORENCE-1R-MAXI-WG\_(XP-E2)\_2  
Lamps: 1 x (XP-E2\_florence)\_881.969lm@250mA\_P=8.62385W\_I=0.2498mA

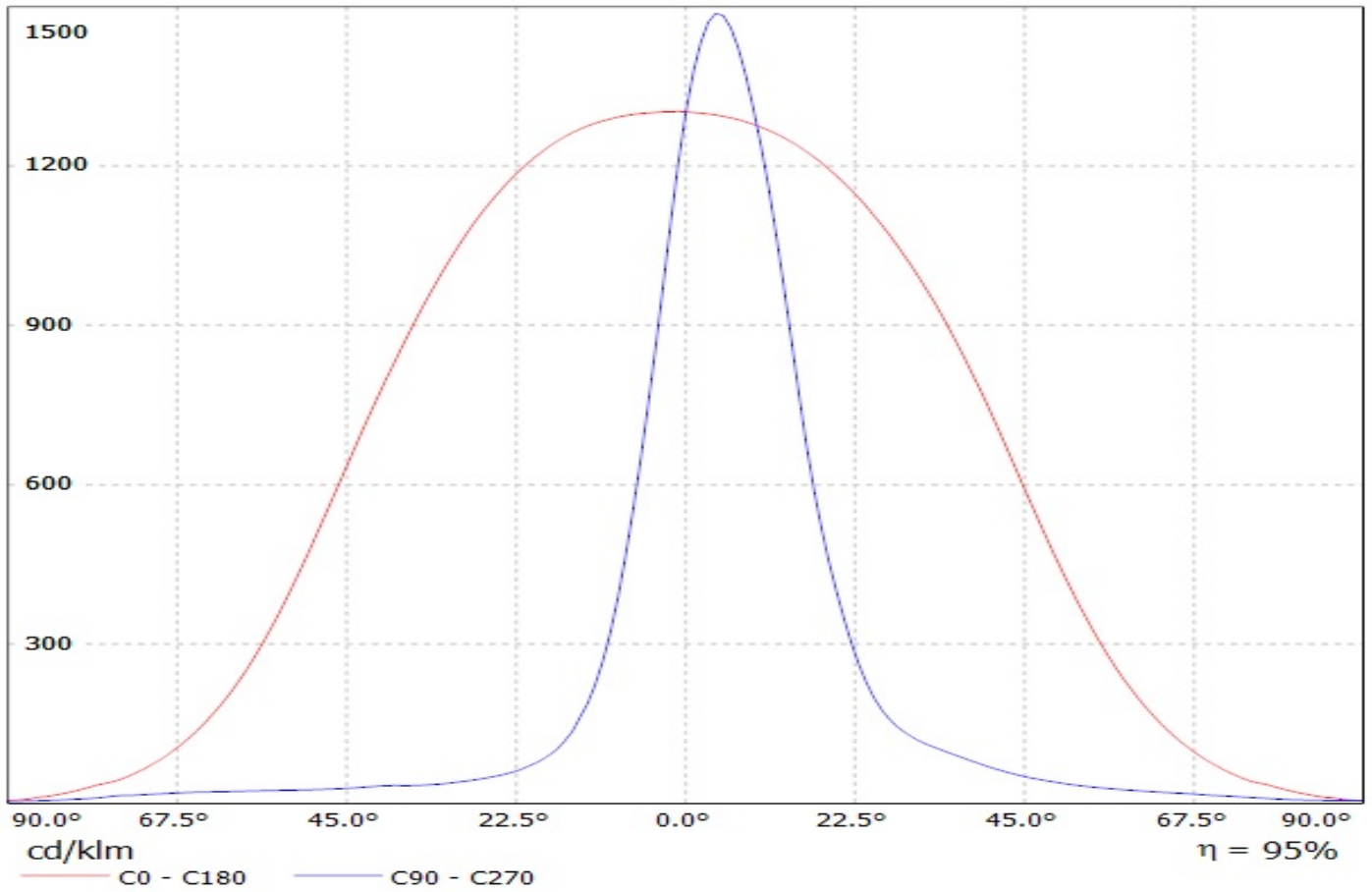

# Ledil F14487\_FLORENCE-1R-MAXI-WG\_(XP-E) / LDC (Linear)

Luminaire: Ledil F14487\_FLORENCE-1R-MAXI-WG\_(XP-E)

Lamps: 1 x Cree\_XP-E\_x12\_(XPEWHT-L1-3C0-Q5-0-06)\_941.258lm@250mA\_P=9W\_I=0.25A

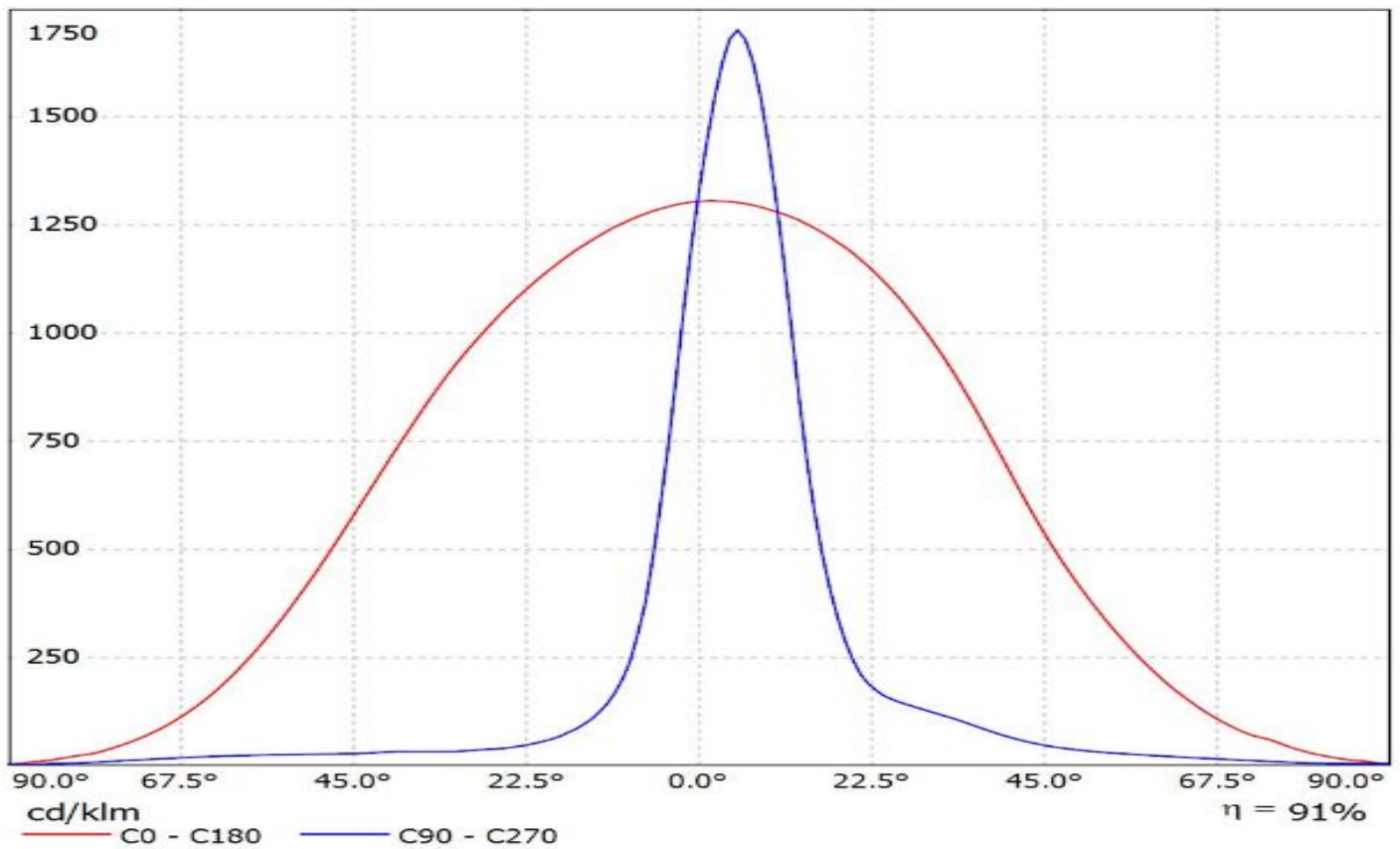

Luminaire: LEDiL Oy F14487\_FLORENCE-1R-MAXI-WG\_(XQ-E)

Lamps: 1 x CREE\_XQ-E\_(XQEAWT-0-7B1-Q40-0H-00001)\_872.003lm@250mA\_P=8.58163W\_I=249.8mA

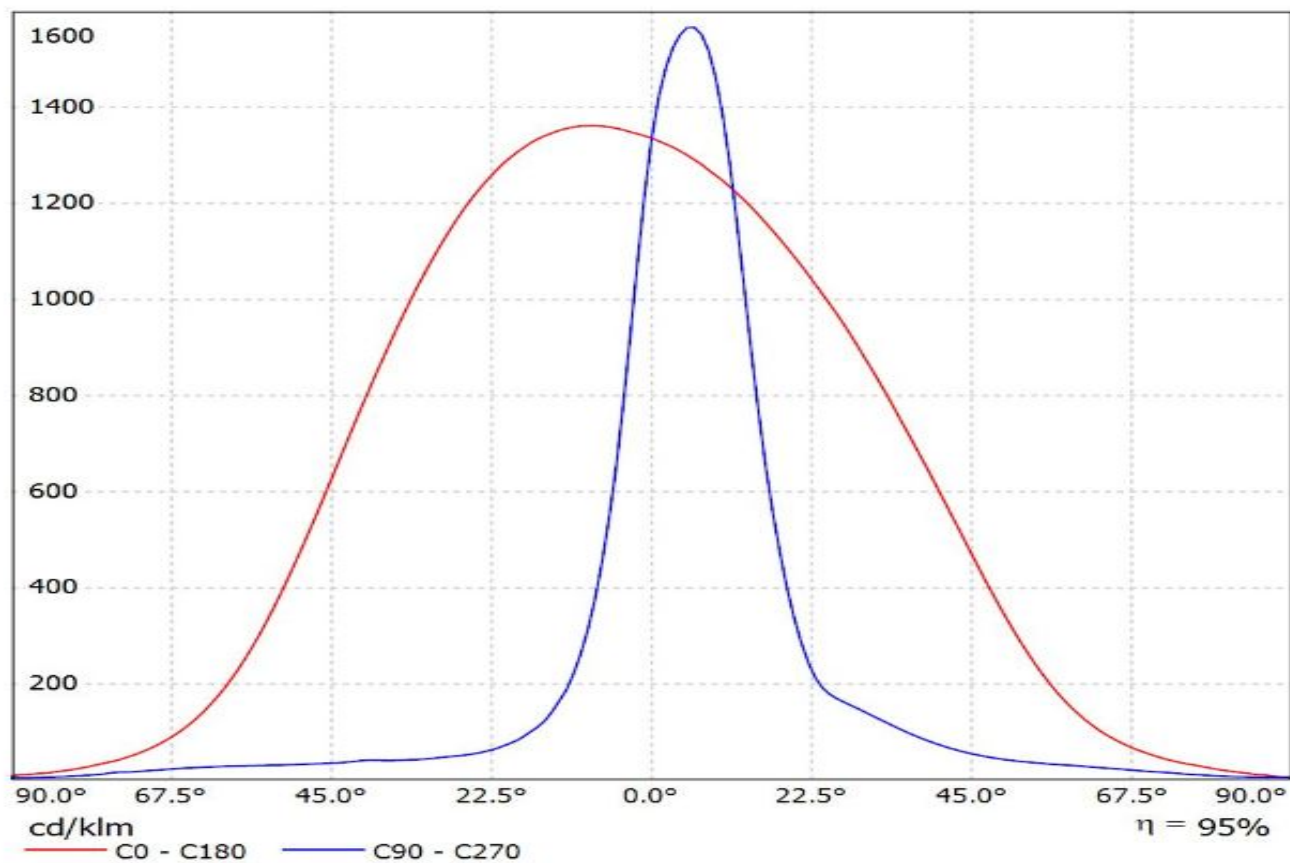

# Ledil F14487\_FLORENCE-1R-MAXI-WG\_(XP-G2) / LDC (Linear)

Luminaire: Ledil F14487\_FLORENCE-1R-MAXI-WG\_(XP-G2)

Lamps: 1 x Cree\_XP-G2\_x12\_(XPGBWT-01-4A0-R3-0-01)\_1206.16lm@250mA\_P=8.5W\_I=0.25A

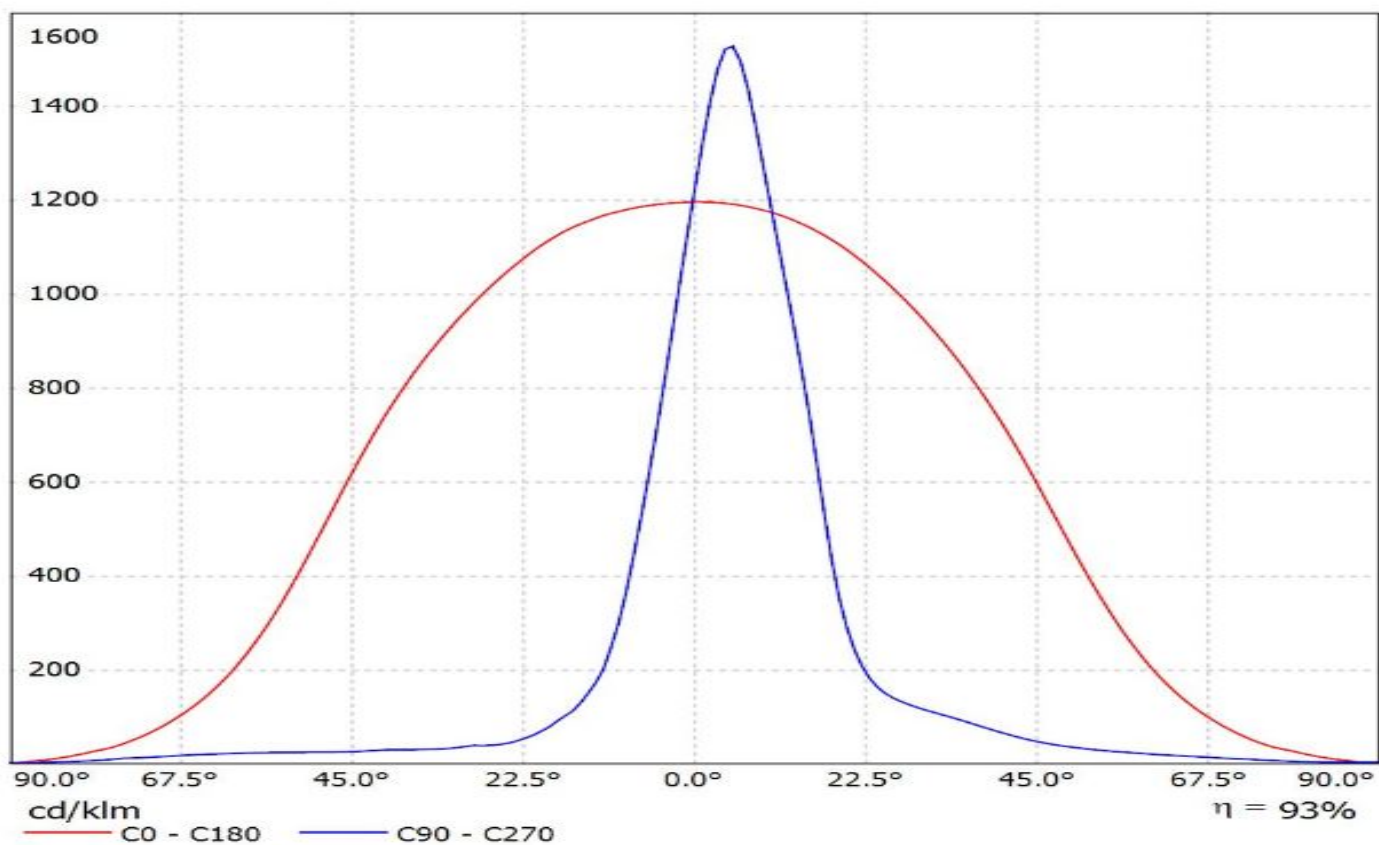

# Ledil F14487\_FLORENCE-1R-MAXI-WG\_(Rebel-ES) / LDC (Linear)

Luminaire: Ledil F14487\_FLORENCE-1R-MAXI-WG\_(Rebel-ES)

Lamps: 1 x Luxeon\_Rebel-ES\_x12\_(LXML-PWC2)\_1141.53lm@250mA\_P=8.65W\_I=0.25A

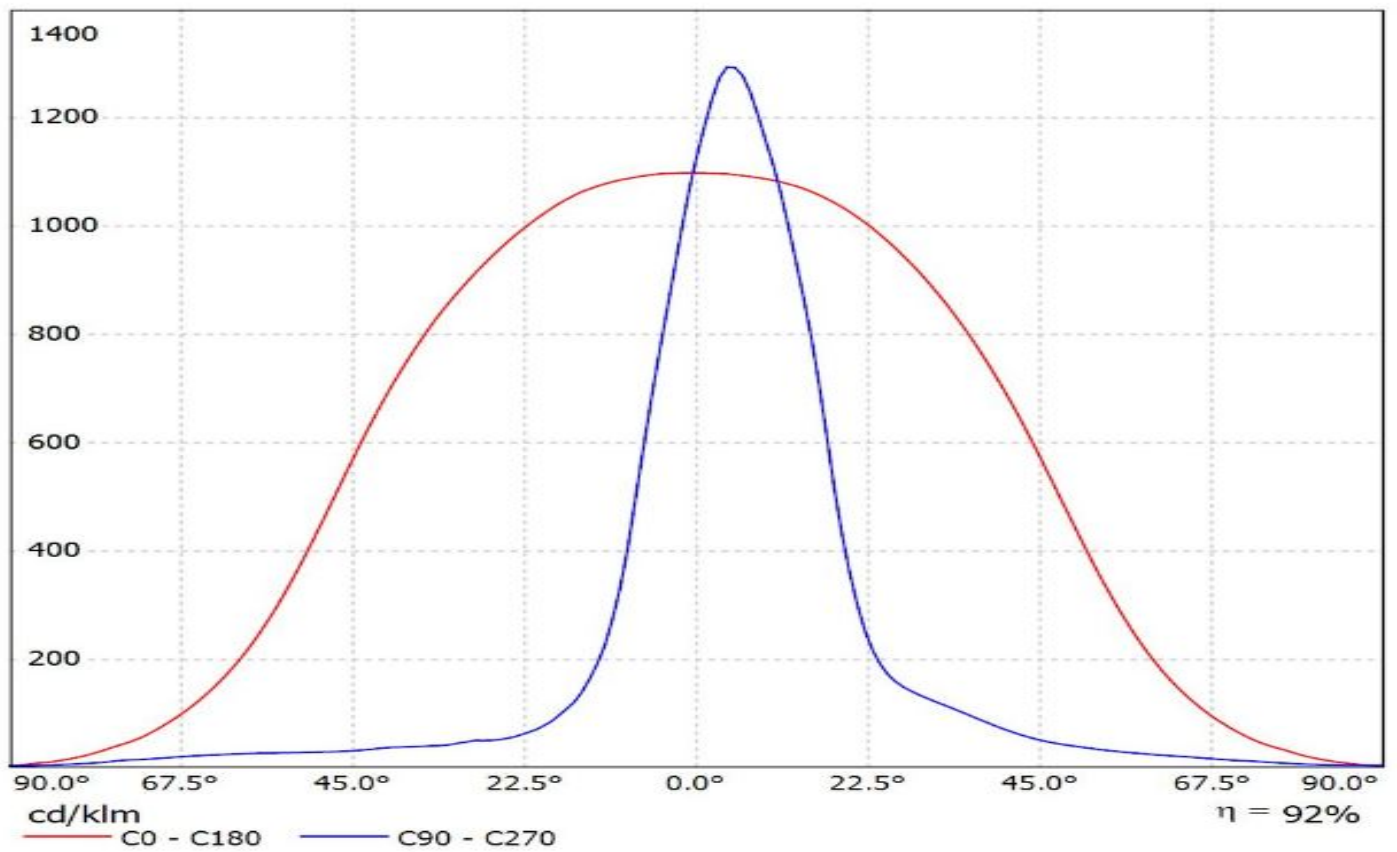

## Ledil F14487\_FLORENCE-1R-MAXI-WG\_(Rebel) / LDC (Linear)

Luminaire: Ledil F14487\_FLORENCE-1R-MAXI-WG\_(Rebel)

Lamps: 1 x Luxeon\_Rebel\_x12\_(LXM8-PW30)\_763.184lm@250mA\_P=8.3W\_I=0.25A

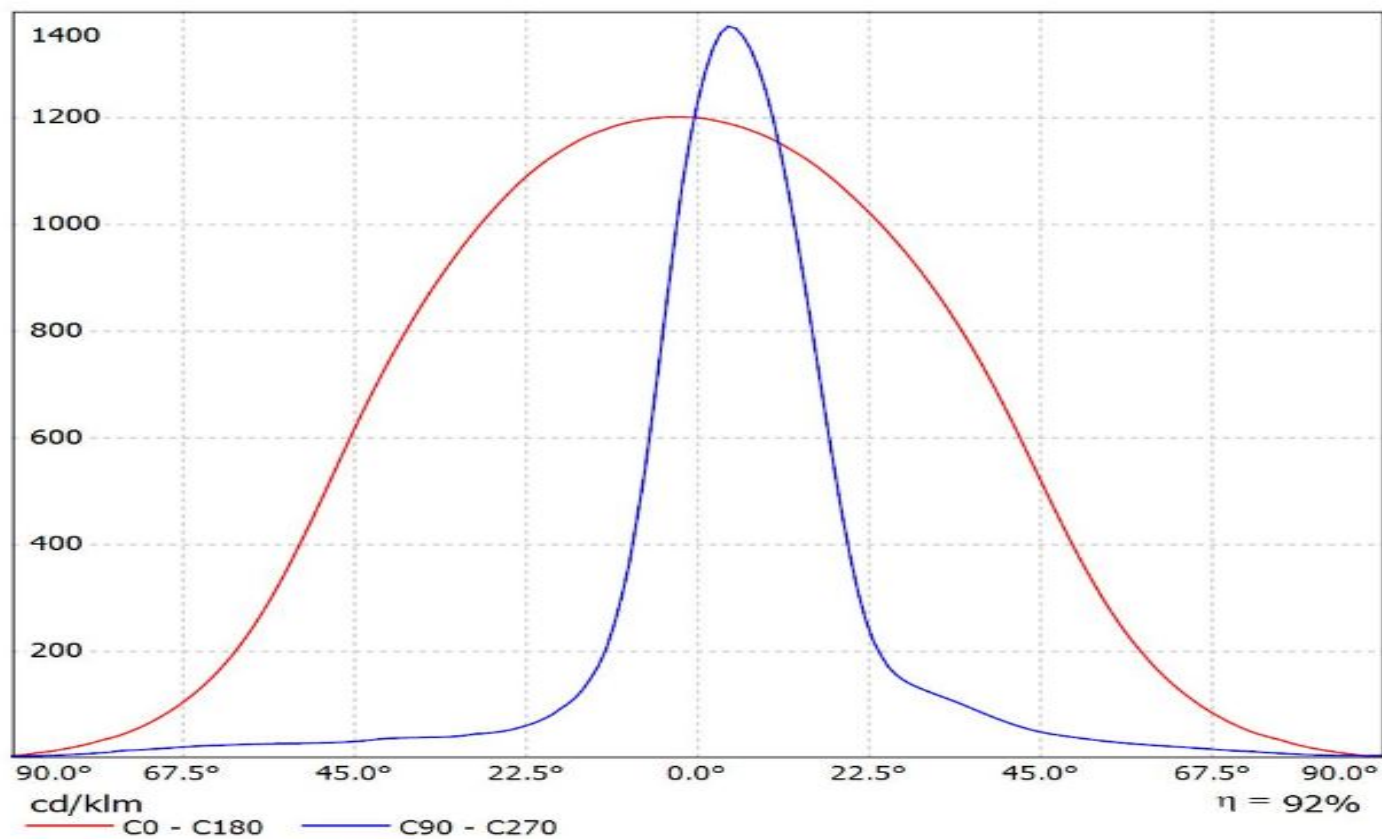

# Ledil F14487\_FLORENCE-1R-MAXI-WG\_(Luxeon\_A) / LDC (Linear)

Luminaire: Ledil F14487\_FLORENCE-1R-MAXI-WG\_(Luxeon\_A)  
Lamps: 1 x Luxeon\_A\_x12\_(LXH8-PW30)\_834.791lm@250mA\_P=8.3W\_I=0.25A

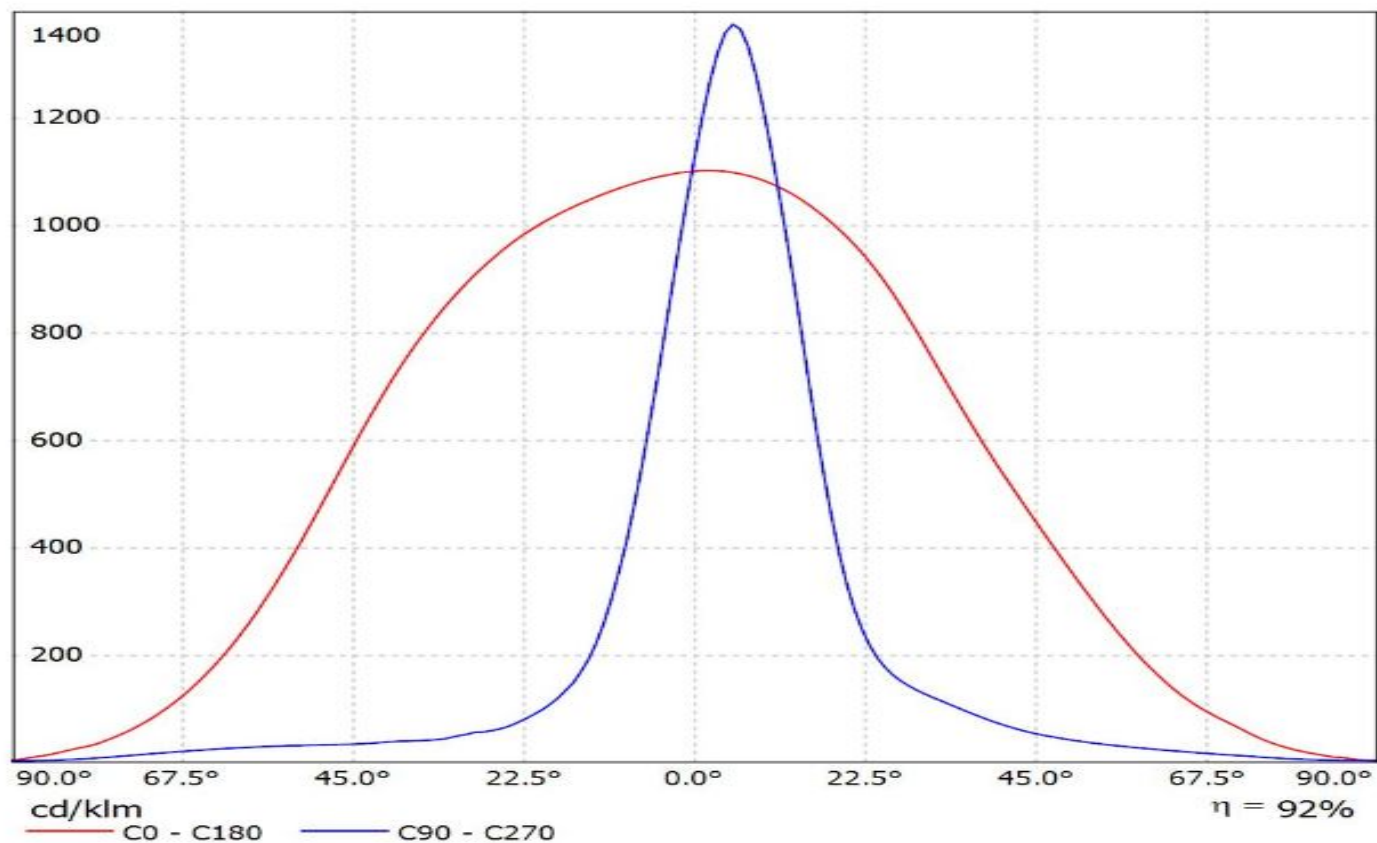

Luminaire: LEDiL Oy F14487\_FLORENCE-1R-MAXI-WG\_(LUXEON\_Z-ES)

Lamps: 1 x LUXEON\_Z-ES\_(LXZ2-3080-3)\_882.543lm@250mA\_CCT=3000K\_P=8.27363W\_I=249.8mA

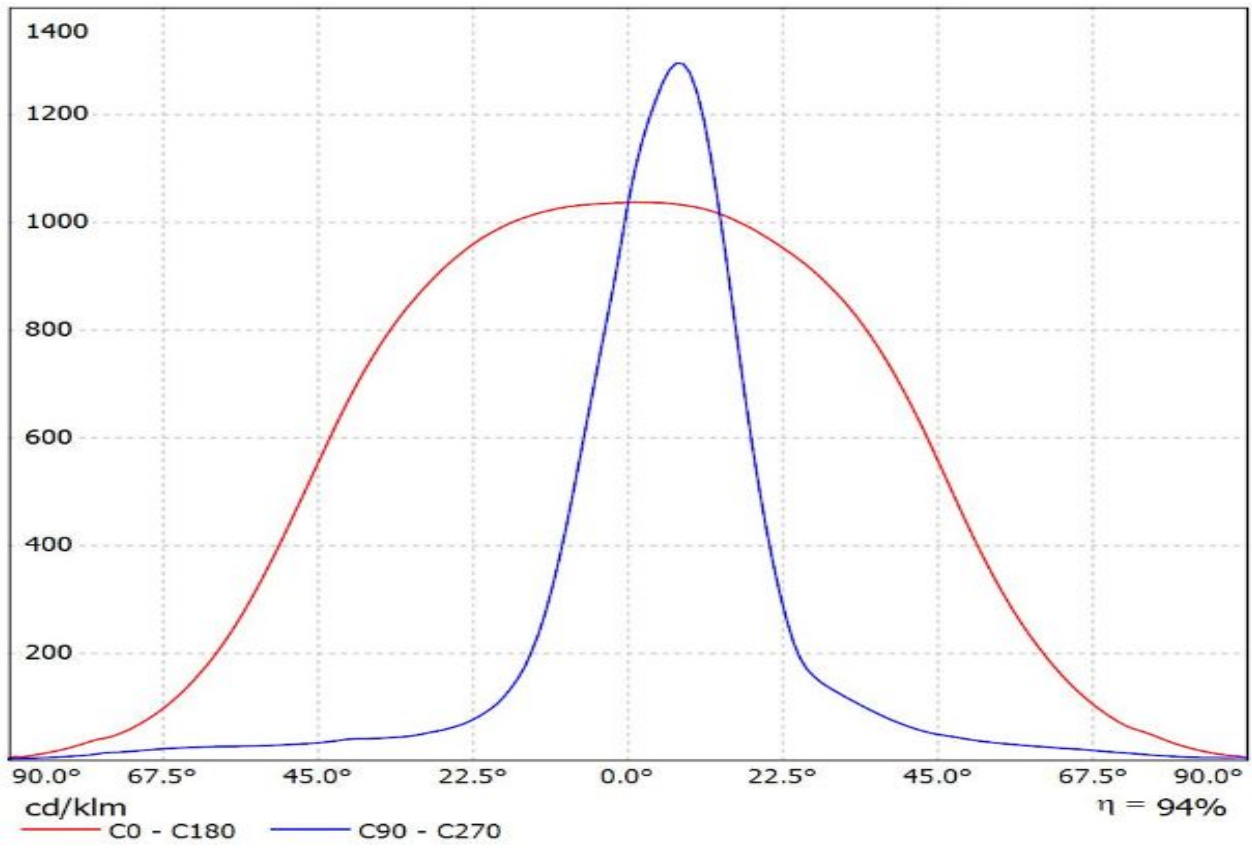

**Ledil F14487\_FLORENCE-1R-MAXI-WG\_(Luxeon\_3030\_2D) / LDC (Linear)**

Luminaire: Ledil F14487\_FLORENCE-1R-MAXI-WG\_(Luxeon\_3030\_2D)  
Lamps: 1 x Luxeon\_3030\_2D\_x22\_(L130-4080003000W21)  
\_1602.96lm@200mA\_CCT=4000K\_P=12.8W\_I=0.2A

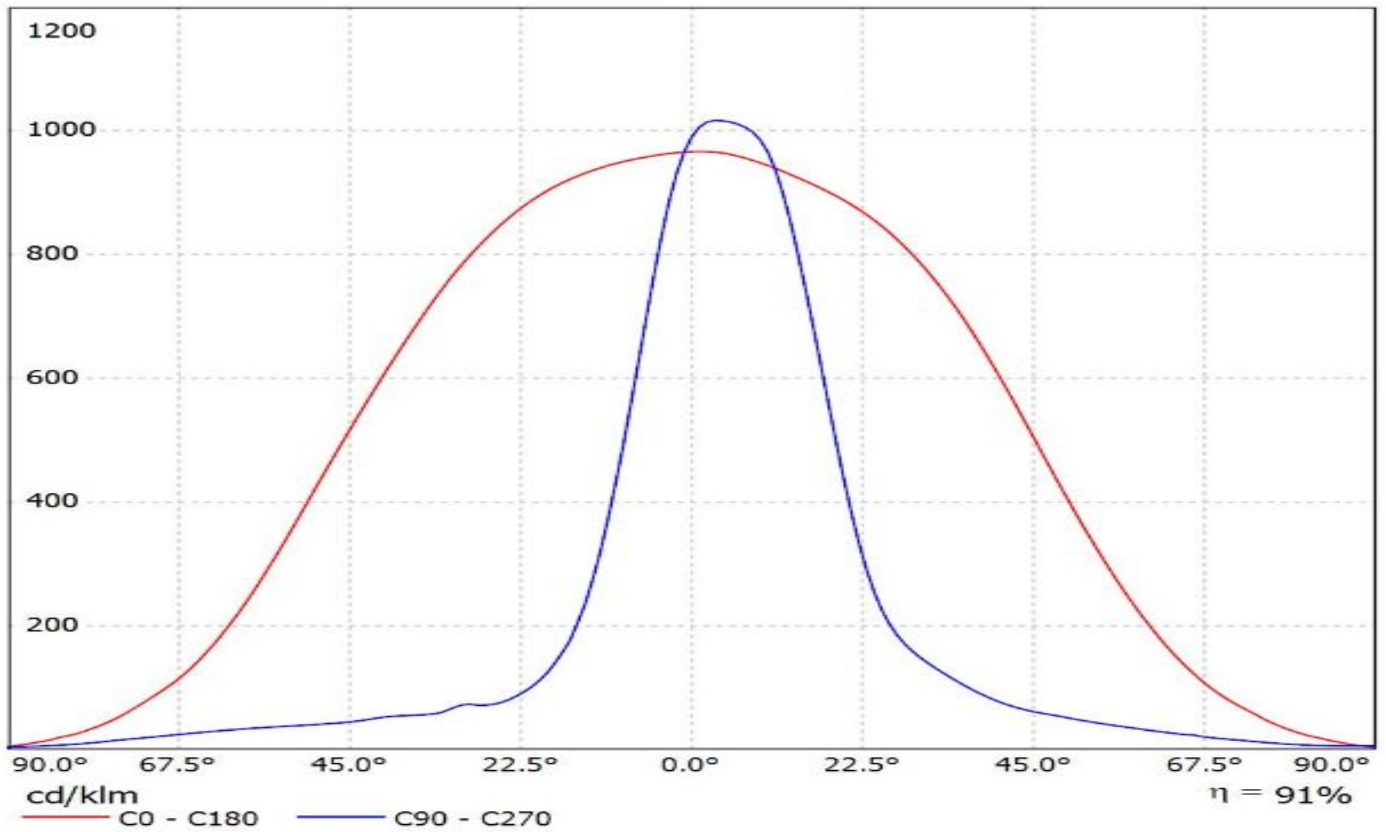

Luminaire: Ledil F14487\_FLORENCE-1R-MAXI-WG\_(3014\_x22)

Lamps: 1 x Luxeon\_3014\_x22\_(L130-5080)\_283.51lm@60mA\_P=1.9087W\_I=0.060mA

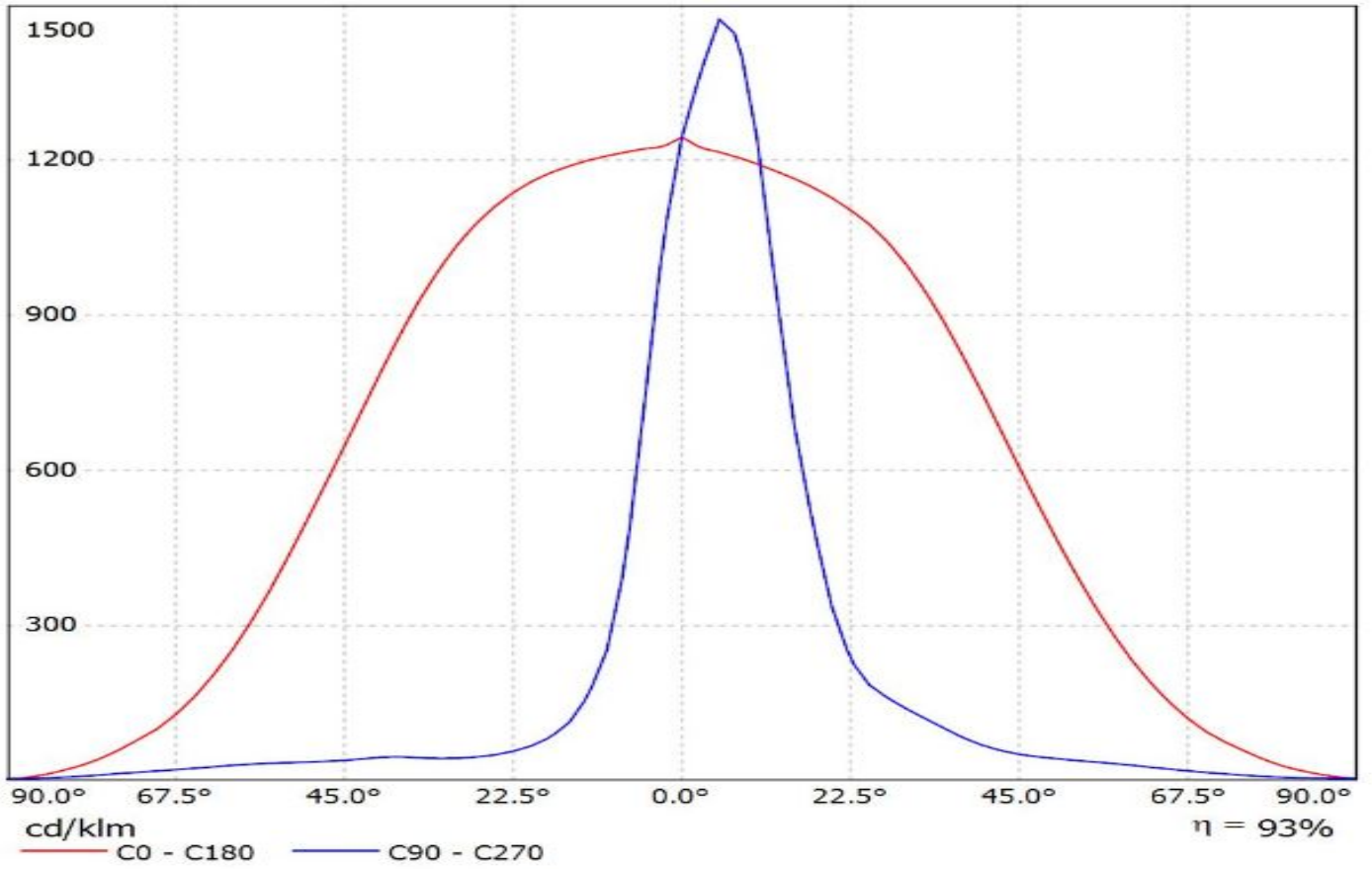

# Ledil F14487\_FLORENCE-1R-MAXI-WG\_(NCSxx19B) / LDC (Linear)

Luminaire: Ledil F14487\_FLORENCE-1R-MAXI-WG\_(NCSxx19B)

Lamps: 1 x Nichia\_NCSxx19B\_x12\_(NCSL219B)\_941.258lm@250mA\_P=8.9W\_I=0.25A

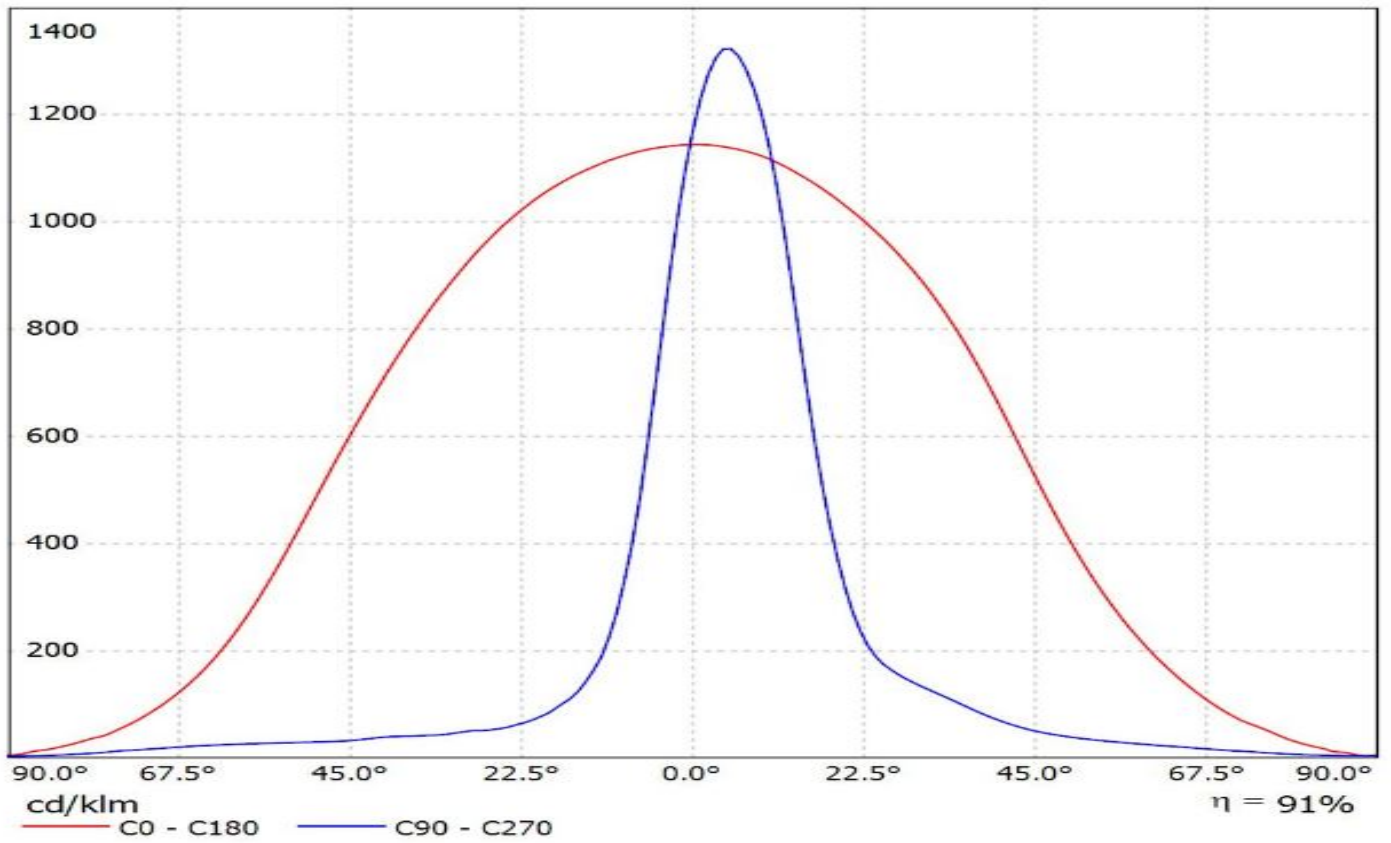

# Ledil F14487\_FLORENCE-1R-MAXI-WG\_(NVSxx19B) / LDC (Linear)

Luminaire: Ledil F14487\_FLORENCE-1R-MAXI-WG\_(NVSxx19B)

Lamps: 1 x Nichia\_NVSxx19B\_x12\_(NVSL219B)\_1045.07lm@250mA\_P=8.6W\_I=0.25A

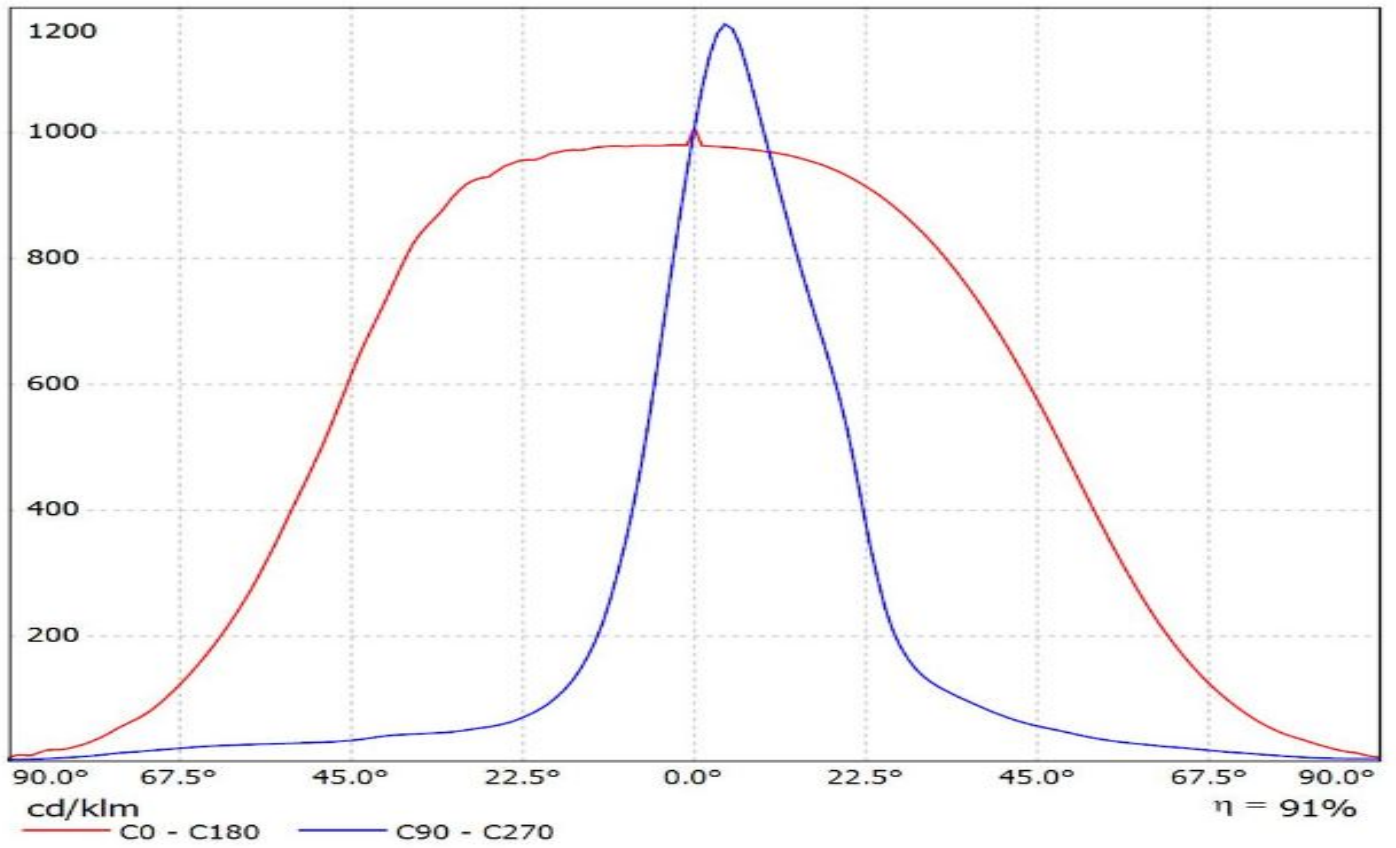

Luminaire: Ledil F14487\_FLORENCE-1R-MAXI-WG\_(NF2W757G)  
Lamps: 1 x NF2W757G\_378.284lm@65mA\_CCT=?K\_P=1.97W\_η=0.065A

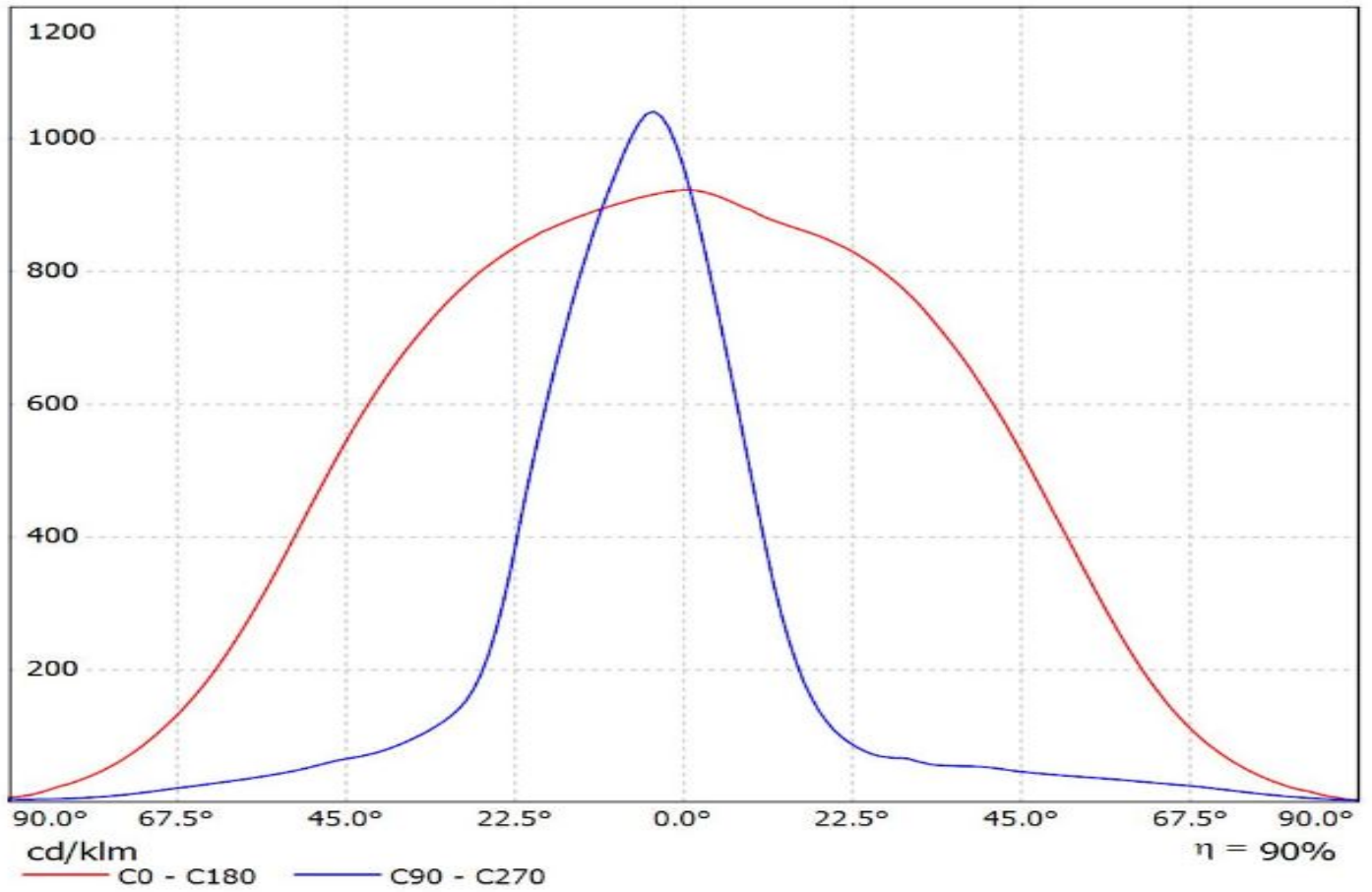

# Ledil F14487\_FLORENCE-1R-MAXI-WG\_(Duris\_S5-2chip) / LDC (Linear)

Luminaire: Ledil F14487\_FLORENCE-1R-MAXI-WG\_(Duris\_S5-2chip)

Lamps: 1 x Osram\_Duris\_S5-2chip\_x22\_1225.67lm@150mA\_P=9.55W\_I=150mA

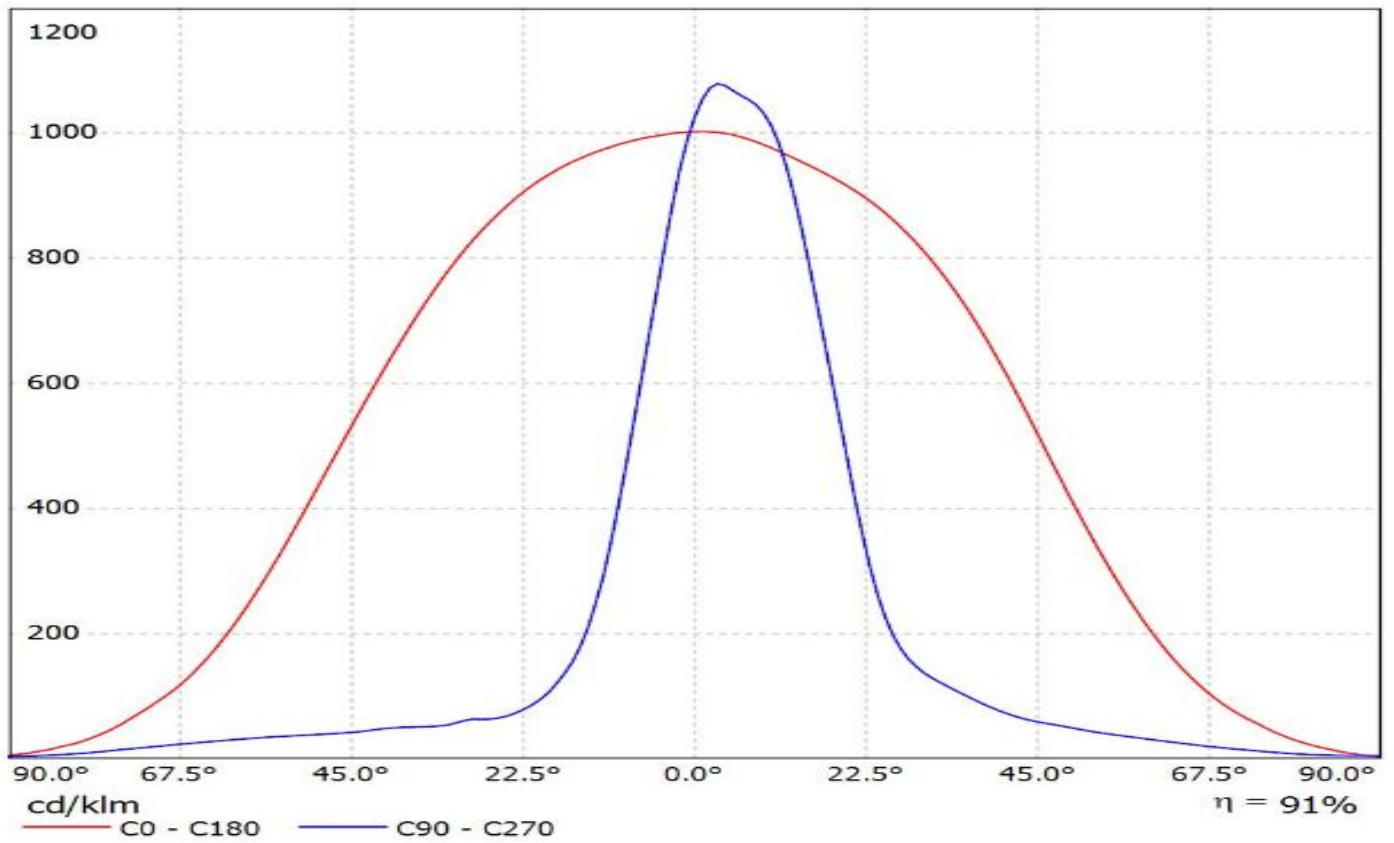

# Ledil F14487\_FLORENCE-1R-MAXI-WG\_(SSL80) / LDC (Linear)

Luminaire: Ledil F14487\_FLORENCE-1R-MAXI-WG\_(SSL80)

Lamps: 1 x Osram\_Oslon\_SSL80\_x12\_(LCW\_CQ7P.EC)\_838.967lm@250mA\_P=9.3W\_I=0.25A

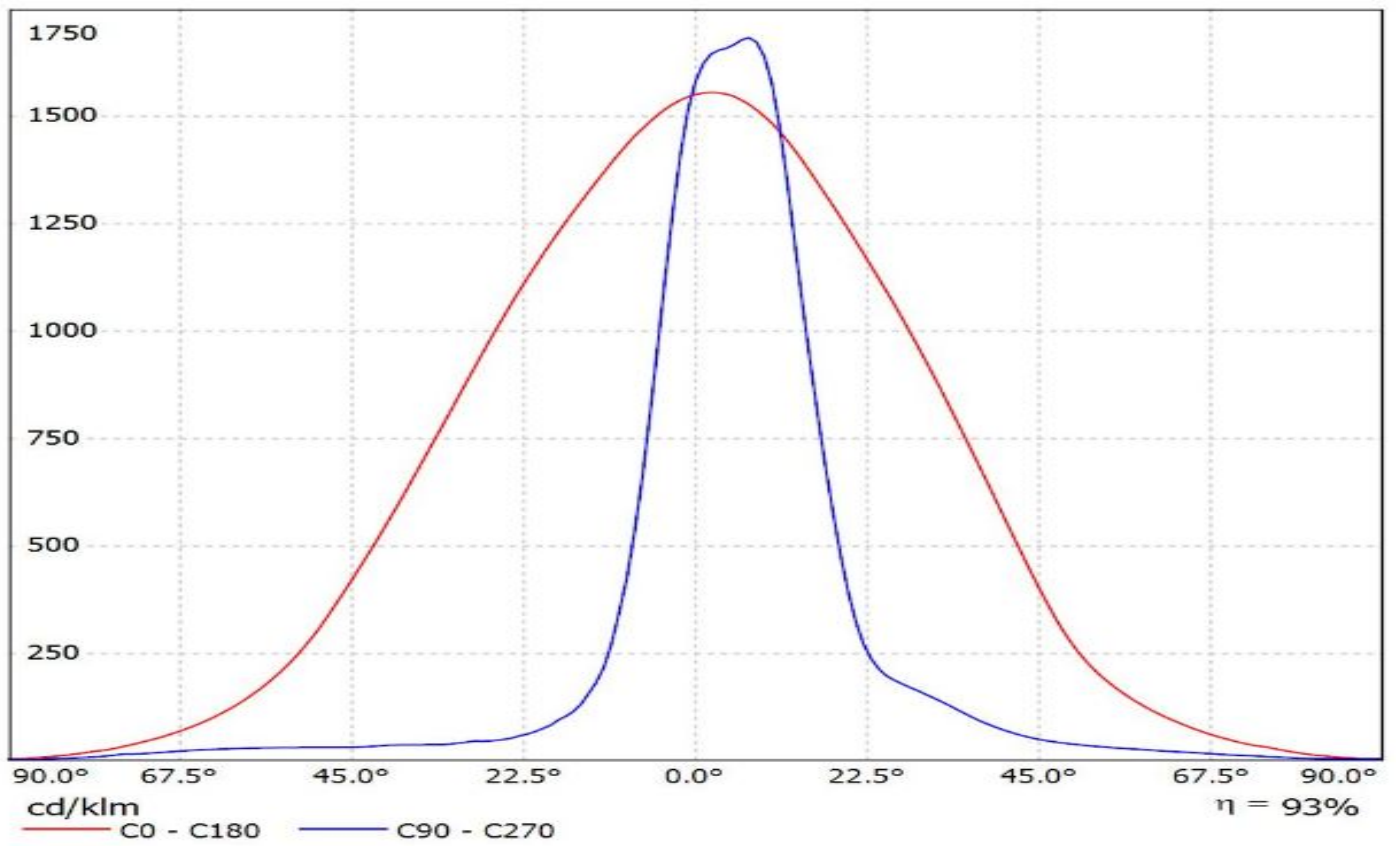

Luminaire: LEDiL Oy F14487\_FLORENCE-1R-MAXI-WG\_(Fortimo\_LED\_line\_1ft\_1100lm\_840\_1R\_LV2)  
Lamps: 1 x Philips\_Fortimo\_LED\_line\_1ft\_1100lm\_840\_1R\_LV2\_1067.99lm@250mA\_P=8.04281W\_I=0.2498mA

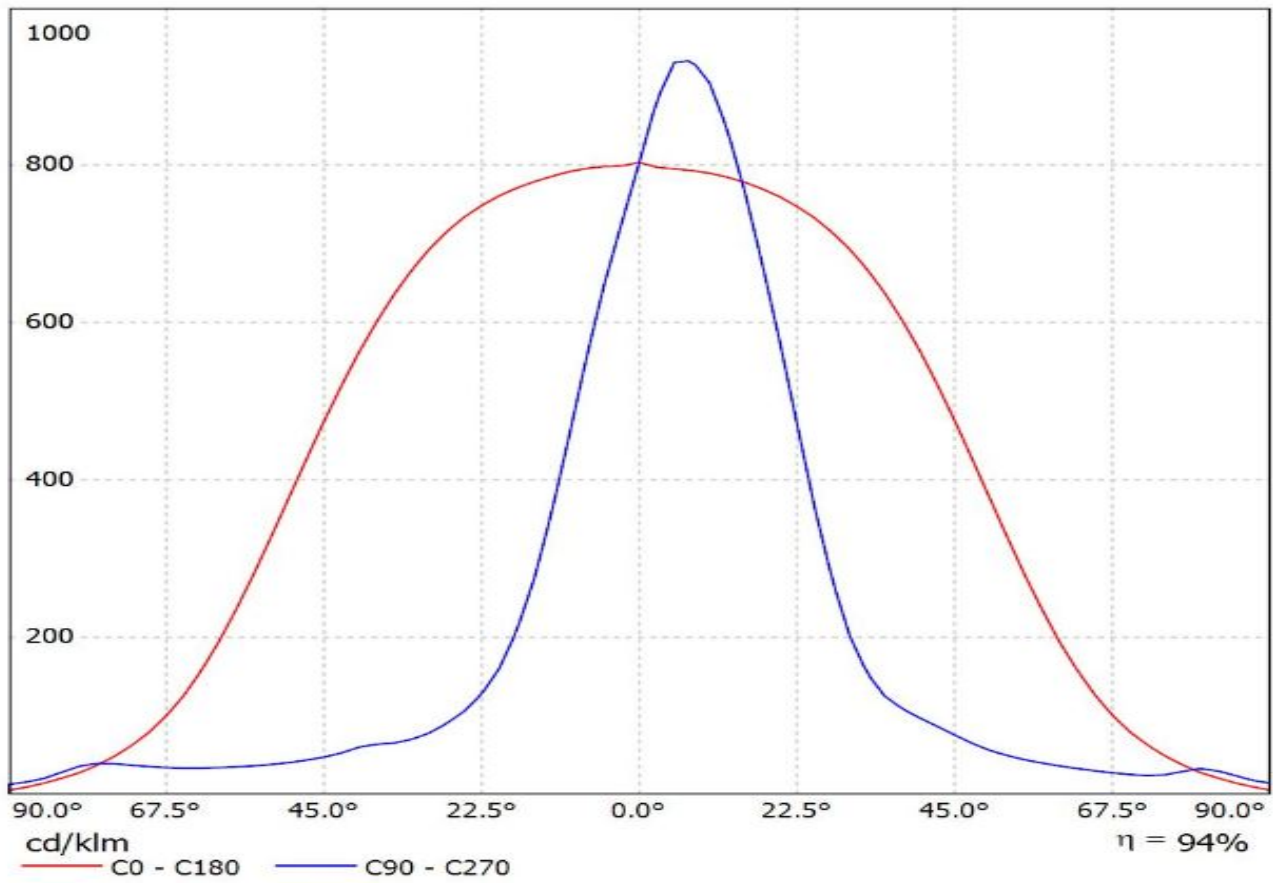

Luminaire: Ledil F14487\_FLORENCE-1R-MAXI-WG\_(LT-S282N)

Lamps: 1 x Samsung SI-B8T071280LD\_LM5618+\_1401.55lm@250mA\_P=9.185W\_I=0.25A

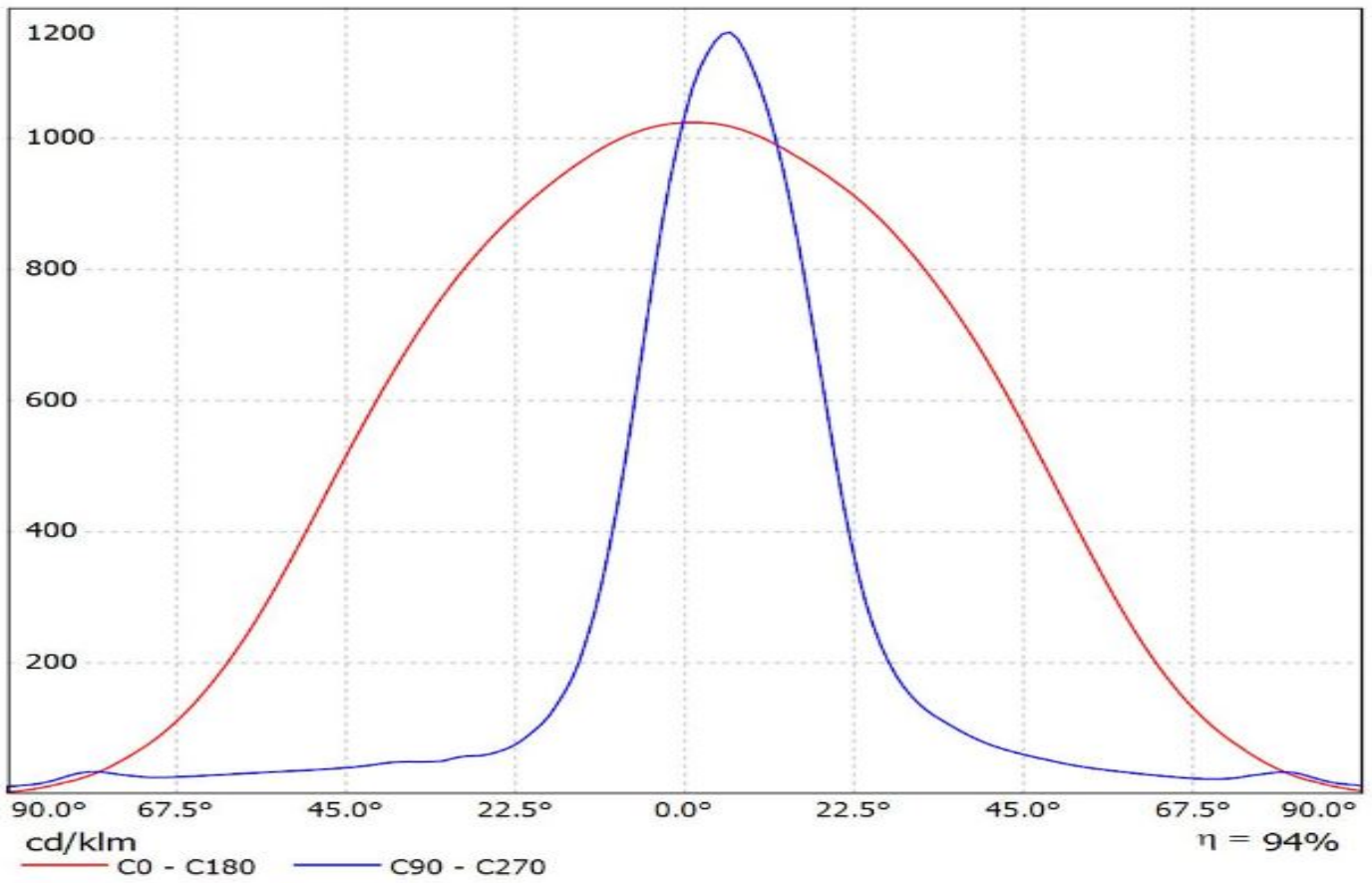

Luminaire: Ledil F14487\_FLORENCE-1R-MAXI-WG\_(LM301A)

Lamps: 1 x Samsung\_LM301A\_x11\_(SPMWHT328FD5WAT0S0)\_1107.77lm@250mA\_P=8.1W\_I=0.25A

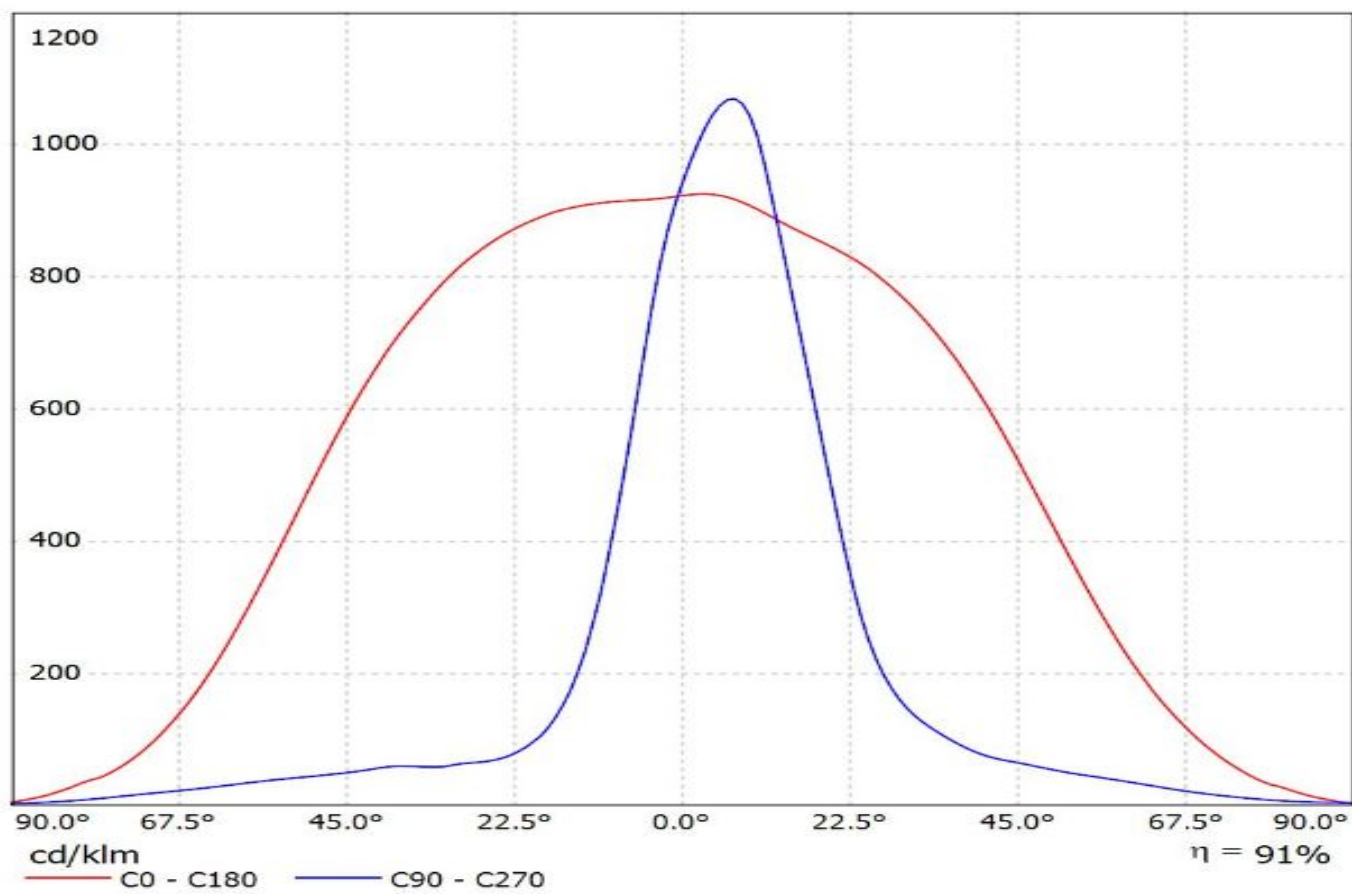

Luminaire: LEDiL Oy F14487\_FLORENCE-1R-MAXI-WG\_(LM561C)  
Lamps: 1 x Samsung\_LM561C\_685.154lm@130mA\_P=3.9367W\_I=0.130A

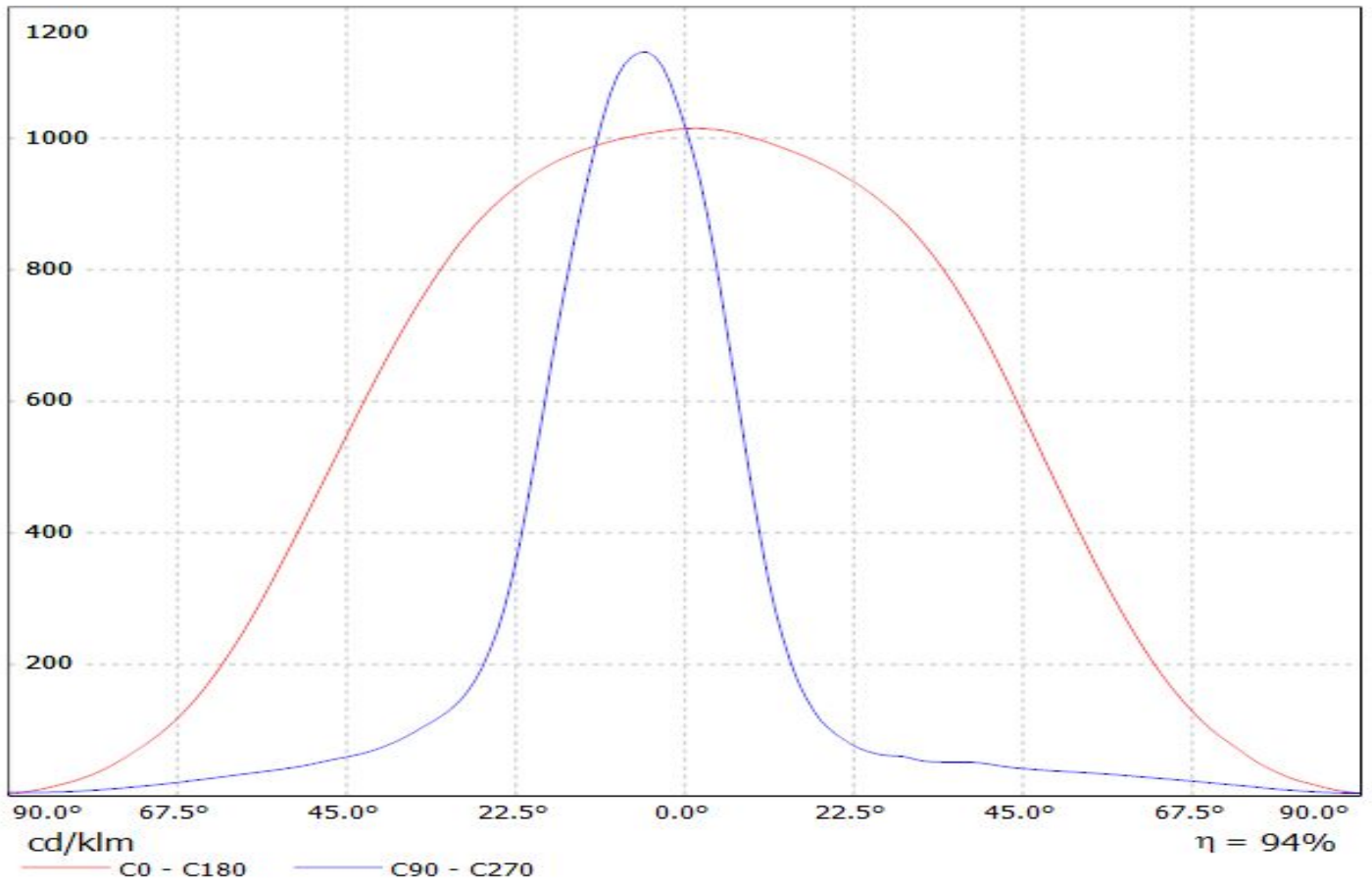

Luminaire: Ledil F14487\_FLORENCE-1R-MAXI-WG\_(CALGD0414-M8W1)  
Lamps: 1 x Citizen\_(CALGD0414-M8W1)\_556.672lm@350mA\_P=4.0291W\_I=0.3499A

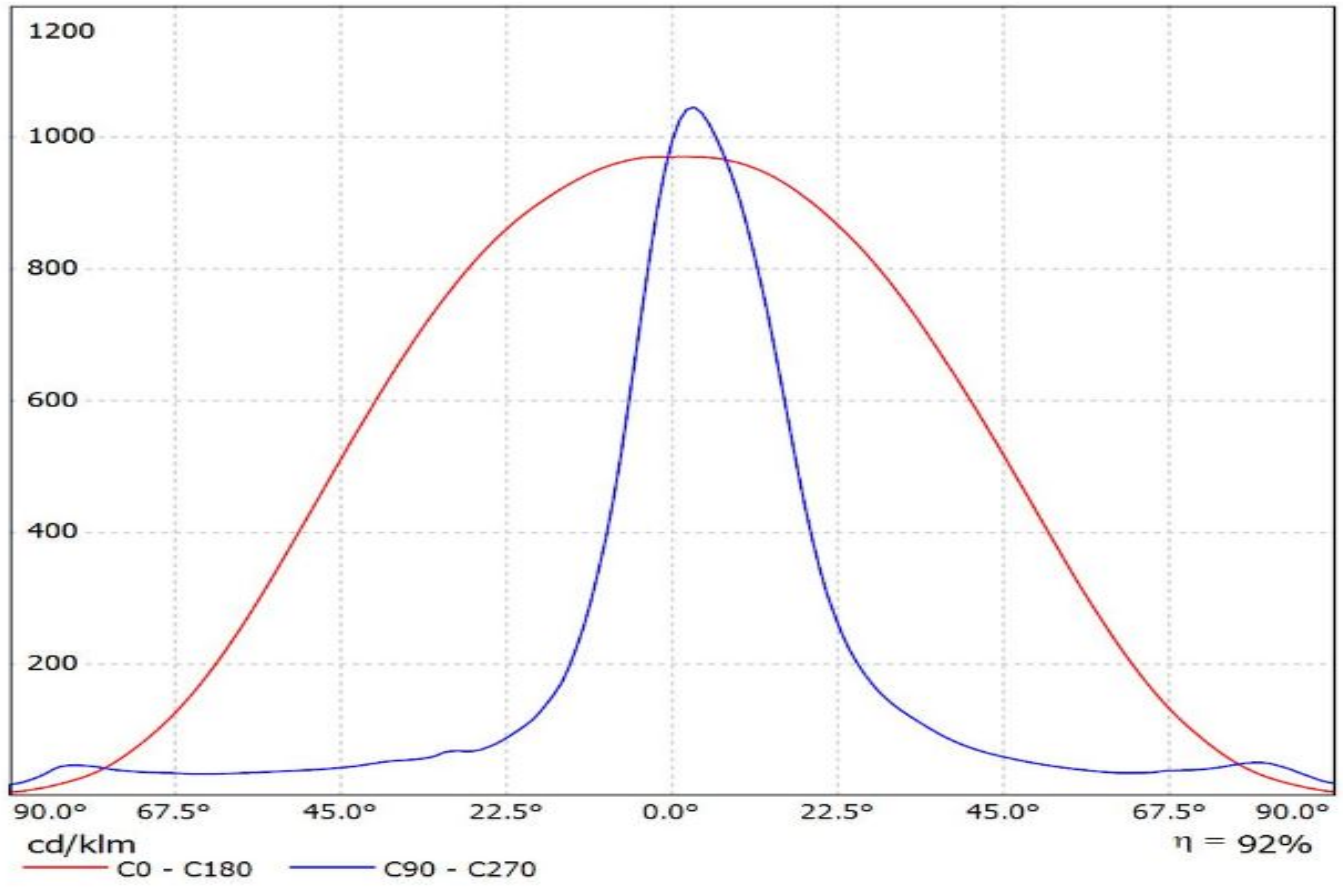

Luminaire: Ledil F14487\_FLORENCE-1R-MAXI-WG\_(CALGD0814-M17W1)  
Lamps: 1 x CALGD0814-M17W1\_1094.82lm@350mA\_P=7.9555W\_I=0.35A

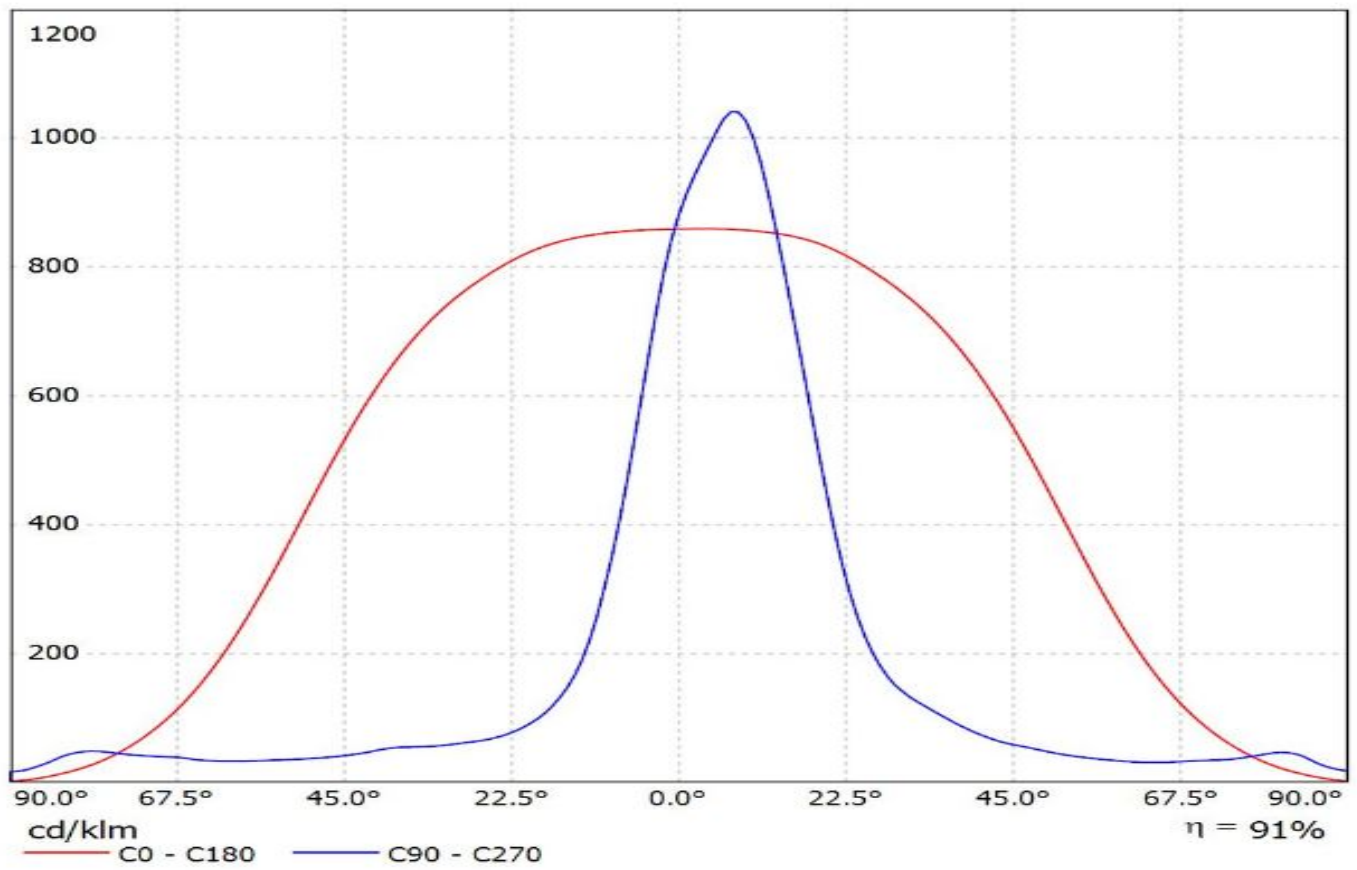

Luminaire: Ledil F14487\_FLORENCE-1R-MAXI-WG\_(CeZos)

Lamps: 1 x CeZos\_(L0-280024-xxx-C0800-L267)\_1346.29lm@250mA\_CCT=3000K\_P=8.5017W\_I=0.25A

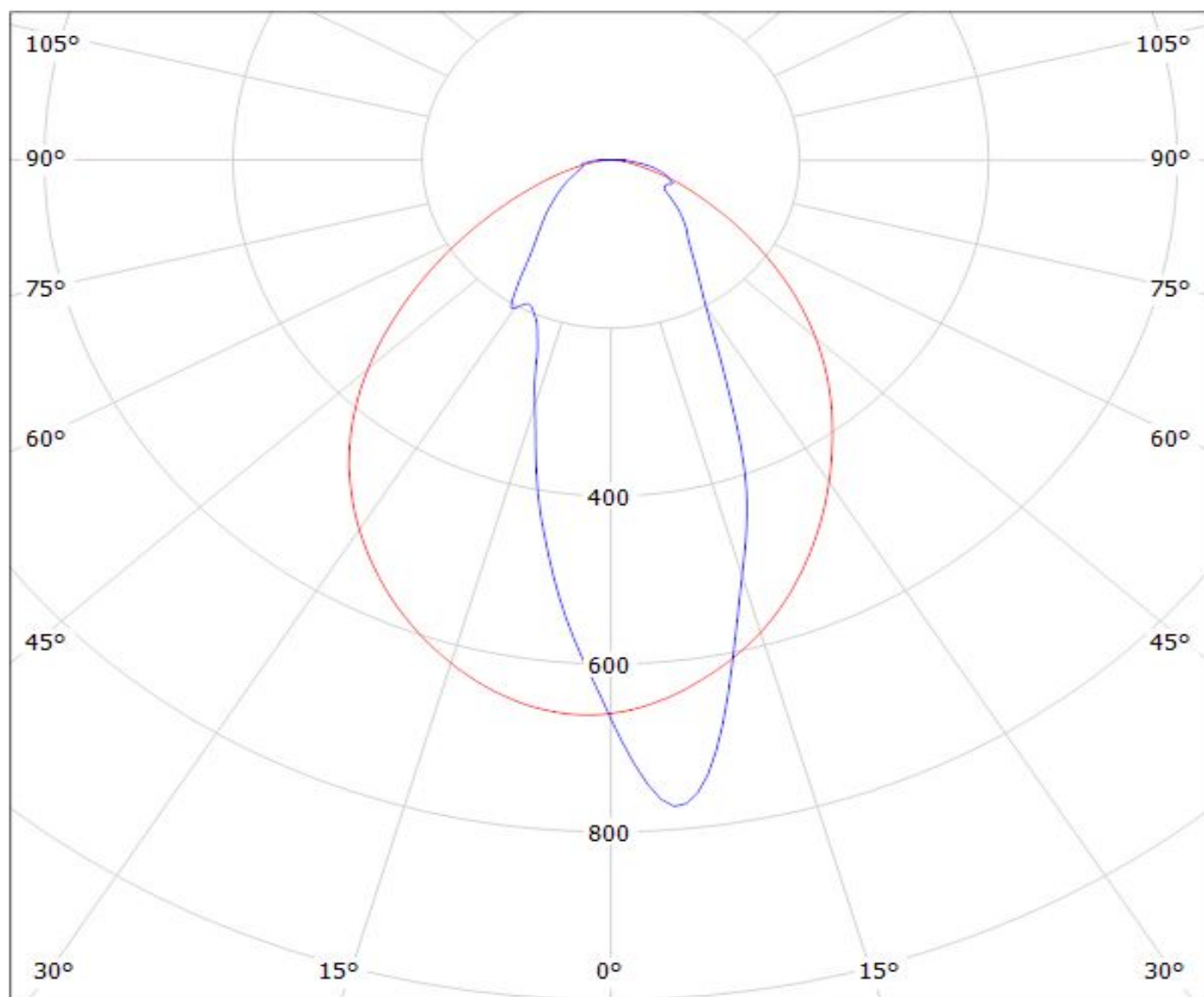

cd/klm

— C0 - C180    — C90 - C270

$\eta = 90\%$

# Ledil F14487\_FLORENCE-1R-MAXI-WG\_(XP-G) / LDC (Polar)

Luminaire: Ledil F14487\_FLORENCE-1R-MAXI-WG\_(XP-G)

Lamps: 1 x Cree\_XP-G\_x12\_(XPGWHT-L1-CWPI-00BE7)\_795.108lm@250mA\_P=8.6W\_I=0.25A

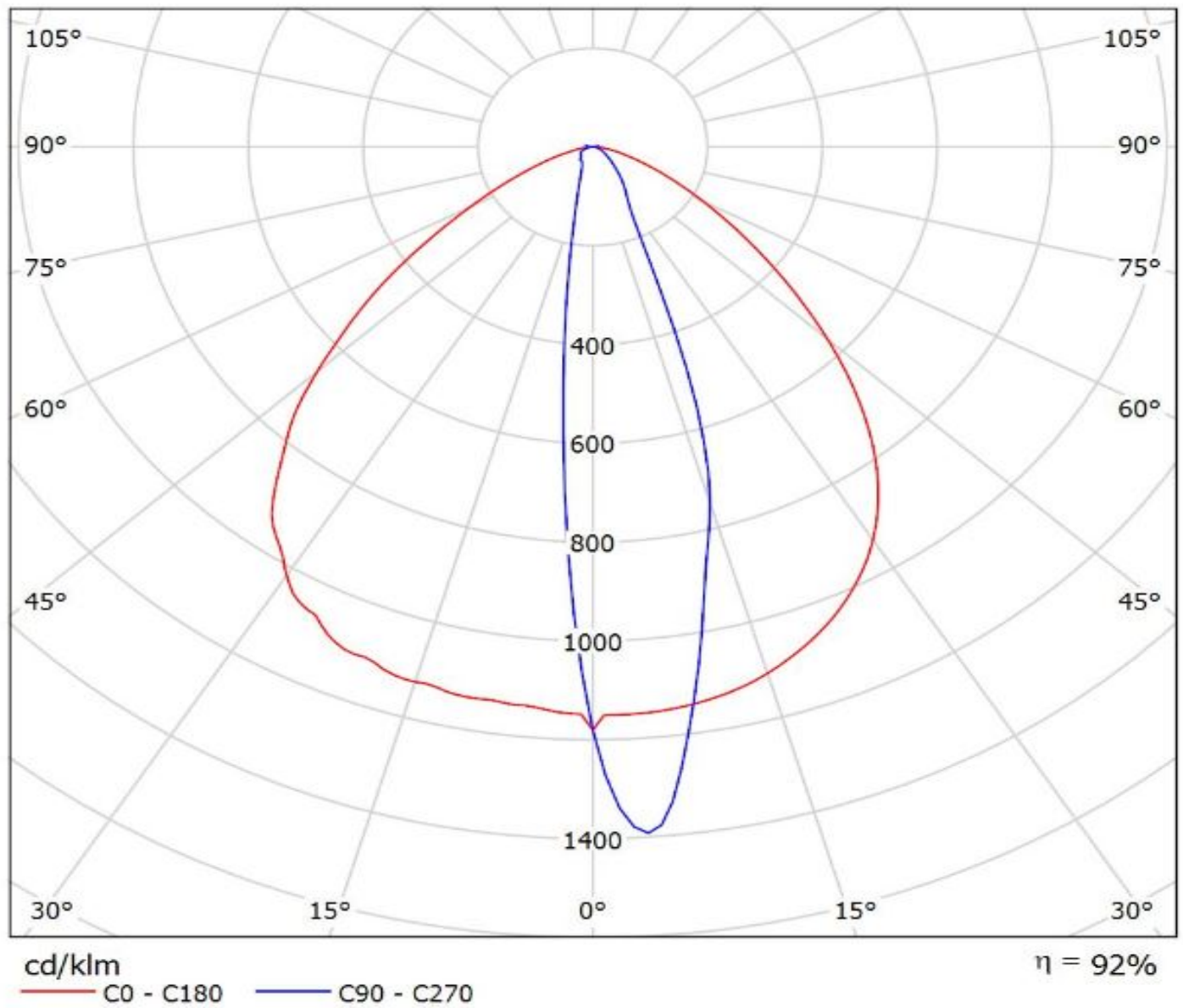

Luminaire: LEDiL Oy F14487\_FLORENCE-1R-MAXI-WG\_(XP-E2)\_2

Lamps: 1 x (XP-E2\_florence)\_881.969lm@250mA\_P=8.62385W\_I=0.2498mA

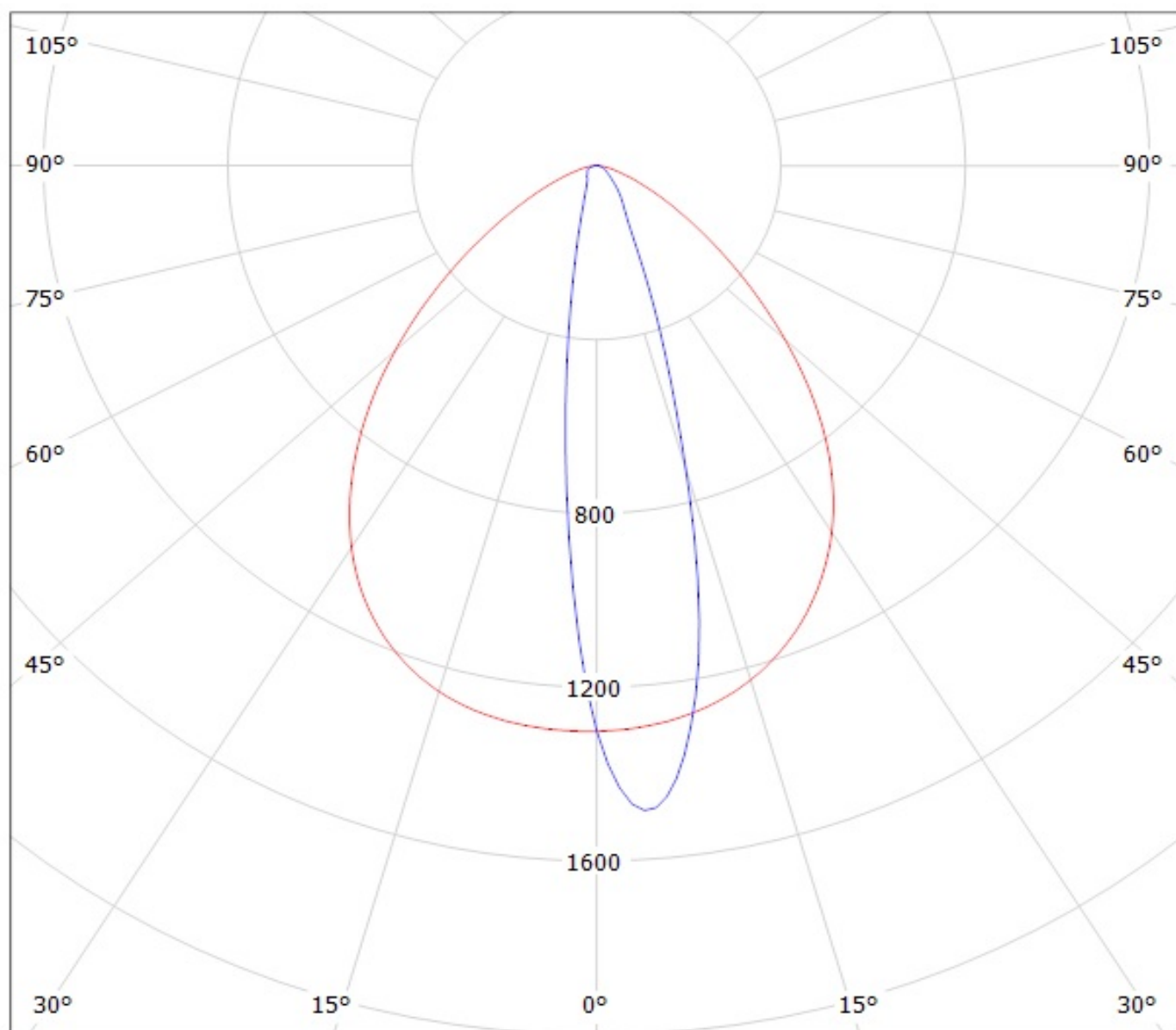

cd/klm

— C0 - C180

— C90 - C270

$\eta = 95\%$

# Ledil F14487\_FLORENCE-1R-MAXI-WG\_(XP-E) / LDC (Polar)

Luminaire: Ledil F14487\_FLORENCE-1R-MAXI-WG\_(XP-E)

Lamps: 1 x Cree\_XP-E\_x12\_(XPEWHT-L1-3C0-Q5-0-06)\_941.258lm@250mA\_P=9W\_I=0.25A

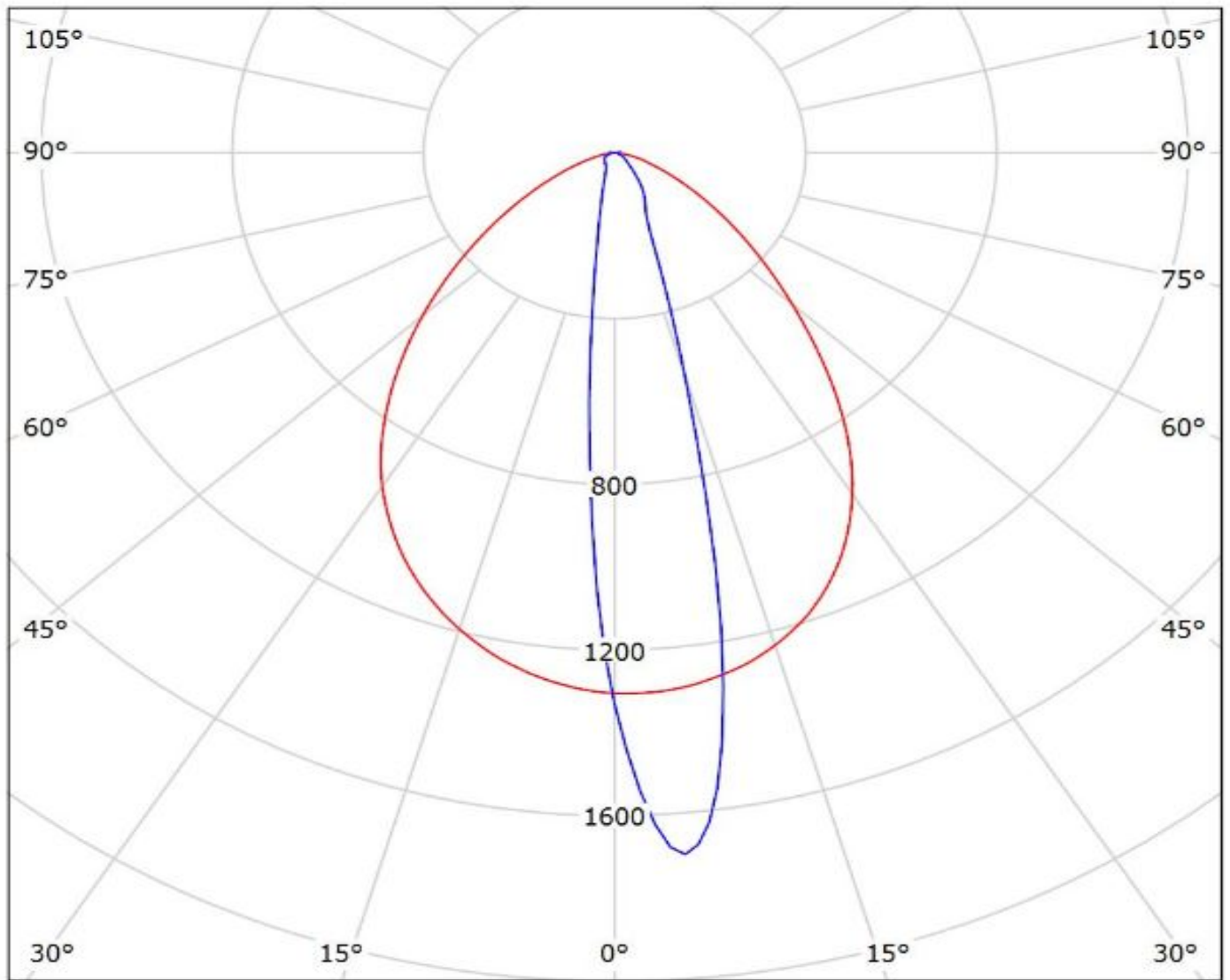

cd/klm

— C0 - C180    — C90 - C270

$\eta = 91\%$

Luminaire: LEDiL Oy F14487\_FLORENCE-1R-MAXI-WG\_(XQ-E)

Lamps: 1 x CREE\_XQ-E\_(XQEAWT-0-7B1-Q40-0H-00001)\_872.003lm@250mA\_P=8.58163W\_I=249.8mA

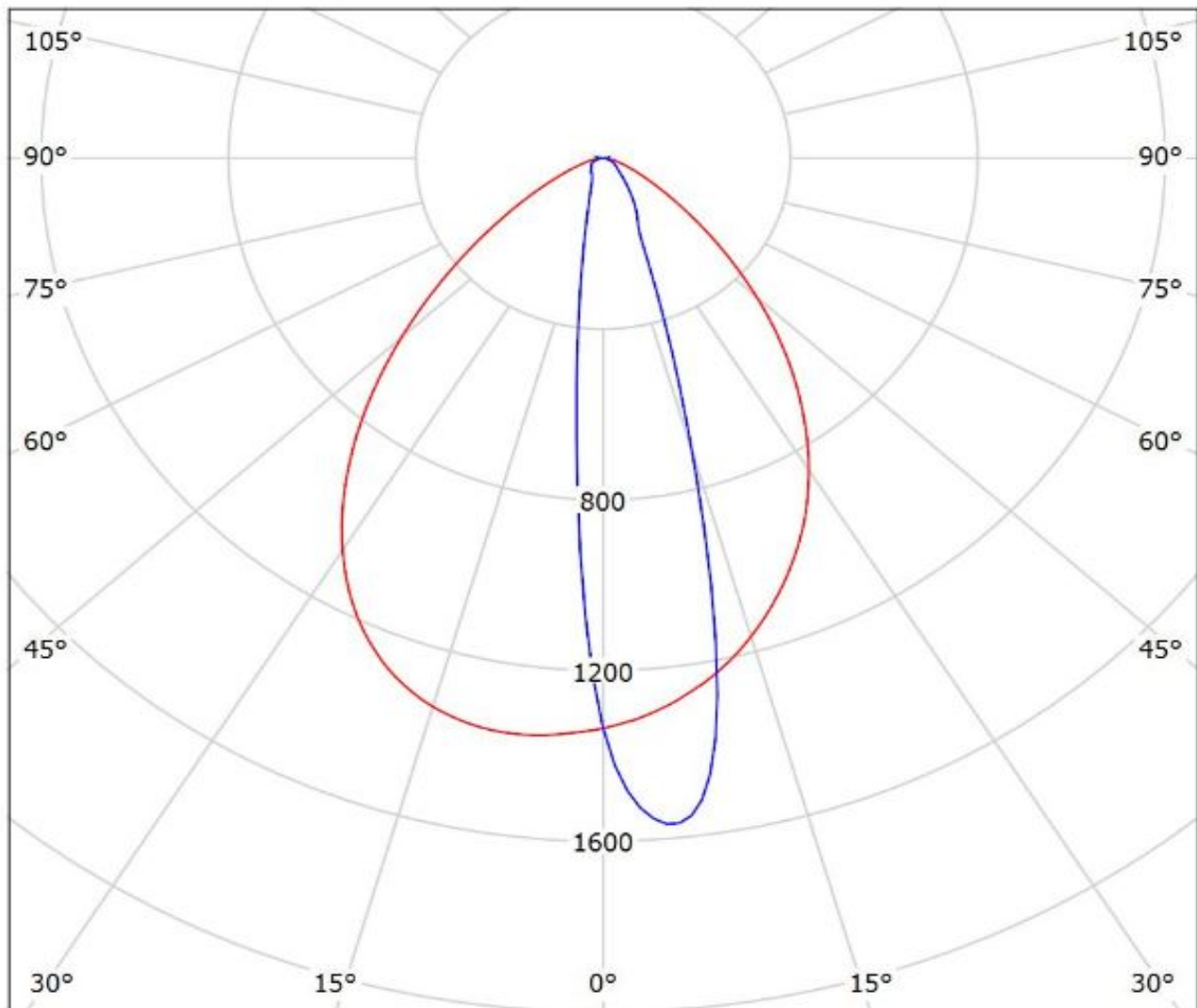

$\eta = 95\%$

cd/klm

— C0 - C180 — C90 - C270

# Ledil F14487\_FLORENCE-1R-MAXI-WG\_(XP-G2) / LDC (Polar)

Luminaire: Ledil F14487\_FLORENCE-1R-MAXI-WG\_(XP-G2)

Lamps: 1 x Cree\_XP-G2\_x12\_(XPGBWT-01-4A0-R3-0-01)\_1206.16lm@250mA\_P=8.5W\_η=0.25A

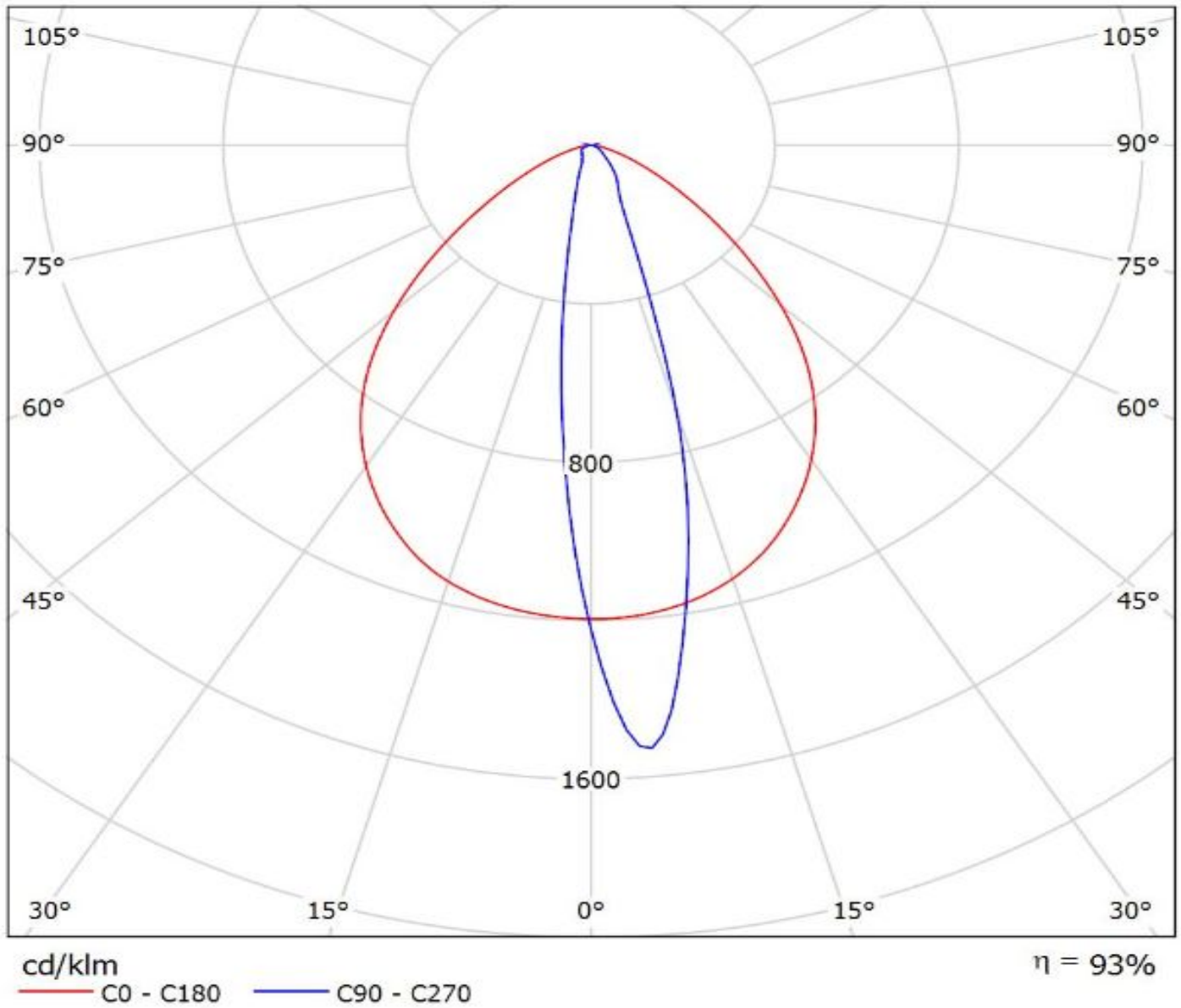

# Ledil F14487\_FLORENCE-1R-MAXI-WG\_(Rebel-ES) / LDC (Polar)

Luminaire: Ledil F14487\_FLORENCE-1R-MAXI-WG\_(Rebel-ES)

Lamps: 1 x Luxeon\_Rebel-ES\_x12\_(LXML-PWC2)\_1141.53lm@250mA\_P=8.65W\_I=0.25A

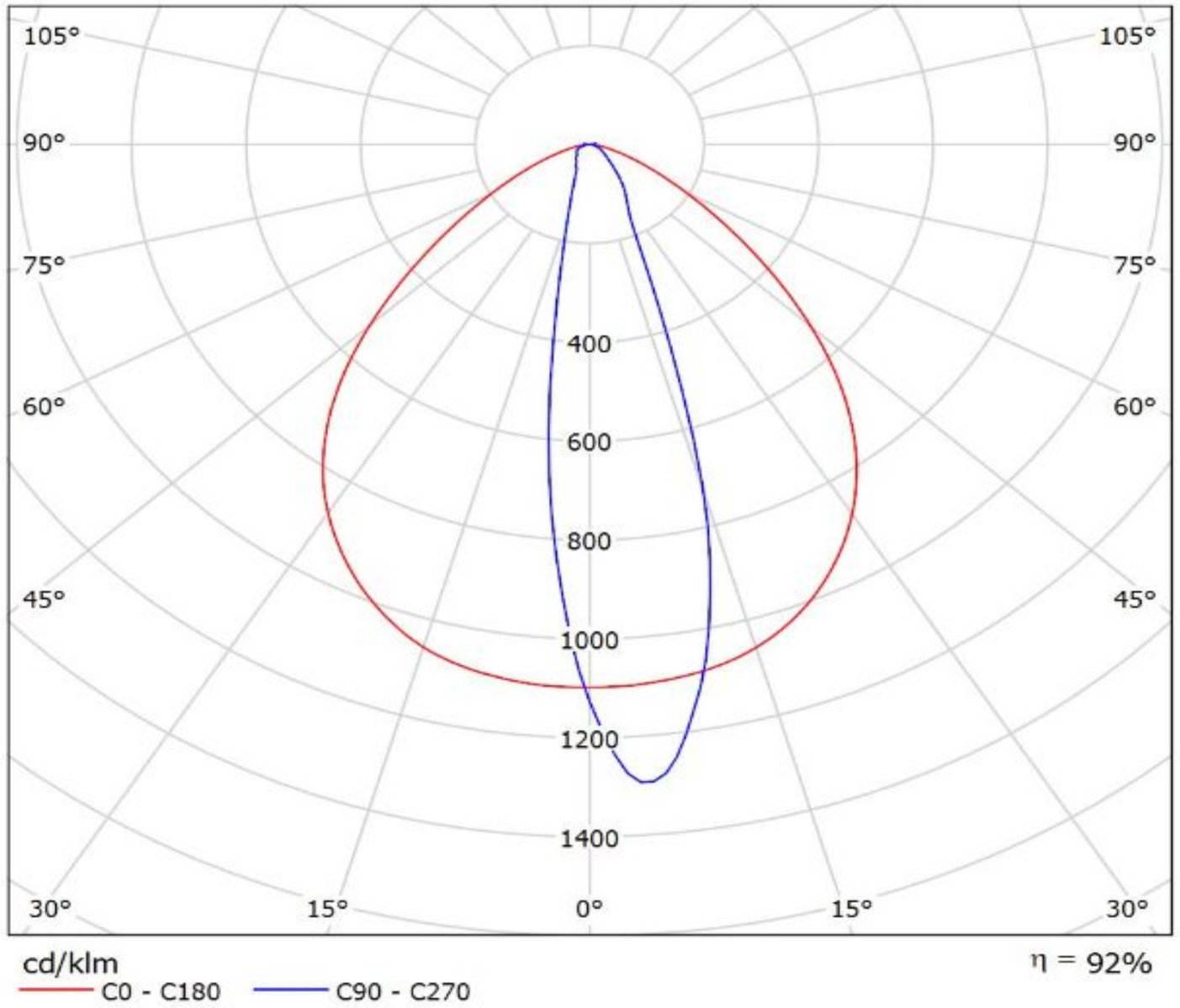

# Ledil F14487\_FLORENCE-1R-MAXI-WG\_(Rebel) / LDC (Polar)

Luminaire: Ledil F14487\_FLORENCE-1R-MAXI-WG\_(Rebel)

Lamps: 1 x Luxeon\_Rebel\_x12\_(LXM8-PW30)\_763.184lm@250mA\_P=8.3W\_I=0.25A

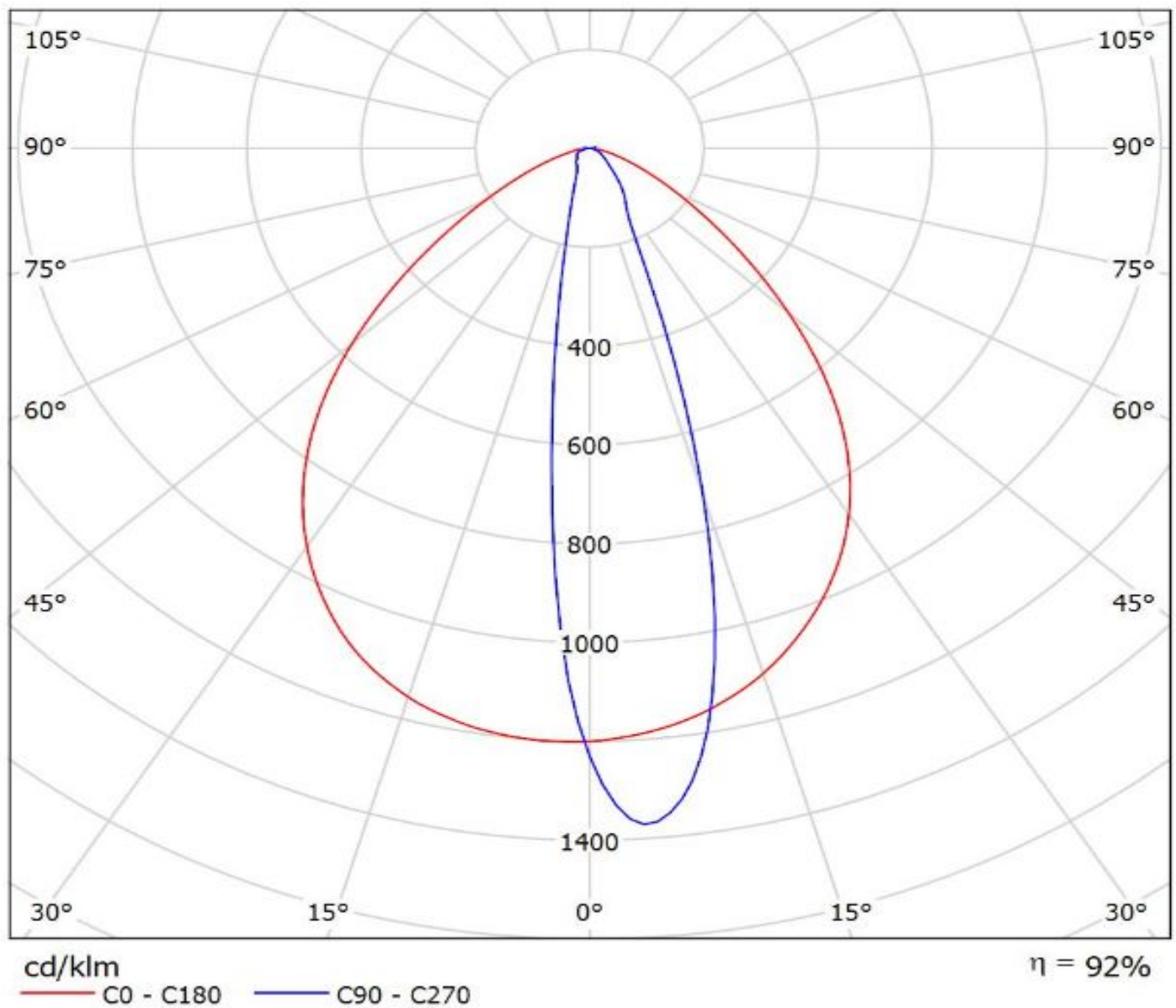

# Ledil F14487\_FLORENCE-1R-MAXI-WG\_(Luxeon\_A) / LDC (Polar)

Luminaire: Ledil F14487\_FLORENCE-1R-MAXI-WG\_(Luxeon\_A)

Lamps: 1 x Luxeon\_A\_x12\_(LXH8-PW30)\_834.791lm@250mA\_P=8.3W\_I=0.25A

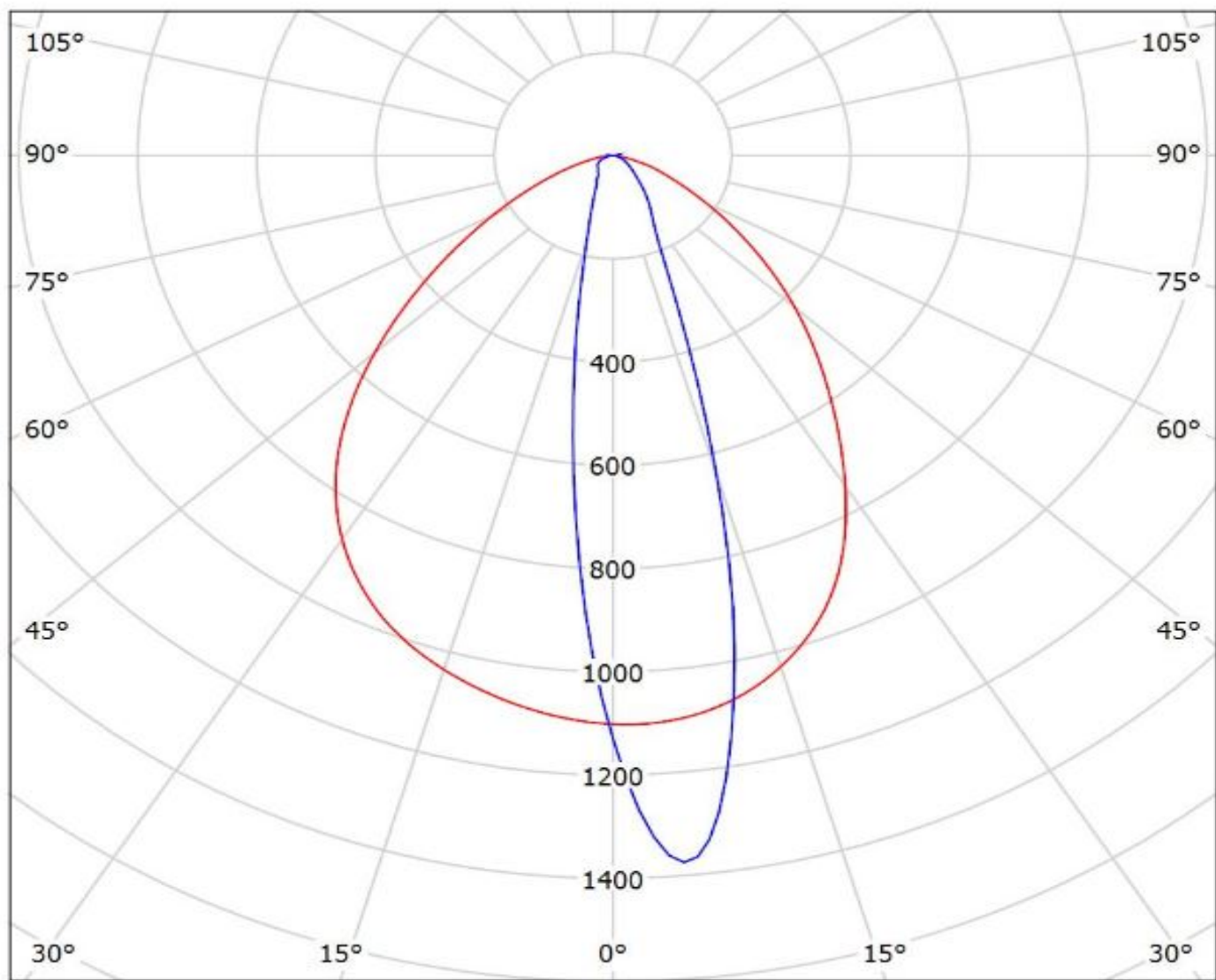

cd/klm

— C0 - C180 — C90 - C270

$\eta = 92\%$

Luminaire: LEDiL Oy F14487\_FLORENCE-1R-MAXI-WG\_(LUXEON\_Z-ES)

Lamps: 1 x LUXEON\_Z-ES\_(LXZ2-3080-3)\_882.543lm@250mA\_CCT=3000K\_P=8.27363W\_I=249.8mA

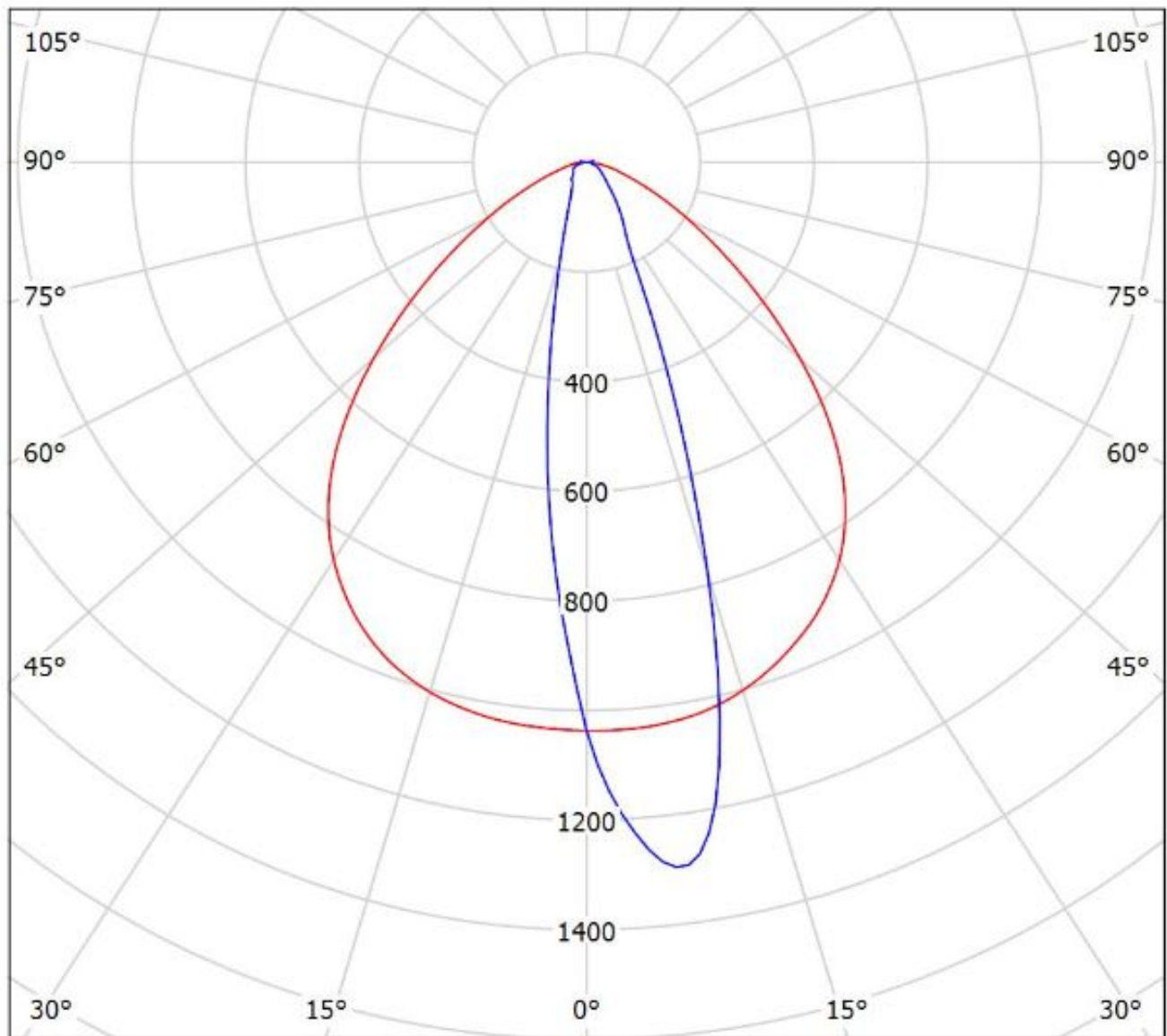

cd/klm

— C0 - C180 — C90 - C270

$\eta = 94\%$

# Ledil F14487\_FLORENCE-1R-MAXI-WG\_(Luxeon\_3030\_2D) / LDC (Polar)

Luminaire: Ledil F14487\_FLORENCE-1R-MAXI-WG\_(Luxeon\_3030\_2D)  
Lamps: 1 x Luxeon\_3030\_2D\_x22\_(L130-4080003000W21)  
\_1602.96lm@200mA\_CCT=4000K\_P=12.8W\_I=0.2A

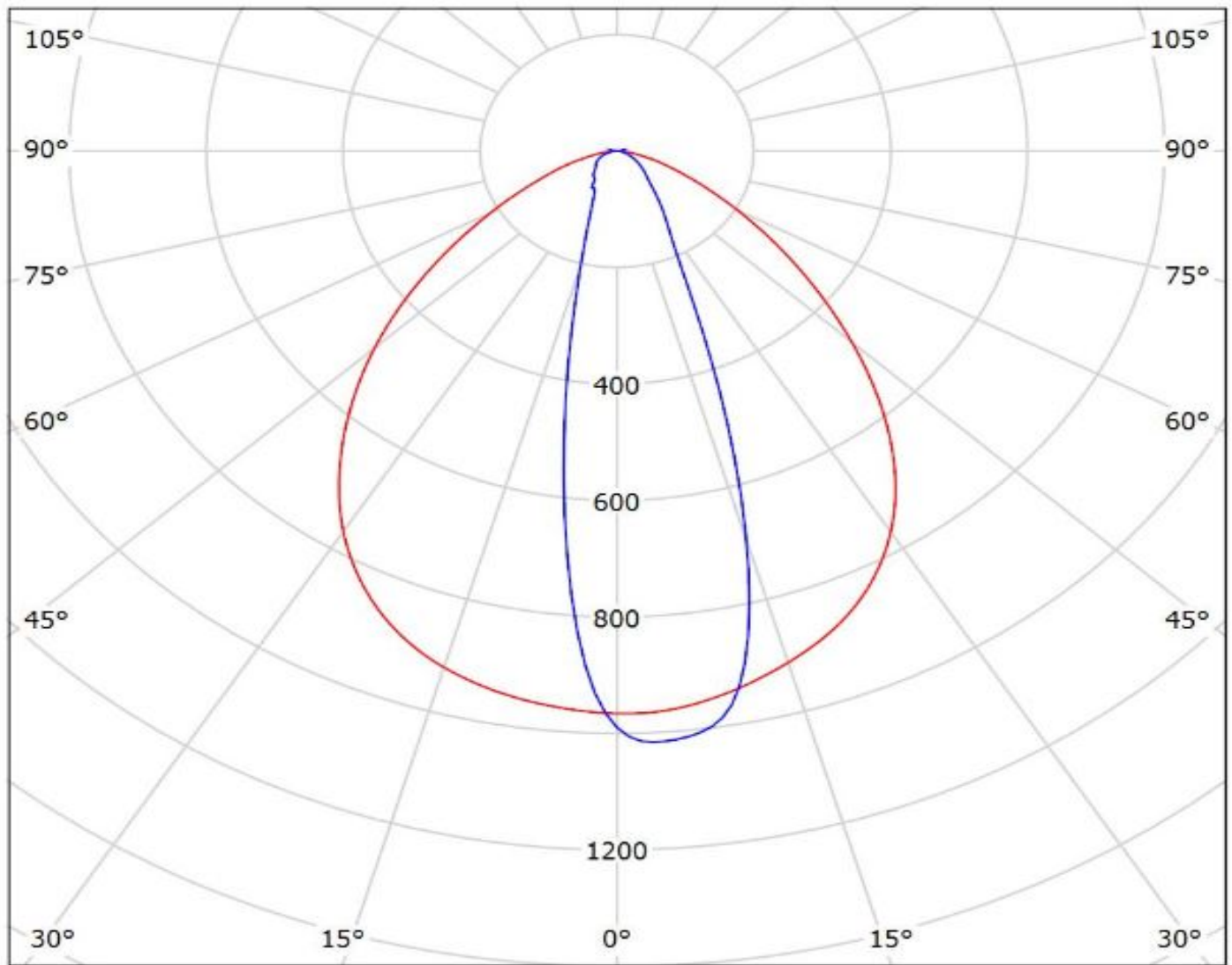

cd/klm  
— C0 - C180 — C90 - C270

η = 91%

Luminaire: Ledil F14487\_FLORENCE-1R-MAXI-WG\_(3014\_x22)

Lamps: 1 x Luxeon\_3014\_x22\_(L130-5080)\_283.511lm@60mA\_P=1.9087W\_I=0.060mA

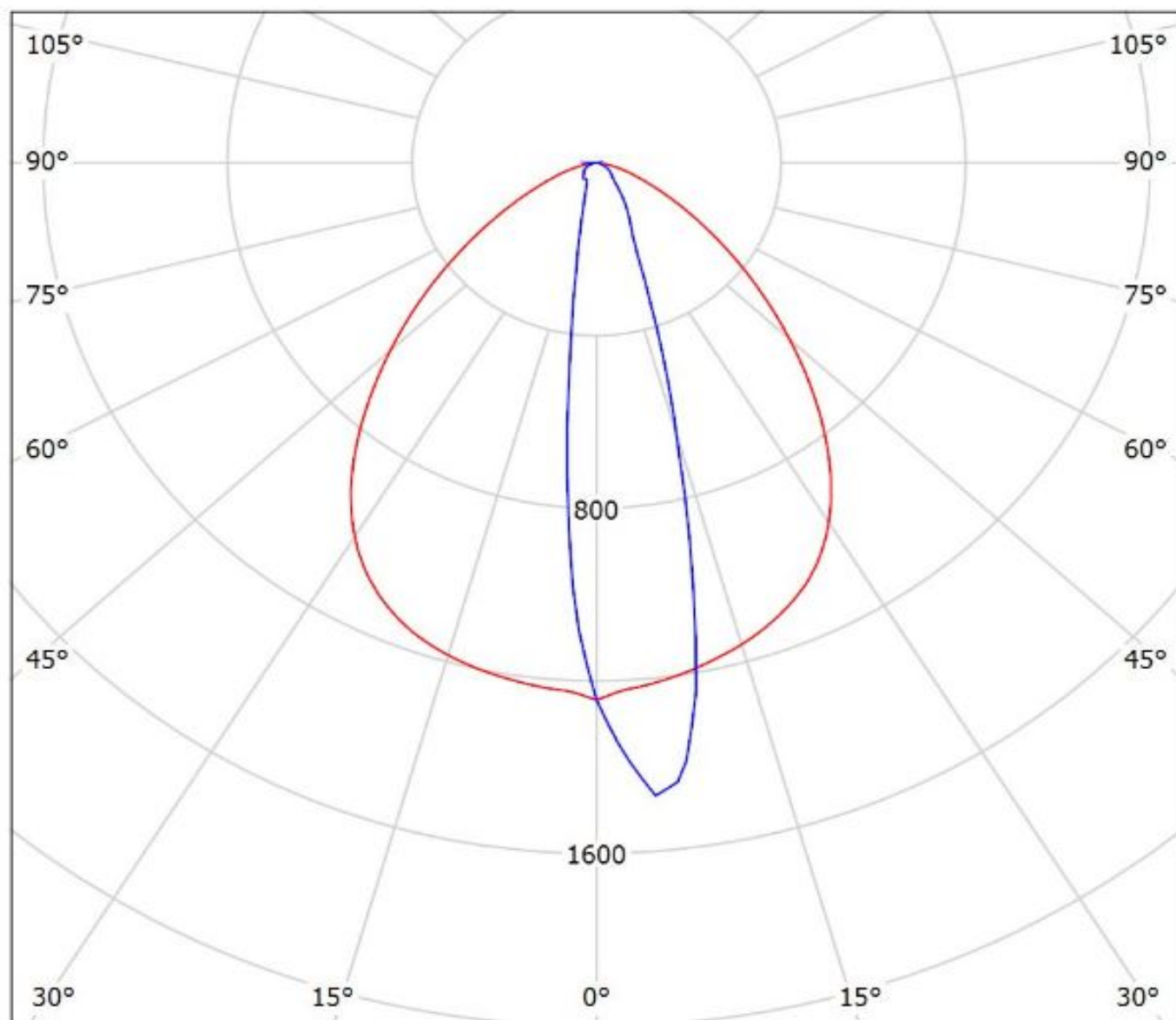

cd/klm

— C0 - C180 — C90 - C270

$\eta = 93\%$

# Ledil F14487\_FLORENCE-1R-MAXI-WG\_(NCSxx19B) / LDC (Polar)

Luminaire: Ledil F14487\_FLORENCE-1R-MAXI-WG\_(NCSxx19B)

Lamps: 1 x Nichia\_NCSxx19B\_x12\_(NCSL219B)\_941.258lm@250mA\_P=8.9W\_I=0.25A

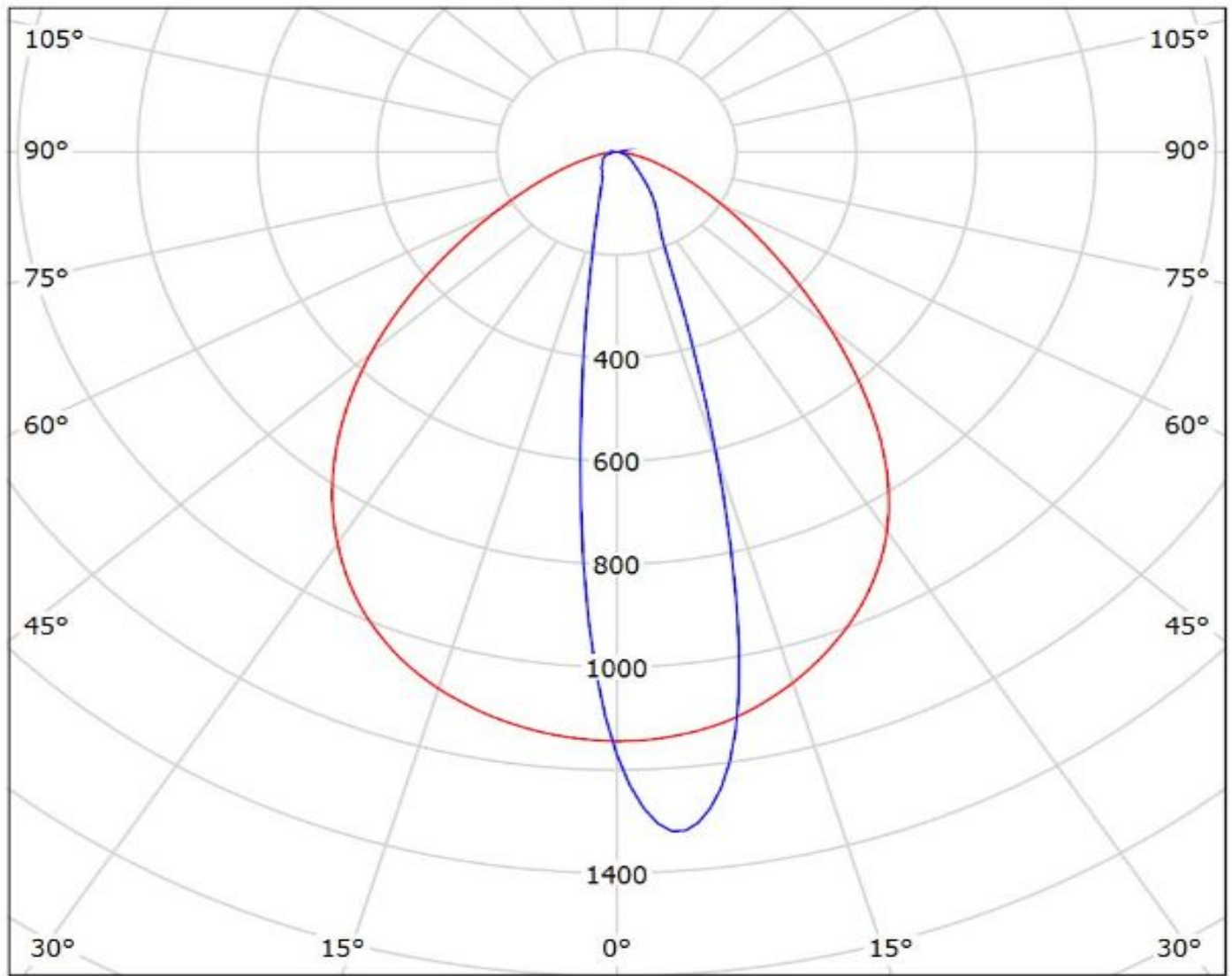

cd/klm

— C0 - C180

— C90 - C270

$\eta = 91\%$

# Ledil F14487\_FLORENCE-1R-MAXI-WG\_(NVSxx19B) / LDC (Polar)

Luminaire: Ledil F14487\_FLORENCE-1R-MAXI-WG\_(NVSxx19B)

Lamps: 1 x Nichia\_NVSxx19B\_x12\_(NVSL219B)\_1045.07lm@250mA\_P=8.6W\_I=0.25A

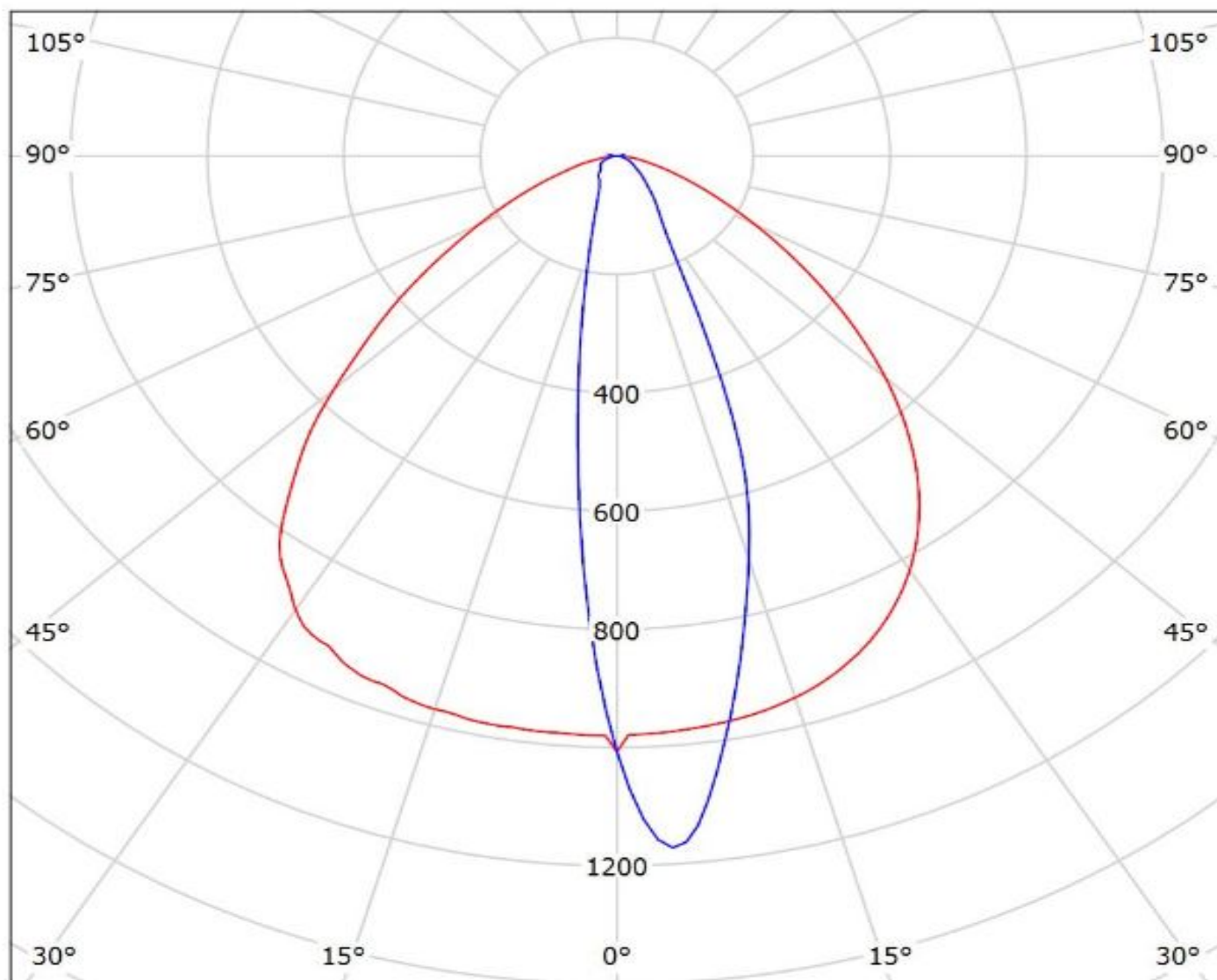

cd/klm

— C0 - C180 — C90 - C270

$\eta = 91\%$

Luminaire: Ledil F14487\_FLORENCE-1R-MAXI-WG\_(NF2W757G)  
Lamps: 1 x NF2W757G\_378.284lm@65mA\_CCT=?K\_P=1.97W\_l=0.065A

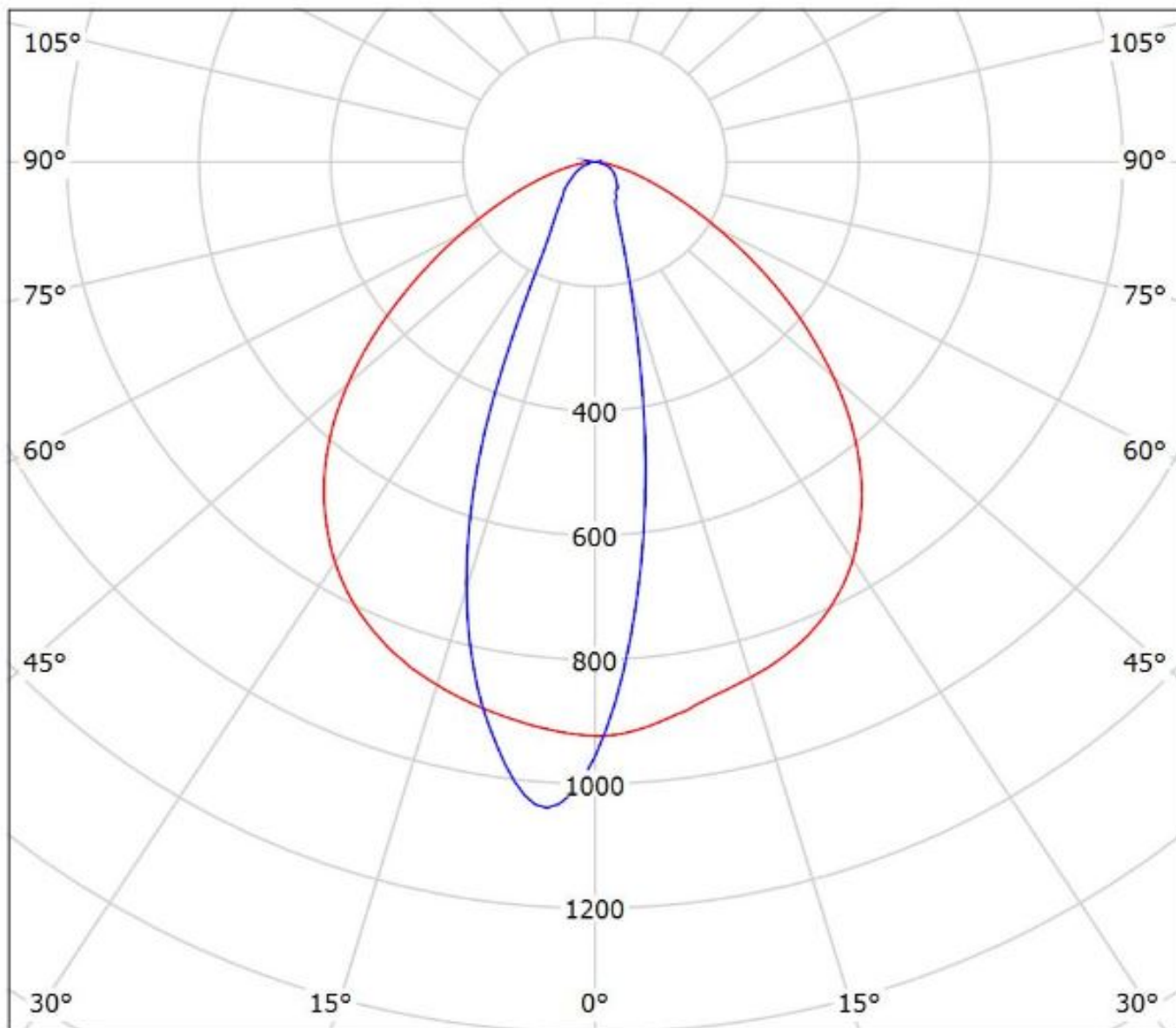

cd/klm  
— C0 - C180 — C90 - C270

$\eta = 90\%$

# Ledil F14487\_FLORENCE-1R-MAXI-WG\_(Duris\_S5-2chip) / LDC (Polar)

Luminaire: Ledil F14487\_FLORENCE-1R-MAXI-WG\_(Duris\_S5-2chip)

Lamps: 1 x Osram\_Duris\_S5-2chip\_x22\_1225.67lm@150mA\_P=9.55W\_I=150mA

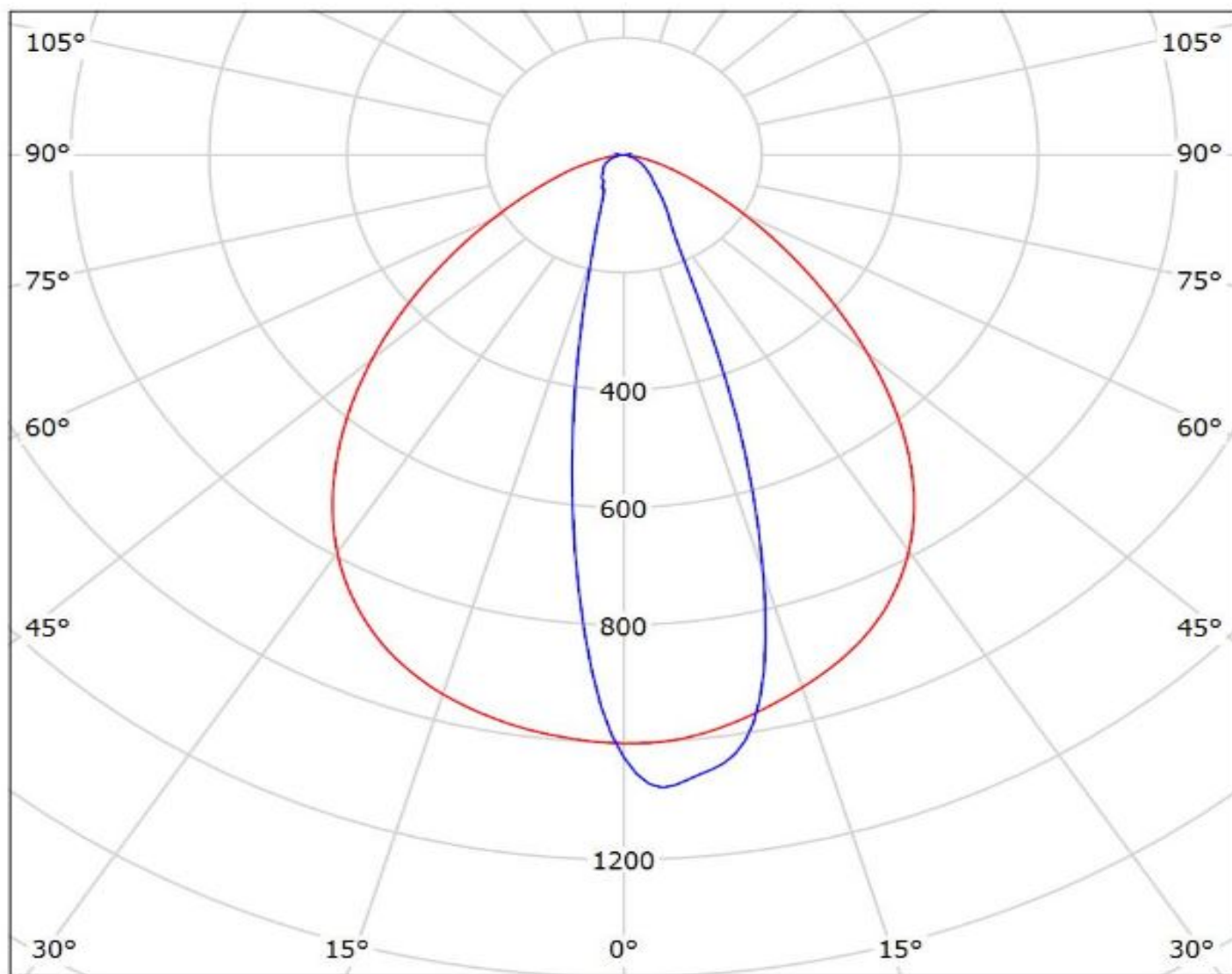

cd/klm

— C0 - C180 — C90 - C270

$\eta = 91\%$

# Ledil F14487\_FLORENCE-1R-MAXI-WG\_(SSL80) / LDC (Polar)

Luminaire: Ledil F14487\_FLORENCE-1R-MAXI-WG\_(SSL80)

Lamps: 1 x Osram\_Oslon\_SSL80\_x12\_(LCW\_CQ7P.EC)\_838.967lm@250mA\_P=9.3W\_I=0.25A

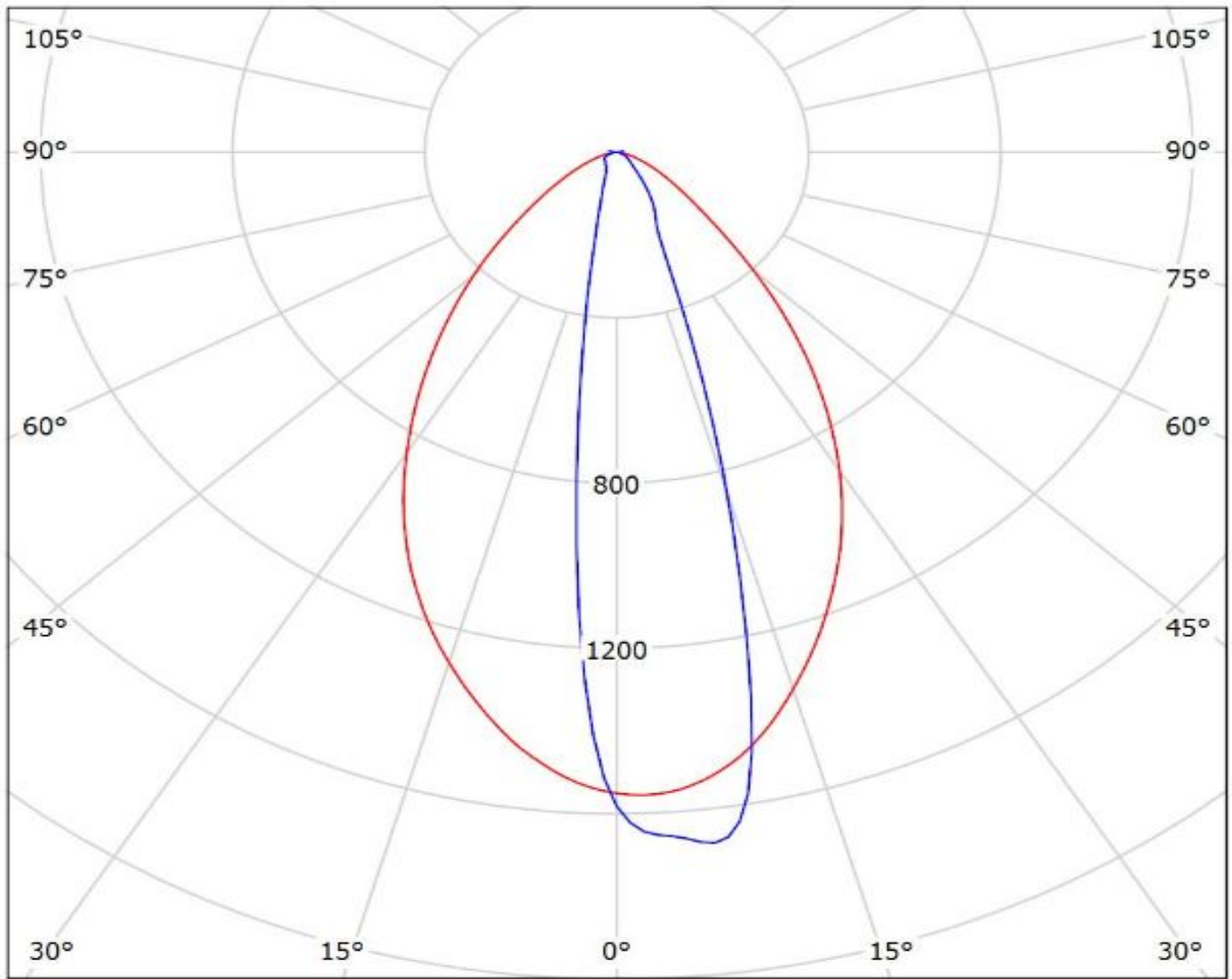

cd/klm

— C0 - C180 — C90 - C270

$\eta = 93\%$

Luminaire: LEDiL Oy F14487\_FLORENCE-1R-MAXI-WG\_(Fortimo\_LED\_line\_1ft\_1100lm\_840\_1R\_LV2)  
Lamps: 1 x Philips\_Fortimo\_LED\_line\_1ft\_1100lm\_840\_1R\_LV2\_1067.99lm@250mA\_P=8.04281W\_I=0.2498mA

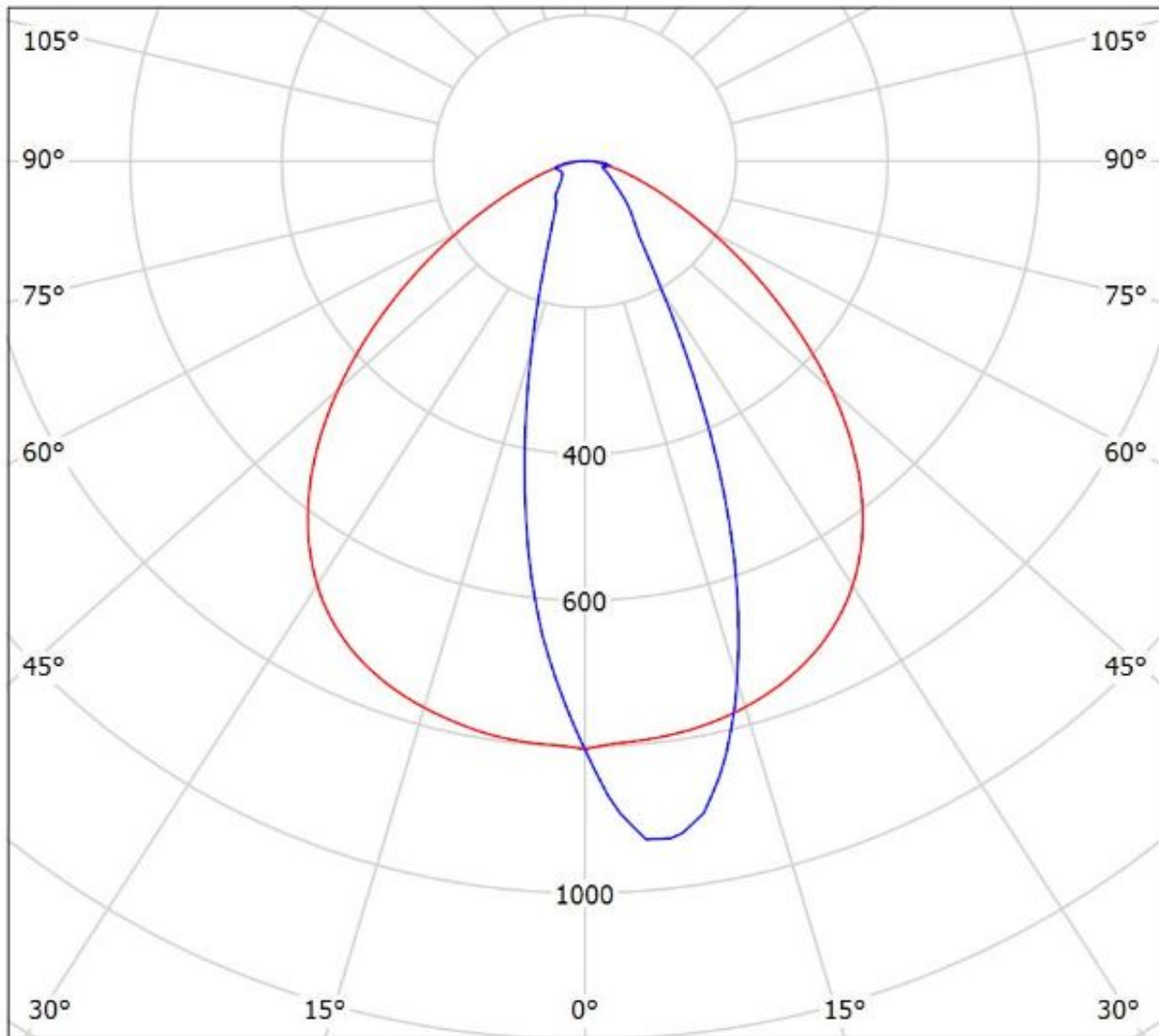

cd/klm  
— C0 - C180 — C90 - C270

$\eta = 94\%$

Luminaire: Ledil F14487\_FLORENCE-1R-MAXI-WG\_(LT-S282N)

Lamps: 1 x Samsung SI-B8T071280LD\_LM5618+\_1401.55lm@250mA\_P=9.185W\_I=0.25A

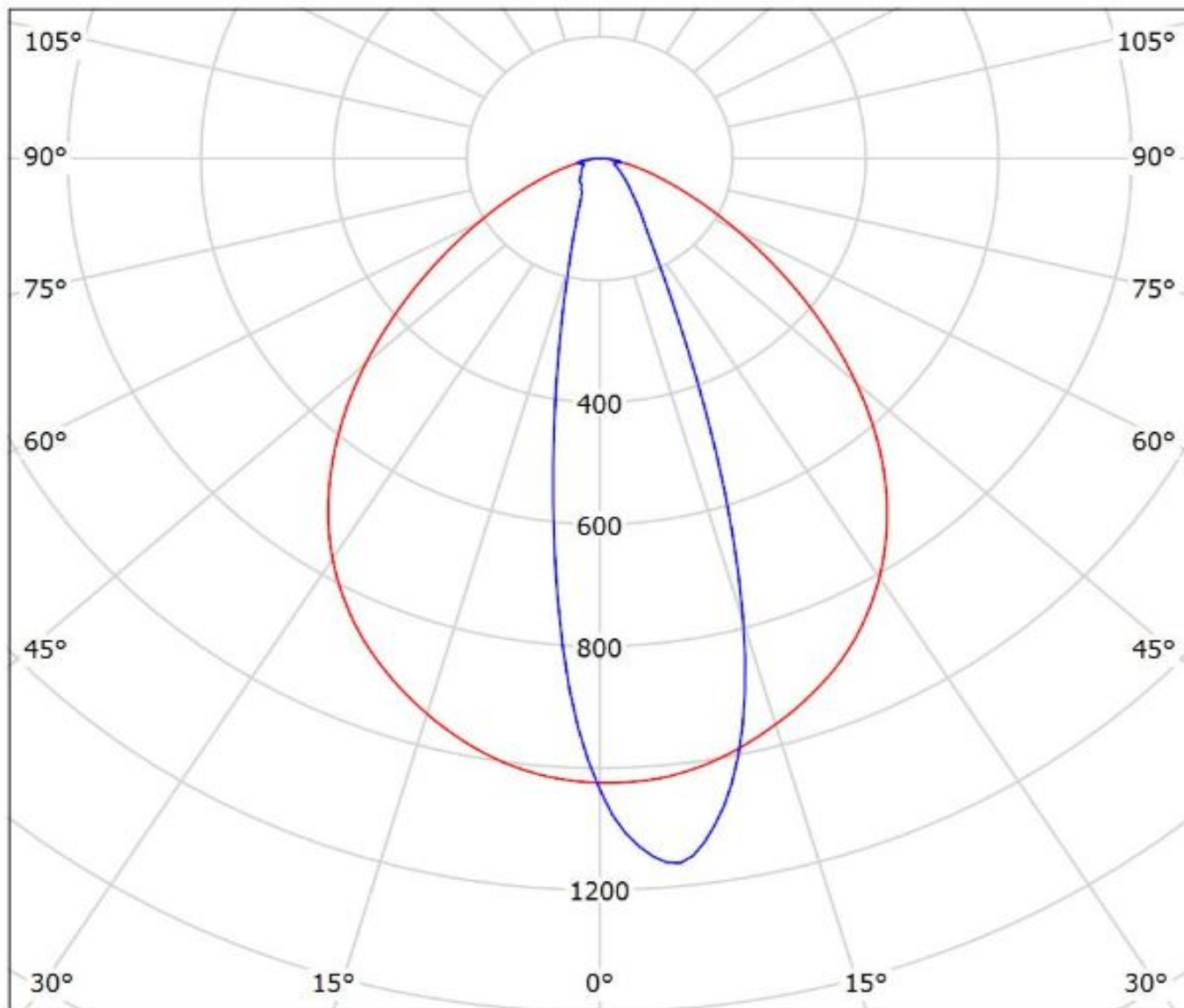

cd/klm

— C0 - C180 — C90 - C270

$\eta = 94\%$

Luminaire: Ledil F14487\_FLORENCE-1R-MAXI-WG\_(LM301A)

Lamps: 1 x Samsung\_LM301A\_x11\_(SPMWHT328FD5WAT0S0)\_1107.77lm@250mA\_P=8.1W\_I=0.25A

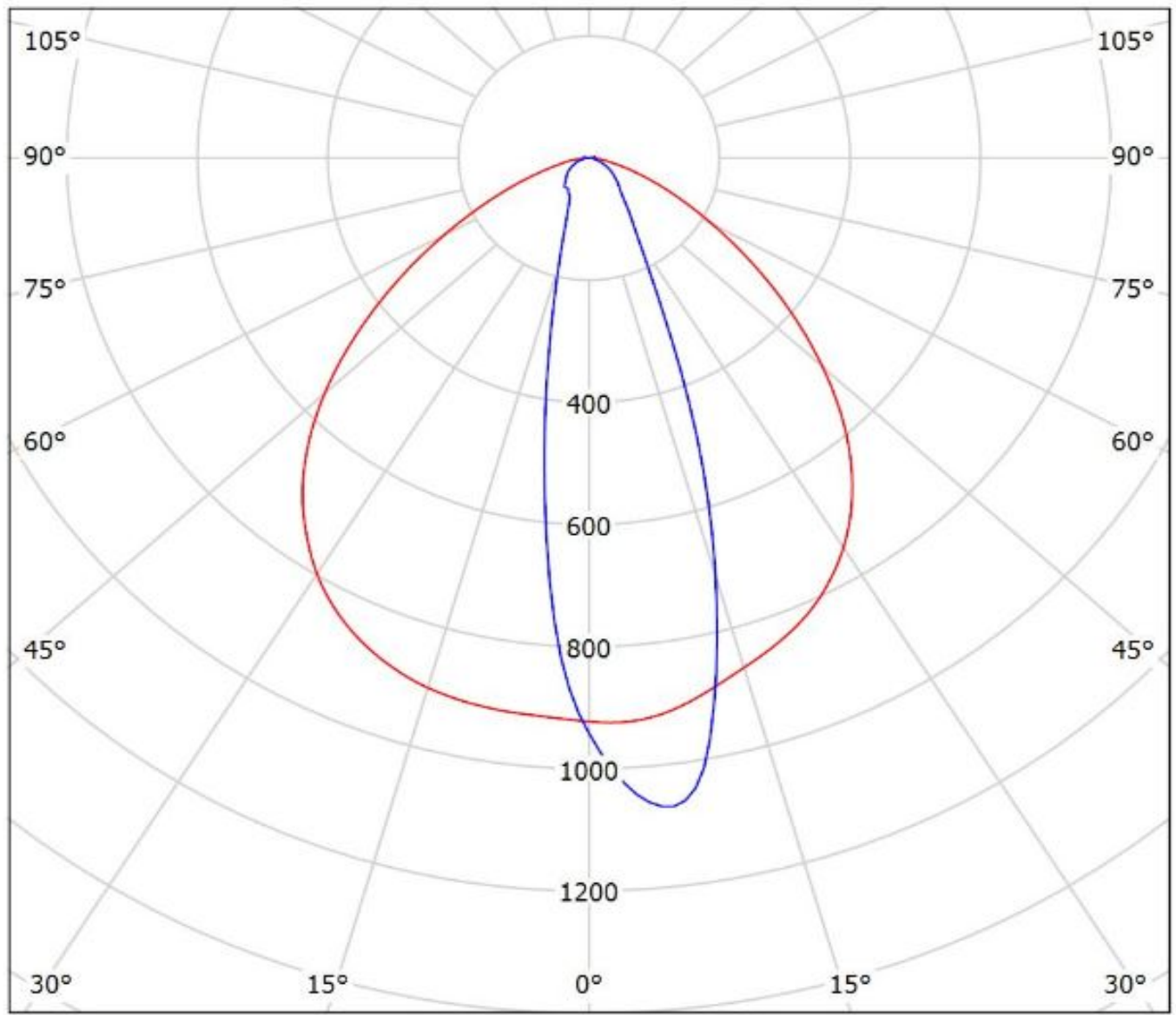

cd/klm

— C0 - C180

— C90 - C270

$\eta = 91\%$

Luminaire: LEDiL Oy F14487\_FLORENCE-1R-MAXI-WG\_(LM561C)  
Lamps: 1 x Samsung\_LM561C\_685.154lm@130mA\_P=3.9367W\_I=0.130A

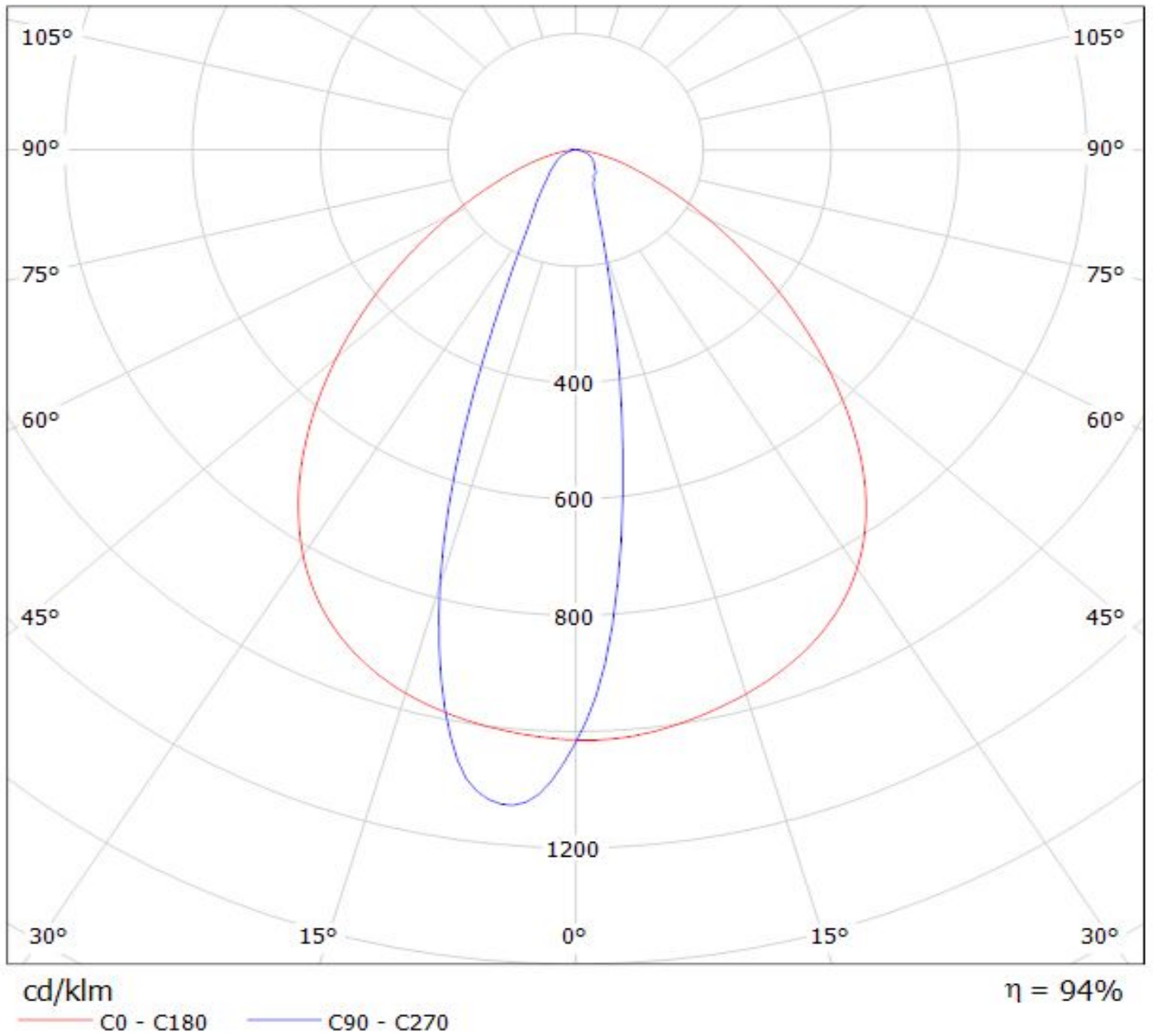

Luminaire: Ledil F14487\_FLORENCE-1R-MAXI-WG\_(CALGD0414-M8W1)

Lamps: 1 x Citizen\_(CALGD0414-M8W1)\_556.672lm@350mA\_P=4.0291W\_I=0.3499A

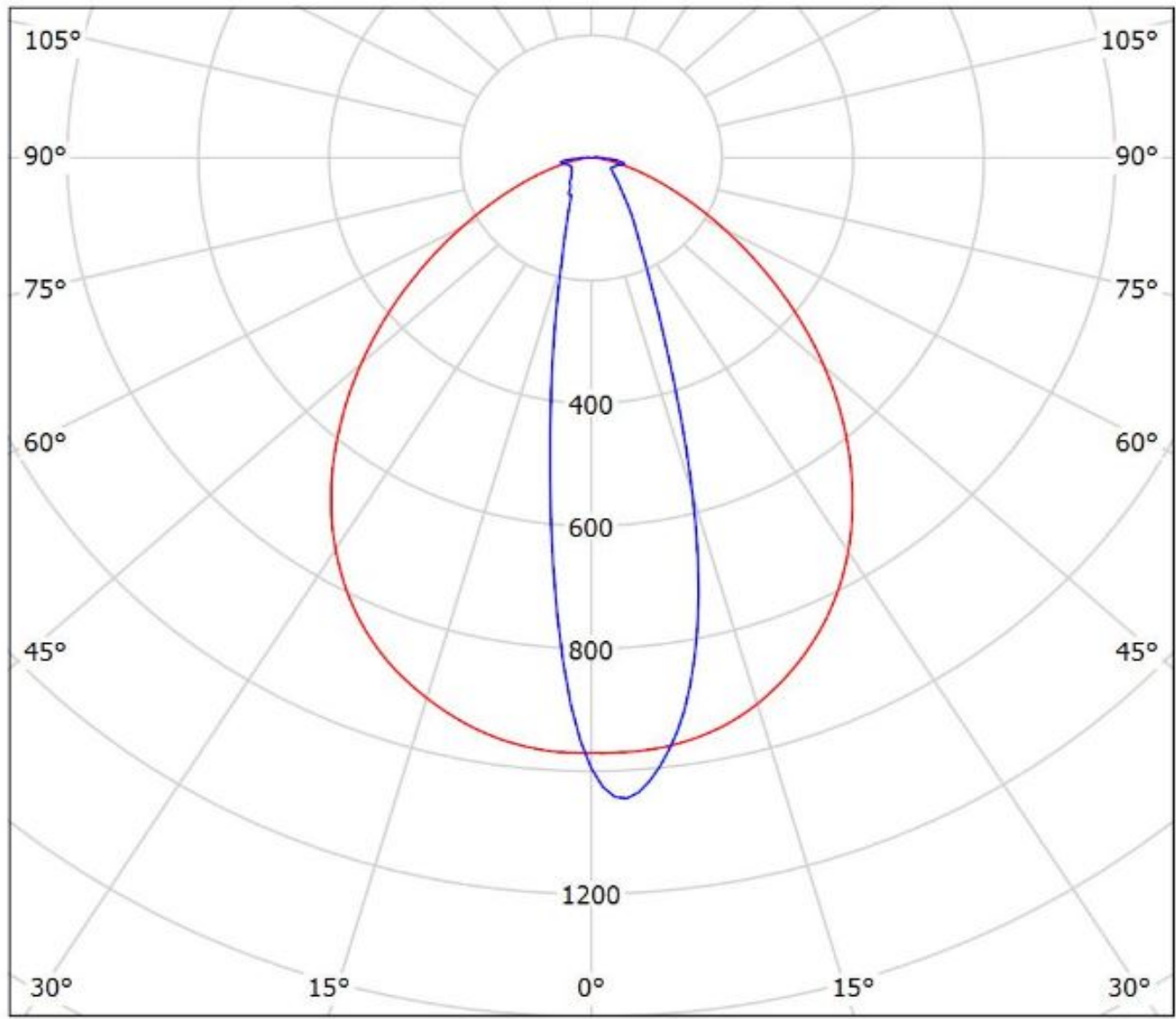

cd/klm  
— C0 - C180 — C90 - C270

$\eta = 92\%$

Luminaire: Ledil F14487\_FLORENCE-1R-MAXI-WG\_(CALGD0814-M17W1)  
Lamps: 1 x CALGD0814-M17W1\_1094.82lm@350mA\_P=7.9555W\_I=0.35A

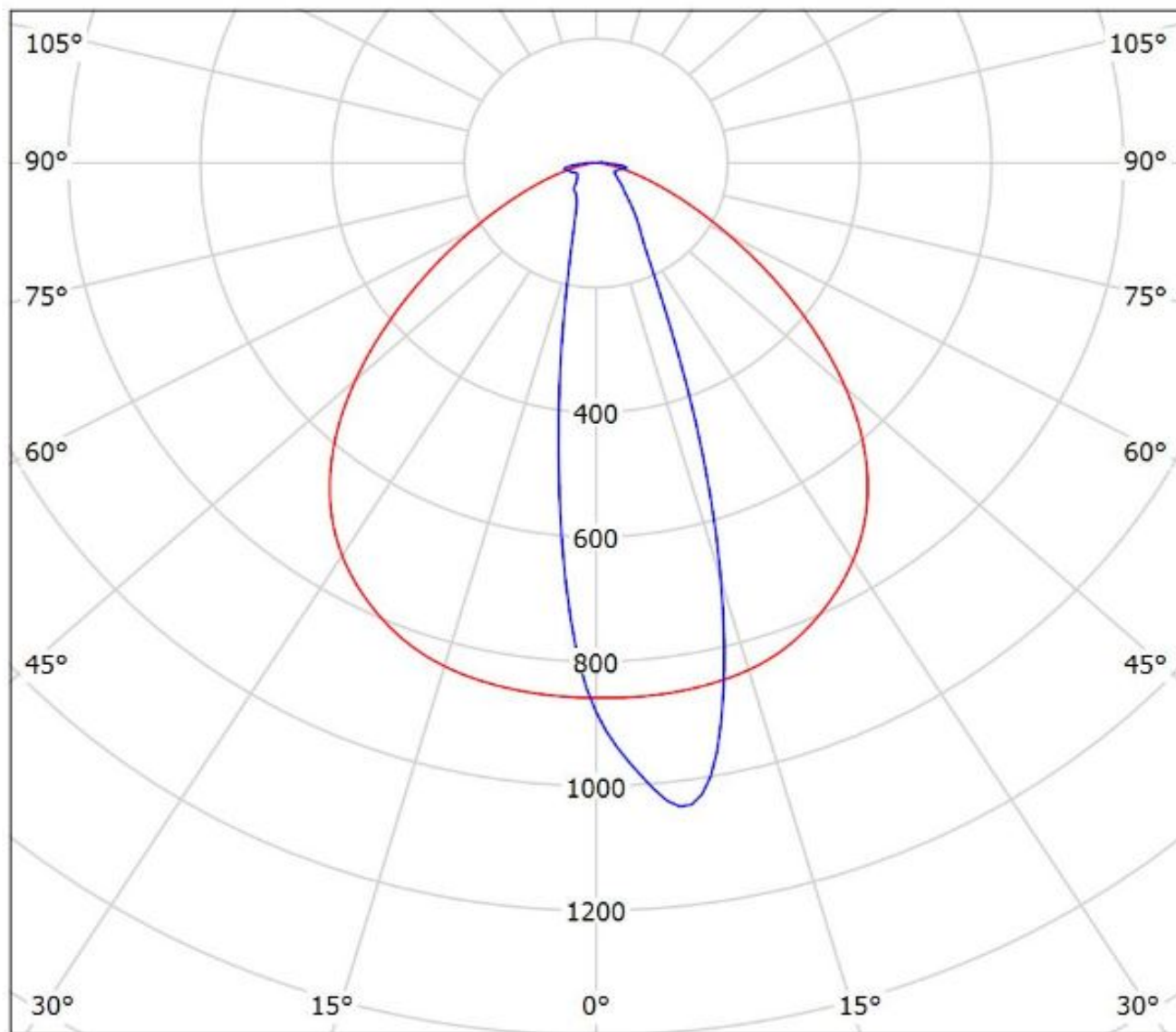

cd/klm

— C0 - C180    — C90 - C270

$\eta = 91\%$

**NOTE: The typical divergence will be changed by different color, chip size and chip position tolerance. The typical total divergence is the full angle measured where the luminous intensity is half of the peak value.**