

Distributed by:

JAMECO[®]
ELECTRONICS

www.Jameco.com ♦ 1-800-831-4242

The content and copyrights of the attached
material are the property of its owner.

Jameco Part Number 2042351

MAXIM

±15kV ESD-Protected, Quad, Low-Power RS-232 Line Driver

General Description

The MAX1488E quad, low-power line driver is designed for EIA/TIA-232, EIA/TIA-562, and CCITT V.28 communications in harsh environments. Each transmitter output is protected against ±15kV electrostatic discharge (ESD) shocks. The inputs are TTL and CMOS compatible with minimal loading. The outputs feature internally controlled slew-rate limiting and current limiting. This device has a guaranteed 120kbps data rate. Power-supply current is less than 180μA over a ±4.5V to ±13.2V supply voltage range.

The MAX1488E is pin compatible with the MC1488, MC14C88, SN75188, SN75C188, DS1488, and DS14C88. It is available in 14-pin plastic DIP and SO packages.

Applications

PC Motherboards
 Modems
 Interface Data Terminal Equipment (DTE) with Data Circuit-Terminating Equipment (DCE)
 Equipment Meeting IEC1000-4-2 (formerly IEC801-2) or ±15kV ESD Protection

Typical Operating Circuit

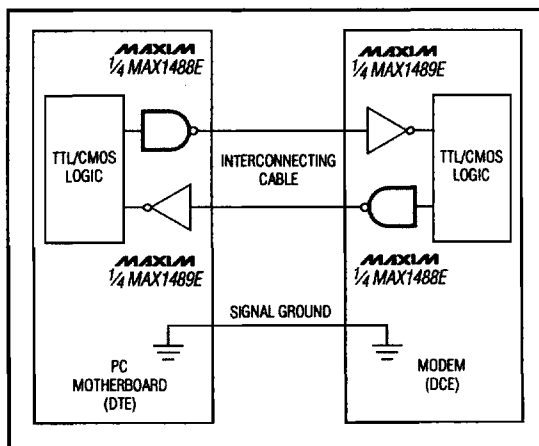

Features

- ◆ ESD Protection:
 - ±15kV—Human Body Model
 - ±6kV—IEC801-2, Contact Discharge
 - ±15kV—IEC801-2, Air-Gap Discharge
- ◆ Latchup Free, Even During an ESD Event
- ◆ Low 85μA Supply Current from IEE or ICC
- ◆ Guaranteed 120kbps Data Rate
- ◆ No External Capacitors Required for Slew-Rate Limiting
- ◆ Pin Compatible with MC1488, MC14C88, SN75188, SN75C188, DS1488, and DS14C88

Ordering Information

PART	TEMP. RANGE	PIN-PACKAGE
MAX1488ECPD	0°C to +70°C	14 Plastic DIP
MAX1488ECSD	0°C to +70°C	14 SO
MAX1488EC/D	0°C to +70°C	Dice*
MAX1488ECPD	-40°C to +85°C	14 Plastic DIP
MAX1488EESD	-40°C to +85°C	14 SO

* Dice are specified at $T_A = +25^\circ\text{C}$.

Pin Configuration

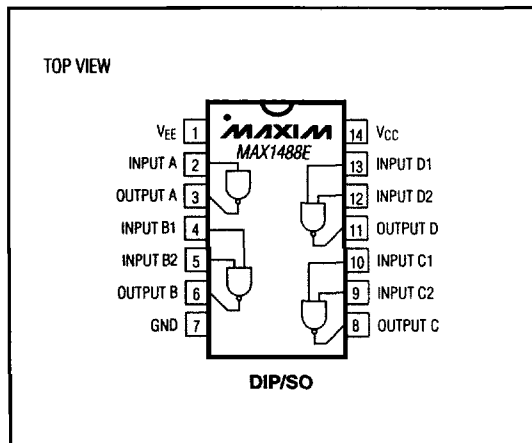

MAX1488E

2

MAXIM

Maxim Integrated Products 2-75

For free samples & the latest literature: <http://www.maxim-ic.com>, or phone 1-800-998-8800

±15kV ESD-Protected, Quad, Low-Power RS-232 Line Driver

ABSOLUTE MAXIMUM RATINGS

Positive Supply Voltage (V _{CC})	+14V
Negative Supply Voltage (V _{EE})	-14V
Input Voltage (V _{IN})	-0.3V to +15V
Driver Output Voltage	±15V
Continuous Power Dissipation (T _A = +70°C)	
Plastic DIP (derate 10.00mW/°C above +70°C)	800mW
SO (derate 8.7mW/°C above +70°C)	695mW

Operating Temperature Ranges

MAX1488EC_D	0°C to +70°C
MAX1488EE_D	-40°C to +85°C
Storage Temperature Range	-65°C to +160°C
Lead Temperature (soldering, 10sec)	+300°C

Stresses beyond those listed under "Absolute Maximum Ratings" may cause permanent damage to the device. These are stress ratings only, and functional operation of the device at these or any other conditions beyond those indicated in the operational sections of the specifications is not implied. Exposure to absolute maximum rating conditions for extended periods may affect device reliability.

ELECTRICAL CHARACTERISTICS

(V_{CC} = 4.5V to 13.2V, V_{EE} = -4.5V to -13.2V, T_A = T_{MIN} to T_{MAX}, unless otherwise noted. Typical values are at T_A = +25°C.)

PARAMETER	SYMBOL	CONDITIONS	MIN	TYP	MAX	UNITS
DC CHARACTERISTICS						
Output Voltage High	V _{OH}	V _{CC} = -V _{EE} = 5.0V, R _L = 3kΩ	3.7	4.0		V
		V _{CC} = -V _{EE} = 6.5V, R _L = 3kΩ	5	5.4		
		V _{CC} = -V _{EE} = 12.0V, R _L = 3kΩ	10	10.5		
		V _{CC} = -V _{EE} = 13.2V, R _L = open			13.2	
Output Voltage Low	V _{OL}	V _{CC} = -V _{EE} = 5.0V, R _L = 3kΩ		-4.5	-3.7	V
		V _{CC} = -V _{EE} = 6.5V, R _L = 3kΩ		-5.8	-5	
		V _{CC} = -V _{EE} = 12.0V, R _L = 3kΩ		-10.8	-10	
		V _{CC} = -V _{EE} = 13.2V, R _L = open	-13.2			
Operating Voltage Range	V _{CC}		4.5		13.2	V
	V _{EE}		-13.2		-4.5	
Positive Supply Current	I _{CC}	No load		85	180	μA
Negative Supply Current	I _{EE}	No load	-180	-85		μA
Output Short-Circuit Current	I _{OS}	Output shorted to ground (Note 1)	±4	±20	±45	mA
Input High Voltage	V _{IH}		2.0			V
Input Low Voltage	V _{IL}				0.8	V
Input Current	I _{IN1}			0	±2	μA
Output Resistance	R _O	V _{CC} = V _{EE} = 0V V _{OL} ≤ 2.0V		300		Ω
TIMING CHARACTERISTICS (see Figure 1)						
Output Propagation Delay, Low to High	t _{PLH}	V _{CC} = 4.5V, V _{EE} = -4.5V, C _L = 50pF		2.4	3.5	μs
		V _{CC} = 9.0V, V _{EE} = -9.0V, C _L = 50pF		2.8	3.9	
		V _{CC} = 12.0V, V _{EE} = -12.0V, C _L = 50pF		3.1	4.2	
Output Propagation Delay, High to Low	t _{PHL}	V _{CC} = 4.5V, V _{EE} = -4.5V, C _L = 50pF		2.1	4.5	μs
		V _{CC} = 9.0V, V _{EE} = -9.0V, C _L = 50pF		2.4	5.1	
		V _{CC} = 12.0V, V _{EE} = -12.0V, C _L = 50pF		2.6	5.4	
Propagation Delay Skew, t _{PLH} - t _{PHL}	t _{SK}	V _{CC} = 4.5V, V _{EE} = -4.5V, C _L = 50pF		0.25		μs
		V _{CC} = 9.0V, V _{EE} = -9.0V, C _L = 50pF		0.42		
		V _{CC} = 12.0V, V _{EE} = -12.0V, C _L = 50pF		0.42		
ESD CHARACTERISTICS						
ESD Protection		Human Body Model		±15		kV
		IEC-1000-4-2 (Contact Discharge)		±6		
		IEC-1000-4-2 (Air-Gap Discharge)		±15		

±15kV ESD-Protected, Quad, Low-Power RS-232 Line Driver

MAX1488E

ELECTRICAL CHARACTERISTICS (continued)

($V_{CC} = 4.5V$ to $13.2V$, $V_{EE} = -4.5V$ to $-13.2V$, $T_A = T_{MIN}$ to T_{MAX} , unless otherwise noted. Typical values are at $T_A = +25^\circ C$.)

PARAMETER	SYMBOL	CONDITIONS	MIN	TYP	MAX	UNITS
Output Rise Time	t_{R1}	$C_L = 1500pF$, $R_L = 5k\Omega$, $V_{OUTPUT_}$ from $-3.3V$ to $3.3V$		850		ns
	t_{R2}	$C_L = 1500pF$, $R_L = 5k\Omega$, $V_{OUTPUT_}$ from $-3.0V$ to $3.0V$		740		
Output Fall Time	t_{F1}	$C_L = 1500pF$, $R_L = 5k\Omega$, $V_{OUTPUT_}$ from $-3.3V$ to $3.3V$		860		ns
	t_{F2}	$C_L = 1500pF$, $R_L = 5k\Omega$, $V_{OUTPUT_}$ from $-3.0V$ to $3.0V$		765		
Output Slew Rate	SR	$C_L = 15pF$ to $2500pF$, $R_L = 3k\Omega$ to $7k\Omega$, $V_{CC} = 12V$, $V_{EE} = -12V$, $T_A = +25^\circ C$, $V_{OUTPUT_}$ from $-3.0V$ to $3.0V$	4		30	V/ μs
Guaranteed Data Rate		$C_L = 15pF$ to $2500pF$, $R_L = 3k\Omega$ to $7k\Omega$, $V_{CC} = 12V$, $V_{EE} = -12V$, $T_A = +25^\circ C$	120			kbps

Note 1: The I_{OS} value is for one output at a time. If more than one output is shorted simultaneously, damage may occur.

2

Typical Operating Characteristics

($V_{CC} = 12V$, $V_{EE} = -12V$, $T_A = +25^\circ C$, unless otherwise noted.)

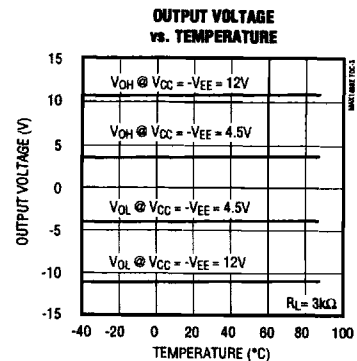
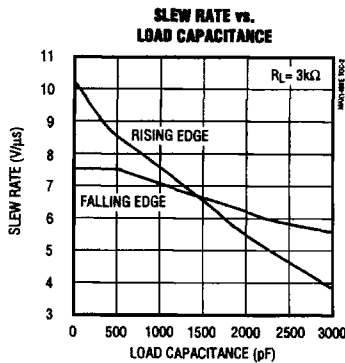
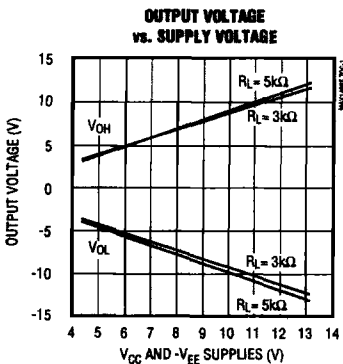

±15kV ESD-Protected, Quad, Low-Power RS-232 Line Driver

Pin Description

PIN	NAME	FUNCTION
1	V _{EE}	-4.5V to -13.2V Supply Voltage Input
2, 4, 5, 9, 10, 12, 13	INPUT ₋	Driver Inputs
3, 6, 8, 11	OUTPUT ₋	Driver Outputs
7	GND	Ground
14	V _{CC}	+4.5V to +13.2V Supply Voltage Input

Detailed Description

The MAX1488E provides ±15kV of ESD protection when operating or when powered down. After an ESD event, the MAX1488E will not latch up. Internal slew-rate-limiting circuitry eliminates the need for external capacitors. The MAX1488E has a guaranteed 120kbps data rate.

Outputs

Tables 1 and 2 describe the output states. The output voltage level is affected by both the load current and supply voltage, and is stable over temperature. Refer to the *Typical Operating Characteristics* to see how the output voltage varies with supply voltage, load capacitance, and temperature.

Table 1. Driver A Functions

INPUT A	OUTPUTA
H	L
L	H

Table 2. Driver B–D Functions

INPUT_1	INPUT_2	OUTPUT_
H	H	L
L	X	H
X	L	H

Inputs

The driver inputs determine the driver output states (Tables 1 and 2). Driver inputs B, C, and D have two inputs. **Connect unused inputs to ground or V_{CC}.**

±15kV ESD Protection

As with all Maxim devices, ESD-protection structures are incorporated on all pins to protect against electrostatic discharges encountered during handling and assembly. The MAX1488E driver outputs have extra protection against static electricity found in normal

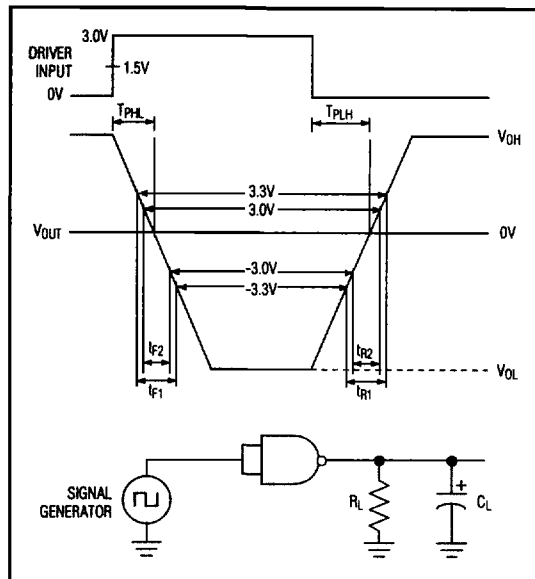

Figure 1. Slew-Rate Test Circuit and Timing Diagram

operation. Maxim's engineers developed state-of-the-art structures to protect these pins against ESD of ±15kV, without damage. After an ESD event, the MAX1488E keeps working without latchup.

ESD protection can be tested in various ways; the transmitter outputs are characterized for protection to the following:

- 1) ±15kV using the Human Body Model
- 2) ±6kV using the Contact-Discharge Method specified in IEC1000-4-2 (formerly IEC801-2)
- 3) ±15kV using the Air-Gap Method specified in IEC1000-4-2 (formerly IEC801-2).

ESD Test Conditions

ESD performance depends on a number of conditions. Contact Maxim for a reliability report that documents test setup, methodology, and results.

Human Body Model

Figure 2a shows the Human Body Model, and Figure 2b shows the current waveform it generates when discharged into a low impedance. This model consists of a 100pF capacitor charged to the ESD voltage of interest, which is then discharged into the test device through a 1.5kΩ resistor.

±15kV ESD-Protected, Quad, Low-Power RS-232 Line Driver

MAX1488E

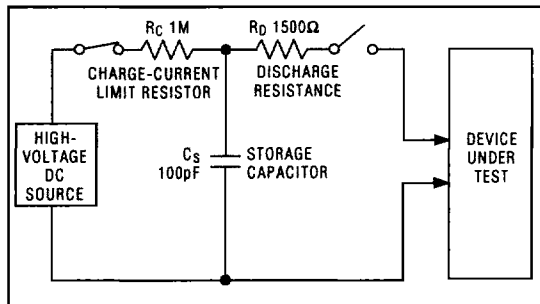

Figure 2a. Human Body ESD Test Model

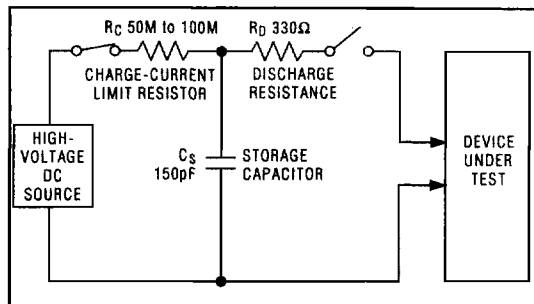

Figure 3a. IEC1000-4-2 ESD Test Model

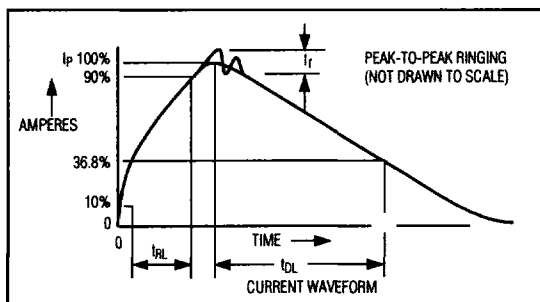

Figure 2b. Human Body Model Current Waveform

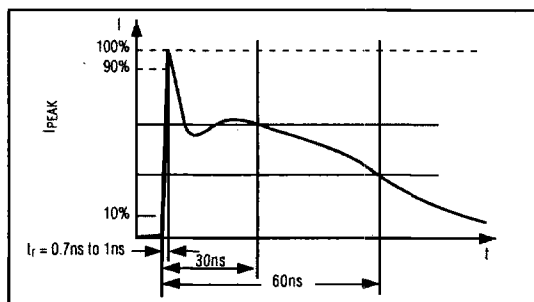

Figure 3b. IEC1000-4-2 ESD Generator Current Waveform

IEC1000-4-2

The IEC1000-4-2 standard covers ESD testing and performance of finished equipment; it does not specifically refer to integrated circuits. The MAX1488E helps you design equipment that meets Level 4 (the highest level) of IEC1000-4-2, without additional ESD-protection components.

The major difference between tests done using the Human Body Model and IEC1000-4-2 is higher peak current in IEC1000-4-2. Because series resistance is lower in the IEC1000-4-2 ESD test model (Figure 3a), the ESD withstand voltage measured to this standard is generally lower than that measured using the Human Body Model. Figure 3b shows the current waveform for the ±6kV IEC1000-4-2 Level 4 ESD Contact-Discharge test.

The Air-Gap test involves approaching the device with a charged probe. The Contact-Discharge method connects the probe to the device before the probe is energized.

Machine Model

The Machine Model for ESD testing uses a 200pF storage capacitor and zero-discharge resistance. Its objective is to mimic the stress caused by contact that occurs with handling and assembly during manufacturing. Of course, all pins (not just RS-232 inputs and outputs) require this protection during manufacturing. Therefore, the Machine Model is less relevant to the I/O ports than the Human Body Model and IEC1000-4-2.

Applications Information

Use proper layout to ensure other devices on your board are not damaged in an ESD strike. Currents as high as 60A can instantaneously pass into the ground, so it is important to minimize the ground-lead return path to the power supply. A separate return path to the power supply is recommended. Trace widths should be greater than 40 mils. VCC and VEE must be bypassed with 0.1μF capacitors as close to the part as possible to ensure maximum ESD protection.

2

±15kV ESD-Protected, Quad, Low-Power RS-232 Line Driver

MAX1488E

Chip Topography

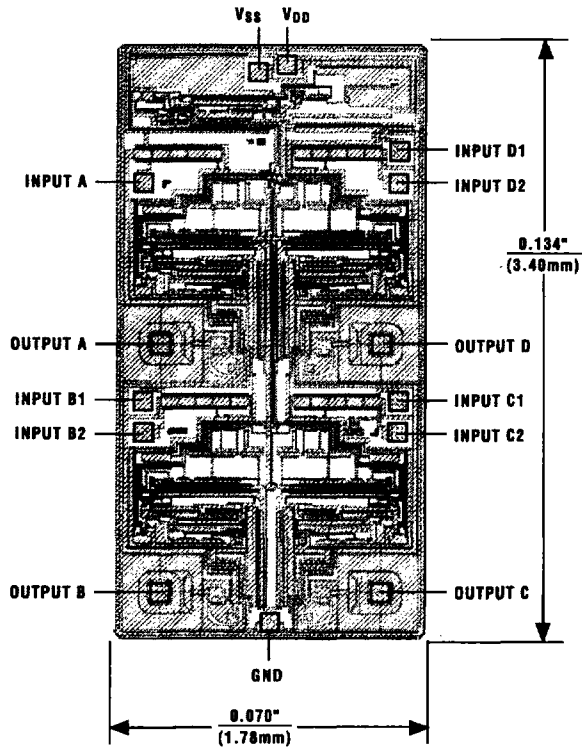

TRANSISTOR COUNT: 95
SUBSTRATE CONNECTED TO GND