

Distributed by:

**JAMECO**<sup>®</sup>  
ELECTRONICS

**www.Jameco.com ♦ 1-800-831-4242**

The content and copyrights of the attached  
material are the property of its owner.

Jameco Part Number 1209594

**MAXIM**

# ±15kV ESD-Protected, Quad, Low-Power RS-232 Line Receiver

## General Description

The MAX1489E quad, low-power line receiver is designed for EIA/TIA-232, EIA/TIA-562, and CCITT V.28 communications in harsh environments. Each receiver input is protected against ±15kV electrostatic discharge (ESD) shocks. These inputs have a ±25V range and feature hysteresis and time-domain filtering. The outputs are TTL and CMOS compatible. The MAX1489E has a 120kbps guaranteed data rate. Supply current is typically 350µA.

The MAX1489E is pin compatible with the MC1489, MC14C89, SN75189, SN75C189, DS1489, and DS14C89. It is available in 14-pin plastic DIP and SO packages.

## Applications

PC Motherboards

Modems

Interfacing Data Terminal Equipment (DTE) with Data Circuit-Terminating Equipment (DCE)

Equipment Meeting IEC1000-4-2 (formerly IEC801-2) or ±15kV ESD Protection

## Features

- ◆ **Enhanced ESD Protection:**
  - ±15kV—Human Body Model
  - ±8kV—IEC1000-4-2, Contact Discharge
  - ±15kV—IEC1000-4-2, Air-Gap Discharge
- ◆ **Latchup Free During an ESD Event**
- ◆ **Low 350µA Supply Current**
- ◆ **Input Hysteresis and Time-Domain Filtering Eliminate the Need for External Filtering**
- ◆ **Stable Input Thresholds**
- ◆ **Pin Compatible with MC1489, MC14C89, SN75189, SN75C189, DS1489, and DS14C89**

**MAX1489E**

## Ordering Information

PART	TEMP RANGE	PIN-PACKAGE
MAX1489ECPD	0°C to +70°C	14 Plastic DIP
MAX1489ECSO	0°C to +70°C	14 SO
MAX1489EC/D	0°C to +70°C	Dice*
MAX1489EEPD	-40°C to +85°C	14 Plastic DIP
MAX1489EEESO	-40°C to +85°C	14 SO

\* Dice are specified at  $T_A = +25^\circ\text{C}$ .

## Typical Operating Circuit

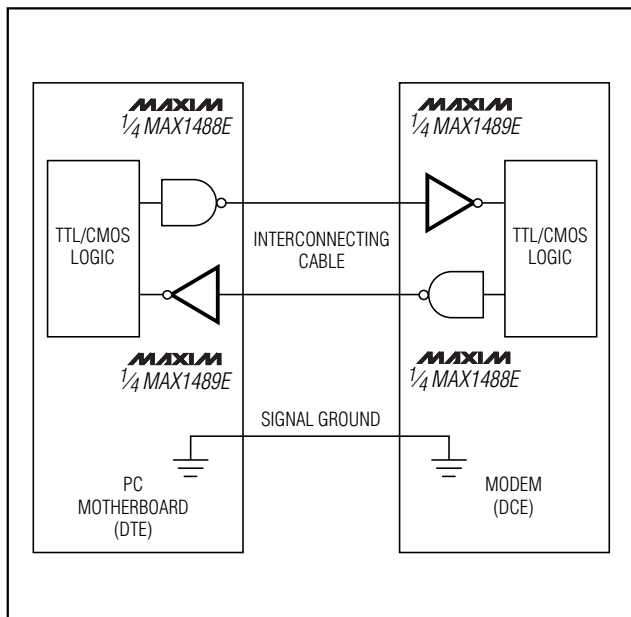

## Pin Configuration

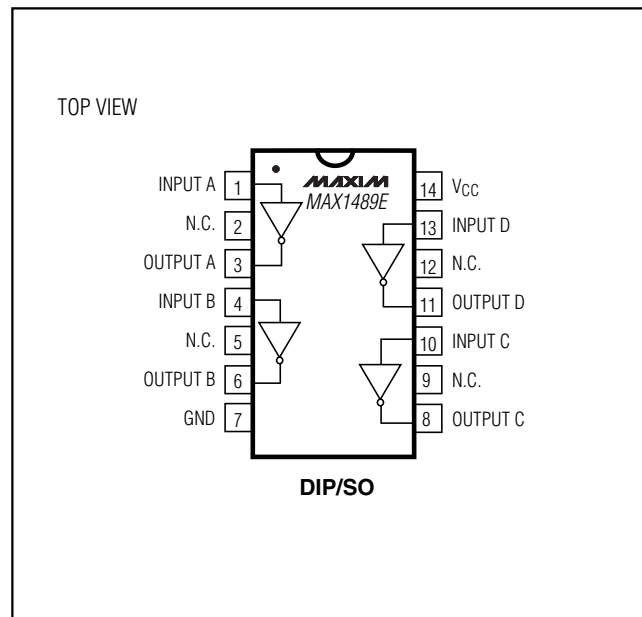
**MAXIM**

Maxim Integrated Products 1

For pricing, delivery, and ordering information, please contact Maxim/Dallas Direct! at 1-888-629-4642, or visit Maxim's website at [www.maxim-ic.com](http://www.maxim-ic.com).

# ±15kV ESD-Protected, Quad, Low-Power RS-232 Line Receiver

## ABSOLUTE MAXIMUM RATINGS

Supply Voltage (V <sub>CC</sub> ).....	+7V	Operating Temperature Ranges	
Input Voltage (V <sub>IN</sub> ).....	±30V	MAX1489EC_D .....	0°C to +70°C
Output Short-Circuit Current (Shorted to GND or V <sub>CC</sub> ) (Note 1) .....	Self Limiting	MAX1489EE_D .....	-40°C to +85°C
Continuous Power Dissipation (T <sub>A</sub> = +70°C)		Storage Temperature Range .....	-65°C to +160°C
Plastic DIP (derate 10.00mW/°C above +70°C) .....	800mW	Lead Temperature (soldering, 10s) .....	+300°C
SO (derate 8.7mW/°C above +70°C).....	695mW		

Stresses beyond those listed under "Absolute Maximum Ratings" may cause permanent damage to the device. These are stress ratings only, and functional operation of the device at these or any other conditions beyond those indicated in the operational sections of the specifications is not implied. Exposure to absolute maximum rating conditions for extended periods may affect device reliability.

## ELECTRICAL CHARACTERISTICS

(V<sub>CC</sub> = 5V ±10%, T<sub>A</sub> = T<sub>MIN</sub> to T<sub>MAX</sub>, unless otherwise noted. Typical values are at V<sub>CC</sub> = 5V, T<sub>A</sub> = +25°C.)

PARAMETER	SYMBOL	CONDITIONS	MIN	TYP	MAX	UNITS
<b>DC CHARACTERISTICS</b>						
Output Voltage High	V <sub>OH</sub>	V <sub>IN</sub> ≤ 0.4V	I <sub>OUT</sub> = -20μA	3.5	4.99	V
			I <sub>OUT</sub> = -3.2mA	2.5	4.41	
Output Voltage Low	V <sub>OL</sub>	V <sub>IN</sub> ≥ 2.4V, I <sub>OUT</sub> = 3.2mA		0.17	0.4	V
Output Short-Circuit Current (Note 1)	I <sub>OS</sub>	Shorted to GND	-35			mA
		Shorted to V <sub>CC</sub>			60	
Supply Current	I <sub>CC</sub>			260	600	μA
Input Voltage Range	V <sub>IN</sub>		-25		25	V
Input Voltage High	V <sub>IH</sub>		1.60	2.17	2.60	V
Input Voltage Low	V <sub>IL</sub>		0.75	1.06	1.30	V
Input Hysteresis	V <sub>HYST</sub>			1.11		V
Input Resistance	R <sub>IN</sub>		3.0	5.0	7.0	kΩ
<b>TIMING CHARACTERISTICS</b>						
Output Propagation Delay, Low to High	t <sub>PLH</sub>	Figure 1	1.38		4.0	μs
Output Propagation Delay, High to Low	t <sub>PHL</sub>	Figure 1	1.45		4.0	μs
Output Propagation Delay Skew,  t <sub>PLH</sub> - t <sub>PHL</sub>	t <sub>SKEW</sub>	Figure 1		70		ns
Output Transition Time	t <sub>TR</sub>	V <sub>OUT</sub> = 10% to 90%		35	120	ns
Input Noise Rejection	t <sub>N</sub>	Pulse amplitude = 5V (Note 2)		1.0		μs
Guaranteed Data Rate	DR		120	240		kbps
<b>ESD CHARACTERISTICS</b>						
ESD Protection		Human Body Model		±15		kV
		IEC1000-4-2 (Contact Discharge)		±8		
		IEC1000-4-2 (Air-Gap Discharge)		±15		

**Note 1:** Only one output may be shorted at a time.

**Note 2:** See Noise Pulse Rejection graph in *Typical Operating Characteristics* section.

# ±15kV ESD-Protected, Quad, Low-Power RS-232 Line Receiver

**MAX1489E**

## Typical Operating Characteristics

( $V_{CC} = 5V$ ,  $T_A = +25^\circ C$ , unless otherwise noted.)

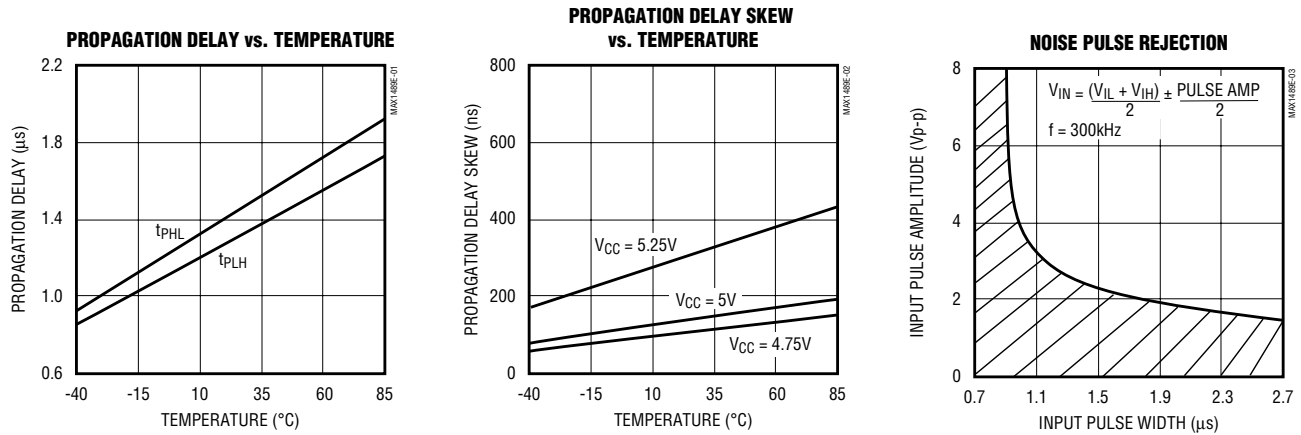

### Pin Description

PIN	NAME	FUNCTION
1, 4, 10, 13	INPUT_	Receiver Inputs
2, 5, 9, 12	N.C.	No Connect—not internally connected
3, 6, 8, 11	OUTPUT_	Receiver Outputs
7	GND	Ground
14	VCC	Supply Voltage

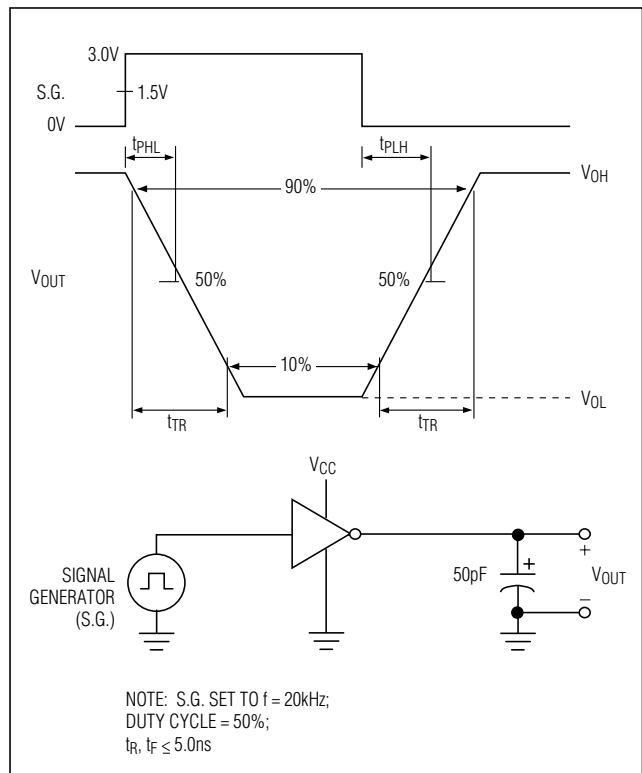

Figure 1. Timing Diagram

# ±15kV ESD-Protected, Quad, Low-Power RS-232 Line Receiver

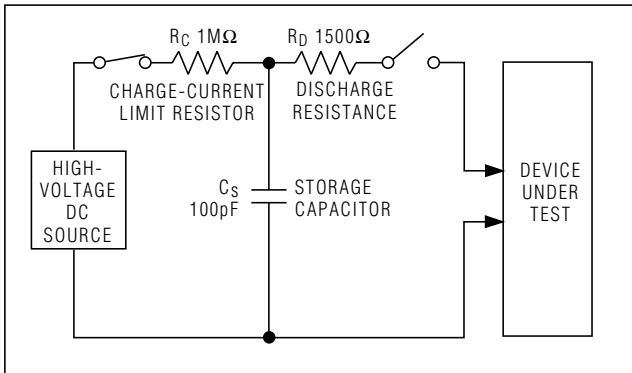

Figure 2a. Human Body ESD Test Model

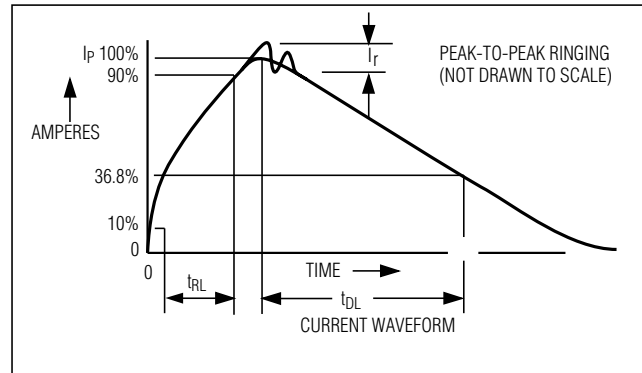

Figure 2b. Human Body Model Current Waveform

## Detailed Description

### ±15kV ESD Protection

As with all Maxim devices, ESD protection structures are incorporated on all pins to protect against electrostatic discharges encountered during handling and assembly. The MAX1489E receiver inputs have extra protection against static electricity found in normal operation. Maxim's engineers developed state-of-the-art structures to protect these pins against ESD of ±15kV without damage. After an ESD event, the MAX1489E keeps working without latchup.

ESD protection can be tested in various ways; the receiver inputs are characterized for protection to the following:

- 1) ±15kV using the Human Body Model
- 2) ±8kV using the Contact Discharge method specified in IEC1000-4-2 (formerly IEC801-2)
- 3) ±15kV using the Air-Gap Discharge method specified in IEC1000-4-2 (formerly IEC801-2).

### ESD Test Conditions

Contact Maxim for a reliability report that documents test setup, methodology, and results.

### Human Body Model

Figure 2a shows the Human Body Model, and Figure 2b shows the current waveform it generates when discharged into a low impedance. This model consists of a 100pF capacitor charged to the ESD voltage of interest, which is then discharged into the test device through a 1.5kΩ resistor.

### IEC1000-4-2

The IEC100-4-2 standard covers ESD testing and performance of finished equipment; it does not specifically refer to integrated circuits. The MAX1489E helps you design equipment that meets Level 4 (the highest level) of IEC1000-4-2, without additional ESD protection components.

The major difference between tests done using the Human Body Model and IEC1000-4-2 is higher peak current in IEC1000-4-2. Because series resistance is lower in the IEC1000-4-2 ESD test model (Figure 3a), the ESD withstand voltage measured to this standard is generally lower than that measured using the Human Body Model. Figure 3b shows the current waveform for the ±8kV IEC1000-4-2 Level 4 ESD Contact Discharge test.

The Air-Gap test involves approaching the device with a charged probe. The Contact Discharge method connects the probe to the device before the probe is energized.

# ±15kV ESD-Protected, Quad, Low-Power RS-232 Line Receiver

**MAX1489E**

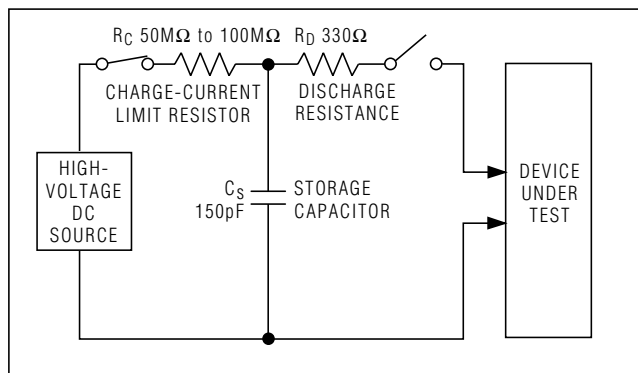

Figure 3a. IEC1000-4-2 ESD Test Model

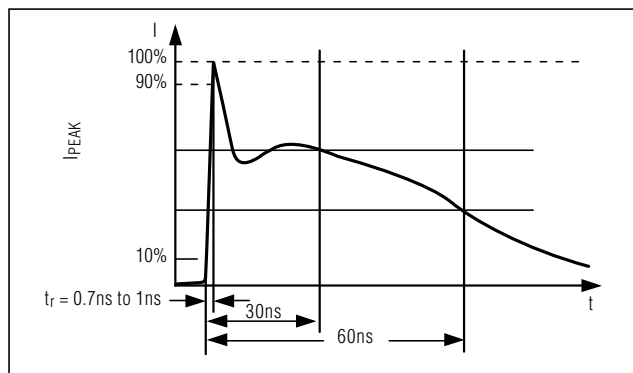

Figure 3b. IEC1000-4-2 ESD Generator Current Waveform

### Machine Model

The Machine Model for ESD testing uses a 200pF storage capacitor and zero-discharge resistance. Its objective is to mimic the stress caused by contact that occurs with handling and assembly during manufacturing. Of course, all pins (not just RS-232 inputs and outputs) require this protection during manufacturing. Therefore, the Machine Model is less relevant to the I/O ports than the Human Body Model and IEC1000-4-2.

### Applications Information

Use proper layout to ensure other devices on your board are not damaged in an ESD strike. Currents as high as 60A can instantaneously pass through the ground pin, so it is important to minimize the ground-lead return path to the power supply. A separate return path to the power supply is recommended. Trace widths should be greater than 40 mils.  $V_{CC}$  must be bypassed with 0.1 $\mu$ F capacitors as close to the part as possible to ensure maximum ESD protection.

# **$\pm 15\text{kV}$ ESD-Protected, Quad, Low-Power RS-232 Line Receiver**

**MAX1489E**

## **Chip Topography**

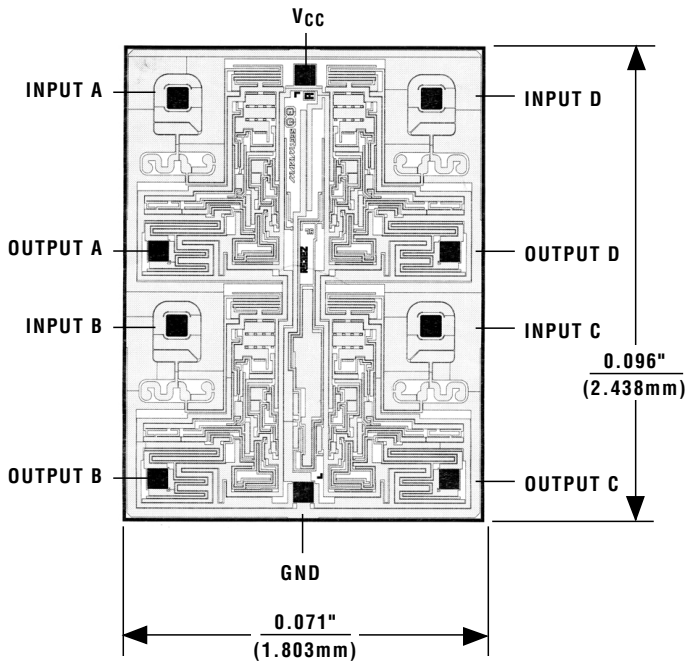

TRANSISTOR COUNT: 144

SUBSTRATE CONNECTED TO GND

# ±15kV ESD-Protected, Quad, Low-Power RS-232 Line Receiver

**MAX1489E**

## Package Information

(The package drawing(s) in this data sheet may not reflect the most current specifications. For the latest package outline information, go to [www.maxim-ic.com/packages](http://www.maxim-ic.com/packages).)

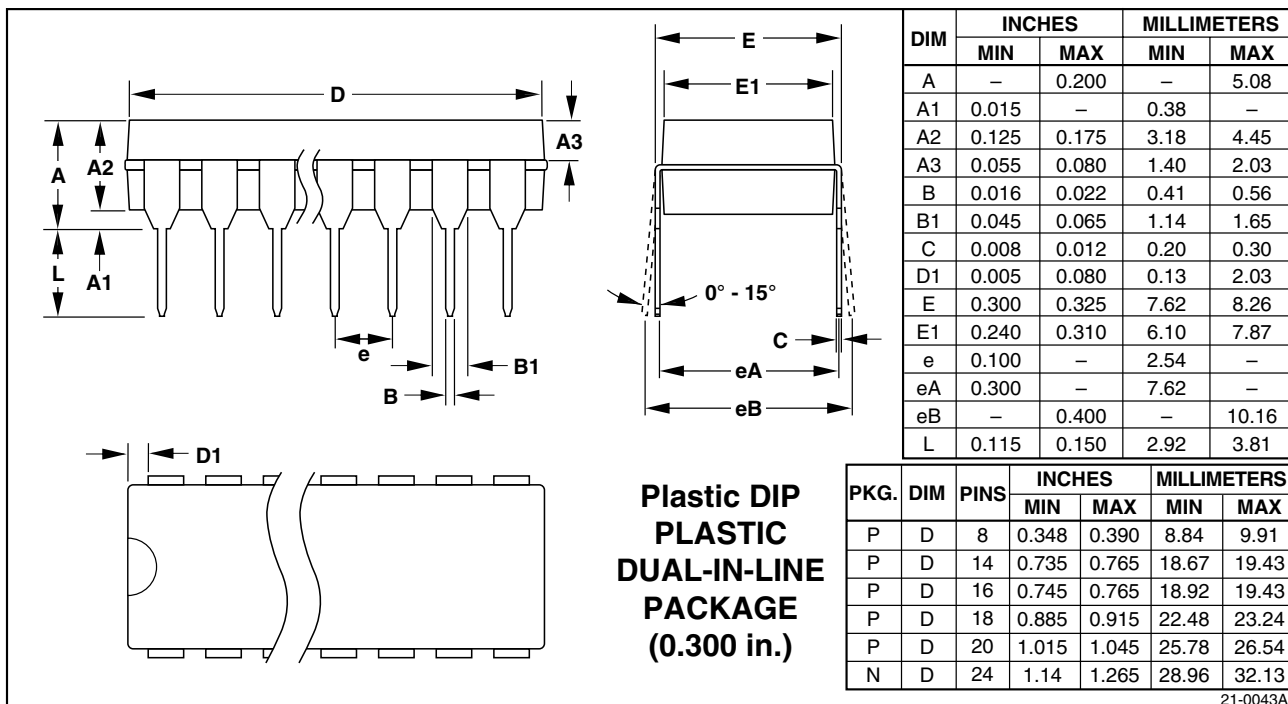

# ±15kV ESD-Protected, Quad, Low-Power RS-232 Line Receiver

## Package Information (continued)

(The package drawing(s) in this data sheet may not reflect the most current specifications. For the latest package outline information, go to [www.maxim-ic.com/packages](http://www.maxim-ic.com/packages).)

DIM	INCHES		MILLIMETERS	
	MIN	MAX	MIN	MAX
A	0.053	0.069	1.35	1.75
A1	0.004	0.010	0.10	0.25
B	0.014	0.019	0.35	0.49
C	0.007	0.010	0.19	0.25
E	0.150	0.157	3.80	4.00
e	0.050		1.27	
H	0.228	0.244	5.80	6.20
L	0.016	0.050	0.40	1.27

DIM	PINS	INCHES		MILLIMETERS	
		MIN	MAX	MIN	MAX
D	8	0.189	0.197	4.80	5.00
D	14	0.337	0.344	8.55	8.75
D	16	0.386	0.394	9.80	10.00

21-0041A

Maxim cannot assume responsibility for use of any circuitry other than circuitry entirely embodied in a Maxim product. No circuit patent licenses are implied. Maxim reserves the right to change the circuitry and specifications without notice at any time.

8 Maxim Integrated Products, 120 San Gabriel Drive, Sunnyvale, CA 94086 (408) 737-7600