



Dual, 4A/2A, 4MHz, Step-Down DC-DC Regulator with Dual LDO Controllers

General Description

The MAX15022 is a dual-output, pulse-width-modulated (PWM), step-down DC-DC regulator with dual LDO controllers. The device operates from 2.5V to 5.5V and each output can be adjusted from 0.6V to the input supply (V_{AVIN}). The MAX15022 delivers up to 4A (regulator 1) and 2A (regulator 2) of output current with two LDO controllers that can be used to drive two external PNP transistors to provide two additional outputs. This device offers the ability to adjust the switching frequency from 500kHz to 4MHz and provides the capability of optimizing the design in terms of size and performance.

The MAX15022 utilizes a voltage-mode control scheme with external compensation to provide good noise immunity and maximum flexibility in selecting inductor values and capacitor types. The dual switching regulators operate 180° out-of-phase, thereby reducing the RMS input ripple current and thus the size of the input bypass capacitor significantly.

The MAX15022 offers the ability to track (coincident or ratiometric) or sequence during power-up and power-down operation. When sequencing, it powers up glitch-free into a prebiased output.

Additional features include an internal undervoltage lockout with hysteresis and a digital soft-start/soft-stop for glitch-free power-up and power-down. Protection features include lossless cycle-by-cycle current limit, hiccup-mode output short-circuit protection, and thermal shutdown.

The MAX15022 is available in a space-saving, 5mm x 5mm, 28-pin TQFN-EP package and is specified for operation from -40°C to +125°C temperature range.

Applications

RFID Reader Cards
Power-over-Ethernet (PoE) IP Phones
Automotive Multimedia
Multivoltage Supplies
Networking/Telecom

Ordering Information

PART	TEMP RANGE	PIN-PACKAGE
MAX15022ATI+	-40°C to +125°C	28 TQFN-EP*

+Denotes a lead-free package.

*EP = Exposed pad.

Features

- ◆ 2.5V to 5.5V Input-Voltage Range
- ◆ Dual-Output Synchronous Buck Regulators
- ◆ Integrated Switches for 4A and 2A Output Currents
- ◆ 180° Out-Of-Phase Operation
- ◆ Output Voltage Adjustable from 0.6V to V_{AVIN}
- ◆ Two LDO Controllers
- ◆ Lossless, Cycle-by-Cycle Current Sensing
- ◆ External Compensation for Maximum Flexibility
- ◆ Digital Soft-Start and Soft-Stop for Tracking Applications
- ◆ Digital Soft-Start into a Prebiased Load for Sequencing Applications
- ◆ Sequencing or Coincident/Ratiometric Tracking
- ◆ Programmable Switching Frequency from 500kHz to 4MHz
- ◆ Thermal Shutdown and Hiccup-Mode Short-Circuit Protection
- ◆ 30μA Shutdown Current
- ◆ 100% Maximum Duty Cycle
- ◆ Space-Saving (5mm x 5mm) 28-Pin TQFN Package

Pin Configuration

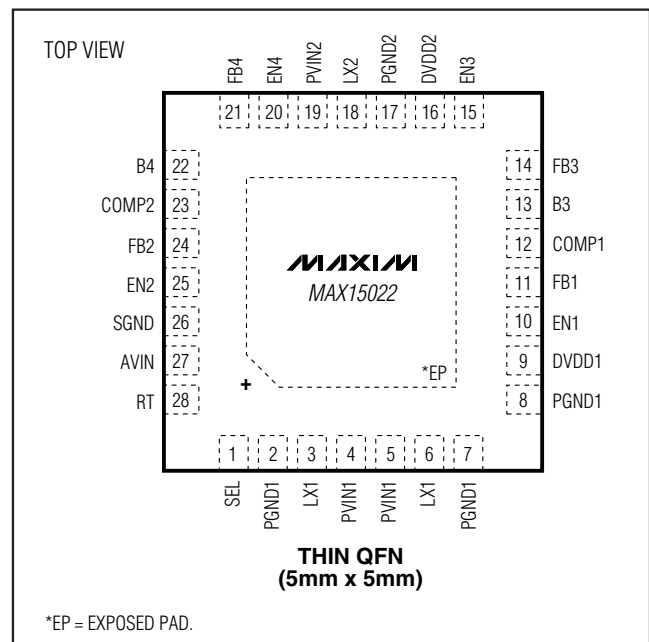

Dual, 4A/2A, 4MHz, Step-Down DC-DC Regulator with Dual LDO Controllers

ABSOLUTE MAXIMUM RATINGS

AVIN, PVIN_, B_, DVDD_, EN_, FB_, RT, SEL to SGND	-0.3V to +6V
COMP_ to SGND	-0.3V to (V _{AVIN} + 0.3V)
PGND_ to SGND	-0.3V to +0.3V
LX Current (Note 1)	
Regulator 1	6A
Regulator 2	3A
Current into Any Pin Other than PVIN_, LX_ and PGND_	±50mA

Continuous Power Dissipation (T _A = +70°C) 28-Pin TQFN (derate 34.5mW/°C above +70°C)	2758.6mW
Junction-to-Case Thermal Resistance (θ _{JC})(Note 2)	2°C/W
Junction-to-Ambient Thermal Resistance (θ _{JA})(Note 2)	29°C/W
Operating Temperature Range	-40°C to +125°C
Junction Temperature	+150°C
Storage Temperature Range	-60°C to +150°C
Lead Temperature (soldering, 10s)	+300°C

Note 1: LX has internal diodes to PGND_ and PVIN_. Applications that forward bias these diodes should take care not to exceed the IC's package power dissipation limits.

Note 2: Package thermal resistances were obtained using the method described in JEDEC specification JESD51-7, using a four-layer board. For detailed information on package thermal considerations see www.maxim-ic.com/thermal-tutorial.

Stresses beyond those listed under "Absolute Maximum Ratings" may cause permanent damage to the device. These are stress ratings only, and functional operation of the device at these or any other conditions beyond those indicated in the operational sections of the specifications is not implied. Exposure to absolute maximum rating conditions for extended periods may affect device reliability.

ELECTRICAL CHARACTERISTICS

(V_{AVIN} = V_{PVIN_} = V_{DVDD_} = 3.3V, V_{PGND_} = V_{SGND} = 0V, R_T = 25kΩ, and T_A = T_J = -40°C to +125°C, unless otherwise noted. Typical values are at T_A = +25°C.) (Note 3)

PARAMETER	SYMBOL	CONDITIONS	MIN	TYP	MAX	UNITS
SYSTEM SPECIFICATIONS						
Input-Voltage Range		V _{AVIN} = V _{PVIN1} = V _{PVIN2} = V _{DVDD1} = V _{DVDD2}	2.5		5.5	V
Undervoltage Lockout Threshold		AVIN rising	2.1	2.2	2.3	V
Undervoltage Lockout Hysteresis				0.12		V
Operating Supply Current		V _{EN_} = 1.3V, V _{FB_} = 0.8V		3.5	6	mA
Shutdown Supply Current		V _{EN_} = 0V		30	65	μA
PWM DIGITAL SOFT-START/SOFT-STOP						
Soft-Start/Soft-Stop Duration				4096		Clock Cycles
Reference Voltage Steps				64		Steps
PWM ERROR AMPLIFIERS						
FB1, FB2 Input Bias Current			-1		+1	μA
FB1, FB2 Voltage Set-Point			0.593	0.599	0.605	V
COMP1, COMP2 Voltage Range		I _{COMP_} = -250μA to +250μA	0.3		V _{AVIN} - 0.5	V
Error-Amplifier Open-Loop Gain				80		dB
Error-Amplifier Unity-Gain Bandwidth				12		MHz

Dual, 4A/2A, 4MHz, Step-Down DC-DC Regulator with Dual LDO Controllers

MAX15022

ELECTRICAL CHARACTERISTICS (continued)

($V_{AVIN} = V_{PVIN} = V_{DVDD} = 3.3V$, $V_{PGND} = V_{SGND} = 0V$, $R_T = 25k\Omega$, and $T_A = T_J = -40^\circ C$ to $+125^\circ C$, unless otherwise noted. Typical values are at $T_A = +25^\circ C$.) (Note 3)

PARAMETER	SYMBOL	CONDITIONS	MIN	TYP	MAX	UNITS
LDO CONTROLLERS						
FB3, FB4 Input Bias Current			-250		+250	nA
FB3, FB4 Voltage Set-point		5mA sink current, $V_{B-} = 0.5V$ to $5.5V$	0.585	0.600	0.615	V
FB3, FB4 to B3, B4 Transconductance		2.5mA to 10mA sink current, $V_{B-} = 0.5V$ to $5.5V$	0.56	1.20	2.30	S
B3, B4 Driver Sink Current		$V_{FB3}, V_{FB4} = 0V$, $V_{B-} = 0.5V$ to $5.5V$	20			mA
LDO Soft-Start Duration				512		Clock Cycles
LDO Reference Voltage Steps				64		Steps
POWER MOSFETS						
Regulator 1 p-Channel MOSFET R_{DSON}		$V_{DVDD1} = 5V$		50	90	$m\Omega$
Regulator 1 n-Channel MOSFET R_{DSON}		$V_{DVDD1} = 5V$		30	50	$m\Omega$
Regulator 1 Gate Charge		$V_{DVDD1} = 5V$		8		nC
Maximum LX1 RMS Current				4		A
Regulator 2 p-Channel MOSFET R_{DSON}		$V_{DVDD2} = 5V$		100	180	$m\Omega$
Regulator 2 n-Channel MOSFET R_{DSON}		$V_{DVDD2} = 5V$		60	100	$m\Omega$
Regulator 2 Gate Charge		$V_{DVDD2} = 5V$		4		nC
Maximum LX2 RMS Current				2		A
PWM CURRENT LIMIT AND HICCUP MODE						
Regulator 1 Peak Current Limit		$V_{PVIN} = V_{AVIN} = 3.3V$	4.5	4.9	5.3	A
		$V_{PVIN} = V_{AVIN} = 2.5V$	3.40	3.65	3.95	
Regulator 1 Valley Current Limit		$V_{PVIN} = V_{AVIN} = 3.3V$	4.0	5.0	5.65	A
		$V_{PVIN} = V_{AVIN} = 2.5V$	3.0	3.7	4.25	
Regulator 2 Peak Current Limit		$V_{PVIN} = V_{AVIN} = 3.3V$	2.25	2.45	2.65	A
		$V_{PVIN} = V_{AVIN} = 2.5V$	1.70	1.85	1.98	
Regulator 2 Valley Current Limit		$V_{PVIN} = V_{AVIN} = 3.3V$	2.0	2.5	2.83	A
		$V_{PVIN} = V_{AVIN} = 2.5V$	1.5	1.85	2.13	
Number of Cumulative Current-Limit Events to Hiccup	NCL			4		Clock Cycles
Number of Consecutive Noncurrent Limit Cycles to Clear NCL	NCLR			3		Clock Cycles
Hiccup Timeout	NHT			8192		Clock Cycles

Dual, 4A/2A, 4MHz, Step-Down DC-DC Regulator with Dual LDO Controllers

ELECTRICAL CHARACTERISTICS (continued)

($V_{AVIN} = V_{PVIN} = V_{DVDD} = 3.3V$, $V_{PGND} = V_{SGND} = 0V$, $R_T = 25k\Omega$, and $T_A = T_J = -40^\circ C$ to $+125^\circ C$, unless otherwise noted. Typical values are at $T_A = +25^\circ C$.) (Note 3)

PARAMETER	SYMBOL	CONDITIONS	MIN	TYP	MAX	UNITS
ENABLE/SEL						
EN_ Threshold		V_{EN_rising}	1.207	1.225	1.243	V
EN_ Hysteresis				0.12		V
EN_ Input Current			-2.5		+2.5	μA
SEL High Threshold			$0.85 \times V_{AVIN}$			V
SEL Low Threshold				$0.2 \times V_{AVIN}$		V
SEL Input Bias Current		Present only during startup	-100		+100	μA
OSCILLATOR						
Switching Frequency Range	f_{sw}	$f_{sw} = 4MHz \times [V_{RT}(V)/1.067(V)]$ (Note 4)			4000	kHz
Oscillator Accuracy		$f_{sw} \leq 1500kHz$	-6		+6	%
		$f_{sw} > 1500kHz$	-10		+10	
Phase Shift Between Regulators				180		Degrees
RT Current		$0 < V_{RT} < 1.067V$	31.30	32.00	32.58	μA
RT Voltage Range	V_{RT}		0.130		1.067	V
Minimum Controllable On-Time				60		ns
Minimum Controllable Off-Time				60		ns
PWM Ramp Amplitude				$V_{AVIN}/4$		V
PWM Ramp Valley				0.3		V
THERMAL SHUTDOWN						
Thermal Shutdown Temperature		Temperature rising		+160		$^\circ C$
Thermal Shutdown Hysteresis				15		$^\circ C$

Note 3: Specifications are 100% production tested at $T_A = +25^\circ C$ and $T_A = +125^\circ C$. Maximum and minimum specifications over temperature are guaranteed by design.

Note 4: When operating with $V_{AVIN} = 2.5V$, the maximum operating frequency should be derated to 3MHz.

Dual, 4A/2A, 4MHz, Step-Down DC-DC Regulator with Dual LDO Controllers

MAX15022

Typical Operating Characteristics

($V_{AVIN} = V_{DVDD1} = V_{DVDD2} = V_{PVIN1} = V_{PVIN2} = 5V$, $V_{OUT1} = 3.3V$, $V_{OUT2} = 1.5V$, $V_{PGND} = 0V$, $R_T = 16.5k\Omega$, $T_A = +25^\circ C$, unless otherwise noted.)

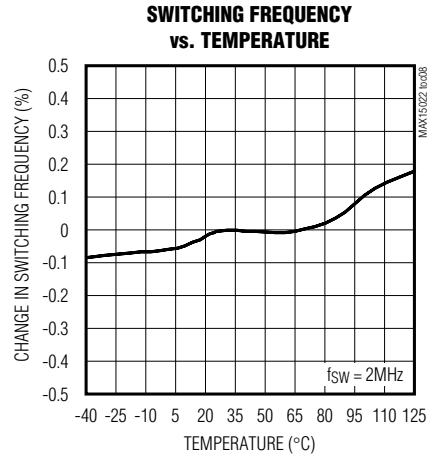
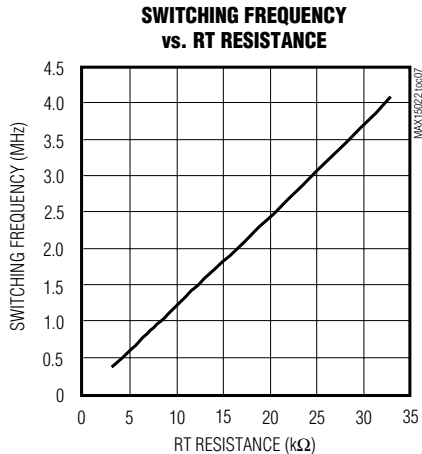
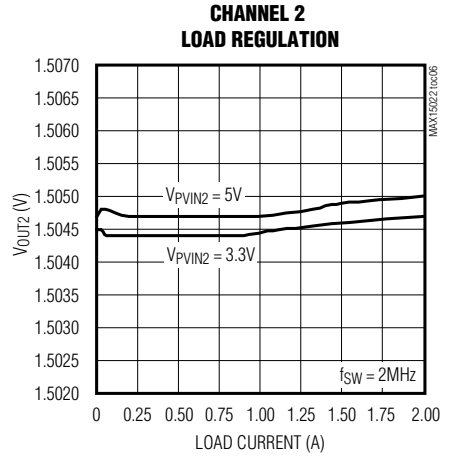
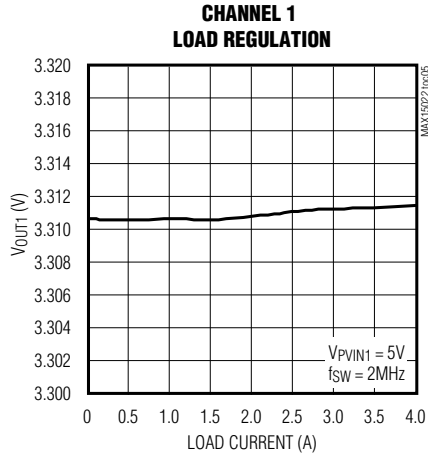
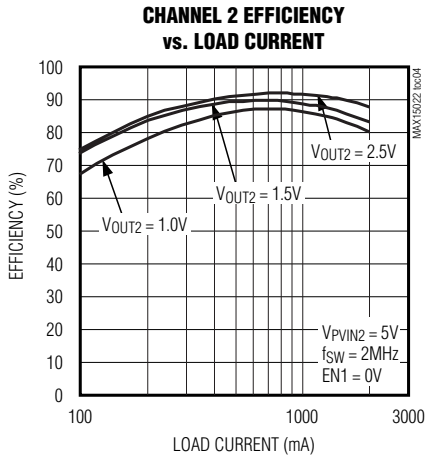
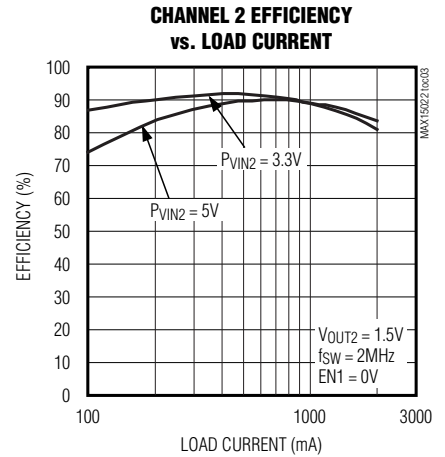
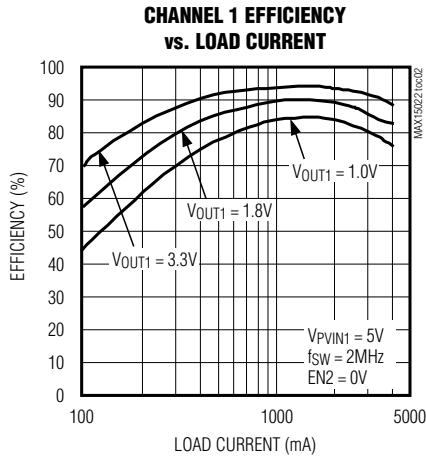
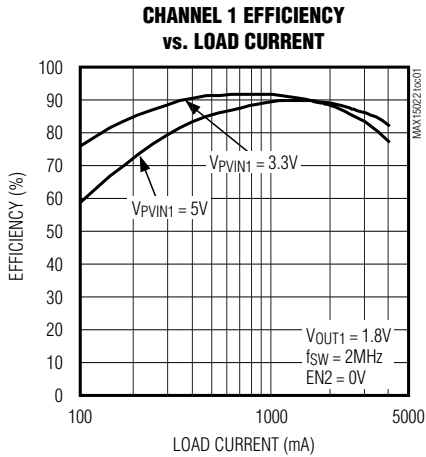

Dual, 4A/2A, 4MHz, Step-Down DC-DC Regulator with Dual LDO Controllers

Typical Operating Characteristics (continued)

($V_{AVIN} = V_{DVDD1} = V_{DVDD2} = V_{PVIN1} = V_{PVIN2} = 5V$, $V_{OUT1} = 3.3V$, $V_{OUT2} = 1.5V$, $V_{PGND_} = 0V$, $R_T = 16.5k\Omega$, $T_A = +25^\circ C$, unless otherwise noted.)

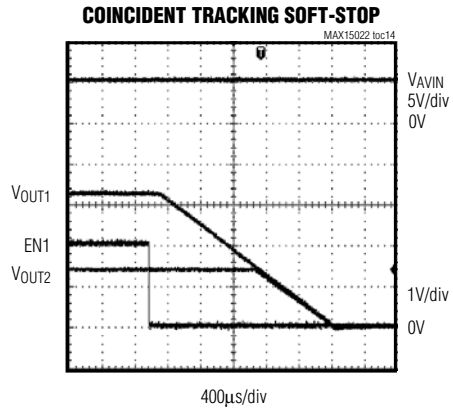
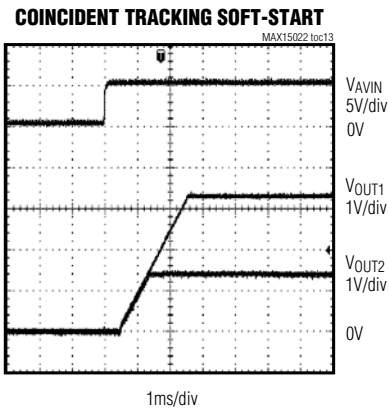
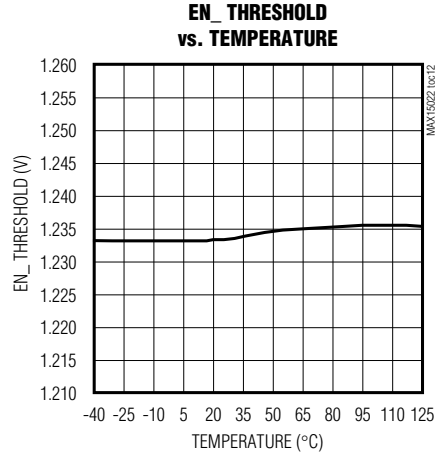
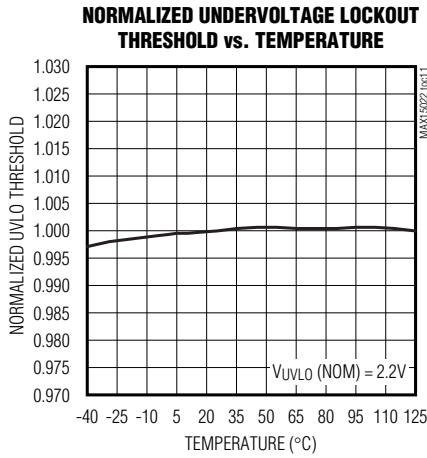
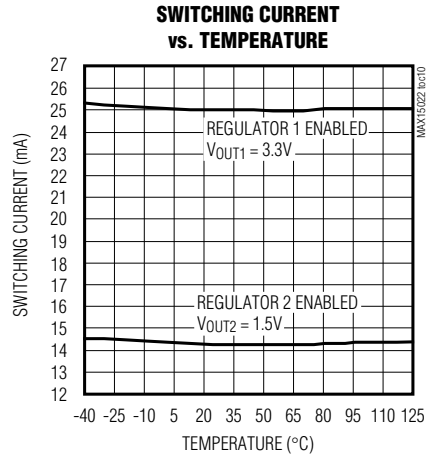
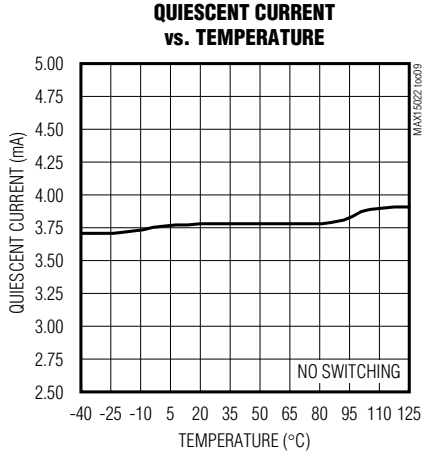

Dual, 4A/2A, 4MHz, Step-Down DC-DC Regulator with Dual LDO Controllers

MAX15022

Typical Operating Characteristics (continued)

($V_{AVIN} = V_{DVDD1} = V_{DVDD2} = V_{PVIN1} = V_{PVIN2} = 5V$, $V_{OUT1} = 3.3V$, $V_{OUT2} = 1.5V$, $V_{PGND_} = 0V$, $R_T = 16.5k\Omega$, $T_A = +25^\circ C$, unless otherwise noted.)

CHANNEL 1 LOAD STEP RESPONSE

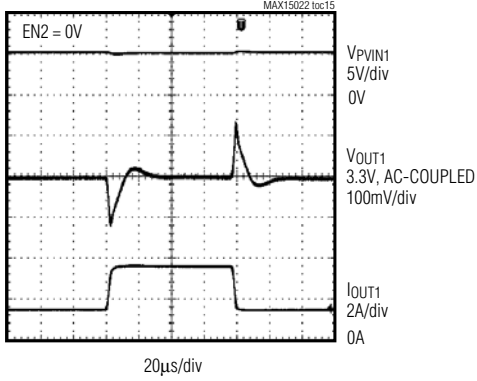

CHANNEL 1 LOAD STEP RESPONSE

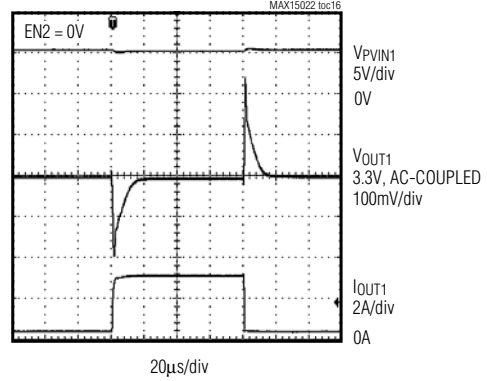

CHANNEL 2 LOAD STEP RESPONSE

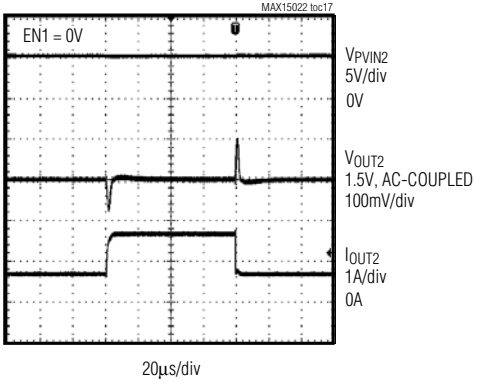

CHANNEL 2 LOAD STEP RESPONSE

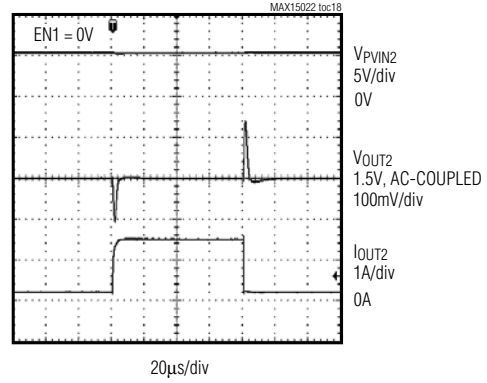

180° OUT-OF-PHASE OPERATION

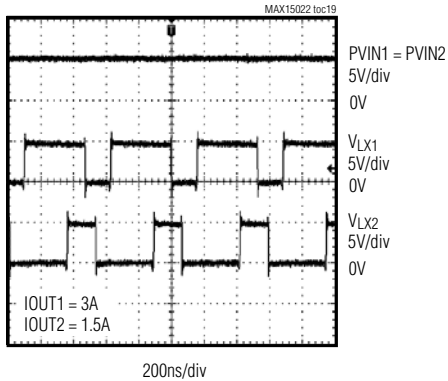

CHANNEL 3 AND CHANNEL 4 OUTPUT-VOLTAGE DEVIATION vs. LOAD CURRENT

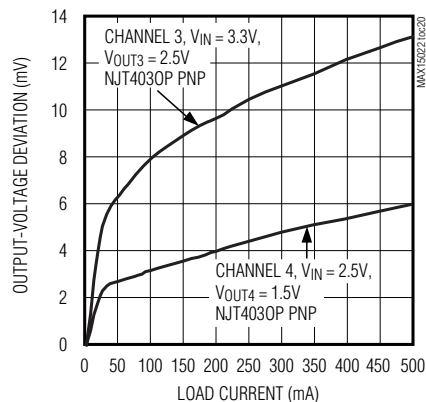

Dual, 4A/2A, 4MHz, Step-Down DC-DC Regulator with Dual LDO Controllers

Typical Operating Characteristics (continued)

($V_{AVIN} = V_{DVDD1} = V_{DVDD2} = V_{PVIN1} = V_{PVIN2} = 5V$, $V_{OUT1} = 3.3V$, $V_{OUT2} = 1.5V$, $V_{PGND_} = 0V$, $R_T = 16.5k\Omega$. $T_A = +25^\circ C$, unless otherwise noted.)

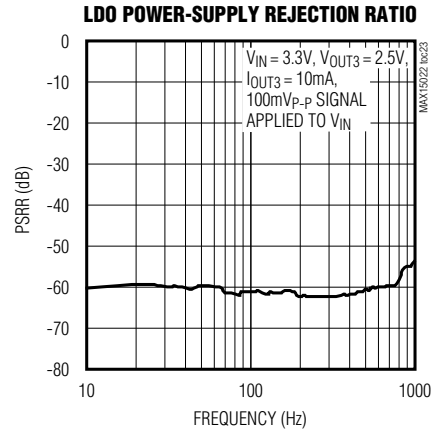
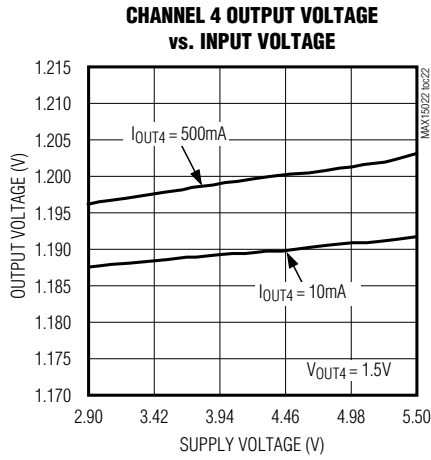
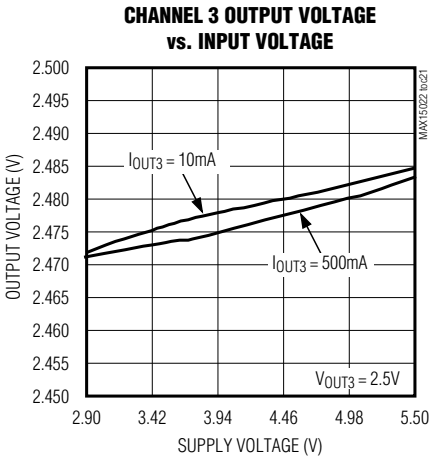

Pin Description

PIN	NAME	FUNCTION
1	SEL	Track/Sequence Select Input. Connect SEL to SGND to configure the device as a sequencer. Connect SEL to AVIN for tracking with output 1 as the master. Leave SEL unconnected for tracking with output 2 as the master. Use the output with the higher voltage as the master and the output with the lower voltage as the slave.
2, 7, 8	PGND1	Power Ground Connection for Regulator 1. Connect the negative terminals of the input and output filter capacitors to PGND1. Connect PGND1 externally to SGND at a single point, typically at the negative terminal of the input bypass capacitor.
3, 6	LX1	Inductor Connection for Regulator 1. LX1 is the drain connection of the internal high-side p-channel MOSFET and the drain connection of the internal synchronous n-channel MOSFET for regulator 1.
4, 5	PVIN1	Input Supply Voltage for Regulator 1. Connect PVIN1 to an external voltage source from 2.5V to 5.5V. Bypass PVIN1 to PGND1 with a 1 μ F (min) ceramic capacitor.
9	DVDD1	Switch Driver Supply for Regulator 1. Connect externally to PVIN1.
10	EN1	Enable Input for Regulator 1. When configured as a sequencer, EN1 must exceed 1.225V (typ) for the PWM controller to begin regulating output 1. When configured as a tracker, connect EN1 to the center tap of a resistive divider from the regulator 2 output.
11	FB1	Feedback Regulation Point for Regulator 1. Connect FB1 to the center tap of a resistive divider from the regulator 1 output to SGND to set the output voltage. The FB1 voltage regulates to 0.6V (typ).
12	COMP1	Error-Amplifier Output for Regulator 1. Connect COMP1 to the compensation feedback network.

Dual, 4A/2A, 4MHz, Step-Down DC-DC Regulator with Dual LDO Controllers

Pin Description (continued)

MAX15022

PIN	NAME	FUNCTION
13	B3	Transconductance Amplifier Open-Drain Output for LDO Controller 3. Connect B3 to the base of an external PNP transistor to regulate output 3.
14	FB3	Feedback Regulation Point for LDO Controller 3. Connect to the center tap of a resistive divider from the output 3 to SGND to set the output voltage. The FB3 voltage regulates to 0.6V (typ).
15	EN3	LDO Enable Input for LDO Controller 3. EN3 must exceed 1.225V (typ) for the LDO controller to begin regulating output 3.
16	DVDD2	Switch Driver Supply for Regulator 2. Connect externally to PVIN2.
17	PGND2	Power Ground Connection for Regulator 2. Connect the negative terminals of the input and output filter capacitors to PGND2. Connect PGND2 externally to SGND at a single point, typically at the negative terminal of the input bypass capacitor.
18	LX2	Inductor Connection for Regulator 2. LX2 is the drain connection of the internal high-side p-channel MOSFET and the drain connection of the internal synchronous n-channel MOSFET for Regulator 2.
19	PVIN2	Input Supply Voltage for Regulator 2. Connect to an external voltage source from 2.5V to 5.5V. Bypass PVIN2 to PGND2 with a 1 μ F (min) ceramic capacitor.
20	EN4	LDO Enable Input for LDO Controller 4. EN4 must exceed 1.225V (typ) for the LDO controller to begin regulating output 4.
21	FB4	Feedback Regulation Point for LDO Controller 4. Connect to the center tap of a resistive divider from output 4 to SGND to set the output voltage. The FB4 voltage regulates to 0.6V (typ).
22	B4	Transconductance Amplifier Open-Drain Output for LDO Controller 4. Connect B4 to the base of an external PNP transistor to regulate output 4.
23	COMP2	Error-Amplifier Output for Regulator 2. Connect COMP2 to the compensation feedback network.
24	FB2	Feedback Regulation Point for Regulator 2. Connect to the center tap of a resistive divider from the regulator 2 output to SGND to set the output voltage. The FB2 voltage regulates to 0.6V (typ).
25	EN2	Enable Input for Regulator 2. When configured as a sequencer, EN2 must exceed 1.225V (typ) for the PWM controller to begin regulating output 1. When configured as a tracker, connect EN2 to the center tap of a resistive divider from the regulator 1 output.
26	SGND	Signal Ground. Connect SGND to PGND_ at a single point, typically near the negative terminal of the input bypass capacitor.
27	AVIN	Input Voltage. Bypass AVIN to SGND with a 100nF (min) ceramic capacitor.
28	RT	Oscillator Timing Resistor Connection. Connect a 4.2k Ω to 33k Ω resistor from RT to SGND to program the switching frequency from 500kHz to 4MHz.
—	EP	Exposed Paddle. Connect EP to a large copper plane at SGND potential to improve thermal dissipation. Do not use as the main SGND connection.

Dual, 4A/2A, 4MHz, Step-Down DC-DC Regulator with Dual LDO Controllers

Functional Diagrams

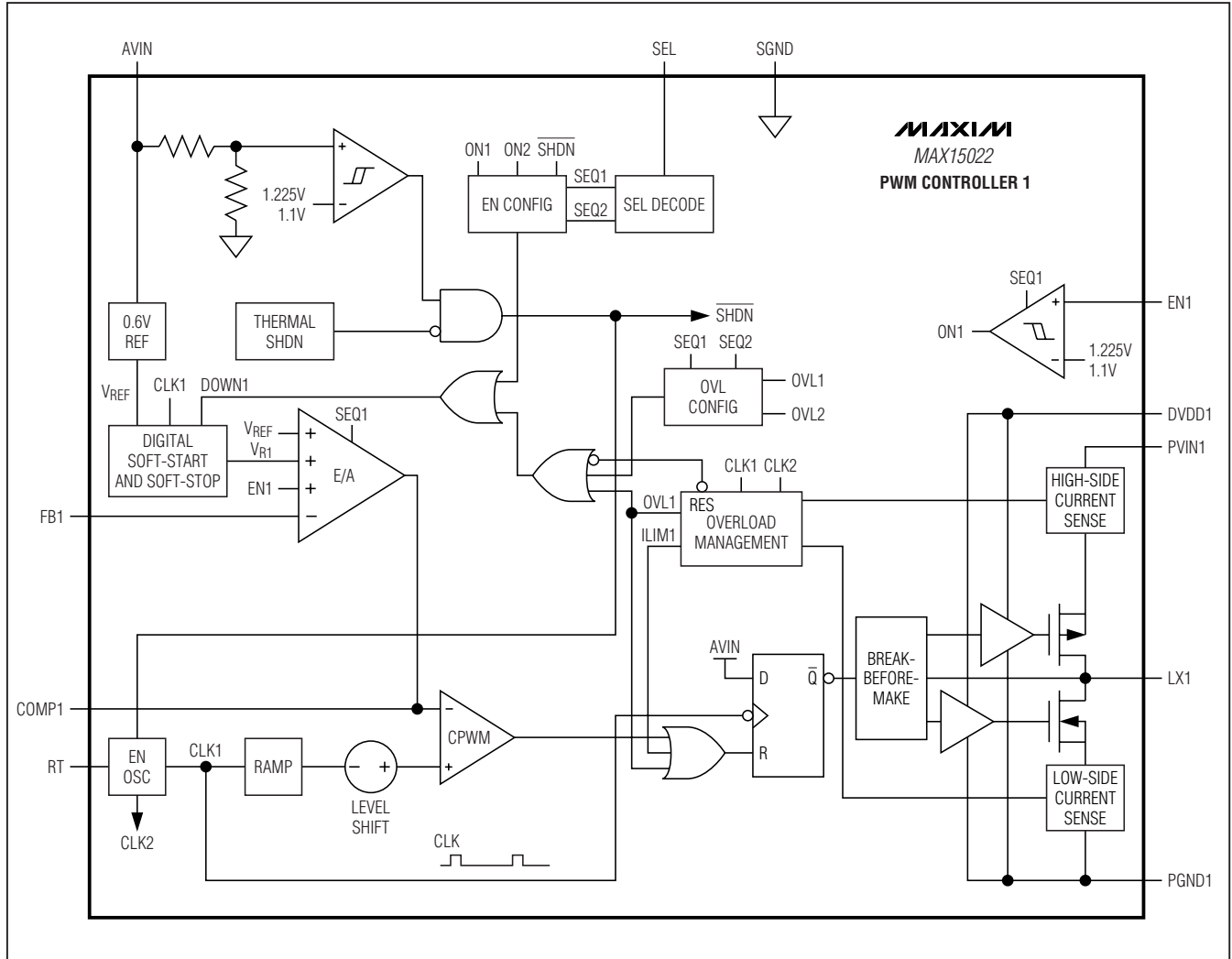

Dual, 4A/2A, 4MHz, Step-Down DC-DC Regulator with Dual LDO Controllers

Functional Diagrams (continued)

MAX15022

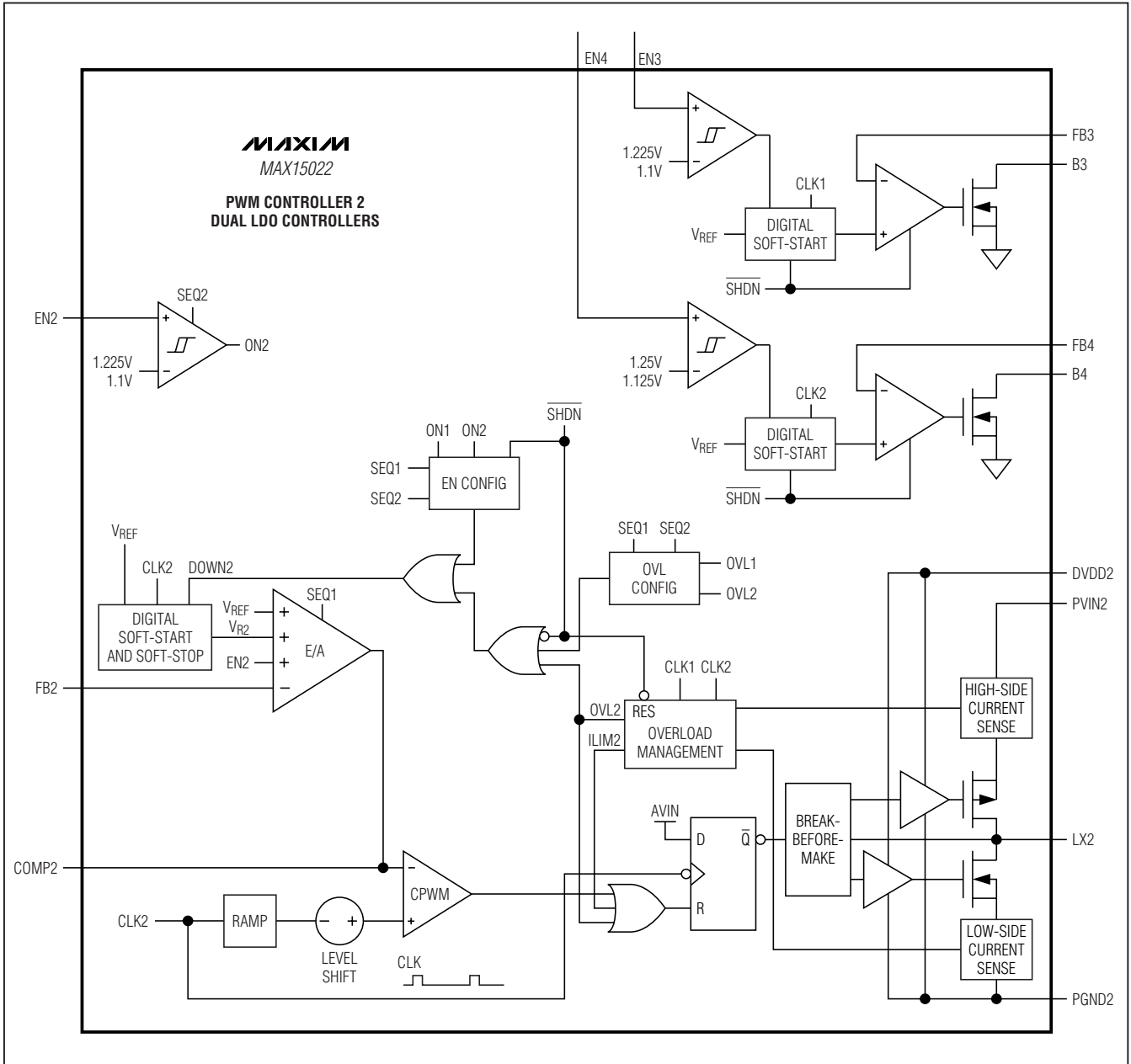

Dual, 4A/2A, 4MHz, Step-Down DC-DC Regulator with Dual LDO Controllers

Detailed Description

The MAX15022 incorporates dual-output, PWM, step-down, DC-DC regulators and dual LDO controllers with tracking and sequencing options. The device operates over the input-voltage range of 2.5V to 5.5V. Each PWM regulator provides an adjustable output down to 0.6V and delivers up to 4A (regulator 1) and 2A (regulator 2) of load current. The high switching frequency (up to 4MHz) and integrated power switches optimize the MAX15022 for high-performance and small-size power management solutions.

Each of the MAX15022 PWM regulator sections utilizes a voltage-mode control scheme for good noise immunity and offers external compensation allowing for maximum flexibility with a wide selection of inductor values and capacitor types. The device operates at a fixed switching frequency that is programmable from 500kHz to 4MHz with a single resistor. Operating the regulators with 180° out-of-phase clocking, and at frequencies up to 4MHz, significantly reduces the RMS input ripple current. The resulting peak input current reduction (and increase in the ripple frequency) significantly reduces the required amount of input bypass capacitance.

The MAX15022 provides coincident tracking, ratiometric tracking, or sequencing to allow tailoring of power-up/power-down sequence depending on the system requirements. When sequencing, it powers up glitch-free into a prebiased output. The MAX15022 features two LDO controllers for external PNP pass transistors to provide two additional outputs.

The MAX15022 includes internal undervoltage lockout with hysteresis, digital soft-start/soft-stop for glitch-free power-up and power-down. Protection features include lossless, cycle-by-cycle current limit, hiccup-mode output short-circuit protection, and thermal shutdown.

Undervoltage Lockout (UVLO)

The supply voltage (V_{AVIN}) must exceed the default UVLO threshold before any operation starts. The UVLO circuitry keeps the MOSFET drivers, oscillator, and all the internal circuitry shut down to reduce current consumption. The UVLO rising threshold is 2.2V (typ) with a 120mV (typ) hysteresis.

Digital Soft-Start/Soft-Stop

The MAX15022 soft-start feature allows the load voltage to ramp up in a controlled manner, eliminating output-voltage overshoot. Soft-start begins after V_{AVIN} exceeds the undervoltage lockout threshold and the enable input is above 1.225V (typ). The soft-start circuitry ramps up the reference voltage, controlling the rate of rise of the output voltage, and reducing input

surge currents during startup. The soft-start duration is 4096 clock cycles. The output voltage is incremented through 64 equal steps. The output reaches regulation when soft-start is completed, regardless of the output capacitance and load.

For tracking applications, soft-stop commences when the enable input falls below 1.1V (typ). The soft-stop circuitry ramps down the reference voltage controlling the output-voltage rate of fall. The output voltage is decremented through 64 equal steps in 4096 clock cycles.

Oscillator

Use an external resistor at R_T to program the MAX15022 switching frequency from 500kHz to 4MHz. Calculate the appropriate resistor value at R_T for the desired output switching frequency (f_{sw}):

$$R_T[\text{k}\Omega] = \frac{f_{sw}[\text{kHz}] \times 1.067[\text{V}]}{32[\mu\text{A}] \times 4[\text{MHz}]}$$

Tracking/Sequencing

The MAX15022 features coincident/ratiometric tracking and sequencing (see Figure 1). Connect SEL to ground to configure the device as a sequencer. Connect SEL to $AVIN$ for tracking with output 1 as the master. Leave SEL unconnected for tracking with output 2 as the master. Assign the output with the higher voltage as the master.

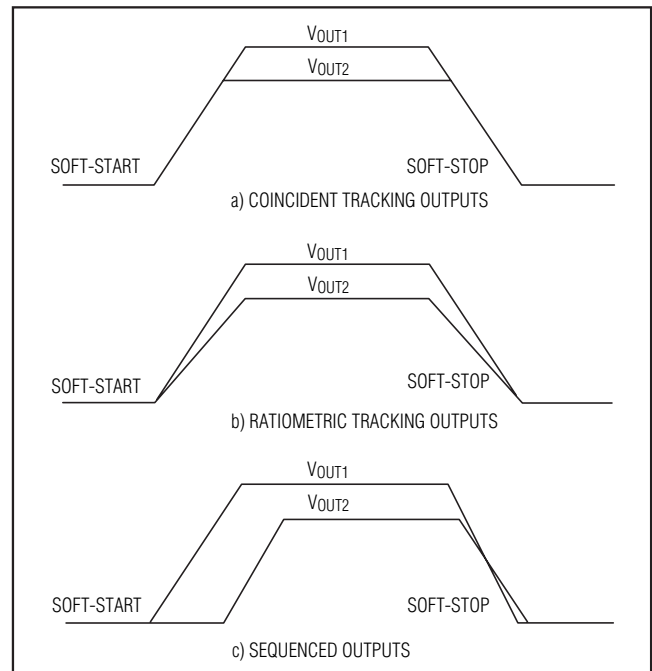

Figure 1. Graphical Representation of Coincident Tracking, Ratiometric Tracking, and Sequencing

Dual, 4A/2A, 4MHz, Step-Down DC-DC Regulator with Dual LDO Controllers

Coincident/Ratiometric Tracking

The enable inputs in conjunction with digital soft-start and soft-stop provide coincident/ratiometric tracking. Track an output voltage by connecting a resistive divider from the output being tracked to its enable input. For example, for V_{OUT2} to coincidentally track V_{OUT1} , connect the same resistive divider used for FB2, from V_{OUT1} to EN2 to SGND (see Figure 2).

Track ratiometrically by connecting EN_ to SGND. This synchronizes the soft-start and soft-stop of all the regulator references, and hence their respective output voltages will track ratiometrically (see Figure 2).

When the MAX15022 regulators are configured as voltage trackers, output short-circuit fault conditions at either master or slave output are handled carefully—neither the master nor slave output will remain energized

when the other output is shorted to ground. When the slave is shorted and enters into hiccup mode, the master will soft-stop. When the master is shorted and the part enters into hiccup mode, the slave will ratiometrically soft-stop. Coming out of hiccup mode, both outputs will soft-start coincidentally or ratiometrically depending on their initial configuration. During the thermal shutdown or power-off when the input falls below its UVLO, the output voltages track down depending on the respective output capacitance and load.

See Figure 1 for a graphical representation of coincident/ratiometric tracking.

Sequencing

When sequencing, the voltage at the enable inputs must exceed 1.225V (typ) for each PWM controller to start (see Figure 1c).

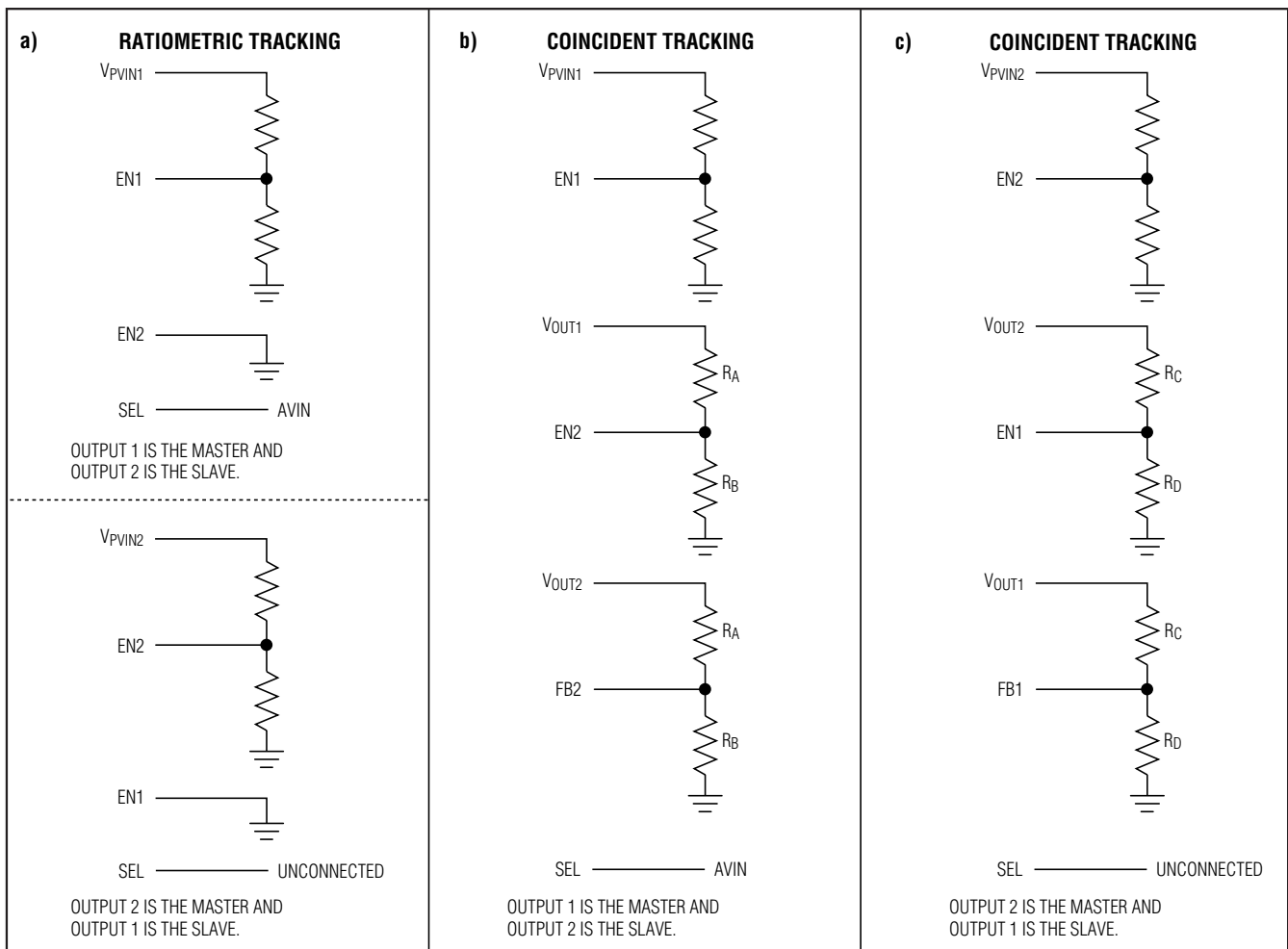

Figure 2. Ratiometric Tracking and Coincident Tracking Configurations

Dual, 4A/2A, 4MHz, Step-Down DC-DC Regulator with Dual LDO Controllers

Error Amplifier

The output of the internal voltage-mode error amplifier (COMP_) is provided for frequency compensation (see the *Compensation Design Guidelines* section). FB_ is the inverting input of the error amplifier. The error amplifier has an 80dB open-loop gain and a 12MHz gain bandwidth (GBW) product.

Output Short-Circuit Protection (Hiccup Mode)

The MAX15022 features lossless, high-side peak current limit and low-side, valley current limit. At short duty cycles, both limits are active. At high duty cycles, only the high-side peak current limit is active. Either limit causes the hiccup mode counter (N_{CL}) to increment.

For duty cycles less than 50%, the low-side valley current limit is active. Once the high-side MOSFET turns off, the voltage across the low-side MOSFET is monitored. If this voltage does not exceed the current-limit threshold at the end of the cycle, the high-side MOSFET turns on normally at the start of the next cycle. If the voltage exceeds the current-limit threshold just before the beginning of a new PWM cycle, the controller skips that cycle. During severe overload or short-circuit conditions, the switching frequency of the device appears to decrease because the on-time of the low-side MOSFET extends beyond a clock cycle.

If the current-limit threshold is exceeded for more than four cumulative clock cycles (N_{CL}), the device shuts down for 8192 clock cycles (hiccup timeout) and then restarts with a soft-start sequence. If three consecutive cycles pass without a current-limit event, the count of N_{CL} is cleared (see Figure 3). Hiccup mode protects the device against a continuous output short circuit.

The internal current limit is constant from 5.5V down to 3V and decreases linearly by 50% from 3V to 2V. See the *Electrical Characteristics* table.

Thermal-Overload Protection

The MAX15022 features an integrated thermal-overload protection with temperature hysteresis. Thermal-overload protection limits the die temperature of the device and protects it in the event of an extended thermal fault condition. When the die temperature exceeds +160°C, an internal thermal sensor shuts down the device, turning off the internal power MOSFETs and allowing the die to cool. After the die temperature falls by +15°C (typ), the device restarts with a soft-start sequence.

Startup into a Prebiased Output (Sequencing Mode)

In sequencing mode, the regulators start with minimal glitch into a prebiased output and soft-stop is disabled.

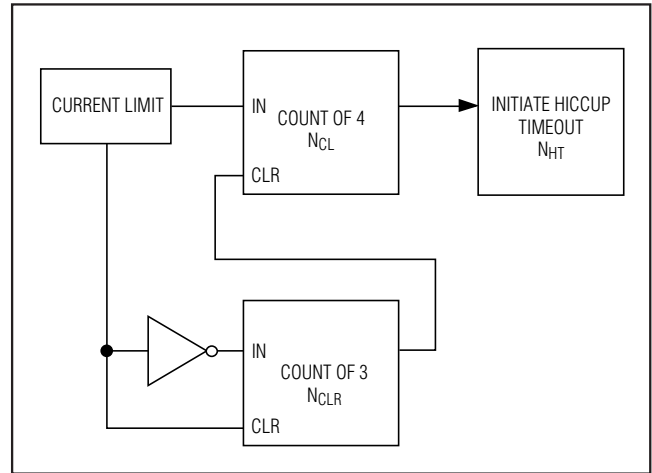

Figure 3. Hiccup-Mode Block Diagram

During soft-start, both switches are kept off until the PWM comparator commands its first PWM pulse. Until then, the converters do not sink current from the outputs. The first PWM pulse occurs when the ramping reference voltage increases above the FB_ voltage.

LDO Controllers

The MAX15022 provides two additional LDO controllers to drive external PNP pass transistors. Connect the emitter of each PNP pass transistor to either the input supply or one of the controller 1 or 2 outputs. Each LDO controller features an independent enable input and digital soft-start. Connect FB3 and FB4 to the center tap of a resistive divider from the output of the desired LDO controller to SGND to set the output voltage.

PWM Controllers Design Procedure

Setting the Switching Frequency

Connect a 4.2kΩ to 33kΩ resistor from RT to SGND to program the switching frequency (f_{sw}) from 500kHz to 4MHz. Calculate the required resistor value R_T to set the switching frequency with the following equation:

$$R_T [\text{k}\Omega] = \frac{f_{\text{sw}} [\text{kHz}] \times 1.067 [\text{V}]}{32 [\mu\text{A}] \times 4 [\text{MHz}]}$$

Higher frequencies allow designs with lower inductor values and less output capacitance. At higher switching frequencies core losses, gate-charge currents, and switching losses increase. When operating from V_{AVIN} < 3V, the f_{sw} frequency should be derated to 3MHz (maximum).

Dual, 4A/2A, 4MHz, Step-Down DC-DC Regulator with Dual LDO Controllers

Effective Input-Voltage Range

Although the MAX15022's regulators can operate from input supplies ranging from 2.5V to 5.5V, the input-voltage range can be effectively limited by the MAX15022's duty-cycle limitations for a given output voltage ($V_{OUT_}$). The maximum input voltage (V_{PVIN_MAX}) can be effectively limited by the controllable minimum on-time ($t_{ON(MIN)}$):

$$V_{PVIN_MAX}[V] \leq \frac{V_{OUT_}[V]}{t_{ON(MIN)}[\mu s] \times f_{SW}[MHz]}$$

where $t_{ON(MIN)}$ is 0.06 μ s (typ).

The minimum input voltage (V_{PVIN_MIN}) can be effectively limited by the maximum controllable duty cycle and is calculated using the following equation:

$$V_{PVIN_MIN}[V] \geq \frac{V_{OUT_}[V]}{1 - (t_{OFF(MIN)}[\mu s] \times f_{SW}[MHz])}$$

where $V_{OUT_}$ is the regulator output voltage and $t_{OFF(MIN)}$ is the 0.06 μ s (typ) controllable off-time.

Inductor Selection

Three key inductor parameters must be specified for operation with the MAX15022: inductance value (L), peak inductor current (I_{PEAK}), and inductor saturation current (I_{SAT}). The minimum required inductance is a function of operating frequency, input-to-output voltage differential, and the peak-to-peak inductor current (ΔI_{P-P}). Higher ΔI_{P-P} allows for a lower inductor value. A lower inductance minimizes size and cost and improves large-signal and transient response. However, efficiency is reduced due to higher peak currents and higher peak-to-peak output-voltage ripple for the same output capacitor. A higher inductance increases efficiency by reducing the ripple current; however, resistive losses due to extra wire turns can exceed the benefit gained from lower ripple current levels especially when the inductance is increased without also allowing for larger inductor dimensions. Choose the inductor's peak-to-peak current, ΔI_{P-P} , in the range of 20% to 50% of the full load current; as a rule of thumb 30% is typical.

Calculate the inductance, L, using the following equation:

$$L[\mu H] = \frac{V_{OUT_}[V] \times (V_{PVIN_}[V] - V_{OUT_}[V])}{V_{PVIN_}[V] \times f_{SW}[MHz] \times \Delta I_{P-P}[A]}$$

where $V_{PVIN_}$ is the input supply voltage, $V_{OUT_}$ is the regulator output voltage, and f_{SW} is the switching frequency. Use typical values for $V_{PVIN_}$ and $V_{OUT_}$ so that efficiency is optimum for typical conditions. The switching frequency (f_{SW}) is programmable between 500kHz and 4MHz (see the *Oscillator* section).

The peak-to-peak inductor current (ΔI_{P-P}), which reflects the peak-to-peak output ripple, is largest at the maximum input voltage. See the *Output-Capacitor Selection* section to verify that the worst-case output current ripple is acceptable.

Select an inductor with a saturation current, I_{SAT} , higher than the maximum peak current to avoid runaway current during continuous output short-circuit conditions. Also, confirm that the inductor's thermal performances and projected temperature rise above ambient does not exceed its thermal capacity. Many inductor manufacturers provide bias/load current versus temperature rise performance curves (or similar) to obtain this information.

Input-Capacitor Selection

The discontinuous input current of the buck converter causes large input ripple currents and therefore the input capacitor must be carefully chosen to withstand the input ripple current and keep the input-voltage ripple within design requirements.

The input-voltage ripple is comprised of ΔV_Q (caused by the capacitor discharge) and ΔV_{ESR} (caused by the ESR of the input capacitor). The total voltage ripple is the sum of ΔV_Q and ΔV_{ESR} which peaks at the end of the on-cycle. Calculate the required input capacitance and ESR for a specified ripple using the following equations:

$$ESR[m\Omega] = \frac{\Delta V_{ESR}[mV]}{\left(I_{LOAD(MAX)} + \frac{\Delta I_{P-P}}{2} \right) [A]}$$

$$C_{PVIN_}[\mu F] = \frac{I_{LOAD(MAX)}[A] \times \left(\frac{V_{OUT_}[V]}{V_{PVIN_}[V]} \right)}{\Delta V_Q[V] \times f_{SW}[MHz]}$$

$$\Delta I_{P-P}[A] = \frac{(V_{PVIN_} - V_{OUT_})[V] \times V_{OUT_}[V]}{V_{PVIN_}[V] \times f_{SW}[MHz] \times L[\mu H]}$$

$I_{LOAD(MAX)}$ is the maximum output current, ΔI_{P-P} is the peak-to-peak inductor current, and $V_{PVIN_}$ is the input supply voltage, $V_{OUT_}$ is the regulator output voltage, and f_{SW} is the switching frequency.

Dual, 4A/2A, 4MHz, Step-Down DC-DC Regulator with Dual LDO Controllers

Use the following equation to calculate the input ripple when only one regulator is enabled:

$$I_{CIN(RMS)}[A] = I_{LOAD(MAX)}[A] \times \frac{\sqrt{V_{OUT_}[V] \times (V_{PVIN_} - V_{OUT_})[V]}}{V_{PVIN_}[V]}$$

The MAX15022 includes UVLO hysteresis to avoid possible unintentional chattering during turn-on. Use additional bulk capacitance if the input source impedance is high. If using a lower input voltage, additional input capacitance helps to avoid possible undershoot below the undervoltage lockout threshold during transient loading.

Output-Capacitor Selection

The allowed output-voltage ripple and the maximum deviation of the output voltage during load steps determine the required output capacitance and its ESR. The output ripple is mainly composed of ΔV_Q (caused by the capacitor discharge) and ΔV_{ESR} (caused by the voltage drop across the equivalent series resistance of the output capacitor). The equations for calculating the output capacitance and its ESR are:

$$C_{OUT}[\mu F] = \frac{\Delta I_{P-P}[A]}{8 \times \Delta V_Q[V] \times f_{SW}[MHz]}$$

$$ESR[m\Omega] = \frac{2 \times \Delta V_{ESR}[mV]}{\Delta I_{P-P}[A]}$$

where ΔI_{P-P} is the peak-to-peak inductor current, and f_{SW} is the switching frequency.

ΔV_{ESR} and ΔV_Q are not directly additive since they are out of phase from each other. If using ceramic capacitors, which generally have low ESR, ΔV_Q dominates. If using electrolytic capacitors, ΔV_{ESR} dominates.

The allowable deviation of the output voltage during fast load transients also affects the output capacitance, its ESR, and its equivalent series inductance (ESL). The output capacitor supplies the load current during a load step until the controller responds with an increased duty cycle. The response time ($t_{RESPONSE}$) depends on the gain bandwidth of the controller (see the *Compensation-Design Guidelines* section). The resistive drop across the output capacitor's ESR (ΔV_{ESR}), the drop across the capacitor's ESL (ΔV_{ESL}), and the capacitor discharge (ΔV_Q) causes a voltage droop during the load-step (I_{STEP}). Use a combination of low-ESR tantalum/aluminum electrolyte and ceramic capacitors for better load transient and voltage ripple performance. Non-leaded capacitors and capacitors in parallel help reduce the ESL. Keep the maximum out-

put-voltage deviation below the tolerable limits of the electronics being powered.

Use the following equations to calculate the required output capacitance, ESR, and ESL for minimal output deviation during a load step:

$$ESR[m\Omega] = \frac{\Delta V_{ESR}[mV]}{I_{STEP}[A]}$$

$$C_{OUT}[\mu F] = \frac{I_{STEP}[A] \times t_{RESPONSE}[\mu s]}{\Delta V_Q[V]}$$

$$ESL[nH] = \frac{\Delta V_{ESL}[mV] \times t_{STEP}[\mu s]}{I_{STEP}[A]}$$

where I_{STEP} is the load step, t_{STEP} is the rise time of the load step, and $t_{RESPONSE}$ is the response time of the controller.

Compensation Design Guidelines

The MAX15022 uses a fixed-frequency, voltage-mode control scheme that regulates the output voltage by comparing the output voltage against a fixed reference. The subsequent "error" voltage that appears at the error-amplifier output (COMP_) is compared against an internal ramp voltage to generate the required duty cycle of the PWM. A second order lowpass LC filter removes the switching harmonics and passes the DC component of the PWM signal to the output. The LC filter has an attenuation slope of -40dB/decade and introduces 180° of phase shift at frequencies above the LC resonant frequency. This phase shift in addition to the inherent 180° of phase shift of the regulator's negative feedback system turns the feedback into unstable positive feedback. The error amplifier and its associated circuitry must be designed to achieve a stable closed-loop system.

The basic controller loop consists of a power modulator (comprised of the regulator's PWM, associated circuitry, and LC filter), an output feedback divider, and an error amplifier. The power modulator has a DC gain set by V_{AVIN}/V_{RAMP} where the ramp voltage (V_{RAMP}) is a function of the V_{AVIN} and results in a fixed DC gain of 4V/V, providing effective feed-forward compensation of input-voltage supply DC variations. The feed-forward compensation eliminates the dependency of the power modulator's gain on the input voltage such that the feedback compensation of the error amplifier requires no modifications for nominal input-voltage changes. The output filter is effectively modeled as a double-pole and a single zero set by the output inductance (L), the DC resistance of the inductor (DCR), the output capacitance (C_{OUT}), and its equivalent series resistance (ESR).

Dual, 4A/2A, 4MHz, Step-Down DC-DC Regulator with Dual LDO Controllers

Below are equations that define the power modulator:

$$\text{Gain}_{\text{MOD(DC)}} = \frac{V_{\text{AVIN}}}{V_{\text{RAMP}}} = \frac{V_{\text{AVIN}}}{\frac{V_{\text{AVIN}}}{4}} = 4V/V$$

$$f_{\text{LC}} = \frac{1}{2\pi \times \sqrt{L \times C_{\text{OUT}} \times \left(\frac{R_{\text{OUT}} + \text{ESR}}{R_{\text{OUT}} + \text{DCR}} \right)}} \approx \frac{1}{2\pi \times \sqrt{L \times C_{\text{OUT}}}}$$

$$f_{\text{ESR}} = \frac{1}{2\pi \times \text{ESR} \times C_{\text{OUT}}}$$

R_{OUT} is the load resistance of the regulator, f_{LC} is the resonant break frequency of the filter, and f_{ESR} is the ESR zero of the output capacitor. See the *Closed-Loop Response and Compensation of Voltage-Mode Regulators* for more information on f_{LC} and f_{ESR} .

The switching frequency (f_{SW}) is programmable between 500kHz and 4MHz. Typically, the crossover frequency (f_{CO})—the frequency at which the system's closed-loop gain is equal to unity (crosses 0dB)—should be set at or below one-tenth the switching frequency ($f_{\text{SW}}/10$) for stable closed-loop response.

The MAX15022 provides an internal voltage-mode error amplifier with its inverting input and its output available to the user for external frequency compensation. The flexibility of external compensation for each controller offers a wide selection of output filtering components, especially the output capacitor. For cost-sensitive applications,

use aluminum electrolytic capacitors while for space-sensitive applications, use low-ESR tantalum or multilayer ceramic chip (MLCC) capacitors at the output. The higher switching frequencies of the MAX15022 allow the use of MLCC as the primary filter capacitor(s).

First, select the passive and active power components that meet the application output ripple, component size, and component cost requirements. Second, choose the small-signal compensation components to achieve the desired closed-loop frequency response and phase margin as outlined below.

Closed-Loop Response and Compensation of Voltage-Mode Regulators

The power modulator's LC lowpass filter exhibits a variety of responses, dependent on the value of the L and C and their parasitics. Higher resistive parasitics reduce the Q of the circuit, reducing the peak gain and phase of the system; however, efficiency is also reduced under these circumstances.

One such response is shown in Figure 4a. In this example, the ESR zero occurs relatively close to the filter's resonant break frequency, f_{LC} . As a result, the power modulator's uncompensated crossover is approximately one third the desired crossover frequency, f_{CO} . Note also, the uncompensated rolloff through the 0dB plane follows a single-pole, -20dB/decade slope and 90° of phase lag. In this instance, the inherent phase margin ensures a stable system; however, the gain-bandwidth product is not optimized.

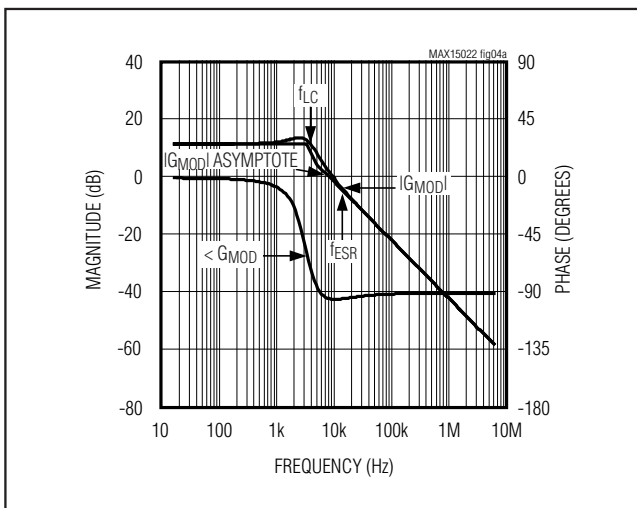

Figure 4a. Power Modulator Gain and Phase Response with Lossy Bulk Output Capacitor(s) (Aluminum)

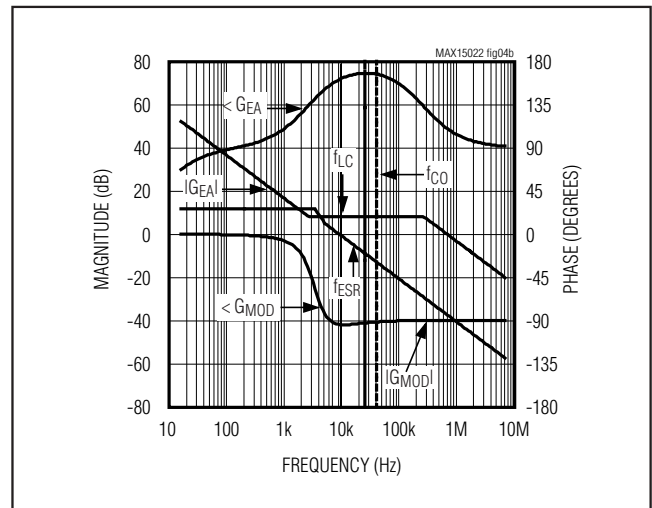

Figure 4b. Power Modulator and Type II Compensator Gain and Phase Response with Lossy Bulk Output Capacitor(s) (Aluminum)

Dual, 4A/2A, 4MHz, Step-Down DC-DC Regulator with Dual LDO Controllers

As seen in Figure 4b, a Type II compensator provides for stable closed-loop operation, leveraging the +20dB/decade slope of the capacitor's ESR zero, while extending the closed-loop gain bandwidth of the regulator. The zero crossover now occurs at approximately three times the uncompensated crossover frequency, f_{CO} .

The Type II compensator's midfrequency gain (approximately 12dB shown here) is designed to compensate for the power modulator's attenuation at the desired crossover frequency, f_{CO} ($Gain_{E/A} + Gain_{MOD} = 0dB$ at f_{CO}). In this example, the power modulator's inherent -20dB/decade rolloff above the ESR zero ($f_{ZERO, ESR}$) is leveraged to extend the active regulation gain bandwidth of the voltage regulator. As shown in Figure 4b, the net result is a three times increase in the regulator's gain bandwidth while providing greater than 75° of phase margin (the difference between $Gain_{E/A}$ and $Gain_{MOD}$ respective phases at crossover, f_{CO}).

Other filter schemes pose their own problems. For instance, when choosing high-quality filter capacitor(s), e.g. MLCCs, the inherent ESR zero may occur at a much higher frequency, as shown in Figure 4c.

As with the previous example, the actual gain and phase response is overlaid on the power modulator's asymptotic gain response. One readily observes the more dramatic gain and phase transition at or near the power modulator's resonant frequency, f_{LC} , versus the

gentler response of the previous example. This is due to the filter components' lower parasitic (DCR and ESR) and corresponding higher frequency of the inherent ESR zero. In this example, the desired crossover frequency occurs below the ESR zero frequency.

In this example, a compensator with an inherent midfrequency double-zero response is required to mitigate the effects of the filter's double-pole phase lag. This is available with the Type III topology.

As demonstrated in Figure 4d, the Type III's midfrequency double-zero gain (exhibiting a +20dB/decade slope, noting the compensator's pole at the origin) is designed to compensate for the power modulator's double-pole -40dB/decade attenuation at the desired crossover frequency, f_{CO} (again, $Gain_{E/A} + Gain_{MOD} = 0dB$ at f_{CO}) (see Figure 4d).

In the above example, the power modulator's inherent (midfrequency) -40dB/decade rolloff is mitigated by the midfrequency double zero's +20dB/decade gain to extend the active regulation gain bandwidth of the voltage regulator. As shown in Figure 4d, the net result is an approximate doubling in the controller's gain bandwidth while providing greater than 55° of phase margin (the difference between $Gain_{E/A}$ and $Gain_{MOD}$ respective phases at crossover, f_{CO}).

Design procedures for both Type II and Type III compensators are shown below.

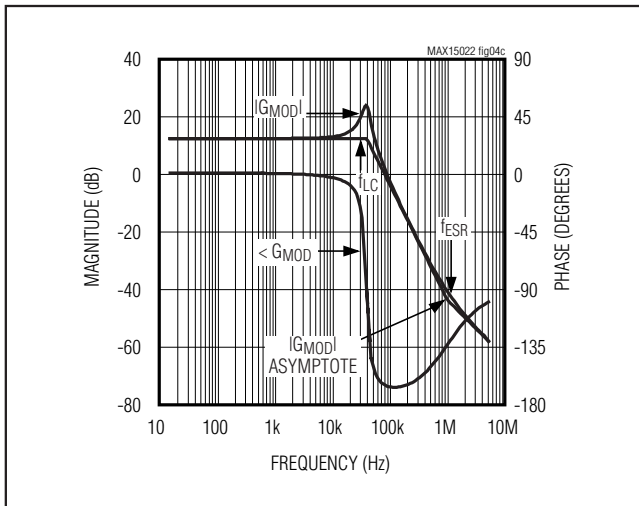

Figure 4c. Power Modulator Gain and Phase Response with Low-Parasitic Capacitor(s) (MLCCs)

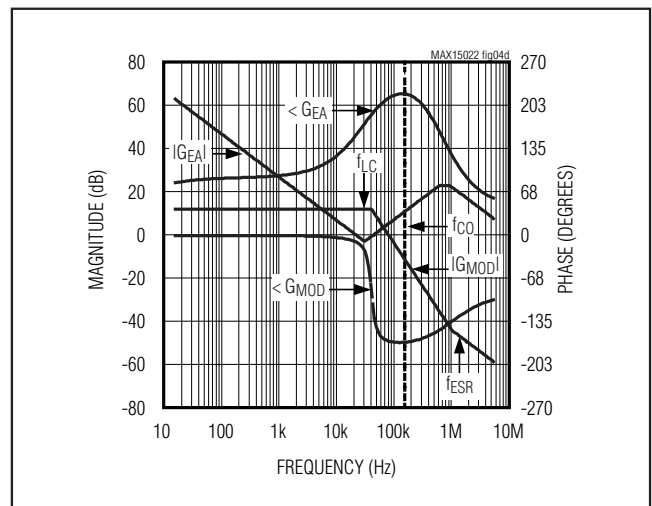

Figure 4d. Power Modulator and Type III Compensator Gain and Phase Response with Low Parasitic Capacitors (MLCCs)

Dual, 4A/2A, 4MHz, Step-Down DC-DC Regulator with Dual LDO Controllers

Type II: Compensation when $f_{CO} > f_{ZERO}$, ESR

When the f_{CO} is greater than f_{ESR} , a Type II compensation network provides the necessary closed-loop compensated response. The Type II compensation network provides a midband compensating zero and a high-frequency pole (see Figures 5a and 5b).

$R_F C_F$ provides the midband zero $f_{MID,ZERO}$, and $R_F C_{CF}$ provides the high-frequency pole, $f_{HIGH,POLE}$. Use the following procedure to calculate the compensation network components.

Calculate the f_{ESR} and LC double pole, f_{LC} :

$$f_{ESR} = \frac{1}{2\pi \times ESR \times C_{OUT}}$$

$$f_{LC} \approx \frac{1}{2\pi \times \sqrt{L \times C_{OUT}}}$$

where C_{OUT} is the regulator output capacitor and ESR is the series resistance of C_{OUT} . See the *Output-Capacitor Selection* section for more information on calculating C_{OUT} and ESR.

Set the compensator's leading zero, f_{Z1} , at or below the filter's resonant double-pole frequency from:

$$f_{Z1} \leq f_{LC}$$

Set the compensator's high-frequency pole, f_{P1} , at or below one-half the switching frequency, f_{SW} :

$$f_{P1} \leq \frac{f_{SW}}{2}$$

To maximize the compensator's phase lead, set the desired crossover frequency, f_{CO} , equal to the geometric mean of the compensator's leading zero, f_{Z1} , and high-frequency pole, f_{P1} , as follows:

$$f_{CO} = \sqrt{f_{Z1} \times f_{P1}}$$

Select the feedback resistor, R_F , in the range of 3.3k Ω to 30k Ω .

Calculate the gain of the modulator ($Gain_{MOD}$)—comprised of the regulator's PWM, LC filter, feedback divider, and associated circuitry—at the desired crossover frequency, f_{CO} , using the following equation:

$$Gain_{MOD} = 4(V_M) \times \frac{ESR [m\Omega]}{(2\pi \times f_{CO} [kHz] \times L [\mu H])} \times \frac{V_{FB} [V]}{V_{OUT_} [V]}$$

where V_{FB} is the 0.6V (typ) FB_- input-voltage set-point, L is the value of the regulator inductor, ESR is the

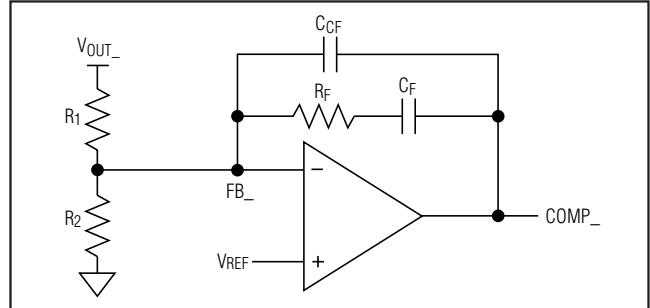

Figure 5a. Type II Compensation Network

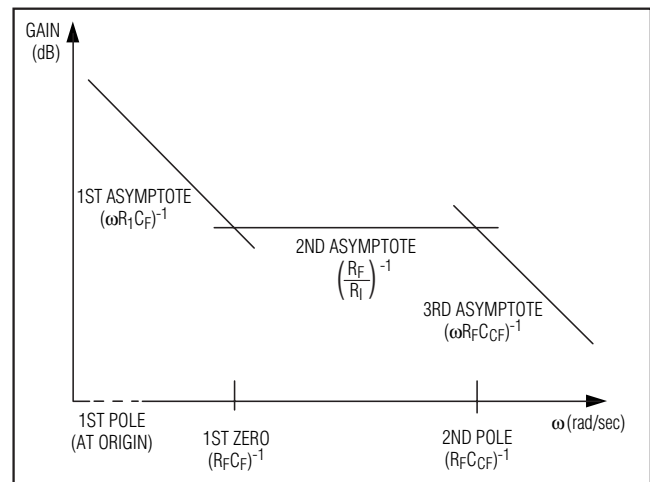

Figure 5b. Type II Compensation Network Response

series resistance of the output capacitor, and $V_{OUT_}$ is the desired output voltage.

The gain of the error amplifier ($Gain_{E/A}$) in the midband frequencies is:

$$Gain_{E/A} = \frac{R_F [k\Omega]}{R_1 [k\Omega]}$$

The total loop gain is the product of the modulator gain and the error amplifier gain at f_{CO} and should be set equal to 1 as follows:

$$Gain_{MOD} \times Gain_{E/A} = 1$$

So:

$$20 \times \log_{10} \left[\frac{R_F}{R_1} \right] + 20 \times \log_{10} \left[\frac{4 \times ESR \times V_{FB}}{2\pi \times f_{CO} \times L \times V_{OUT_}} \right] = 0 \text{ dB}$$

$$\frac{R_F}{R_1} \times \frac{4 \times ESR \times V_{FB}}{2\pi \times f_{CO} \times L \times V_{OUT_}} = 1$$

Dual, 4A/2A, 4MHz, Step-Down DC-DC Regulator with Dual LDO Controllers

Solving for R₁:

$$R_1 \text{ [k}\Omega\text{]} = \frac{R_F \text{ [k}\Omega\text{]} \times 4 \times \text{ESR [m}\Omega\text{]} \times V_{FB} \text{ [V]}}{2\pi \times f_{CO} \text{ [kHz]} \times L \text{ [}\mu\text{H]} \times V_{OUT_} \text{ [V]}}$$

where V_{FB} is the 0.6V (typ) FB₋ input-voltage set-point, L is the value of the regulator inductor, ESR is the series resistance of the output capacitor, and V_{OUT_-} is the desired output voltage.

- 1) C_F is determined from the compensator's leading zero, f_{Z1}, and R_F as follows:

$$C_F \text{ [}\mu\text{F]} = \frac{1}{2\pi \times R_F \text{ [k}\Omega\text{]} \times f_{Z1} \text{ [kHz]}}$$

- 2) C_{CF} is determined from the compensator's high-frequency pole, f_{P1}, and R_F as follows:

$$C_{CF} \text{ [}\mu\text{F]} = \frac{1}{2\pi \times R_F \text{ [k}\Omega\text{]} \times f_{P1} \text{ [kHz]}}$$

- 3) Calculate R₂ using the following equation:

$$R_2 \text{ [k}\Omega\text{]} = R_1 \text{ [k}\Omega\text{]} \times \frac{V_{FB} \text{ [V]}}{V_{OUT_} \text{ [V]} - V_{FB} \text{ [V]}}$$

where V_{FB} = 0.6V (typ) and V_{OUT_-} is the output voltage of the regulator.

Type III: Compensation when f_{CO} < f_{ESR}

As indicated above, the position of the output capacitor's inherent ESR zero is critical in designing an appropriate compensation network. When low-ESR ceramic output capacitors (MLCCs) are used, the ESR zero frequency (f_{ESR}) is usually much higher than the desired crossover frequency (f_{CO}). In this case, a Type III compensation network is recommended (see Figure 6a).

As shown in Figure 6b, the Type III compensation network introduces two zeros and three poles into the control loop. The error amplifier has a low-frequency pole at the origin, two zeros, and two higher frequency poles at the following frequencies:

$$f_{Z1} = \frac{1}{2\pi \times R_F \times C_F}$$

$$f_{Z2} = \frac{1}{2\pi \times C_1 \times (R_1 + R_1)}$$

Two midband zeros (f_{Z1} and f_{Z2}) are designed to compensate for the pair of complex poles introduced by the LC filter.

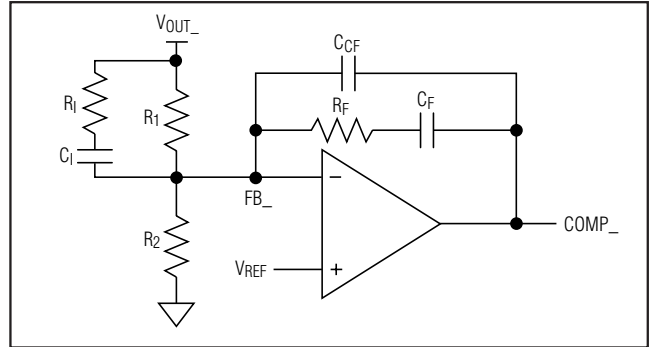

Figure 6a. Type III Compensation Network

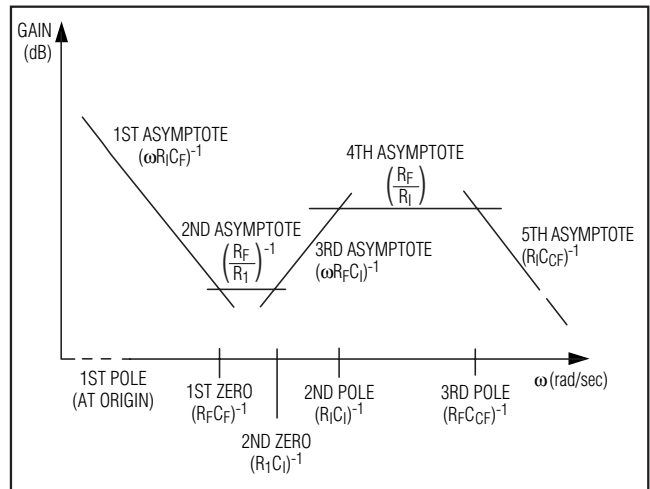

Figure 6b. Type III Compensation Network Response

f_{P1} introduces a pole at zero frequency (integrator) for nulling DC output-voltage errors.

$$f_{P1} = \text{at the origin (0Hz)}$$

Depending on the location of the ESR zero (f_{ESR}), f_{P2} can be used to cancel it, or to provide additional attenuation of the high-frequency output ripple.

$$f_{P2} = \frac{1}{2\pi \times R_1 \times C_1}$$

f_{P3} attenuates the high-frequency output ripple.

$$f_{P3} = \frac{1}{2\pi \times R_F \times (C_F \parallel C_{CF})} = \frac{1}{2\pi \times R_F \times \frac{C_F \times C_{CF}}{C_F + C_{CF}}}$$

Since C_{CF} << C_F then:

$$f_{P3} = \frac{1}{2\pi \times R_F \times C_{CF}}$$

Dual, 4A/2A, 4MHz, Step-Down DC-DC Regulator with Dual LDO Controllers

The locations of the zeros and poles should be such that the phase margin peaks around f_{CO} .

Set the ratios of f_{CO} -to- f_z and f_p -to- f_{CO} equal to one another, e.g., $\frac{f_{CO}}{f_z} = \frac{f_p}{f_{CO}} = 5$ is a good number to get approximately

60° of phase margin at f_{CO} . Whichever technique, it is important to place the two zeros at or below the double pole to avoid the conditional stability issue.

The following procedure is recommended:

- 1) Select a crossover frequency, f_{CO} , at or below one-tenth the switching frequency (f_{SW}):

$$f_{CO}[\text{kHz}] \leq \frac{f_{SW}[\text{kHz}]}{10}$$

- 2) Calculate the LC double-pole frequency, f_{LC} :

$$f_{LC}[\text{MHz}] \approx \frac{1}{2\pi \times \sqrt{L[\mu\text{H}] \times C_{OUT}[\mu\text{F}]}}$$

where C_{OUT} is the output capacitor of the regulator.

- 3) Select the feedback resistor, R_F , in the range of 3.3kΩ to 30kΩ.

- 4) Place the compensator's first zero $f_{Z1} = \frac{1}{2\pi \times R_F \times C_F}$ at or below the output filter's double-pole, f_{LC} , as follows:

$$C_F[\mu\text{F}] = \frac{1}{2\pi \times R_F[\text{k}\Omega] \times 0.5 \times f_{LC}[\text{kHz}]}$$

- 5) The gain of the modulator (Gain_{MOD})—comprised of the regulator's PWM, LC filter, feedback divider, and associated circuitry—at the crossover frequency is:

$$\text{Gain}_{MOD} = 4 \times \frac{1}{(2\pi \times f_{CO}[\text{MHz}])^2 \times L[\mu\text{H}] \times C_{OUT}[\mu\text{F}]}$$

The gain of the error amplifier ($\text{Gain}_{E/A}$) in midband frequencies is:

$$\text{Gain}_{E/A} = 2\pi \times f_{CO}[\text{kHz}] \times C_I[\mu\text{F}] \times R_F[\text{k}\Omega]$$

The total loop gain is the product of the modulator gain and the error amplifier gain at f_{CO} should be equal to 1, as follows:

$$\text{Gain}_{MOD} \times \text{Gain}_{E/A} = 1$$

So:

$$4 \times \frac{1}{(2\pi \times f_{CO}[\text{kHz}])^2 \times C_{OUT}[\mu\text{F}] \times L[\mu\text{H}]} \times 2\pi \times f_{CO}[\text{kHz}] \times C_I[\mu\text{F}] \times R_F[\text{k}\Omega] = 1$$

Solving for C_I :

$$C_I[\text{pF}] = \frac{(2\pi \times f_{CO}[\text{kHz}] \times L[\mu\text{H}] \times C_{OUT}[\mu\text{F}])}{4 \times R_F[\text{k}\Omega]}$$

- 6) For those situations where $f_{LC} < f_{CO} < f_{ESR} < f_{SW}/2$, as with low-ESR tantalum capacitors, the compensator's second pole (f_{P2}) should be used to cancel f_{ESR} . This provides additional phase margin. On the system Bode plot, the loop gain maintains its +20dB/decade slope up to 1/2 of the switching frequency versus flattening out soon after the 0dB crossover. Then set:

$$f_{P2} = f_{ESR}$$

If a ceramic capacitor is used, then the capacitor ESR zero, f_{ESR} , is likely to be located even above 1/2 of the switching frequency, that is $f_{LC} < f_{CO} < f_{SW}/2 < f_{ESR}$. In this case, the frequency of the second pole (f_{P2}) should be placed high enough not to significantly erode the phase margin at the crossover frequency. For example, f_{P2} can be set at 5 x f_{CO} , so that its contribution to phase loss at the crossover frequency f_{CO} is only about 11°:

$$f_{P2} = 5 \times f_{CO}$$

Once f_{P2} is known, calculate R_1 :

$$R_1[\text{k}\Omega] = \frac{1}{2\pi \times f_{P2}[\text{kHz}] \times C_I[\mu\text{F}]}$$

- 7) Place the second zero (f_{Z2}) at 0.2 x f_{CO} or at f_{LC} , whichever is lower, and calculate R_1 using the following equation:

$$R_1[\text{k}\Omega] = \frac{1}{2\pi \times f_{Z2}[\text{kHz}] \times C_I[\mu\text{F}]}$$

- 8) Place the third pole (f_{P3}) at 1/2 the switching frequency and calculate C_{CF} from:

$$C_{CF}[\text{nF}] = \frac{1}{(2\pi \times 0.5 \times f_{SW}[\text{MHz}] \times R_F[\text{k}\Omega])}$$

- 9) Calculate R_2 as:

$$R_2[\text{k}\Omega] = R_1[\text{k}\Omega] \times \frac{V_{FB}[\text{V}]}{V_{OUT}[\text{V}] - V_{FB}[\text{V}]}$$

where $V_{FB} = 0.6\text{V}$ (typ).

Dual, 4A/2A, 4MHz, Step-Down DC-DC Regulator with Dual LDO Controllers

LDO Controllers Design Procedure

PNP Pass Transistors Selection

The pass transistors must meet specifications for current gain (β), input capacitance, collector-emitter saturation voltage, and power dissipation. The transistor's current gain limits the guaranteed maximum output current to:

$$I_{OUT3/4}[A] = \left(I_{B3/4(MIN)}[A] - \frac{V_{BE}[V]}{R_{PULL}[\Omega]} \right) \times \beta$$

where $I_{B3/4(MIN)}$ is the minimum base-drive current and R_{PULL} is the pullup resistor connected between the transistor's base and emitter.

In addition, to avoid premature dropout, V_{CE-SAT} must be less than or equal to $(V_{PVIN(MIN)} - V_{OUT3/4})$. Furthermore, the transistor's current gain increases the linear regulator's DC loop gain (see the *Stability Requirements* section), so excessive gain destabilizes the output. Therefore, transistors with high current gain at the maximum output current, such as Darlington transistors, are not recommended. The transistor's input capacitance and input resistance also create a second pole, which could be low enough to destabilize the LDO when the output is heavily loaded.

The transistor's saturation voltage at the maximum output current determines the minimum input-to-output voltage differential that the linear regulator supports. Alternately, the package's power dissipation could limit the useable maximum input-to-output voltage differential.

The maximum power-dissipation capability of the transistor's package and mounting must support the actual power dissipation in the device without exceeding the maximum junction temperature. The power dissipated equals the maximum load current multiplied by the maximum input-to-output voltage differential.

Output 3 and Output 4 Voltage Selection

The MAX15022 positive linear-regulator output voltage is set with a resistive divider from the desired output ($V_{OUT3/4}$) to FB3/4 to SGND (see Figures 7 and 8). First, select the $R_{2FB3/4}$ resistance value (below 30k Ω). Then, solve for $R_{1FB3/4}$:

$$R_{1FB3/4}[k\Omega] = R_{2FB3/4}[k\Omega] \left(\frac{V_{OUT3/4}[V]}{V_{FB3/4}[V]} - 1 \right)$$

where $V_{OUT3/4}$ can support output voltages as low as 0.6V and $V_{FB3/4}$ is 0.6V (typ).

Stability Requirements

The MAX15022's B3 and B4 outputs are designed to drive bipolar PNP transistors. These PNP transistors form linear regulators with positive outputs. An internal transconductance amplifier drives the external pass transistors. The transconductance amplifier, pass transistor's specifications, the base-emitter resistor, and the output capacitor determine the loop stability.

The total DC loop gain (A_V) is the product of the gains of the internal transconductance amplifier, the gain from base to collector of the pass transistor, and the attenuation of the feedback divider. The transconductance amplifier regulates the output voltage by controlling the pass transistor's base current. Its DC gain is approximately:

$$g_{C-} \times \left(\frac{R_{IN} \times R_{P1/2}}{R_{IN} + R_{P1/2}} \right)$$

where g_{C-} is the transconductance of the internal amplifier and is typically 1.2mA/mV, $R_{P1/2}$ is the resistor across the base and the emitter of the pass transistor in k Ω , and R_{IN} is the input resistance of the pass transistor, and can be calculated by:

$$R_{IN}[k\Omega] = \beta \times \left(\frac{26[mV]}{I_{OUT3/4}[\mu A]} \right)$$

The DC gain for the pass transistor (A_P), including the feedback divider, is approximately:

$$A_P = g_{m-PNP} \times \left[\frac{R_{OUT3/4} \times (R_{1FB3/4} + R_{2FB3/4})}{R_{OUT3/4} + R_{1FB3/4} + R_{2FB3/4}} \right] \times \frac{R_{2FB3/4}}{R_{1FB3/4} + R_{2FB3/4}}$$

$$\text{where } g_{m-PNP} = \frac{I_{OUT3/4} [mA]}{26 [mV]}$$

The total DC loop gain for output 3 and output 4 is:

$$A_V = g_{C-} \times \left(\frac{R_{IN} \times R_{P1/2}}{R_{IN} + R_{P1/2}} \right) \times A_P$$

The output capacitance (C_{OUT-}) and the load resistance (R_{OUT-}) create a dominant pole (f_{POLE1}) at:

$$f_{POLE1}[kHz] = \frac{1}{2\pi \times C_{OUT3/4}[\mu F] \times R_{OUT3/4}[k\Omega]} = \frac{I_{OUT3/4(MAX)}[mA]}{2\pi \times C_{OUT3/4}[\mu F] \times V_{OUT3/4}[V]}$$

Dual, 4A/2A, 4MHz, Step-Down DC-DC Regulator with Dual LDO Controllers

The input capacitance to the base of the pass transistor (C_{QIN}), any external base-to-emitter capacitance (C_{BE} , see the *Base-Drive Noise Reduction* section), the transistor's input resistance (R_{IN}), and the base-to-emitter pullup resistor ($R_{P_}$) set a second pole:

$$f_{POLE2}[\text{kHz}] = \frac{1}{2\pi(C_{BE} + C_{QIN})[\mu\text{F}] \times R_{TOTAL}[\text{k}\Omega]}$$

where $R_{TOTAL} = R_{IN} \parallel R_{P1/2}$.

To maintain the stability, at a minimum the following condition must be satisfied:

$$A_V \times f_{POLE1} < f_{POLE2}$$

i.e., the second pole must occur above the unity-gain crossover. At heavy output load, we can simplify as follows:

$$R_{OUT3/4} \ll R_{1FB3/4} + R_{2FB3/4}$$

$$C_{BE} \ll C_{QIN} \approx g_{m-PNP} \times \tau_F$$

$$R_{P1/2} \gg R_{IN} \approx \frac{\beta}{g_{m-PNP}}$$

And hence, the output capacitance ($C_{OUT3/4}$) must satisfy the following equation:

$$C_{OUT3/4} > \alpha \times g_{C_} \times \tau_F \times \beta^2$$

where:

$$\alpha = \frac{R_{2FB3/4}}{R_{1FB3/4} + R_{2FB3/4}}$$

β is the current gain of the PNP transistor, $g_{C_}$ is the transconductance of the internal amplifier (1.2mA/mV typical), and τ_F is the forward transit time of the PNP transistor. For example, using a PNP transistor with a β of 120, τ_F of 400ps, $g_{C_} = 1.2\text{mA/mV}$, and $\alpha = 0.5$ for a 1.2V output voltage, C_{OUT} must be at least 3.9 μF .

If the second pole occurs well after unity-gain crossover, the linear regulator remains stable. If not, then increase the output capacitance, $C_{OUT3/4}$, such that:

$$f_{POLE2} > 2 \times f_{COUT_}$$

If the output capacitor is a high-ESR capacitor, then cancel the ESR zero with a pole at $FB3/4$. This is accomplished by adding a capacitor ($C_{FB3/4}$) from $FB3/4$ to ground, such that:

$$C_{FB3/4}[\mu\text{F}] = \frac{1}{2\pi \times (R_{1FB3/4} \parallel R_{2FB3/4})[\text{k}\Omega] \times f_{ESR}[\text{kHz}]}$$

For a sufficiently low output capacitance, choose a fast PNP transistor without an excessively high β . Note, selecting a transistor with a β that is too low can adversely impact load regulation.

Output 3 and Output 4 Capacitors

Connect C_{OUT} (as determined above) between the linear regulator's output and ground, as close as possible to the MAX15022 and the external pass transistors. Depending on the selected pass transistor, larger capacitor values may be required for stability (see the *Stability Requirement* section).

Once the minimum capacitor value for stability is determined, verify that the linear regulator's output does not contain excessive noise. Although adequate for stability, small capacitor values can provide too much bandwidth, making the linear regulator sensitive to noise. Larger capacitor values reduce the bandwidth, thereby reducing the regulator's noise sensitivity.

Base-Drive Noise Reduction

The high-impedance base driver is susceptible to system noise, especially when the linear regulator is lightly loaded. Capacitively coupled switching noise or inductively coupled EMI on the base drive may cause fluctuations in the base current, which appear as noise on the linear regulator's output. To avoid this, keep the base-driver traces away from the step-down converter and as short as possible to minimize noise coupling.

A bypass capacitor (C_{BE}) can be placed across the base-to-emitter resistor. This bypass capacitor, in addition to the transistor's input capacitance, reduces the frequency of the second pole (f_{POLE2}) that could destabilize the linear regulator. Therefore, the stability requirements determine the maximum base-to-emitter capacitance (C_{BE}) that can be added. A capacitance in the range of 470pF to 2200pF is recommended.

Dual, 4A/2A, 4MHz, Step-Down DC-DC Regulator with Dual LDO Controllers

Minimum Load Requirements (Linear Regulators)

Under no-load conditions, leakage currents from the pass transistors supply the output capacitor, even when the transistor is off. Generally, this is not a problem since the feedback resistors' current drains the excess charge. However, charge can build up on the output capacitor over temperature, making output voltage rise above its set point. Care must be taken to ensure the feedback resistors' current exceeds the pass transistor's leakage current over the entire temperature range.

Thermal Consideration

The power dissipated by the pass transistor is calculated by:

$$P_{P3/4} = (V_{IN} - V_{OUT3/4}) \times I_{OUT3/4}$$

where V_{IN} is the input to the transistor of the LDO.

Heatsink the transistor adequately to prevent a thermal runaway condition. Refer to the transistor data sheet for thermal calculations.

Applications Information

PCB Layout Guidelines

Careful PCB layout is critical to achieve clean and stable operation. Follow these guidelines for good PCB layout:

- 1) Place decoupling capacitors as close as possible to the IC pins.
- 2) Keep SGND and PGND isolated. Connect them at one single point typically close to the negative terminal of the input filter capacitor. Use as short a trace as possible.
- 3) Route high-speed switching nodes (LX_) away from sensitive analog areas (FB_, COMP_, B_, and EN_).
- 4) Distribute the power components evenly across the board for proper heat dissipation.
- 5) Ensure all feedback connections are short and direct. Place feedback resistors as close as possible to the IC.
- 6) Place the output capacitors close to the load.
- 7) Connect the MAX15022 exposed pad to a large copper plane to maximize its power dissipation capability. Thermal resistances can be obtained using the method described in JEDEC specification JESD51-7. Connect the exposed pad to SGND plane. Do not connect the exposed pad to the SGND pin directly underneath the IC.
- 8) Use 2oz. copper to keep trace inductance and resistance to a minimum. Thin copper PCBs can compromise efficiency since high currents are involved in the application. Also thicker copper conducts heat more effectively, thereby reducing thermal impedance.
- 9) A reference PCB layout included in the MAX15022 Evaluation Kit is also provided to further aid layout.

Dual, 4A/2A, 4MHz, Step-Down DC-DC Regulator with Dual LDO Controllers

Typical Operating Circuits

MAX15022

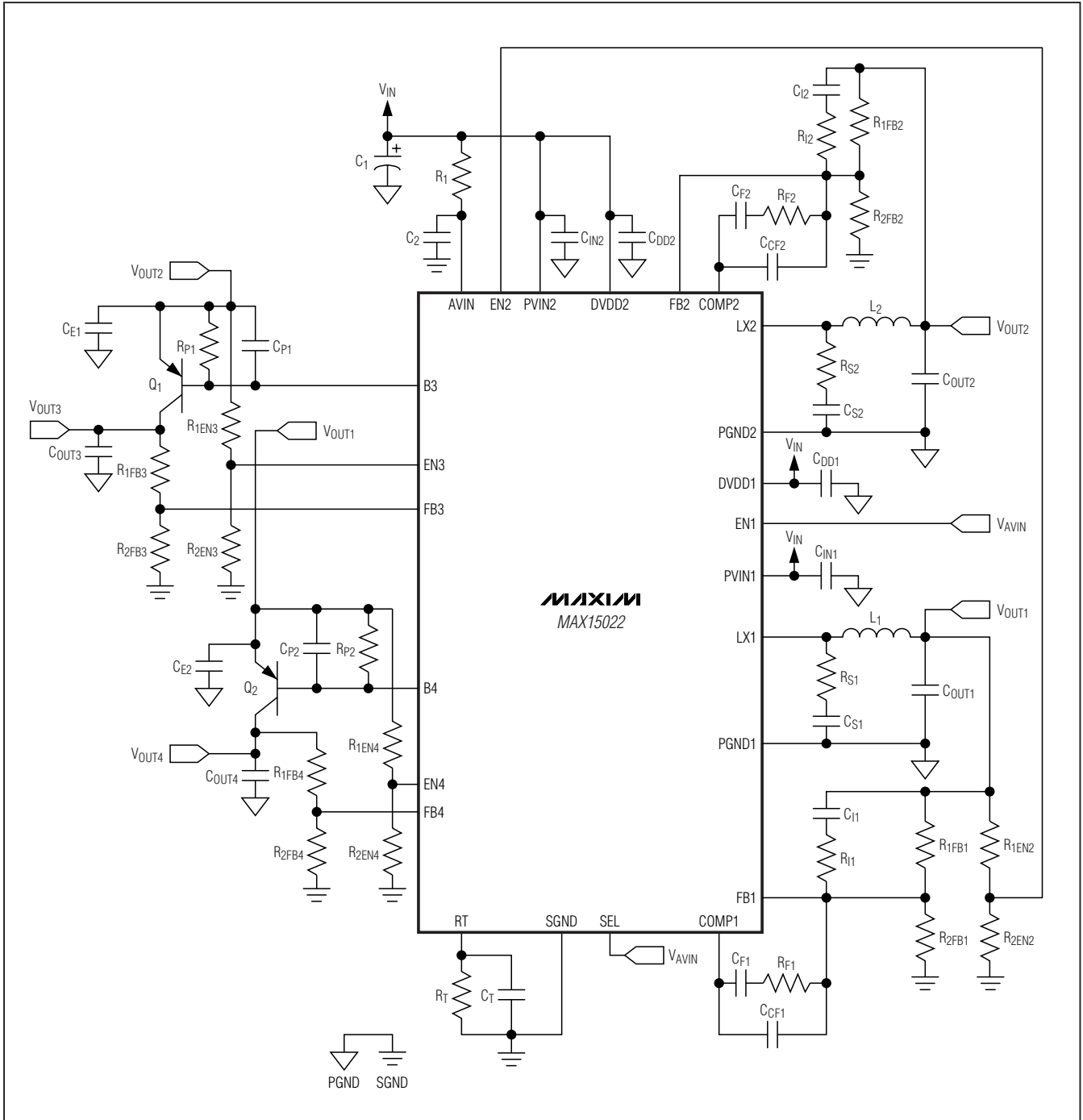

Figure 7. MAX15022 Double Buck with Tracking and Two Additional LDOs

Dual, 4A/2A, 4MHz, Step-Down DC-DC Regulator with Dual LDO Controllers

Typical Operating Circuits (continued)

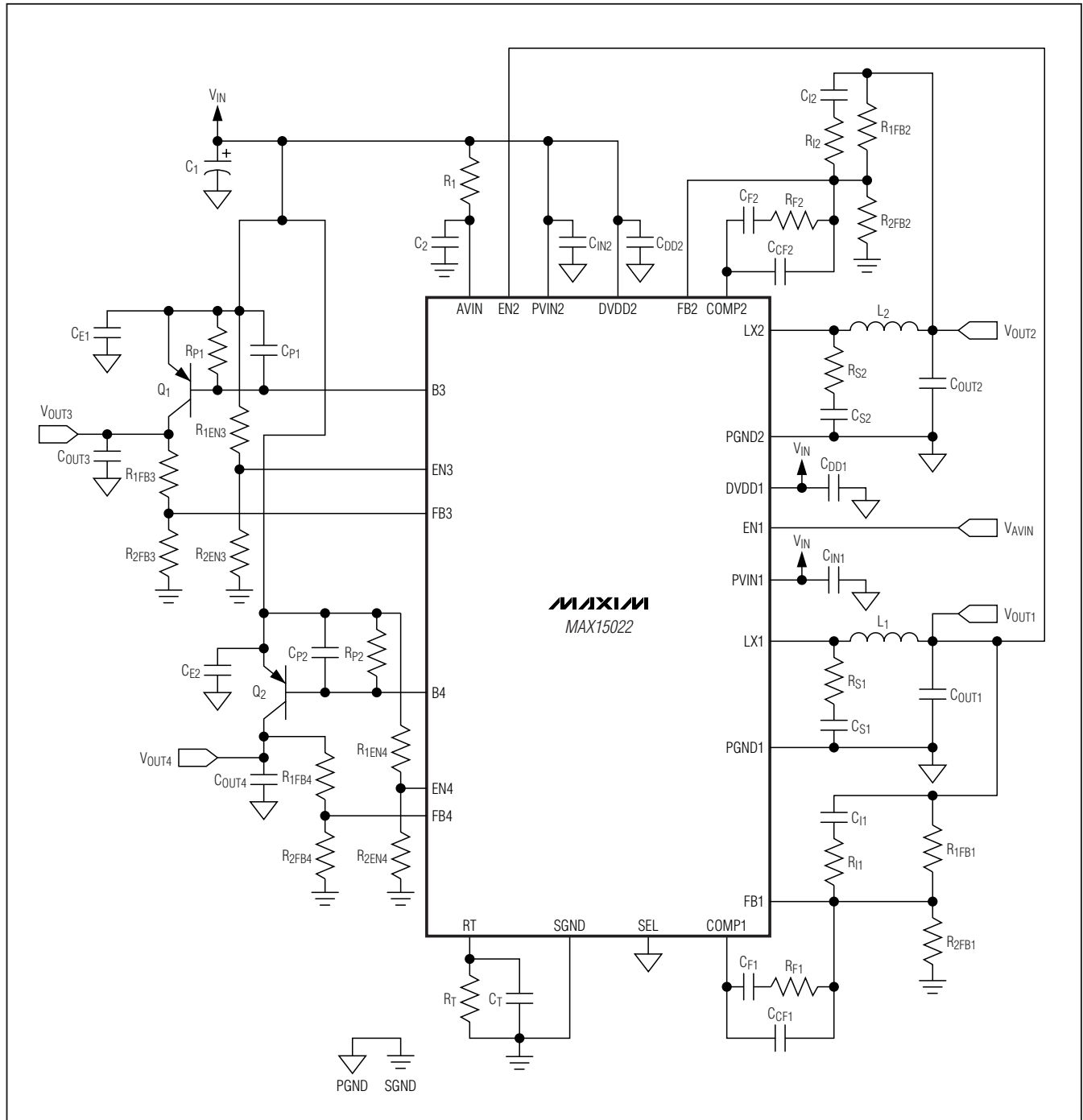

Figure 8. MAX15022 Double Buck with Sequencing and Two Additional LDOs

Dual, 4A/2A, 4MHz, Step-Down DC-DC Regulator with Dual LDO Controllers

Chip Information

PROCESS: BiCMOS

Package Information

For the latest package outline information, go to www.maxim-ic.com/packages.

PACKAGE TYPE	PACKAGE CODE	DOCUMENT NO.
28 TQFN	T2855-6	21-0140

MAX15022

Maxim cannot assume responsibility for use of any circuitry other than circuitry entirely embodied in a Maxim product. No circuit patent licenses are implied. Maxim reserves the right to change the circuitry and specifications without notice at any time.

Maxim Integrated Products, 120 San Gabriel Drive, Sunnyvale, CA 94086 408-737-7600 _____ 27