

EVALUATION KIT
AVAILABLE

MAXIM

Small, High-Efficiency, Five-Channel Digital Still Camera Power Supply

General Description

The MAX1565 provides a complete power-supply solution for digital still and video cameras through the integration of ultra-high-efficiency step-up/step-down DC-to-DC converters along with three auxiliary step-up controllers. The MAX1565 is targeted for applications that use either 2 or 3 alkaline or NiMH batteries as well as those using a single lithium-ion (Li+) battery.

The step-up DC-to-DC converter accepts inputs from 0.7V to 5.5V and regulates a resistor-adjustable output from 2.7V to 5.5V. It uses internal MOSFETs to achieve 95% efficiency. Adjustable operating frequency facilitates design for optimum size, cost, and efficiency.

The step-down DC-to-DC converter can produce output voltages as low as 1.25V and also utilizes internal MOSFETs to achieve 95% efficiency. An internal soft-start ramp minimizes surge current from the battery. The converter can operate from the step-up output providing buck-boost capability with up to 90% compound efficiency, or it can run directly from the battery if buck-boost operation is not needed.

The MAX1565 features auxiliary step-up controllers that power CCD, LCD, motor actuator, and backlight circuits. The device also features low-cost expandability by supplying power, an oscillator signal, and a reference to the MAX1801 SOT23 slave controller that supports step-up, SEPIC, and flyback configurations.

The MAX1565 is available in a space-saving 32-pin thin QFN package.

Applications

Digital Still Cameras
Digital Video Cameras
PDAs

Typical Operating Circuit

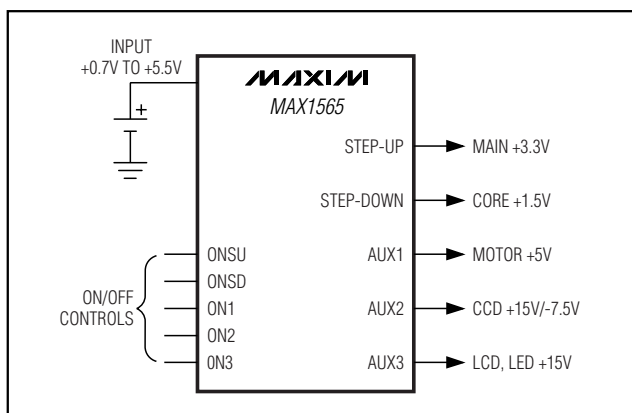

Features

- ◆ Step-Up DC-to-DC Converter
 - 95% Efficient
 - 3.3V (Fixed) or 2.7V to 5.5V (Adjustable) Output Voltage
- ◆ Step-Down DC-to-DC Converter
 - Operate from Battery for 95% Efficient Buck
 - Combine with Step-Up for 90% Efficient Buck-Boost
 - Adjustable Output Down to 1.25V
- ◆ Three Auxiliary PWM Controllers
- ◆ Up to 1MHz Operating Frequency
- ◆ 1µA Shutdown Mode
- ◆ Internal Soft-Start Control
- ◆ Overload Protection
- ◆ Compact 32-Pin, 5mm x 5mm Thin QFN Package

Ordering Information

PART	TEMP RANGE	PIN-PACKAGE
MAX1565ETJ	-40°C to +85°C	32 Thin QFN

Pin Configuration

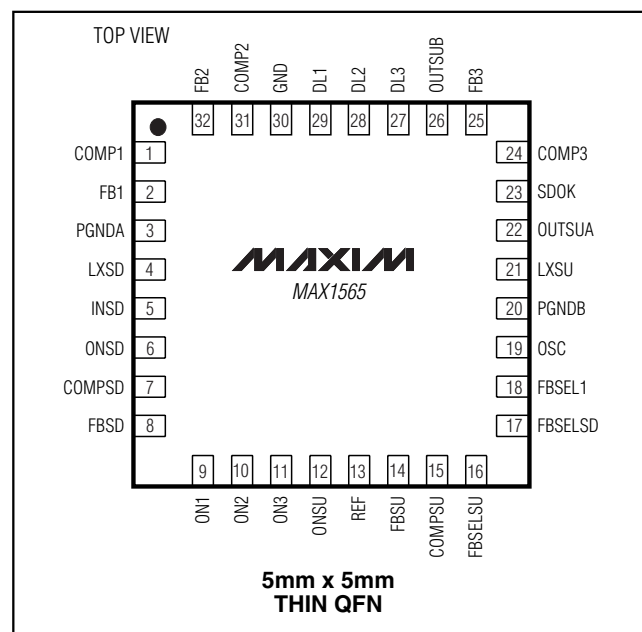

MAXIM

Maxim Integrated Products 1

For pricing, delivery, and ordering information, please contact Maxim/Dallas Direct! at 1-888-629-4642, or visit Maxim's website at www.maxim-ic.com.

MAX1565

Small, High-Efficiency, Five-Channel Digital Still Camera Power Supply

ABSOLUTE MAXIMUM RATINGS

OUTSU_, INSD, SDOK, ON_, FB_, FBSEL_ to GND	-0.3V to +6V	Continuous Power Dissipation ($T_A = +70^\circ\text{C}$) 32-Pin Thin QFN (derate 22mW/ $^\circ\text{C}$ above $+70^\circ\text{C}$)	1700mW
PGND to GND	-0.3V to +0.3V	Operating Temperature Range	-40 $^\circ\text{C}$ to +85 $^\circ\text{C}$
DL_ to PGND	-0.3V to OUTSU + 0.3V	Junction Temperature	+150 $^\circ\text{C}$
LXSU Current (Note 1)	3.6A	Storage Temperature Range	-65 $^\circ\text{C}$ to +150 $^\circ\text{C}$
LXSD Current (Note 1)	2.25A	Lead Temperature (soldering, 10s)	+300 $^\circ\text{C}$
REF, OSC, COMP_ to GND	-0.3V to OUTSU + 0.3V		

Note 1: LXSU has internal clamp diodes to OUTSU and PGND, and LXSD has internal clamp diodes to INSD and PGND. Applications that forward bias these diodes should take care not to exceed the devices power dissipation limits.

Stresses beyond those listed under "Absolute Maximum Ratings" may cause permanent damage to the device. These are stress ratings only, and functional operation of the device at these or any other conditions beyond those indicated in the operational sections of the specifications is not implied. Exposure to absolute maximum rating conditions for extended periods may affect device reliability.

ELECTRICAL CHARACTERISTICS

($V_{\text{OUTSU}} = 3.3\text{V}$, $T_A = 0^\circ\text{C}$ to $+85^\circ\text{C}$, unless otherwise noted.)

PARAMETER	CONDITIONS	MIN	TYP	MAX	UNITS
GENERAL					
Input Voltage Range	(Note 2)	0.7		5.5	V
Minimum Startup Voltage	$I_{\text{LOAD}} < 1\text{mA}$, $T_A = +25^\circ\text{C}$, startup voltage tempco is -2300ppm/ $^\circ\text{C}$ (typ) (Note 3)		0.9	1.1	V
Overload Protection Fault Interval			100,000		OSC cycles
Thermal Shutdown			160		$^\circ\text{C}$
Thermal-Shutdown Hysteresis			20		$^\circ\text{C}$
Shutdown Supply Current into OUTSU	$\text{ONSU} = \text{ONSD} = \text{ON1} = \text{ON2} = \text{ON3} = 0$; $\text{OUTSU} = 3.6\text{V}$		0.1	5	μA
Step-Up DC-to-DC Supply Current into OUTSU	$\text{ONSU} = 3.35\text{V}$, $\text{FBSU} = 1.5\text{V}$ (does not include switching losses)		290	400	μA
Step-Up Plus 1 AUX Supply Current into OUTSU	$\text{ONSU} = \text{ON}_- = 3.35\text{V}$, $\text{FBSU} = 1.5\text{V}$, $\text{FB}_- = 1.5\text{V}$ (does not include switching losses)		420	600	μA
Step-Up Plus Step-Down Supply Current into OUTSU	$\text{ONSU} = \text{ONSD} = 3.35\text{V}$, $\text{FBSU} = 1.5\text{V}$, $\text{FBSD} = 1.5\text{V}$ (does not include switching losses)		470	650	μA
Reference Output Voltage	$I_{\text{REF}} = 20\mu\text{A}$	1.23	1.25	1.27	V
Reference Load Regulation	$10\mu\text{A} < I_{\text{REF}} < 200\mu\text{A}$		4.5	10	mV
Reference Line Regulation	$2.7 < \text{OUTSU} < 5.5\text{V}$		1.3	5	mV
OSC Discharge Trip Level	Rising edge	1.225	1.25	1.275	V
OSC Discharge Resistance	$\text{OSC} = 1.5\text{V}$, $I_{\text{OSC}} = 3\text{mA}$		52	80	Ω
OSC Discharge Pulse Width			300		ns
OSC Frequency	$R_{\text{OSC}} = 40\text{k}\Omega$, $C_{\text{OSC}} = 100\text{pF}$		400		kHz
STEP-UP DC-TO-DC CONVERTER					
Step-Up Startup-to-Normal Operating Threshold	Rising or falling edge (Note 4)	2.30	2.5	2.60	V
Step-Up Startup-to-Normal Operating Threshold Hysteresis			80		mV

Small, High-Efficiency, Five-Channel Digital Still Camera Power Supply

MAX1565

ELECTRICAL CHARACTERISTICS (continued)

($V_{OUTSU} = 3.3V$, $T_A = 0^{\circ}C$ to $+85^{\circ}C$, unless otherwise noted.)

PARAMETER	CONDITIONS	MIN	TYP	MAX	UNITS
Step-Up Voltage Adjust Range		2.7		5.5	V
FBSU Regulation Voltage		1.231	1.25	1.269	V
OUTSU Regulation Voltage	FBSELSU = GND	3.296	3.35	3.404	V
FBSU to COMPSU Transconductance	FBSU = COMPSU	80	135	185	μS
FBSU Input Leakage Current	FBSU = 1.25V	-100	+1	+100	nA
Idle-Mode™ Trip Level	(Note 6)	150	200	265	mA
Current-Sense Amplifier Transresistance			0.3		V/A
Step-Up Maximum Duty Cycle	FBSU = 1V	80	85	90	%
OUTSU Leakage Current	$V_{LX} = 0V$, $V_{OUTSU} = 5.5V$		0.01	20	μA
LXSU Leakage Current	$V_{LXSU} = V_{OUT} = 5.5V$		0.01	20	μA
Switch On-Resistance	N-channel		95	150	$m\Omega$
	P-channel		150	250	
N-Channel Current limit		1.6	2	2.4	A
P-Channel Turn-Off Current			20		mA
Startup Current Limit	$V_{OUTSU} = 1.8V$ (Note 5)		800		mA
Startup t_{OFF}	$V_{OUTSU} = 1.8V$		700		ns
Startup Frequency	$V_{OUTSU} = 1.8V$		200		kHz
STEP-DOWN DC-TO-DC CONVERTER					
FBSD Regulation Voltage		1.231	1.25	1.269	V
OUTSD Regulation Voltage	FBSELSD = GND	1.48	1.5	1.52	V
FBSD to COMPSD Transconductance	FBSD = COMPSD	80	135	185	μS
FBSD Input Leakage Current	FBSD = 1.25V	-100	+1	+100	nA
Idle-Mode Trip Level	(Note 6)	110	160	190	mA
Current-Sense Amplifier Transresistance			0.60		V/A
LXSD Leakage Current	$V_{LXSD} = 5.5V$, $V_{OUTSU} = 5.5V$		0.01	20	μA
	$V_{LXSD} = 0V$, $V_{OUTSU} = 5.5V$		0.01	20	
Switch On-Resistance	N-channel		95	150	$m\Omega$
	P-channel		150	250	
P-Channel Current Limit		0.7	0.79	1.0	A
N-Channel Turn-Off Current			20		mA
Soft-Start Interval			4096		OSC cycles
SDOK Output Low Voltage	FBSD = 0.4V; 0.1mA into SDOK pin		0.002	0.1	V
SDOK Operating Voltage Range		1.0		5.5	V

Idle Mode is a trademark of Maxim Integrated Products, Inc.

Small, High-Efficiency, Five-Channel Digital Still Camera Power Supply

ELECTRICAL CHARACTERISTICS (continued)

($V_{OUTSU} = 3.3V$, $T_A = 0^{\circ}C$ to $+85^{\circ}C$, unless otherwise noted.)

PARAMETER	CONDITIONS	MIN	TYP	MAX	UNITS
AUXILIARY DC-TO-DC CONTROLLERS (AUX 1, 2, AND 3)					
Maximum Duty Cycle	FB_ = 1V	80	85	90	%
FB_ Regulation Voltage	FB_ = COMP_	1.231	1.25	1.269	V
FB_ to COMP_ Transconductance	FB_ = COMP_	80	135	185	μS
FB_ Input Leakage Current	FB_ = 1.25V	-100	+1	+100	nA
AUX1 Output Regulation Voltage	FBSEL1 = GND, FB1 connected directly to AUX1 output	4.93	5	5.07	V
DL_ Driver Resistance	Output high		3	10	Ω
	Output low		2	5	
DL_ Drive Current	Sourcing or sinking		0.5		A
Soft-Start Interval			4096		OSC cycles
LOGIC INPUTS (ON_ , FBSEL_)					
Input Low Level	1.1V < OUTSU < 1.8V (ONSU only)			0.2	V
	1.8V < OUTSU < 5.5V			0.4	
Input High Level	1.1V < OUTSU < 1.8V (ONSU only)	$V_{OUTSU} - 0.2$			V
	1.8V < OUTSU < 5.5V	1.6			
FBSEL_ Input Leakage Current	FBSEL = 3.6V, OUTSU = 3.6V	-100	0	+100	nA
	FBSEL = GND, OUTSU = 3.6V	-100	0	+100	
ON_ Impedance to GND	ON_ = 3.35V		330		k Ω

ELECTRICAL CHARACTERISTICS

($V_{OUTSU} = 3.3V$, $T_A = -40^{\circ}C$ to $+85^{\circ}C$, unless otherwise noted.)

PARAMETER	CONDITIONS	MIN	TYP	MAX	UNITS
GENERAL					
Input Voltage Range	(Note 2)	0.7		5.5	V
Minimum Startup Voltage	$I_{LOAD} < 1mA$, $T_A = +25^{\circ}C$, startup voltage tempco is $-2300ppm/^{\circ}C$ (typ) (Note 3)			1.1	V
Shutdown Supply Current into OUTSU	ONSU = ONSD = ON1 = ON2 = ON3 = 0 OUTSU = 3.6V			5	μA
Step-Up DC-to-DC Supply Current into OUTSU	ONSU = 3.35V, FBSU = 1.5V (does not include switching losses)			400	μA
Step-Up Plus 1 AUX Supply Current into OUTSU	ONSU = ON_ = 3.35V, FBSU = 1.5V, FB_ = 1.5V (does not include switching losses)			600	μA
Step-Up Plus Step-Down Supply Current into OUTSU	ONSU = ONSD = 3.35V, FBSU = 1.5V, FBSD = 1.5V (does not include switching losses)			650	μA
Reference Output Voltage	$I_{REF} = 20\mu A$	1.23		1.27	V
Reference Load Regulation	$10\mu A < I_{REF} < 200\mu A$			10	mV

Small, High-Efficiency, Five-Channel Digital Still Camera Power Supply

MAX1565

ELECTRICAL CHARACTERISTICS (continued)

($V_{OUTSU} = 3.3V$, $T_A = -40^{\circ}C$ to $+85^{\circ}C$, unless otherwise noted.)

PARAMETER	CONDITIONS	MIN	TYP	MAX	UNITS
Reference Line Regulation	$2.7V < OUTSU < 5.5V$			5	mV
OSC Discharge Trip Level	Rising edge	1.225		1.275	V
OSC Discharge Resistance	OSC = 1.5V, $I_{OSC} = 3mA$			80	Ω
STEP-UP DC-TO-DC CONVERTER					
Step-Up Startup-to-Normal Operating Threshold	Rising or falling edge (Note 4)	2.30		2.60	V
Step-Up Voltage Adjust Range		2.7		5.5	V
FBSU Regulation Voltage		1.225		1.275	V
OUTSU Regulation Voltage	FBSELSU = GND	3.283		3.417	V
FBSU to COMPSU Transconductance	FBSU = COMPSU	80		185	μS
FBSU Input Leakage Current	FBSU = 1.25V	-100		+100	nA
Idle-Mode Trip Level	(Note 6)	150		275	mA
Step-Up Maximum Duty Cycle	FBSU = 1V	80		90	%
OUTSU Leakage Current	$V_{LX} = 0V$, $OUTSU = 5.5V$			20	μA
LXSU Leakage Current	$V_{LXSU} = V_{OUT} = 5.5V$			20	μA
Switch On-Resistance	N-channel			150	m Ω
	P-channel			250	
N-Channel Current limit		1.6		2.4	A
STEP-DOWN DC-TO-DC CONVERTER					
FBSD Regulation Voltage		1.225		1.275	V
OUTSD Regulation Voltage	FBSELSD = GND	1.47		1.53	V
FBSD to COMPSD Transconductance	FBSD = COMPSD	80		185	μS
FBSD Input Leakage Current	FBSD = 1.25V	-100		+100	nA
Idle-Mode Trip Level	(Note 6)	110		195	mA
LXSD Leakage Current	$V_{LXSD} = 5.5V$, $OUTSU = 5.5V$			20	μA
	$V_{LXSD} = 0V$, $OUTSU = 5.5V$			20	
Switch On-Resistance	N-channel			150	m Ω
	P-channel			250	
P-Channel Current Limit		0.7		1.0	A
SDOK Output Low Voltage	FBSD = 0.4V; 0.1mA into SDOK pin			0.1	V
SDOK Operating Voltage Range		1		5.5	V
AUXILIARY DC-TO-DC CONTROLLERS (AUX 1, 2, AND 3)					
Maximum Duty Cycle	FB_ = 1V	80		90	%
FB_ Regulation Voltage	FB_ = COMP_	1.225		1.275	V

Small, High-Efficiency, Five-Channel Digital Still Camera Power Supply

ELECTRICAL CHARACTERISTICS (continued)

($V_{OUTSU} = 3.3V$, $T_A = -40^{\circ}C$ to $+85^{\circ}C$, unless otherwise noted.)

PARAMETER	CONDITIONS	MIN	TYP	MAX	UNITS
FB_ to COMP_ Transconductance	FB_ = COMP_	80		185	μS
FB_ Input Leakage Current	FB_ = 1.25V	-100		+100	nA
AUX1 Output Regulation Voltage	FBSEL1 = GND, FB1 connected directly to AUX1 output	4.90		5.10	V
DL_ Driver Resistance	Output high			10	Ω
	Output low			5	
LOGIC INPUTS (ON_, FBSEL_)					
Input Low Level	1.1V < V_{OUTSU} < 1.8V (ONSU only)			0.2	V
	1.8V < V_{OUTSU} < 5.5V			0.4	
Input High Level	1.1V < V_{OUTSU} < 1.8V (ONSU only)	V_{OUTSU}		-0.2	V
	1.8V < V_{OUTSU} < 5.5V	1.6			
FBSEL_ Input Leakage Current	FBSEL = 3.6V, $V_{OUTSU} = 3.6V$	-100		+100	nA
	FBSEL = GND, $V_{OUTSU} = 3.6V$	-100		+100	

Note 2: The IC is powered from the V_{OUTSU} output.

Note 3: Since the part is powered from V_{OUTSU} , a Schottky rectifier, connected from the input battery to V_{OUTSU} , is required for low-voltage startup.

Note 4: The step-up regulator operates in startup mode until this voltage is reached. Do not apply full load current during startup.

Note 5: The step-up current limit in startup refers to the LXSU switch current limit, not an output current limit.

Note 6: The idle-mode current threshold is the transition point between fixed-frequency PWM operation and idle-mode operation (where switching rate varies with load). The spec is given in terms of inductor current. In terms of output current, the idle-mode transition varies with input/output voltage ratio and inductor value. For the step-up, the transition output current is approximately 1/3 the inductor current when stepping from 2V to 3.3V. For the step-down, the transition current in terms of output current is approximately 3/4 the inductor current when stepping down from 3.3V to 1.8V.

Typical Operating Characteristics

(Circuit of Figure 1, $T_A = +25^{\circ}C$, unless otherwise noted.)

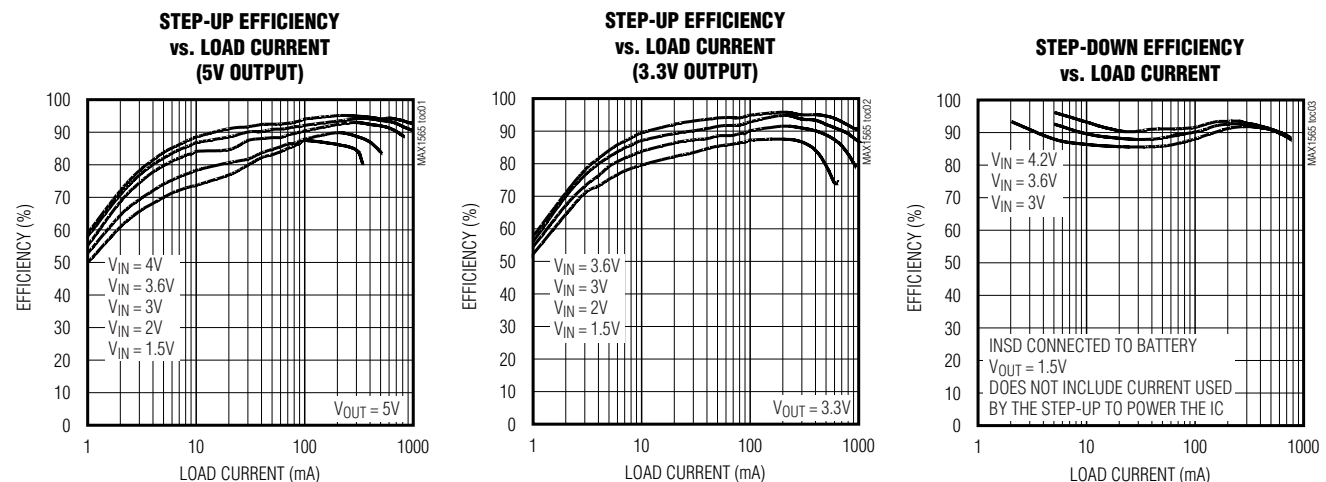

Small, High-Efficiency, Five-Channel Digital Still Camera Power Supply

MAX1565

Typical Operating Characteristics (continued)

(Circuit of Figure 1, $T_A = +25^\circ\text{C}$, unless otherwise noted.)

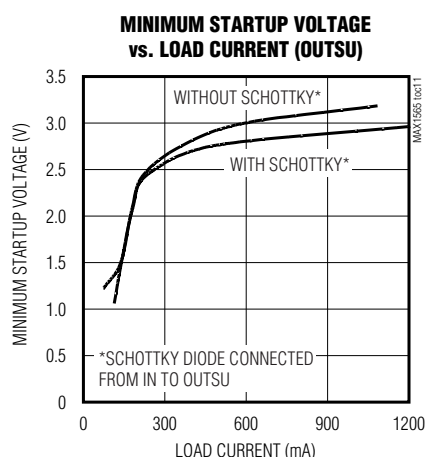
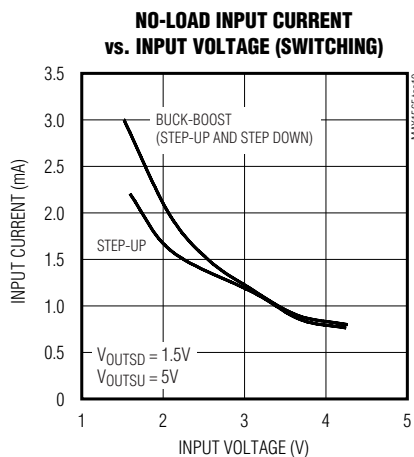
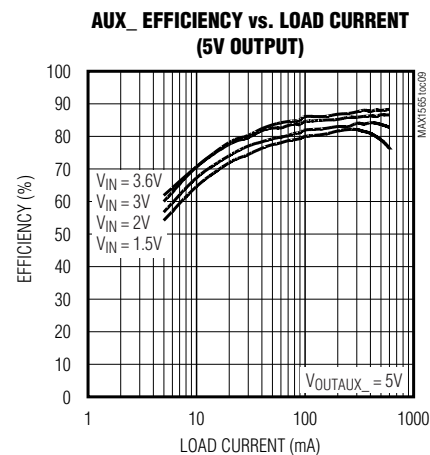
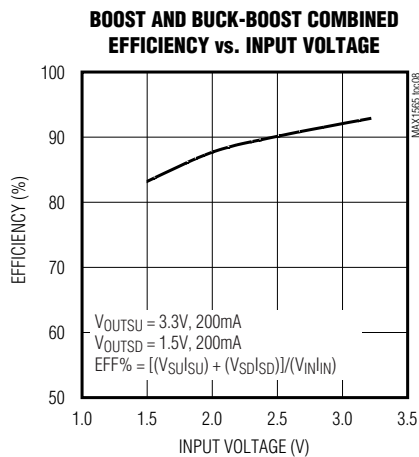
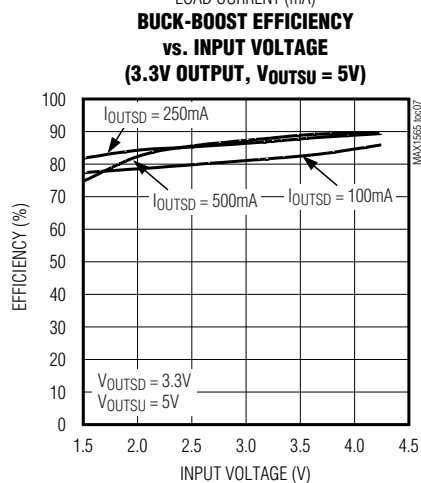
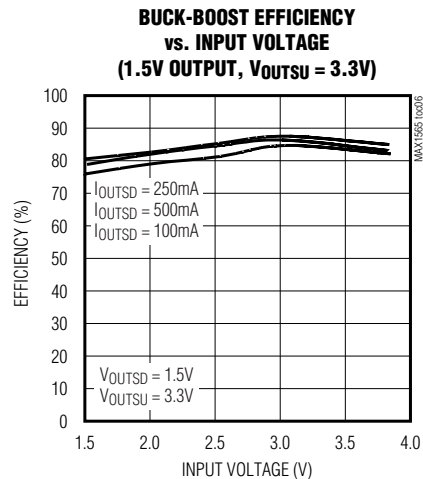
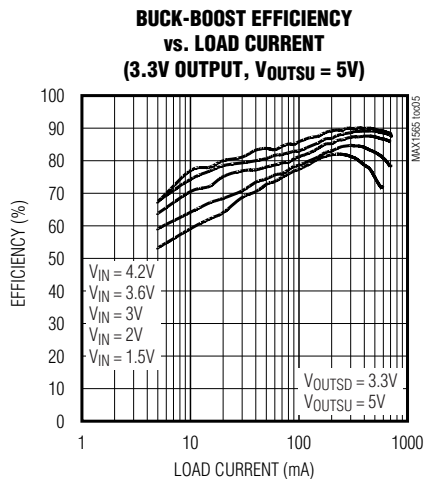
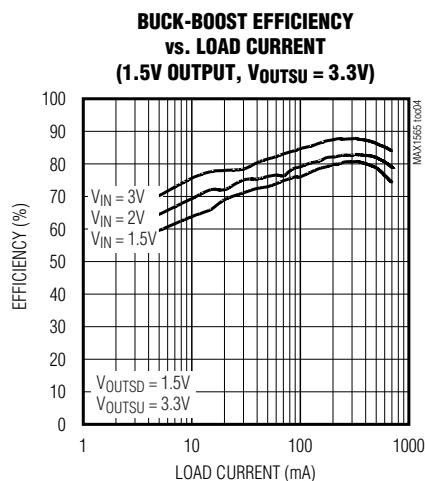

Small, High-Efficiency, Five-Channel Digital Still Camera Power Supply

Typical Operating Characteristics (continued)

(Circuit of Figure 1, $T_A = +25^\circ\text{C}$, unless otherwise noted.)

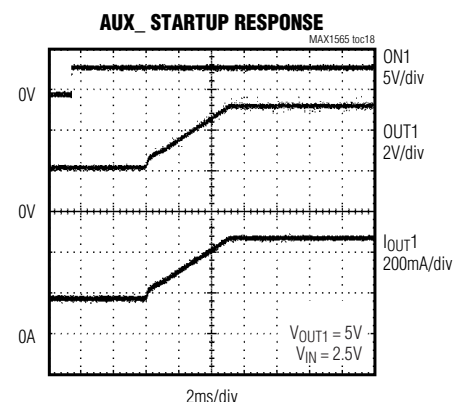
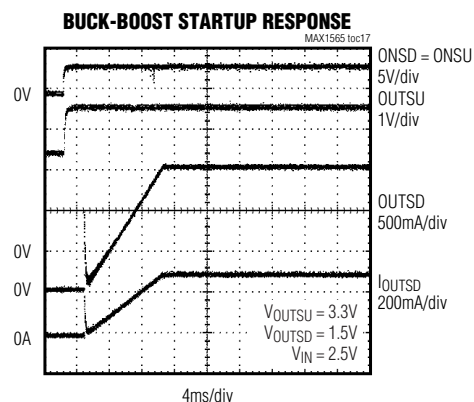
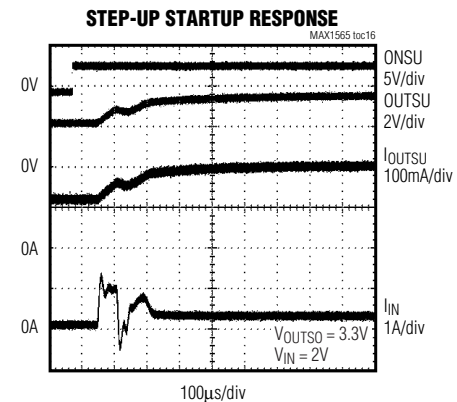
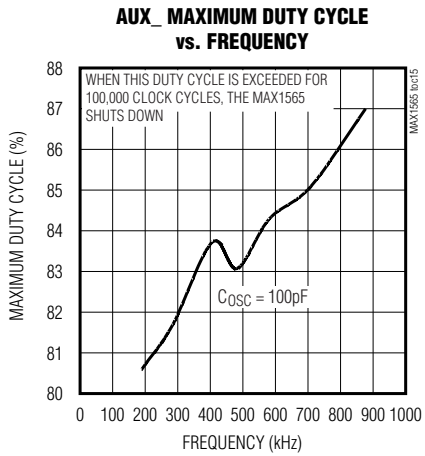
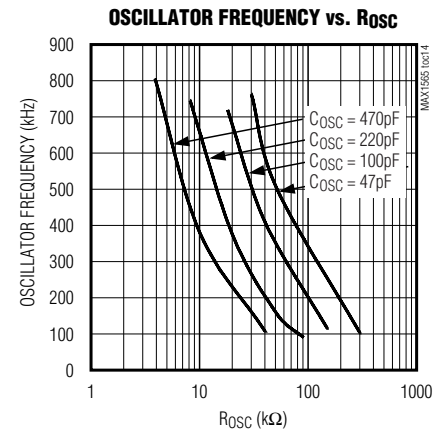
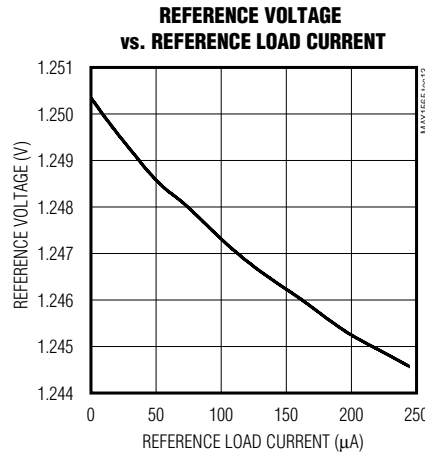
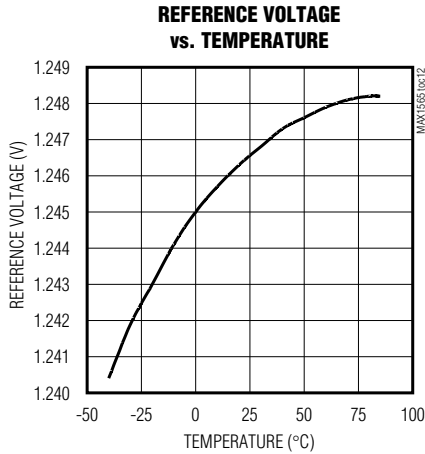

Small, High-Efficiency, Five-Channel Digital Still Camera Power Supply

Typical Operating Characteristics (continued)

(Circuit of Figure 1, $T_A = +25^\circ\text{C}$, unless otherwise noted.)

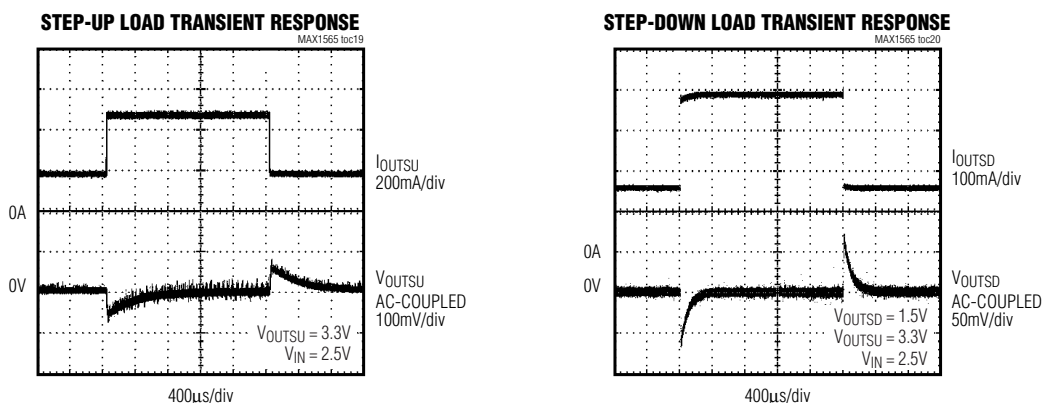

MAX1565

Pin Description

PIN	NAME	FUNCTION
1	COMP1	Auxiliary Controller 1 Compensation Node. Connect a series RC from COMP1 to GND to compensate the control loop. COMP1 is actively driven to GND in shutdown and thermal limit.
2	FB1	Auxiliary Controller 1 Feedback Input. For 5V output, short FBSEL1 to GND and connect FB1 to the output voltage. For other output voltages, connect FBSEL1 to OUTSU and connect a resistive voltage-divider from the step-up converter output to FB1 to GND. The FB1 feedback threshold is then 1.25V. This pin is high impedance in shutdown.
3	PGNDA	Power Ground. Connect PGNDA and PGND B together and to GND with short trace as close to the IC as possible.
4	LXSD	Step-Down Converter Power-Switching Node. Connect LXSD to the step-down converter inductor. LXSD is the drain of the P-channel switch and N-channel synchronous rectifier. LXSD is high impedance in shutdown.
5	INSD	Step-Down Converter Input. INSD can connect to OUTSU, effectively making OUTSD a buck-boost output from the battery. Bypass to GND with a 1µF ceramic capacitor if connected to OUTSU. INSD may also be connected to the battery, but should not exceed OUTSU by more than a Schottky diode forward voltage. Bypass INSD with a 10µF ceramic capacitor when connecting to the battery input. A 10kΩ internal resistance connects OUTSU and INSD.
6	ONSD	Step-Down Converter On/Off Control Input. Drive ONSD high to turn on the step-down converter. This pin has an internal 330kΩ pulldown resistor. ONSD does not start until OUTSU is in regulation.
7	COMPSD	Step-Down Converter Compensation Node. Connect a series RC from COMPSD to GND to compensate the control loop. COMPSD is pulled to GND in normal shutdown and during thermal shutdown (see the <i>Step-Down Compensation</i> section).

Small, High-Efficiency, Five-Channel Digital Still Camera Power Supply

Pin Description (continued)

PIN	NAME	FUNCTION
8	FBSD	Step-Down Converter Feedback Input. For a 1.5V output, short FBSELS to GND and connect FBSD to OUTSD. For other voltages, short FBSELS to OUTSU and connect a resistive voltage-divider from OUTSD to FBSD to GND. The FBSD feedback threshold is 1.25V. This pin is high impedance in shutdown.
9	ON1	Auxiliary Controller 1 On/Off Control Input. Drive ON1 high to turn on. This pin has an internal 330k Ω pulldown resistor. ON1 cannot start until OUTSU is in regulation.
10	ON2	Auxiliary Controller 2 On/Off Control Input. Drive ON2 high to turn on. This pin has an internal 330k Ω pulldown resistor. ON2 cannot start until OUTSU is in regulation.
11	ON3	Auxiliary Controller 3 On/Off Control Input. Drive ON3 high to turn on. This pin has an internal 330k Ω pulldown resistor. ON3 cannot start until OUTSU is in regulation.
12	ONSU	Step-Up Converter On/Off Control. Drive ONSU high to turn on the step-up converter. All other control pins are locked out until 2ms after the step-up output has reached its final value. This pin has an internal 330k Ω resistance to GND.
13	REF	Reference Output. Bypass REF to GND with a 0.1 μ F or greater capacitor. The maximum allowed load on REF is 200 μ A. REF is actively pulled to GND when all converters are shut down.
14	FBSU	Step-Up Converter Feedback Input. To regulate OUTSU to 3.35V, connect FBSELSU to GND. FBSU may be connected to OUTSU or GND. For other output voltages, connect FBSELSU to OUTSU and connect a resistive voltage-divider from OUTSU to FBSU to GND. The FBSU feedback threshold is 1.25V. This pin is high impedance in shutdown.
15	COMPUSU	Step-Up Converter Compensation Node. Connect a series RC from COMPUSU to GND to compensate the control loop. COMPUSU is pulled to GND in normal shutdown and during thermal shutdown (see the <i>Step-Down Compensation</i> section).
16	FBSELSU	Step-Up Feedback Select Pin. With FBSELSU = GND, OUTSU regulates to 3.35V. With FBSELSU = OUTSU, FBSU regulates to a 1.25V threshold for use with external feedback resistors. This pin is high impedance in shutdown.
17	FBSELSD	Step-Down Feedback Select Pin. With FBSELSD = GND, FBSD regulates to 1.5V. With FBSELSD = OUTSU, FBSD regulates to 1.25V for use with external feedback resistors. This pin is high impedance in shutdown.
18	FBSEL1	Auxiliary Controller 1 Feedback Select Pin. With FBSEL1 = GND and FB1 regulates to 5V. With FBSEL1 = OUTSU, FB1 regulates to 1.25V for use with external feedback resistors. This pin is high impedance in shutdown.
19	OSC	Oscillator Control. Connect a timing capacitor from OSC to GND and a timing resistor from OSC to OUTSU to set the oscillator frequency between 100kHz and 1MHz. This pin is high impedance in shutdown.
20	PGNDB	Power Ground. Connect PGNDA and PGNDB together and to GND with short trace as close to the IC as possible.
21	LXSU	Step-Up Converter Power-Switching Node. Connect LXSU to the step-up converter inductor. LXSU is high impedance in shutdown.
22	OUTSUA	Step-Up Converter Output. OUTSUA is the power output of the step-up converter. Connect OUTSUA to OUTSUB at the IC.
23	SDOK	This open-drain output goes high impedance when the step-down has successfully completed soft-start.

Small, High-Efficiency, Five-Channel Digital Still Camera Power Supply

Pin Description (continued)

MAX1565

PIN	NAME	FUNCTION
24	COMP3	Auxiliary Controller 3 Compensation Node. Connect a series resistor-capacitor from COMP3 to GND to compensate the control loop. COMP3 is actively driven to GND in shutdown and thermal limit.
25	FB3	Auxiliary Controller 3 Feedback Input. Connect a resistive voltage-divider from the output voltage to FB3 to GND. The FB3 feedback threshold is 1.25V. This pin is high impedance in shutdown.
26	OUTSUB	Step-Up Converter Output. OUTSUB powers the MAX1565 and is the sense input when FBSELSU is GND and the output is 3.3V. Connect OUTSUA to OUTSUB.
27	DL3	Auxiliary Controller 3 Gate-Drive Output. Connect the gate of an N-channel MOSFET to DL3. DL3 swings from GND to OUTSU and supplies up to 500mA. DL3 is driven to GND in shutdown and thermal limit.
28	DL2	Auxiliary Controller 2 Gate-Drive Output. Connect the gate of an N-channel MOSFET to DL2. DL2 swings from GND to OUTSU and supplies up to 500mA. DL2 is driven to GND in shutdown and thermal limit.
29	DL1	Auxiliary Controller 1 Gate-Drive Output. Connect the gate of an N-channel MOSFET to DL1. DL1 swings from GND to OUTSU and supplies up to 500mA. DL1 is driven to GND in shutdown and thermal limit.
30	GND	Quiet Ground. Connect GND to PGND as close to the IC as possible.
31	COMP2	Auxiliary Controller 2 Compensation Node. Connect a series resistor-capacitor from COMP2 to GND to compensate the control loop. COMP2 is actively driven to GND in shutdown and thermal limit.
32	FB2	Auxiliary Controller 2 Feedback Input. Connect a resistive voltage-divider from the output voltage to FB2 to GND to set the output voltage. The FB2 feedback threshold is 1.25V. This pin is high impedance in shutdown.
Exposed Pad	EP	Exposed Underside Metal Pad. This pad must be soldered to the PC board to achieve package thermal and mechanical ratings. The exposed pad is electrically connected to GND.

Small, High-Efficiency, Five-Channel Digital Still Camera Power Supply

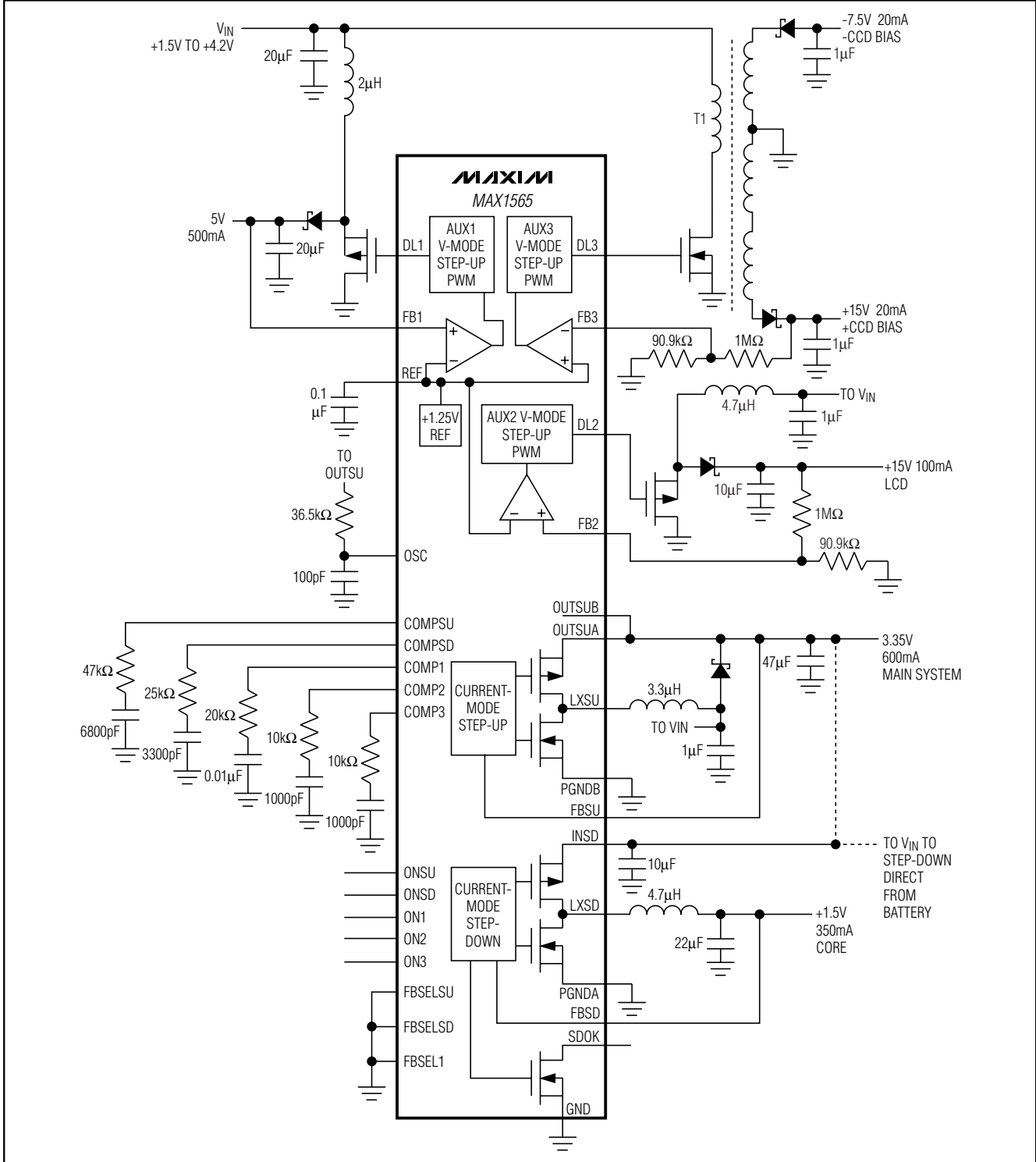

Figure 1. Typical Application Circuit

Small, High-Efficiency, Five-Channel Digital Still Camera Power Supply

MAX1565

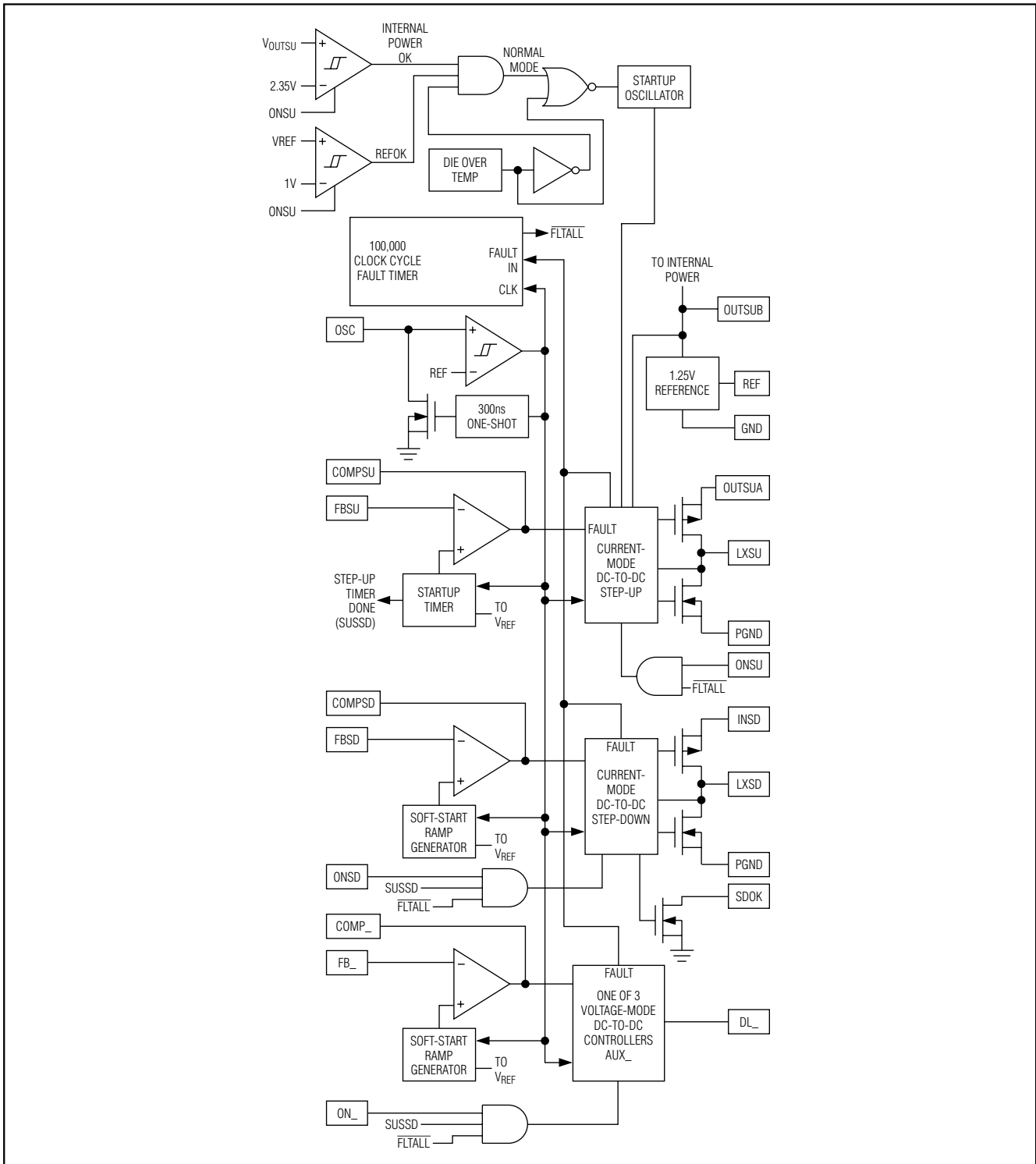

Figure 2. MAX1565 Functional Diagram

Small, High-Efficiency, Five-Channel Digital Still Camera Power Supply

Detailed Description

The MAX1565 is a complete digital still camera power-conversion IC. It can accept input from a variety of sources including single-cell Li+ batteries, 2-cell alkaline or NiMH batteries, as well as systems designed to accept both battery types. The MAX1565 includes five DC-to-DC converter channels to generate all required voltages:

- 1) **Synchronous rectified step-up DC-to-DC converter with on-chip MOSFETs**—This typically supplies 3.3V for main system power.
- 2) **Synchronous rectified step-down DC-to-DC converter with on-chip MOSFETs**—Powering the step-down from the step-up output provides efficient (up to 90%) buck-boost functionality that supplies a regulated output when the battery voltage is above or below the output voltage. The step-down can also be powered from the battery.
- 3) **Auxiliary DC-to-DC Controller 1**—Typically used for 5V output for motor, strobe, or other functions as required.
- 4) **Auxiliary DC-to-DC Controller 2**—Typically supplies LCD bias voltages with either a multi-output flyback transformer, or boost converter with charge-pump inverter. Alternately may power white LEDs for LCD backlighting.
- 5) **Auxiliary DC-to-DC Controller 3**—Typically supplies CCD bias voltages with either a multi-output flyback transformer, or boost converter with charge-pump inverter.

The MAX1565 can also operate with MAX1801 slave DC-to-DC controllers if additional DC-to-DC converter channels are required. All MAX1565 DC-to-DC converter channels employ fixed-frequency PWM operation.

In addition to multiple DC-to-DC channels, the MAX1565 also includes overload protection, soft-start circuitry, adjustable PWM operating frequency, and a power-OK (POK) output to signal when the step-down converter output voltage (for CPU core) is in regulation.

Step-Up DC-to-DC Converter

The step-up DC-to-DC converter channel generates a 2.7V to 5.5V output voltage range from a 0.9V to 5.5V battery input voltage. An internal switch and synchronous rectifier allow conversion efficiencies as high as 95% while reducing both circuit size and the number of external components. Under moderate to heavy loading, the converter operates in a low-noise PWM mode with constant frequency. Switching harmonics generated by fixed-frequency operation are consistent and easily filtered.

The step-up is a current-mode PWM. An error signal (at COMPSU) represents the difference between the feedback voltage and the reference. The error signal programs the inductor current to regulate the output voltage. At light loads (under 75mA when boosting from 2V to 3.3V), efficiency is enhanced by an idle mode in which switching occurs only as needed to service the load. In this mode, the inductor current peak is limited to typically 200mA for each pulse.

Step-Down DC-to-DC Converter

The step-down DC-to-DC converter channel is optimized for generating output voltages down to 1.25V. Lower output voltages can be set by adding an additional resistor (see the *Applications Information* section). An internal switch and synchronous rectifier allow conversion efficiencies as high as 95% while reducing both circuit size and the number of external components. Under moderate to heavy loading, the converter operates in a low-noise PWM mode with constant frequency. Switching harmonics generated by fixed-frequency operation are consistent and easily filtered.

The step-down is a current-mode PWM. An error signal (at COMPSD) represents the difference between the feedback voltage and the reference. The error signal programs the inductor current to regulate the output voltage. At light loads (under 120mA), efficiency is enhanced by an idle mode in which switching occurs only as needed to service the load. In this mode, the inductor current peak is limited to 150mA (typ) for each pulse.

The step-down remains inactive until the step-up DC-to-DC is in regulation. This means that the step-down DC-to-DC on/off pin (ONSD) is overridden by ONSU. The soft-start sequence for the step-down begins 1024 OSC cycles after the step-up output is in regulation. If the step-up, step-down, or any of the auxiliary controllers remains faulted for 200ms, all channels turn off. The step-down also features an open-drain SDOK output that goes low when the output is in regulation.

Buck-Boost Operation

The step-down input can be powered from the output of the step-up. By cascading these two channels, the step-down output can maintain regulation even as the battery voltage falls below the step-down output voltage. This is especially useful when trying to generate 3.3V from 1-cell Li+ inputs, or 2.5V from 2-cell alkaline or NiMH inputs, or when designing a power supply that must operate from both Li+ and alkaline/NiMH inputs. Compound efficiencies of up to 90% can be achieved when the step-up and step-down are operated in series.

Small, High-Efficiency, Five-Channel Digital Still Camera Power Supply

Note that the step-up output supplies both the step-up load and the step-down input current when the step-down is powered from the step-up. The step-down input current reduces the available step-up output current for other loads.

Direct Battery Step-Down Operation

The step-down converter can also be operated directly from the battery as long as the voltage at INSD does not exceed OUTSU by more than a Schottky diode forward voltage. When using this connection, connect a Schottky diode from the battery input to OUTSU. There is also an internal 10kΩ resistance from OUTSU to INSD, which adds a small additional current drain (of approximately $(V_{OUTSU} - V_{INSD})/10k\Omega$ from OUTSU when INSD is not connected directly to OUTSU.

Step-down direct battery operation improves efficiency for the step-down output (up to 95%), but limits the upper limit of the output voltage to 200mV less than the minimum battery voltage. In 1-cell Li+ designs (with a 2.7V min), the output can be set up to 2.5V. In 2-cell alkaline or NiMH designs, the output may be limited to 1.5V or 1.8V, depending on the minimum allowed cell voltage.

The step-down can only be briefly operated in dropout since the MAX1565 fault protection detects the out-of-regulation condition and activates after 100,000 OSC cycles, or 200ms at 500kHz. At that point, all MAX1565 channels shut down.

Auxiliary DC-to-DC Controllers

The three auxiliary controllers operate as fixed-frequency voltage-mode PWM controllers. They do not have internal MOSFETs, so output power is determined by external components. The controllers regulate output voltage by modulating the pulse width of the DL_ drive signal to an external N-channel MOSFET switch.

Figure 3 shows a functional diagram of an AUX controller channel. A sawtooth oscillator signal at OSC governs timing. At the start of each cycle, DL_ goes high, turning on the external N-FET switch. The switch then turns off when the internally level-shifted sawtooth rises above COMP_ or when the maximum duty cycle is exceeded. The switch remains off until the start of the next cycle. A transconductance error amplifier forms an integrator at COMP_ so that DC high-loop gain and accuracy can be maintained.

The auxiliary controllers do not start until the step-up DC-to-DC output is in regulation. If the step-up, step-down, or any of the auxiliary controllers remains faulted for 100,000 OSC cycles, then all MAX1565 channels latch off.

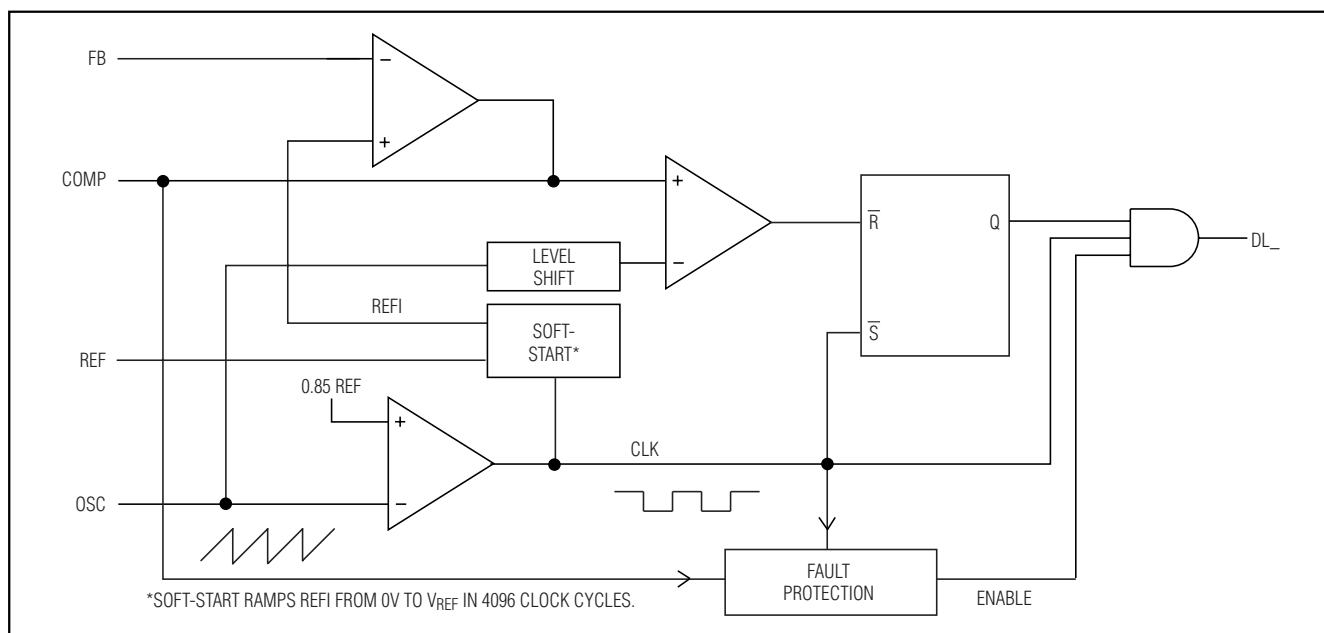

Figure 3. PWM Auxiliary Controller Functional Diagram

Small, High-Efficiency, Five-Channel Digital Still Camera Power Supply

Maximum Duty Cycle

The MAX1565 auxiliary PWM controllers have a guaranteed maximum duty cycle of 80%. That is to say that all controllers can achieve at least 80% and typically reach 85%. In boost designs that employ continuous current, the maximum duty cycle limits the boost ratio such that:

$$1 - V_{IN}/V_{OUT} \leq 80\%$$

With discontinuous inductor current, no such limit exists for the input/output ratio since the inductor has time to fully discharge before the next cycle begins.

Master/Slave Configurations

The MAX1565 supports MAX1801 slave PWM controllers that obtain input power, a voltage reference, and an oscillator signal directly from the MAX1565 master. The master/slave configuration allows channels to be easily added and minimizes system cost by eliminating redundant circuitry. The slaves also control the harmonic content of noise since their operating frequency is synchronized to that of the MAX1565 master converter. A MAX1801 connection to the MAX1565 is shown in Figure 11.

Fault Protection

The MAX1565 has robust fault and overload protection. After power-up, the device is set to detect an out-of-regulation state that could be caused by an overload or short. If any DC-to-DC converter channel (step-up, step-down, or any of the auxiliary controllers) remains faulted for 100,000 clock cycles, then ALL outputs latch off until the step-up DC-to-DC converter is reinitialized by the ONSU pin, or by cycling of input power. The fault-detection circuitry for any channel is disabled during its initial turn-on soft-start sequence.

Note that output of the step-up, or that of any auxiliary channel set up in boost configuration, does not fall to 0V during shutdown or fault. This is due to the current path from the battery to the output that remains even when the channel is off. This path exists through the boost inductor and the synchronous rectifier body diode. OUTSU falls to the input voltage minus the synchronous rectifier body diode drop during shutdown, and also during fault if the input voltage exceeds 2.5V. If the input voltage is less than 2.5V, OUTSU remains at 2.5V due to operation of the startup oscillator, but can source only limited current.

Reference

The MAX1565 has an internal 1.250V reference. Connect a 0.1µF ceramic bypass capacitor from REF to GND within 0.2in (5mm) of the REF pin. REF can source up to 200µA and is enabled whenever ONSD is high and OUTSD is above 2.5V. The auxiliary controllers and MAX1801 slave controllers (if connected) each sink up to 30µA REF current during startup. If the application requires that REF be loaded beyond 200µA, it may be buffered with a unity-gain amplifier or op amp.

Oscillator

All MAX1565 DC-to-DC converter channels employ fixed-frequency PWM operation. The operating frequency is set by an RC network at the OSC pin. The range of usable settings is 100kHz to 1MHz. When MAX1801 slave controllers are added, they operate at the same frequency set by OSC.

The oscillator uses a comparator, a 300ns one-shot, and an internal N-FET switch in conjunction with an external timing resistor and capacitor (Figure 4). When the switch is open, the capacitor voltage exponentially approaches the step-up output voltage from zero with a time constant given by the $R_{OSC}C_{OSC}$ product. The comparator output switches high when the capacitor voltage reaches V_{REF} (1.25V). In turn, the one-shot activates the internal MOSFET switch to discharge the capacitor within a 300ns interval, and the cycle repeats. Note that the oscillation frequency changes as the main output voltage ramps upward following startup. The oscillation frequency is constant once the main output is in regulation.

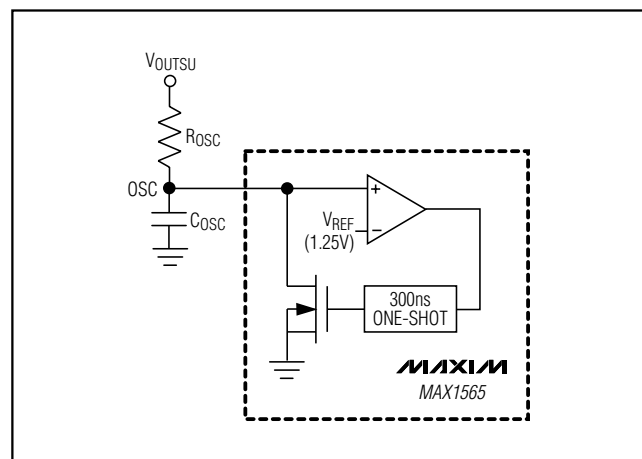

Figure 4. Master Oscillator

Small, High-Efficiency, Five-Channel Digital Still Camera Power Supply

Low-Voltage Startup Oscillator

The MAX1565 internal control and reference-voltage circuitry receive power from OUTSU and do not function when OUTSU is less than 2.5V. To ensure low-voltage startup, the step-up employs a low-voltage startup oscillator that activates at 0.9V. The startup oscillator drives the internal N-channel MOSFET at LXSU until OUTSU reaches 2.5V, at which point voltage control is passed to the current-mode PWM circuitry.

Once in regulation, the MAX1565 operates with inputs as low as 0.7V since internal power for the IC is supplied by OUTSU. At low input voltages, the MAX1565 can have difficulty starting into heavy loads.

Soft-Start

The MAX1565 step-down and AUX_ channels feature a soft-start function that limits inrush current and prevents excessive battery loading at startup by ramping the output voltage to the regulation voltage. This is achieved by increasing the internal reference inputs to the controller transconductance amplifiers from 0V to the 1.25V reference voltage over 4096 oscillator cycles (8ms at 500kHz) when initial power is applied or when a channel is enabled. Soft-start is not included in the step-up converter in order to avoid limiting startup capability with loading.

Shutdown

The step-up converter is activated with a high input at ONSU. The step-down and auxiliary DC-to-DC converters 1, 2, and 3 activate with a high input at ONSD, ON1, ON2, and ON3, respectively. The auxiliary controllers and step-down cannot be activated until OUTSU is in regulation. For automatic startup, connect ON_ to OUTSU or a logic level greater than 1.6V.

Design Procedure

Setting the Switching Frequency

Choose a switching frequency to optimize external component size or circuit efficiency for any particular MAX1565 application. Typically, switching frequencies between 300kHz and 600kHz offer a good balance between component size and circuit efficiency. Higher frequencies generally allow smaller components and lower frequencies give better conversion efficiency. The switching frequency is set with an external timing resistor (R_{OSC}) and capacitor (C_{OSC}). At the beginning of a cycle, the timing capacitor charges through the resistor until it reaches V_{REF} . The charge time, t_1 , is:

$$t_1 = -R_{OSC}C_{OSC} \ln [1 - 1.25/V_{OUTSU}]$$

Table 1. Voltage Setting Summary

CHANNEL FB_	FB THRESHOLD (FBSEL_ LOW)	FB THRESHOLD (FBSEL_ HIGH)
FBSU	3.35V	1.25V
FBSD	1.5V	
FB1	5V	
FB2	Always 1.25V	
FB2	(FBSEL is not provided for these channels)	

The capacitor voltage is then given time ($t_2 = 300\text{ns}$) to discharge. The oscillator frequency is

$$f_{OSC} = 1/(t_1 + t_2)$$

f_{OSC} can operate from 100kHz to 1MHz. Choose C_{OSC} between 47pF and 470pF. Determine R_{OSC} from the equation:

$$R_{OSC} = (300\text{ns} - 1/f_{OSC}) / (C_{OSC} \ln [1 - 1.25/V_{OUTSU}])$$

See the *Typical Operating Characteristics* for f_{OSC} versus R_{OSC} using different values of C_{OSC} .

Setting Output Voltages

The MAX1565 step-up/step-down converters and the AUX1 controllers have both factory-set and adjustable output voltages. These are selected by FBSEL_ for the appropriate channel. When FBSEL_ is low, the channel output regulates at its preset voltage. When FBSEL_ is high, the channel regulates FB_ at 1.25V for use with external feedback resistors.

When setting the voltage for auxiliary channels 2 and 3, or when using external feedback at FBSU, FBSD, or FB1, connect a resistive voltage-divider from the output voltage to the corresponding FB_ input. The FB_ input bias current is less than 100nA, so choose the low-side (FB_ to-GND) resistor (R_L), to be 100k Ω or less. Then calculate the high-side (output-to-FB_) resistor (R_H) using:

$$R_H = R_L [(V_{OUT}/1.25) - 1]$$

General Filter Capacitor Selection

The input capacitor in a DC-to-DC converter reduces current peaks drawn from the battery, or other input power source, and reduces switching noise in the controller. The impedance of the input capacitor at the switching frequency should be less than that of the input source so that high-frequency switching currents do not pass through the input source.

Small, High-Efficiency, Five-Channel Digital Still Camera Power Supply

The output capacitor keeps output ripple small and ensures control-loop stability. The output capacitor must also have low impedance at the switching frequency. Ceramic, polymer, and tantalum capacitors are suitable, with ceramic exhibiting the lowest ESR and high-frequency impedance.

Output ripple with a ceramic output capacitor is approximately:

$$V_{\text{RIPPLE}} = I_{\text{L(PEAK)}} [1/(2\pi f_{\text{OSC}} C_{\text{OUT}})]$$

If the capacitor has significant ESR, the output ripple component due to capacitor ESR is:

$$V_{\text{RIPPLE(ESR)}} = I_{\text{L(PEAK)}} \text{ESR}$$

Output capacitor specifics are also discussed in the *Step-Up Compensation* section and the *Step-Down Compensation* section.

Step-Up Component Selection

The external components required for the step-up are an inductor, input and output filter capacitor, and compensation RC. Typically, the inductor is selected to operate with continuous current for best efficiency. An exception might be if the step-up ratio, ($V_{\text{OUT}}/V_{\text{IN}}$), is greater than $1/(1 - D_{\text{MAX}})$, where D_{MAX} is the maximum PWM duty factor of 80%.

When using the step-up channel to boost from a low input voltage, loaded startup is aided by connecting a Schottky diode from the battery to OUTSU . See the Minimum Startup Voltage vs. Load Current graph in the *Typical Operating Characteristics*.

Step-Up Inductor

In most step-up designs, a reasonable inductor value (L_{IDEAL}) can be derived from the following equation, which sets continuous peak-to-peak inductor current at one-half the DC inductor current:

$$L_{\text{IDEAL}} = [2 V_{\text{IN(MAX)}} D(1 - D)] / (I_{\text{OUT}} f_{\text{OSC}})$$

where D is the duty factor given by:

$$D = 1 - (V_{\text{IN}} / V_{\text{OUT}})$$

Given L_{IDEAL} , the consistent peak-to-peak inductor current is $0.5 I_{\text{OUT}}/(1 - D)$. The peak inductor current, $I_{\text{IND(PK)}} = 1.25 I_{\text{OUT}} / (1 - D)$. Inductance values smaller than L_{IDEAL} can be used to reduce inductor size. However, if much smaller values are used, the inductor current rises and a larger output capacitance may be required to suppress output ripple.

Step-Up Compensation

The inductor and output capacitor are usually chosen first in consideration of performance, size, and cost. The compensation resistor and capacitor are then chosen to optimize control-loop stability. In some cases it may help to readjust the inductor or output capacitor value to get optimum results. For typical designs, the component values in the circuit of Figure 1 yield good results.

The step-up converter employs current-mode control, thereby simplifying the control-loop compensation. When the converter operates with continuous inductor current (typically the case), a right-half-plane zero (RHPZ) appears in the loop-gain frequency response. To ensure stability, the control-loop gain should crossover (drop below unity gain) at a frequency (f_{C}) much less than that of the right-half-plane zero.

The relevant characteristics for step-up channel compensation are:

- 1) Transconductance (from FBSU to COMPSU), g_{mEA} (135 μ S)
- 2) Current-sense amplifier transresistance, R_{CS} , (0.3V/A)
- 3) Feedback regulation voltage, V_{FB} (1.25V)
- 4) Step-up output voltage, V_{SUOUT} , in V
- 5) Output load equivalent resistance, R_{LOAD} , in $\Omega = V_{\text{SUOUT}}/I_{\text{LOAD}}$

The key steps for step-up compensation are:

- 1) Place f_{C} sufficiently below the RHPZ and calculate C_{C} .
- 2) Select R_{C} based on the allowed load-step transient. R_{C} sets a voltage delta on the COMP pin that corresponds to load current step.
- 3) Calculate the output filter capacitor (C_{OUT}) required to allow the R_{C} and C_{C} selected.
- 4) Determine if C_{P} is required (if calculated to be > 10pF).

For continuous conduction, the right-plane zero frequency (f_{RHPZ}) is given by:

$$f_{\text{RHPZ}} = V_{\text{OUTSU}} (1 - D)^2 / (2\pi L I_{\text{LOAD}})$$

where D = the duty cycle = $1 - (V_{\text{IN}}/V_{\text{OUT}})$, L is the inductor value, and I_{LOAD} is the maximum output current. Typically target crossover (f_{C}) for 1/6 the RHPZ. For example, if we assume $V_{\text{IN}} = 2\text{V}$, $V_{\text{OUT}} = 3.35\text{V}$, and $I_{\text{OUT}} = 0.5\text{A}$, then $R_{\text{LOAD}} = 6.7\Omega$. If we select $L = 3.3\mu\text{H}$ then:

$$f_{\text{RHPZ}} = 3.35 (2/3.35)^2 / (2\pi \times 4.7 \times 10^{-6} \times 0.5) = 115\text{kHz}$$

Small, High-Efficiency, Five-Channel Digital Still Camera Power Supply

Choose $f_C = 20\text{kHz}$. Calculate C_C :

$$C_C = (V_{FB}/V_{OUT})(R_{LOAD}/R_{CS})(g_m/2\pi f_C)(1 - D) \\ = (1.25/3.35)(6.7/0.3) \times (135\mu\text{S}/(6.28 \times 20\text{kHz})) \\ (2/3.35) = 5.35\text{nF}$$

Choose 6.8nF . Now select R_C such that transient droop requirements are met. For example, if 4% transient droop is allowed, the input to the error amplifier moves $0.04 \times 1.25\text{V}$, or 50mV . The error amp output drives $50\text{mV} \times 135\mu\text{S}$, or $6.75\mu\text{A}$, across R_C to provide transient gain. Since the current-sense transresistance is 0.3V/A , the value of R_C that allows the required load step swing:

$$R_C = 0.3 I_{IND(PK)}/6.75\mu\text{A}$$

In a step-up DC-to-DC converter, if L_{IDEAL} is used, output current relates to inductor current by:

$$I_{IND(PK)} = 1.25 I_{OUT}/(1 - D) = 1.25 I_{OUT} V_{OUT}/V_{IN}$$

Thus, for a 400mA output load step with $V_{IN} = 2\text{V}$ and $V_{OUT} = 3.35\text{V}$:

$$R_C = [1.25(0.3 \times 0.4 \times 3.35)/2]/6.75\mu\text{A} = 37\text{k}\Omega$$

Note that the inductor does not limit the response in this case since it can ramp at $2\text{V}/3.3\mu\text{H}$, or $606\text{mA}/\mu\text{s}$. The output filter capacitor is then chosen so that the C_{OUT} R_{LOAD} pole cancels the $R_C C_C$ zero:

$$C_{OUT} R_{LOAD} = R_C C_C$$

For example:

$$C_{OUT} = 37\text{k}\Omega \times 6.8\text{nF}/6.7 = 37.5\mu\text{F}$$

Since a reasonable value for C_{OUT} is $47\mu\text{F}$ rather than 37.5 , choose $47\mu\text{F}$ and rescale R_C :

$$R_C = 47\mu\text{F} \times 6.7/6.8\text{nF} = 46.3\text{k}\Omega$$

which provides a slightly higher transient gain and consequently less transient droop than previously selected. If the output filter capacitor has significant ESR, a zero occurs at:

$$Z_{ESR} = 1/(2\pi C_{OUT} R_{ESR})$$

If $Z_{ESR} > f_C$, it can be ignored, as is typically the case with ceramic output capacitors. If Z_{ESR} is less than f_C , it should be cancelled with a pole set by capacitor C_P connected from COMPSU to GND:

$$C_P = C_{OUT} R_{ESR}/R_C$$

If C_P is calculated to be $< 10\text{pF}$, it can be omitted.

Step-Down Component Selection

Step-Down Inductor

The external components required for the step-down are an inductor, input and output filter capacitors, and compensation RC network. The MAX1565 step-down converter provides best efficiency with continuous inductor current. A reasonable inductor value (L_{IDEAL}) can be derived from:

$$L_{IDEAL} = 2 (V_{IN}) D (1 - D)/(I_{OUT} f_{OSC})$$

which sets the peak-to-peak inductor current at 1/2 the DC inductor current. D is the duty cycle:

$$D = V_{OUT}/V_{IN}$$

Given L_{IDEAL} , the peak-to-peak inductor current variation is $0.5 I_{OUT}$. The absolute peak inductor current is $1.25 I_{OUT}$. Inductance values smaller than L_{IDEAL} can be used to reduce inductor size. However, if much smaller values are used, inductor current rises and a larger output capacitance may be required to suppress output ripple.

Larger values than L_{IDEAL} can be used to obtain higher output current, but with typically larger inductor size.

Step-Down Compensation

The relevant characteristics for step-down compensation are:

- 1) Transconductance (from FBSD to COMPSD), g_{mEA} ($135\mu\text{S}$)
- 2) Step-down slope compensation pole, $P_{SLOPE} = V_{IN} / (\pi L)$
- 3) Current-sense amplifier transresistance, R_{CS} , (0.6V/A)
- 4) Feedback regulation voltage, V_{FB} (1.25V)
- 5) Step-down output voltage, V_{SD} , in V
- 6) Output load equivalent resistance, R_{LOAD} , in $\Omega = V_{OUTSD}/I_{LOAD}$

The key steps for step-down compensation are:

- 1) Set the compensation RC zero to cancel the $R_{LOAD} C_{OUT}$ pole.
- 2) Set the loop crossover below the lower of 1/5 the slope compensation pole, or 1/5 the switching frequency.

If we assume $V_{IN} = 3.35\text{V}$, $V_{OUT} = 1.5\text{V}$, and $I_{OUT} = 350\text{mA}$, then $R_{LOAD} = 4.3\Omega$.

Small, High-Efficiency, Five-Channel Digital Still Camera Power Supply

If we select $L = 4.7\mu\text{H}$ and $f_{\text{OSC}} = 440\text{kHz}$, $P_{\text{SLOPE}} = V_{\text{IN}}/(\pi L) = 214\text{kHz}$, so choose $f_{\text{C}} = 40\text{kHz}$ and calculate C_{C} :

$$\begin{aligned} C_{\text{C}} &= (V_{\text{FB}}/V_{\text{OUT}})(R_{\text{LOAD}}/R_{\text{CS}})(g_{\text{m}}/2\pi f_{\text{C}}) \\ &= (1.25/1.5)(4.3/0.6) \times (135\mu\text{S}/(6.28 \times 40\text{kHz})) \\ &= 3.2\text{nF} \end{aligned}$$

Choose 3.2nF . Now select R_{C} such that transient droop requirements are met. For example, if 4% transient droop is allowed, the input to the error amplifier moves $0.04 \times 1.25\text{V}$, or 50mV . The error amp output drives $50\text{mV} \times 135\mu\text{S}$, or $6.75\mu\text{A}$ across R_{C} to provide transient gain. Since the current-sense transresistance is 0.6V/A , the value of R_{C} that allows the required load step swing:

$$R_{\text{C}} = 0.6 I_{\text{IND(PK)}}/6.75\mu\text{A}$$

In a step-down DC-to-DC converter, if L_{IDEAL} is used, output current relates to inductor current by:

$$I_{\text{IND(PK)}} = 1.25 I_{\text{OUT}}$$

Thus, for a 250mA output load step with $V_{\text{IN}} = 3.35\text{V}$ and $V_{\text{OUT}} = 1.5\text{V}$:

$$R_{\text{C}} = (1.25 \times 0.6 \times 0.25)/6.75\mu\text{A} = 27.8\text{k}\Omega$$

Choose $27\text{k}\Omega$. Note that the inductor does not limit the response in this case since it can ramp at $(V_{\text{IN}} - V_{\text{OUT}})/4.7\mu\text{H}$, or $(3.35 - 1.5)/4.7\mu\text{H} = 394\text{mA}/\mu\text{s}$.

The output filter capacitor is then chosen so that the $C_{\text{OUT}} R_{\text{LOAD}}$ pole cancels the $R_{\text{C}} C_{\text{C}}$ zero:

$$C_{\text{OUT}R_{\text{LOAD}}} = R_{\text{C}} C_{\text{C}}$$

For example:

$$C_{\text{OUT}} = 27\text{k}\Omega \times 3.2\text{nF}/4.3 = 20.7\mu\text{F}$$

Choose $22\mu\text{F}$. If the output filter capacitor has significant ESR, a zero occurs at:

$$Z_{\text{ESR}} = 1/(2\pi C_{\text{OUT}}R_{\text{ESR}})$$

If $Z_{\text{ESR}} > f_{\text{C}}$, it can be ignored, as is typically the case with ceramic output capacitors. If Z_{ESR} is less than f_{C} , it should be cancelled with a pole set by capacitor C_{P} connected from COMP to GND:

$$C_{\text{P}} = C_{\text{OUT}}R_{\text{ESR}}/R_{\text{C}}$$

If C_{P} is calculated to be $< 10\text{pF}$, it can be omitted.

Auxiliary Controller Component Selection

External MOSFET

All MAX1565 auxiliary controllers drive external logic-level N-channel MOSFETs. Significant MOSFET selection parameters are:

- 1) On-resistance ($R_{\text{DS(ON)}}$)
- 2) Maximum drain-to-source voltage ($V_{\text{DS(MAX)}}$)
- 3) Total gate charge (Q_{G})
- 4) Reverse transfer capacitance (C_{RSS})

$DL_{\text{-}}$ swings between OUTSU and GND. Use a MOSFET with on-resistance specified at or below the main output voltage. The gate charge, Q_{G} , includes all capacitance associated with charging the gate and helps to predict MOSFET transition time between on and off states. MOSFET power dissipation is a combination of on-resistance and transition losses. The on-resistance loss is:

$$P_{\text{RDS(ON)}} = D I_{\text{L}}^2 R_{\text{DS(ON)}}$$

where D is the duty cycle, I_{L} is the average inductor current, and $R_{\text{DS(ON)}}$ is MOSFET on-resistance. The transition loss is approximately:

$$P_{\text{TRANS}} = (V_{\text{OUT}} I_{\text{L}} f_{\text{OSC}} t_{\text{T}})/3$$

where V_{OUT} is the output voltage, I_{L} is the average inductor current, f_{OSC} is the switching frequency, and t_{T} is the transition time. The transition time is approximately $Q_{\text{G}}/I_{\text{G}}$, where Q_{G} is the total gate charge, and I_{G} is the gate drive current (typically 0.5A). The total power dissipation in the MOSFET is:

$$P_{\text{MOSFET}} = P_{\text{RDS(ON)}} + P_{\text{TRANS}}$$

Diode

For most auxiliary applications, a Schottky diode rectifies the output voltage. The Schottky diode's low forward voltage and fast recovery time provide the best performance in most applications. Silicon signal diodes (such as 1N4148) are sometimes adequate in low-current ($< 10\text{mA}$) high-voltage ($> 10\text{V}$) output circuits where the output voltage is large compared to the diode forward voltage.

Auxiliary Compensation

The auxiliary controllers employ voltage-mode control to regulate their output voltage. Optimum compensation somewhat depends on whether the design uses continuous or discontinuous inductor current.

Small, High-Efficiency, Five-Channel Digital Still Camera Power Supply

Discontinuous Inductor Current

When the inductor current falls to zero on each switching cycle, it is described as discontinuous. The inductor is not utilized as efficiently as with continuous current. This often has little negative impact in light-load applications since the coil losses may already be low compared to other losses. A benefit of discontinuous inductor current is more flexible loop compensation and no maximum duty-cycle restriction on boost ratio.

To ensure discontinuous operation, the inductor must have a sufficiently low inductance to fully discharge on each cycle. This occurs when:

$$L < [V_{IN}^2 (V_{OUT} - V_{IN}) / V_{OUT}^3] [R_{LOAD} / (2 f_{OSC})]$$

A discontinuous current boost has a single pole at:

$$f_p = (2V_{OUT} - V_{IN}) / (2\pi R_{LOAD} C_{OUT} V_{OUT})$$

Choose the integrator capacitor such that the unity-gain crossover (f_c) occurs at $f_{OSC}/10$ or lower. Note that for many auxiliary circuits, such as those powering motors, LEDs, or other loads that do not require fast transient response, it is often acceptable to overcompensate by setting f_c at $f_{OSC}/20$ or lower. C_C is then determined by:

$$C_C = [2V_{OUT} V_{IN} / ((2V_{OUT} - V_{IN}) V_{RAMP})] [V_{OUT} / (K(V_{OUT} - V_{IN}))]^{1/2} [(V_{FB} / V_{OUT}) (g_m / (2\pi f_c))]$$

where $K = 2 L f_{OSC} / R_{LOAD}$, and V_{RAMP} is the internal slope compensation voltage ramp of 1.25V. The $C_C R_C$ zero is then used to cancel the f_p pole, so:

$$R_C = R_{LOAD} C_{OUT} V_{OUT} / [(2V_{OUT} - V_{IN}) C_C]$$

Continuous Inductor Current

Continuous inductor current can sometimes improve boost efficiency by lowering the ratio between peak inductor current and output current. It does this at the expense of a larger inductance value that requires larger size for a given current rating. With continuous inductor current boost operation, there is a right-plane zero at:

$$f_{RHPZ} = (1 - D)^2 R_{LOAD} / (2\pi L)$$

where $(1 - D) = V_{IN} / V_{OUT}$ (in a boost converter). A complex pole pair is located at:

$$f_0 = V_{OUT} / [2\pi V_{IN} (L C_{OUT})^{1/2}]$$

If the zero due to the output capacitor capacitance and ESR is less than 1/10 the right-plane zero:

$$Z_{COUT} = 1 / (2\pi C_{OUT} R_{ESR}) < f_{RHPZ} / 10$$

Choose C_C such that the crossover frequency f_c occurs at Z_{COUT} . The ESR zero provides a phase boost at crossover.

$$C_C = (V_{IN} / V_{RAMP}) (V_{FB} / V_{OUT}) (g_m / (2\pi Z_{COUT}))$$

Choose R_C to place the integrator zero, $1 / (2\pi R_C C_C)$, at f_0 to cancel one of the pole pairs:

$$R_C = V_{IN} (L C_{OUT})^{1/2} / (V_{OUT} C_C)$$

If Z_{COUT} is not less than $f_{RHPZ}/10$ (as is typical with ceramic output capacitors) and continuous conduction is required, then cross the loop over before f_{RHPZ} and f_0 :

$$f_c < f_0 / 10, \text{ and } f_c < f_{RHPZ} / 10$$

In that case:

$$C_C = (V_{IN} / V_{RAMP}) (V_{FB} / V_{OUT}) (g_m / (2\pi f_c))$$

Place $1 / (2\pi R_C C_C) = 1 / (2\pi R_{LOAD} C_{OUT})$, so that $R_C = R_{LOAD} C_{OUT} / C_C$ or reduce the inductor value for discontinuous operation.

Applications Information

LED, LCD, and Other Boost Applications

Any auxiliary channel can be used for a wide variety of step-up applications. These include generating 5V or some other voltage for motor or actuator drive, generating 15V or a similar voltage for LCD bias, or generating a step-up current source to efficiently drive a series array of white LEDs for display backlighting. Figures 5 and 6 show examples of these applications.

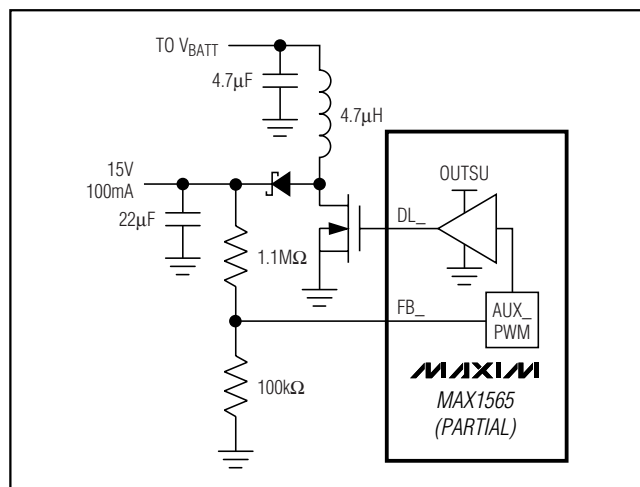

Figure 5. Using an AUX_ Controller Channel to Generate LCD Bias

Small, High-Efficiency, Five-Channel Digital Still Camera Power Supply

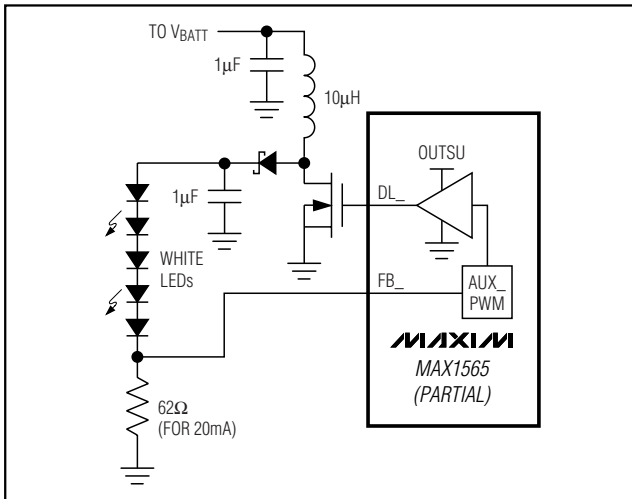

Figure 6. AUX_ Channel Powering a White LED Step-Up Current Source

SEPIC Buck-Boost

The MAX1565's internal switch step-up and step-down can be cascaded to make a high-efficiency buck-boost converter, but it may sometimes be desirable to build a second buck-boost converter with an AUX_ controller. One type of step-up/step-down converter is the SEPIC (Figure 7). Inductors L1 and L2 can be separate inductors or wound on a single core and coupled like a transformer. Typically, a coupled inductor improves efficiency since some power is transferred through the coupling, causing less power to pass through the coupling capacitor (C2). Likewise, C2 should have low ESR to improve efficiency. The ripple current rating must be greater than the larger of the input and output currents. The MOSFET (Q1) drain-to-source voltage rating, and the rectifier (D1) reverse-voltage rating must exceed the sum of the input and output voltages. Other types of step-up/step-down circuits are a flyback converter and a step-up converter followed by a linear regulator.

Multiple Output Flyback Circuits

Some applications require multiple voltages from a single converter channel. This is often the case when generating voltages for CCD bias or LCD power. Figure 8 shows a two-output flyback configuration with AUX_. The controller drives an external MOSFET that switches the transformer primary. Two transformer secondaries generate the output voltages. Only one positive output voltage can be fed back, so the other voltages are set by the turns ratio of the transformer secondaries. The load stability of the other secondary voltages depends on transformer leakage inductance and winding resistance. Voltage regulation is best when the load on the

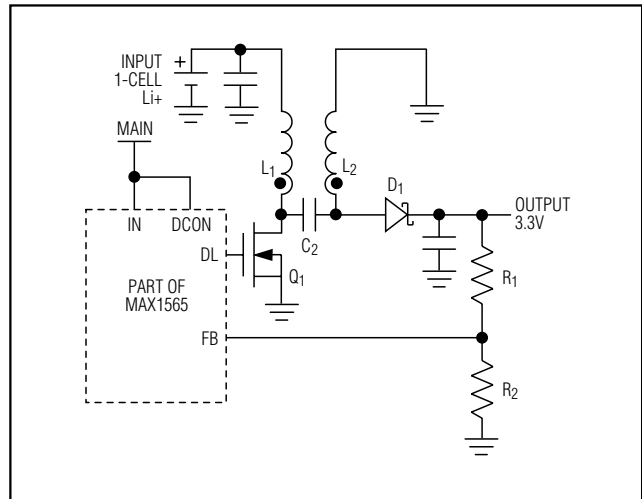

Figure 7. Auxiliary SEPIC Configuration

secondary that is not fed back is small when compared to the load on the one that is. Regulation also improves if the load current range is limited. Consult the transformer manufacturer for the proper design for a given application.

Boost with Charge Pump for Positive and Negative Outputs

Negative output voltages can be produced without a transformer, using a charge-pump circuit with an auxiliary controller as shown in Figure 9. When MOSFET Q1 turns off, the voltage at its drain rises to supply current to V_{OUT+}. At the same time, C1 charges to the voltage V_{OUT+} through D1.

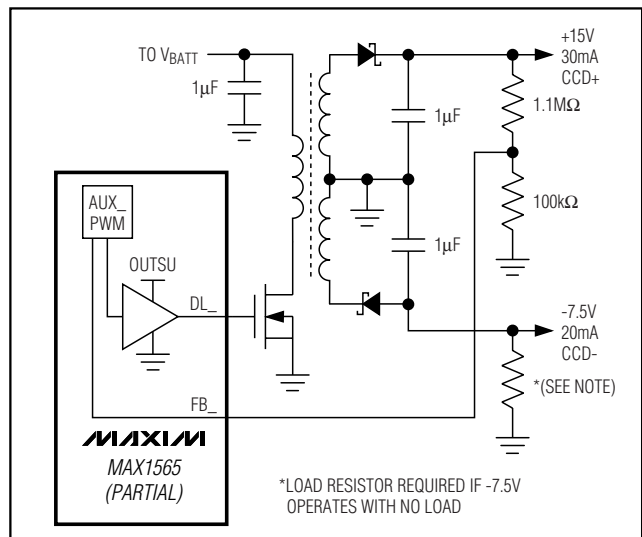

Figure 8. +15V and -7.5V CCD Bias with Transformer

Small, High-Efficiency, Five-Channel Digital Still Camera Power Supply

MAX1565

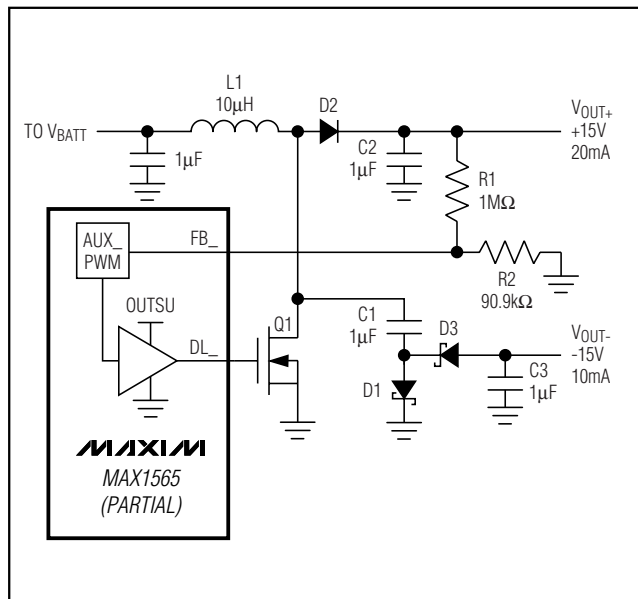

Figure 9. ±15V Output Using a Boost with Charge-Pump Inversion

When the MOSFET turns on, C1 discharges through D3, thereby charging C3 to V_{OUT-} minus the drop across D3 to create roughly the same voltage as V_{OUT+} at V_{OUT-} but with inverted polarity.

If different magnitudes are required for the positive and negative voltages, a linear regulator can be used at one of the outputs to achieve the desired voltages. One such connection is shown in Figure 10. This circuit is somewhat unique in that a positive output linear regulator is able to regulate the negative output. It does this by controlling the charge to the flying capacitor rather than directly regulating at the output.

Adding a MAX1801 Slave

The MAX1801 is a 6-pin SOT slave DC-to-DC controller that can be connected to generate additional output voltages. It does not generate its own reference or oscillator. Instead, it uses the reference and oscillator of the MAX1565 (Figure 11). The MAX1801 controller operation and design are similar to that of a MAX1565 AUX controller. All comments in the *Auxiliary Controller Component Selection* section also apply to add-on MAX1801 slave controllers. For more details, refer to the MAX1801 data sheet.

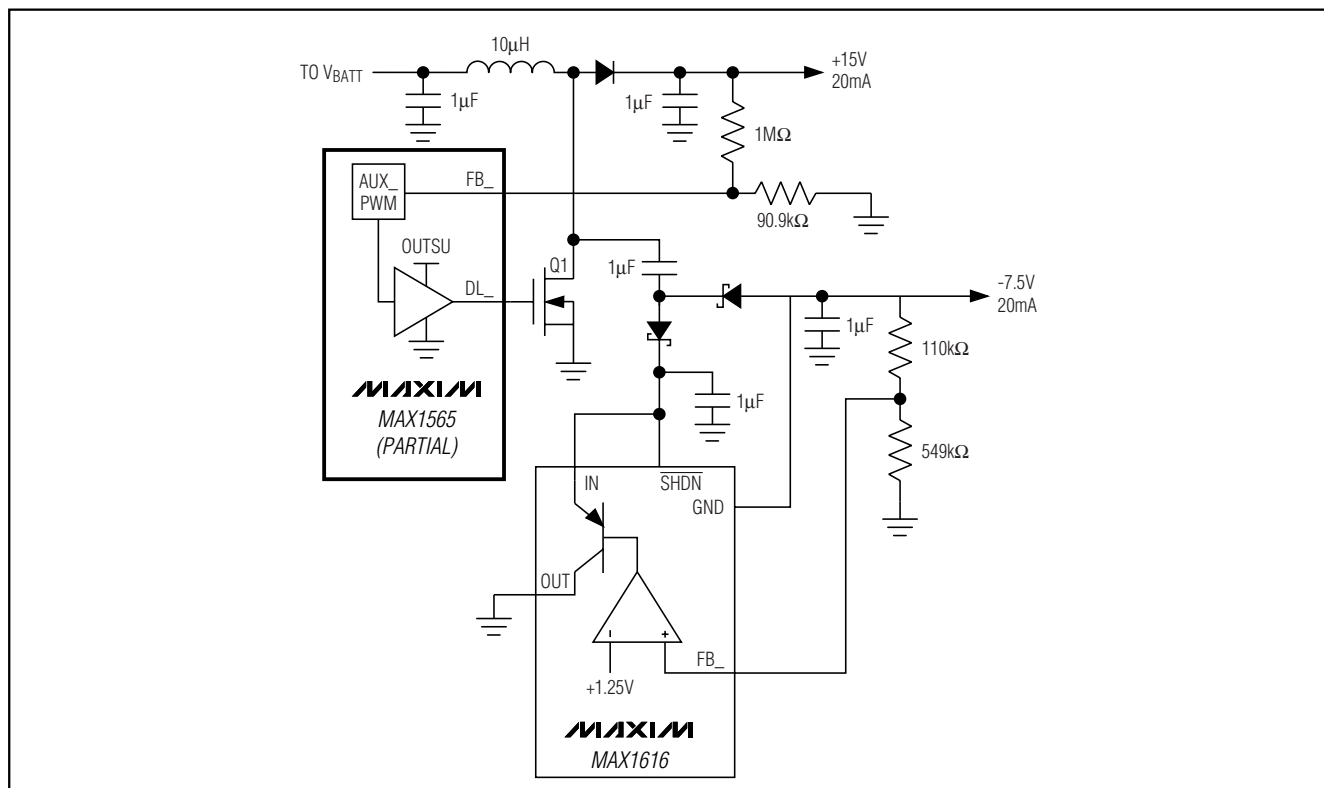

Figure 10. +15V and -7.5V CCD Bias without Transformer

Small, High-Efficiency, Five-Channel Digital Still Camera Power Supply

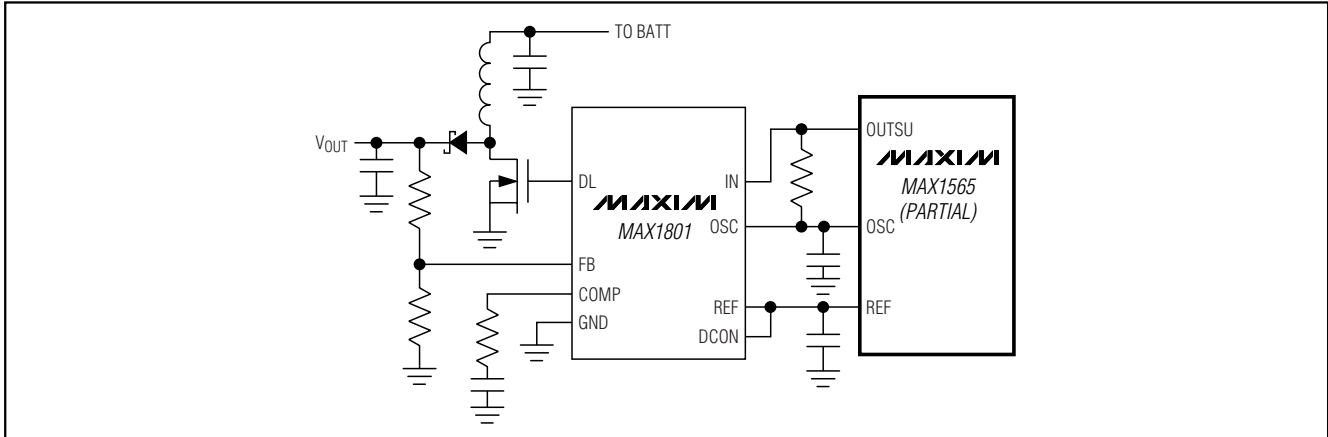

Figure 11. Connecting the MAX1801 Slave PWM Controller to the MAX1565

Using SDOK for Power Sequencing

SDOK goes low when the step-down reaches regulation. Some microcontrollers with low-voltage cores require that the high-voltage (3.3V) I/O rail not be powered up until the core has a valid supply. The circuit in Figure 12 accomplishes this by driving the gate of a PFET connected between the 3.3V output and the microcontroller I/O supply. Alternately, power sequencing may be implemented by connecting RC networks to the appropriate converter ON_ inputs.

Setting OUTSD Below 1.25V

The step-down feedback voltage is 1.25V when FBSELSD is high. With a standard two-resistor feedback network, the output voltage may be set to values between 1.25V and the input voltage. If a step-down output voltage less than 1.25V is desired, it can be set by adding a third feedback resistor from FB to a voltage higher than 1.25V (the step-up output is a convenient voltage for this) as shown in Figure 13.

The equation governing output voltage shown in Figure 13 is:

$$0 = [(V_{SD} - V_{FBSD})/R1] + [(0 - V_{FBSD})/R2] + [(V_{SU} - V_{FBSD})/R3]$$

where V_{SD} is the output voltage, V_{FBSD} is 1.25V, and V_{SU} is the step-up output voltage. Note that any available voltage that is higher than 1.25V can be used as the connection point for R3 in Figure 13 and for the V_{SD} term in the equation. Since there are multiple solutions for R1, R2, and R3, the above equation cannot be written in terms of one resistor. The best method for determining resistor values is to enter the above equation into a spreadsheet and test estimated resistors' values. A good starting point is with 100k Ω at R2 and R3.

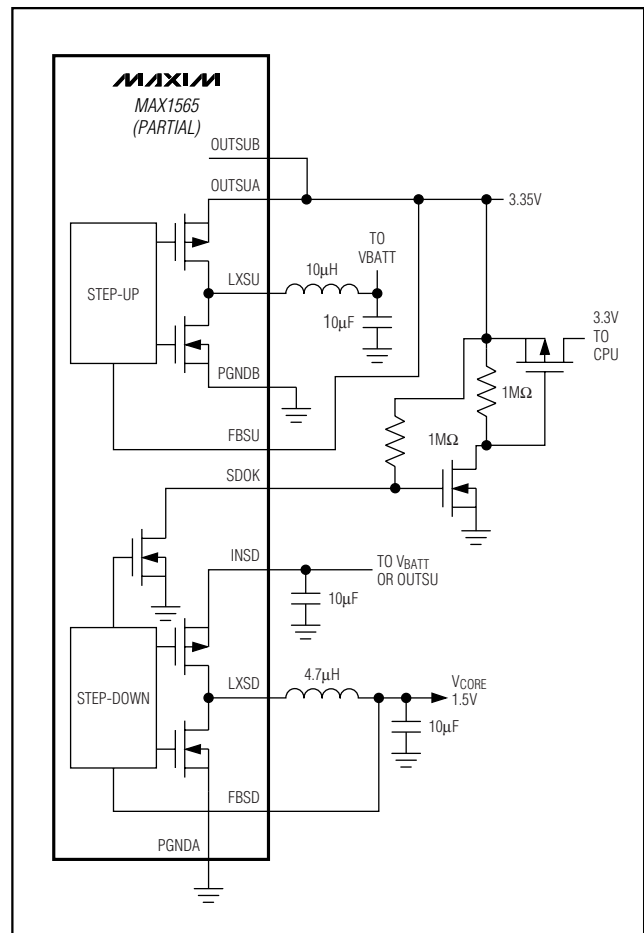

Figure 12. Using SDOK to Gate 3.3V Power to CPU After the Core Voltage is OK

Small, High-Efficiency, Five-Channel Digital Still Camera Power Supply

Designing a PC Board

Good PC board layout is important to achieve optimal performance from the MAX1565. Poor design can cause excessive conducted and/or radiated noise. Conductors carrying discontinuous currents, and any high-current path should be made as short and wide as possible. A separate low-noise ground plane containing the reference and signal grounds should connect to the power-ground plane at only one point to minimize the effects of power-ground currents. Typically, the ground planes are best joined right at the IC.

Keep the voltage feedback network very close to the IC, preferably within 0.2in (5mm) of the FB_ pin. Nodes with high dV/dt (switching nodes) should be kept as small as possible and should be routed away from high-impedance nodes such as FB_. Refer to the MAX1565EVKIT evaluation kit data sheet for a full PC board example.

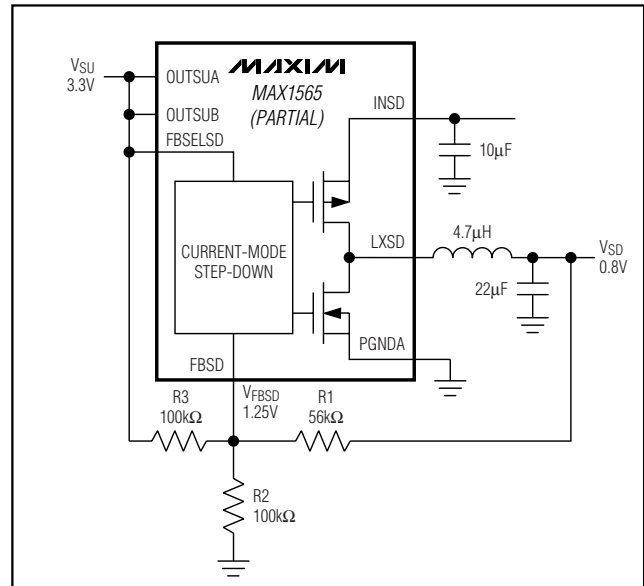

Figure 13. Setting OUTSD for Outputs Below 1.25V

Chip Information

TRANSISTOR COUNT: 9420

PROCESS: BiCMOS

MAX1565

Small, High-Efficiency, Five-Channel Digital Still Camera Power Supply

Package Information

(The package drawing(s) in this data sheet may not reflect the most current specifications. For the latest package outline information, go to www.maxim-ic.com/packages.)

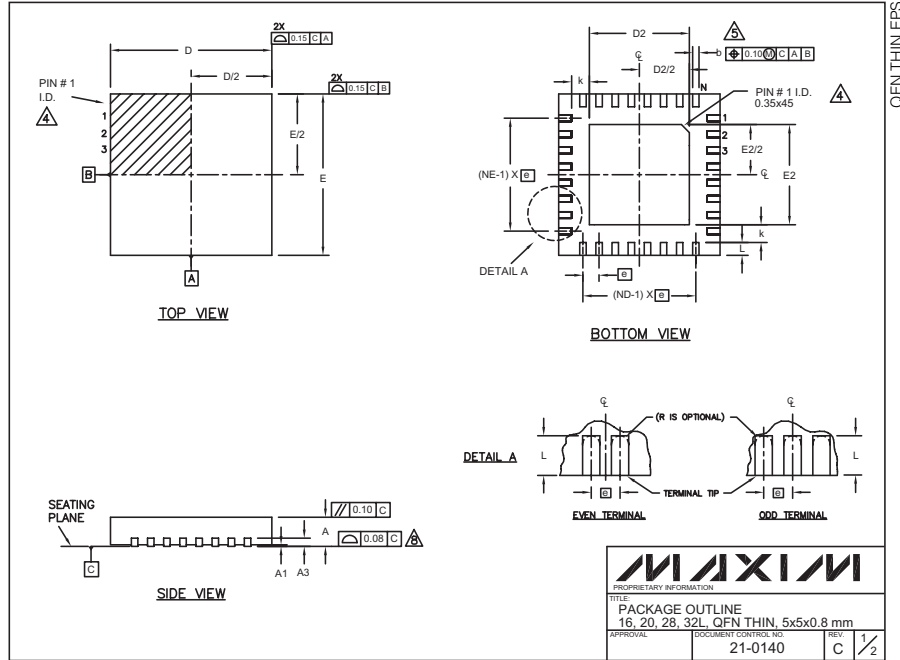

COMMON DIMENSIONS												
PKG. SYMBOL	16L 5x5			20L 5x5			28L 5x5			32L 5x5		
	MIN.	NOM.	MAX.	MIN.	NOM.	MAX.	MIN.	NOM.	MAX.	MIN.	NOM.	MAX.
A	0.70	0.75	0.80	0.70	0.75	0.80	0.70	0.75	0.80	0.70	0.75	0.80
A1	0	0.02	0.05	0	0.02	0.05	0	0.02	0.05	0	0.02	0.05
A3	0.20 REF.			0.20 REF.			0.20 REF.			0.20 REF.		
b	0.25	0.30	0.35	0.25	0.30	0.35	0.20	0.25	0.30	0.20	0.25	0.30
D	4.90	5.00	5.10	4.90	5.00	5.10	4.90	5.00	5.10	4.90	5.00	5.10
E	4.90	5.00	5.10	4.90	5.00	5.10	4.90	5.00	5.10	4.90	5.00	5.10
e	0.80 BSC.			0.65 BSC.			0.50 BSC.			0.50 BSC.		
k	0.25	-	-	0.25	-	-	0.25	-	-	0.25	-	-
L	0.45	0.55	0.65	0.45	0.55	0.65	0.45	0.55	0.65	0.30	0.40	0.50
N	16			20			28			32		
ND	4			5			7			8		
NE	4			5			7			8		
JEDEC	WHHB			WHHC			WHHD-1			WHHD-2		

EXPOSED PAD VARIATIONS									
PKG. CODES	D2			E2					
	MIN.	NOM.	MAX.	MIN.	NOM.	MAX.			
T1655-1	3.00	3.10	3.20	3.00	3.10	3.20			
T2055-2	3.00	3.10	3.20	3.00	3.10	3.20			
T2855-1	3.15	3.25	3.35	3.15	3.25	3.35			
T2855-2	2.60	2.70	2.80	2.60	2.70	2.80			
T3255-2	3.00	3.10	3.20	3.00	3.10	3.20			

NOTES:

- DIMENSIONING & TOLERANCING CONFORM TO ASME Y14.5M-1994.
- ALL DIMENSIONS ARE IN MILLIMETERS. ANGLES ARE IN DEGREES.
- N IS THE TOTAL NUMBER OF TERMINALS.
- THE TERMINAL #1 IDENTIFIER AND TERMINAL NUMBERING CONVENTION SHALL CONFORM TO JESD 95-1 SPP-012. DETAILS OF TERMINAL #1 IDENTIFIER ARE OPTIONAL, BUT MUST BE LOCATED WITHIN THE ZONE INDICATED. THE TERMINAL #1 IDENTIFIER MAY BE EITHER A MOLD OR MARKED FEATURE.
- DIMENSION b APPLIES TO METALLIZED TERMINAL AND IS MEASURED BETWEEN 0.25 mm AND 0.30 mm FROM TERMINAL TIP.
- ND AND NE REFER TO THE NUMBER OF TERMINALS ON EACH D AND E SIDE RESPECTIVELY.
- DEPOPULATION IS POSSIBLE IN A SYMMETRICAL FASHION.
- COPLANARITY APPLIES TO THE EXPOSED HEAT SINK SLUG AS WELL AS THE TERMINALS.
- DRAWING CONFORMS TO JEDEC MO220.
- WARPAGE SHALL NOT EXCEED 0.10 mm.

MAXIM

PROPRIETARY INFORMATION

TITLE: PACKAGE OUTLINE
16, 20, 28, 32L, QFN THIN, 5x5x0.8 mm

APPROVAL: _____ DOCUMENT CONTROL NO: 21-0140 REV: C 2/2

Maxim cannot assume responsibility for use of any circuitry other than circuitry entirely embodied in a Maxim product. No circuit patent licenses are implied. Maxim reserves the right to change the circuitry and specifications without notice at any time.

26 **Maxim Integrated Products, 120 San Gabriel Drive, Sunnyvale, CA 94086 408-737-7600**