

Distributed by:

**JAMECO**<sup>®</sup>  
ELECTRONICS

**www.Jameco.com ♦ 1-800-831-4242**

The content and copyrights of the attached  
material are the property of its owner.

Jameco Part Number 1225594



# Precision, Single-Supply, SPST Analog Switches

MAX323/MAX324/MAX325

## General Description

The MAX323/MAX324/MAX325 are precision, dual, SPST analog switches. They are single-supply devices designed to operate from +2.7V to +16V. The MAX323 has two normally open (NO) switches, and the MAX324 has two normally closed (NC) switches. The MAX325 has one NO and one NC switch. Low power consumption (5µW) makes these parts ideal for battery-powered equipment. These switches offer low leakage currents (100pA max) and fast switching speeds (t<sub>ON</sub> = 150ns max, t<sub>OFF</sub> = 100ns max).

When powered from a 5V supply, the MAX323 series offers 2Ω max matching between channels, 60Ω max on-resistance, and 6Ω max R<sub>ON</sub> flatness.

These switches also offer 5pC max charge injection, and a minimum of 2000V ESD per Method 3015.7.

For equivalent devices specified for dual-supply operation, see the MAX320/MAX321/MAX322 data sheet. For quad versions of the MAX320 series, see MAX391/MAX392/MAX393 data sheet.

## Applications

- |                           |                              |
|---------------------------|------------------------------|
| Battery-Operated Systems  | Sample-and-Hold Circuits     |
| Heads-Up Displays         | Guidance and Control Systems |
| Audio and Video Switching | Military Radios              |
| Test Equipment            | Communications Systems       |
| +3V, +5V DACs and ADCs    | PBX, PABX                    |

## Features

- ◆ Low On-Resistance (R<sub>ON</sub>), 60Ω max (33Ω typ)
- ◆ R<sub>ON</sub> Matching Between Channels <2Ω
- ◆ R<sub>ON</sub> Flatness <6Ω Max
- ◆ Guaranteed Charge Injection <5pC
- ◆ Single-Supply Operation (+2.7V to +16V)
- ◆ Low Power Consumption, <5µW
- ◆ Low Leakage Current Over Temperature, <2.5nA at +85°C
- ◆ Fast Switching: t<sub>ON</sub> <150ns, t<sub>OFF</sub> <100ns
- ◆ Guaranteed Break-Before-Make (MAX325 only)
- ◆ TTL/CMOS Logic Compatible

## Ordering Information

| PART      | TEMP. RANGE     | PIN-PACKAGE   |
|-----------|-----------------|---------------|
| MAX323CPA | 0°C to +70°C    | 8 Plastic DIP |
| MAX323CUA | 0°C to +70°C    | 8 µMAX        |
| MAX323CSA | 0°C to +70°C    | 8 SO          |
| MAX323C/D | 0°C to +70°C    | Dice*         |
| MAX323EPA | -40°C to +85°C  | 8 Plastic DIP |
| MAX323ESA | -40°C to +85°C  | 8 SO          |
| MAX323EJA | -40°C to +85°C  | 8 CERDIP**    |
| MAX323MJA | -55°C to +125°C | 8 CERDIP**    |

Ordering Information continued at end of data sheet.

\* Contact factory for dice specifications.

\*\* Contact factory for availability.

## Pin Configurations/Functional Diagrams/Truth Tables

TOP VIEW

**MAX323**  
DIP/SO/µMAX

| MAX323 |        |
|--------|--------|
| LOGIC  | SWITCH |
| 0      | OFF    |
| 1      | ON     |

**MAX324**  
DIP/SO/µMAX

| MAX324 |        |
|--------|--------|
| LOGIC  | SWITCH |
| 0      | ON     |
| 1      | OFF    |

**MAX325**  
DIP/SO/µMAX

| MAX325 |          |          |
|--------|----------|----------|
| LOGIC  | SWITCH 1 | SWITCH 2 |
| 0      | OFF      | ON       |
| 1      | ON       | OFF      |

SWITCHES SHOWN FOR LOGIC "0" INPUT



# Precision, Single-Supply, SPST Analog Switches

## ABSOLUTE MAXIMUM RATINGS

|  |                      |  |
|--|----------------------|--|
| Voltage Referenced to GND  |                      | CERDIP (derate 8.00mW/°C above +70°C) .....640mW |
| V+ .....   | -0.3V to +17V        | μMAX (derate 4.10mW/°C above +70°C) .....330mW   |
| IN_, COM_, NC_, NO_ (Note 1) .....                                     | -0.3V to (V+ + 0.3V) | Operating Temperature Ranges                     |
| Continuous Current (any terminal) .....                                | 30mA                 | MAX32_C_ _ .....0°C to +70°C                     |
| Peak Current, COM_, NO_, NC_ (pulsed at 1ms, 10% duty cycle max) ..... | 100mA                | MAX32_E_ _ .....-40°C to +85°C                   |
| ESD per Method 3015.7 .....  | >2000V               | MAX32_MJA .....-55°C to +125°C                   |
| Continuous Power Dissipation   |                      | Storage Temperature Range .....-65°C to +150°C   |
| Plastic DIP (derate 9.09mW/°C above +70°C) .....                       | 727mW                | Lead Temperature (soldering, 10sec) .....+300°C  |
| Narrow SO (derate 5.88mW/°C above +70°C) .....                         | 471mW                |  |

**Note 1:** Signals on NC, NO, COM, or IN exceeding V+ or V- are clamped by internal diodes. Limit forward diode current to maximum current rating.

Stresses beyond those listed under "Absolute Maximum Ratings" may cause permanent damage to the device. These are stress ratings only, and functional operation of the device at these or any other conditions beyond those indicated in the operational sections of the specifications is not implied. Exposure to absolute maximum rating conditions for extended periods may affect device reliability.

## ELECTRICAL CHARACTERISTICS—Single +5V Supply

(V+ = 5V ±10%, GND = 0V, VINH = 2.4V, VINL = 0.8V, TA = TMIN to TMAX, unless otherwise noted.)

| PARAMETER                                     | SYMBOL               | CONDITIONS                                     |                   | MIN  | TYP<br>(Note 2) | MAX | UNITS |
|---|----------------------|--|-------------------|------|-----------------|-----|-------|
| <b>ANALOG SWITCH</b>                          |                      |  |                   |      |                 |     |       |
| Analog Signal Range                           | VCOM, VNO, VNC       | (Note 3)                                       |                   | 0    |                 | V+  | V     |
| On-Resistance                                 | RON                  | V+ = 4.5V, ICOM = 1.0mA, VNO or VNC = 3.5V     | TA = +25°C        | 33   | 60              |     | Ω     |
|   |                      |  | TA = TMIN to TMAX |      |                 | 75  |       |
| On-Resistance Match Between Channels (Note 4) | ΔRON                 | V+ = 5V, ICOM = 1.0mA, VNO or VNC = 3V         | TA = +25°C        | 0.8  | 2               |     | Ω     |
|   |                      |  | TA = TMIN to TMAX |      |                 | 4   |       |
| On-Resistance Flatness (Notes 3, 5)           | RFLAT(ON)            | V+ = 5V, ICOM = 1.0mA, VNO or VNC = 1V, 2V, 3V | TA = +25°C        | 2    | 6               |     | Ω     |
|   |                      |  | TA = TMIN to TMAX |      |                 | 8   |       |
| NO or NC Off Leakage Current (Note 6)         | INO(OFF) or INC(OFF) | V+ = 5.5V, VCOM = 1V, VNO or VNC = 4.5V        | TA = +25°C        | -0.1 | 0.01            | 0.1 | nA    |
|   |                      |  | TA = TMIN to TMAX | C, E | -5              | 5   |       |
|   |                      |  |                   | M    | -40             | 40  |       |
| COM Off Leakage Current (Note 6)              | ICOM(OFF)            | V+ = 5.5V, VCOM = 4.5V, VNO or VNC = 1V        | TA = +25°C        | -0.1 |                 | 0.1 | nA    |
|   |                      |  | TA = TMIN to TMAX | C, E | -5              | 5   |       |
|   |                      |  |                   | M    | -40             | 40  |       |
| COM On Leakage Current (Note 6)               | ICOM(ON)             | V+ = 5.5V, VCOM = 5V, or VNO or VNC = 5V       | TA = +25°C        | -0.2 |                 | 0.2 | nA    |
|   |                      |  | TA = TMIN to TMAX | C, E | -10             | 10  |       |
|   |                      |  |                   | M    | -50             | 50  |       |

# Precision, Single-Supply, SPST Analog Switches

MAX323/MAX324/MAX325

## ELECTRICAL CHARACTERISTICS—Single +5V Supply (continued)

(V+ = 5V ±10%, GND = 0V, VINH = 2.4V, VINL = 0.8V, TA = TMIN to TMAX, unless otherwise noted.)

| PARAMETER                             | SYMBOL    | CONDITIONS  | MIN               | TYP<br>(Note 2) | MAX | UNITS |
|---------------------------------------|-----------|---|-------------------|-----------------|-----|-------|
| <b>DYNAMIC</b>                        |           |   |                   |                 |     |       |
| Turn-On Time                          | tON       | VNO or VNC = 3V                                   | TA = +25°C        | 85              | 150 | ns    |
|                                       |           |   | TA = TMIN to TMAX |                 | 240 |       |
| Turn-Off Time                         | tOFF      | VNO or VNC = 3V                                   | TA = +25°C        | 25              | 100 | ns    |
|                                       |           |   | TA = TMIN to TMAX |                 | 150 |       |
| Break-Before-Make Time Delay (Note 3) | tD        | MAX325 only, RL = 300Ω, CL = 35pF                 | 2                 |                 |     | ns    |
| Charge Injection (Note 3)             | Q         | CL = 1.0nF, VGEN = 0V, RGEN = 0V, Figure 4        | TA = +25°C        | 1               | 5   | pC    |
| Off Isolation (Note 7)                | OIRR      | RL = 50Ω, CL = 5pF, f = 1MHz, Figure 5            | TA = +25°C        | 72              |     | dB    |
| Crosstalk (Note 8)                    |           | RL = 50Ω, CL = 5pF, f = 1MHz, Figure 6            | TA = +25°C        | 85              |     | dB    |
| NC or NO Capacitance                  | COFF      | f = 1MHz, Figure 7                                | TA = +25°C        | 9               |     | pF    |
| COM Off Capacitance                   | CCOM(OFF) | f = 1MHz, Figure 7                                | TA = +25°C        | 9               |     | pF    |
| COM On Capacitance                    | CCOM(ON)  | f = 1MHz, Figure 8                                | TA = +25°C        | 22              |     | pF    |
| <b>SUPPLY</b>                         |           |   |                   |                 |     |       |
| Power-Supply Range                    |           |   | 2.7               |                 | 16  | V     |
| Positive Supply Current               | I+        | V+ = 5.5V, VIN = 0V or V+, all channels on or off | -1                | 0.0001          | 1   | μA    |
| <b>LOGIC INPUT</b>                    |           |   |                   |                 |     |       |
| Input Voltage Low                     | VINL      |   |                   |                 | 0.8 | V     |
| Input Voltage High                    | VINH      |   | 2.4               |                 |     | V     |

# Precision, Single-Supply, SPST Analog Switches

## ELECTRICAL CHARACTERISTICS—Single +3.3V Supply

( $V_+ = 3.0V$  to  $3.6V$ ,  $GND = 0V$ ,  $V_{INH} = 2.4V$ ,  $V_{INL} = 0.6V$ ,  $T_A = T_{MIN}$  to  $T_{MAX}$ , unless otherwise noted.)

| PARAMETER                             | SYMBOL                                | CONDITIONS   |                              | MIN | TYP<br>(Note 2) | MAX   | UNITS    |
|---------------------------------------|---------------------------------------|--|------------------------------|-----|-----------------|-------|----------|
| <b>ANALOG SWITCH</b>                  |                                       |  |                              |     |                 |       |          |
| Analog Signal Range                   | $V_{COM}$ ,<br>$V_{NO}$ ,<br>$V_{NC}$ | (Note 3)   |                              | 0   |                 | $V_+$ | V        |
| Channel On-Resistance                 | $R_{ON}$                              | $V_+ = 3V$ ,<br>$I_{COM} = 1.0mA$ ,<br>$V_{NO}$ or $V_{NC} = 1.5V$ | $T_A = +25^\circ C$          | 83  | 175             |       | $\Omega$ |
|                                       |                                       |  | $T_A = T_{MIN}$ to $T_{MAX}$ |     | 275             |       |          |
| <b>DYNAMIC</b>                        |                                       |  |                              |     |                 |       |          |
| Turn-On Time (Note 3)                 | $t_{ON}$                              | $V_{NO}$ or $V_{NC} = 1.5V$  | $T_A = +25^\circ C$          | 160 | 400             |       | ns       |
|                                       |                                       |  | $T_A = T_{MIN}$ to $T_{MAX}$ |     | 500             |       |          |
| Turn-Off Time (Note 3)                | $t_{OFF}$                             | $V_{NO}$ or $V_{NC} = 1.5V$  | $T_A = +25^\circ C$          | 40  | 125             |       | ns       |
|                                       |                                       |  | $T_A = T_{MIN}$ to $T_{MAX}$ |     | 175             |       |          |
| Break-Before-Make Time Delay (Note 3) | $t_D$                                 | MAX325 only,<br>$R_L = 300\Omega$ , $C_L = 35pF$                   | $T_A = +25^\circ C$          | 2   | 5               |       | ns       |
| Charge Injection (Note 3)             | $Q$                                   | $C_L = 1.0nF$ ,<br>$V_{GEN} = 0V$ , $R_{GEN} = 0V$                 | $T_A = +25^\circ C$          |     | 1               | 5     | pC       |
| <b>SUPPLY</b>                         |                                       |  |                              |     |                 |       |          |
| Positive Supply Current               | $I_+$                                 | $V_+ = 3.6V$ , $V_{IN} = 0V$ or $V_+$ , all channels on or off     |                              | -1  |                 | 1     | $\mu A$  |

**Note 2:** The algebraic convention, where the most negative value is a minimum and the most positive value a maximum, is used in this data sheet.

**Note 3:** Guaranteed by design.

**Note 4:**  $\Delta R_{ON} = \Delta R_{ON\ max} - \Delta R_{ON\ min}$ .

**Note 5:** Flatness is defined as the difference between the maximum and minimum value of on-resistance as measured over the specified analog signal range.

**Note 6:** Leakage parameters are 100% tested at maximum rated hot temperature and guaranteed by correlation at  $+25^\circ C$ .

**Note 7:** Off Isolation =  $20 \log_{10} [V_{COM} / (V_{NC} \text{ or } V_{NO})]$ ,  $V_{COM}$  = output,  $V_{NC}$  or  $V_{NO}$  = input to off switch.

**Note 8:** Between any two switches.

# Precision, Single-Supply, SPST Analog Switches

## Typical Operating Characteristics

( $T_A = +25^\circ\text{C}$ , unless otherwise noted.)

MAX323/MAX324/MAX325

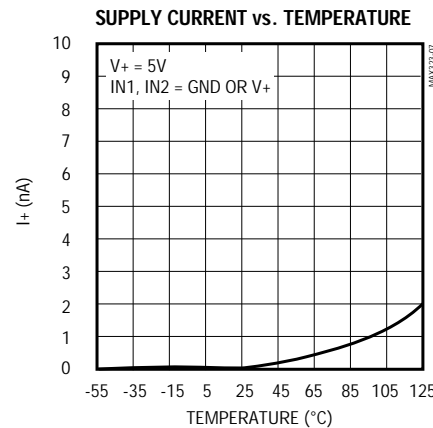
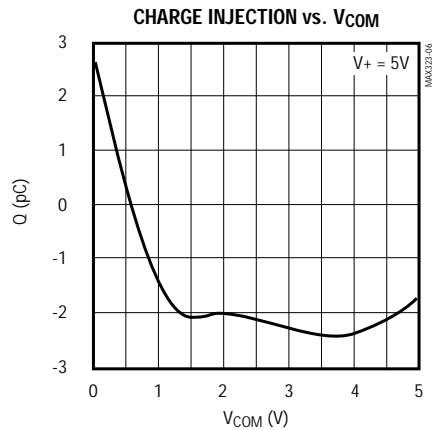
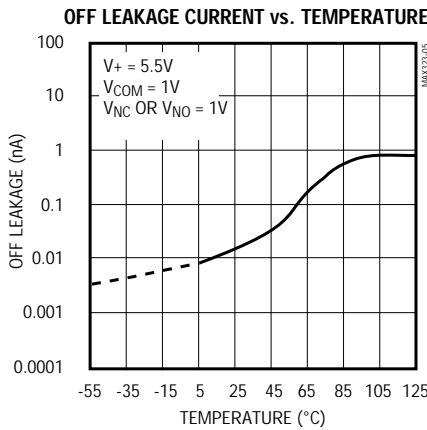
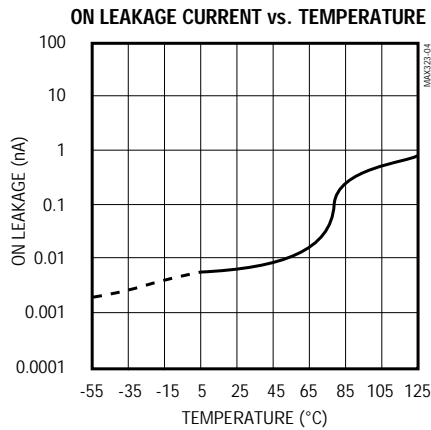
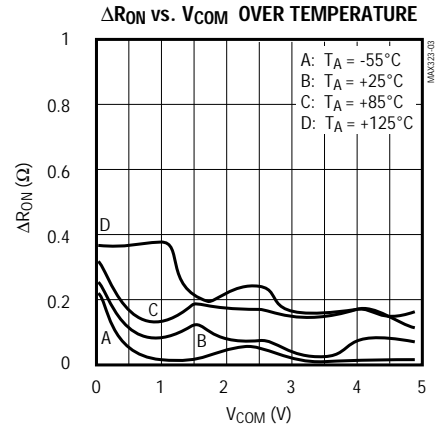
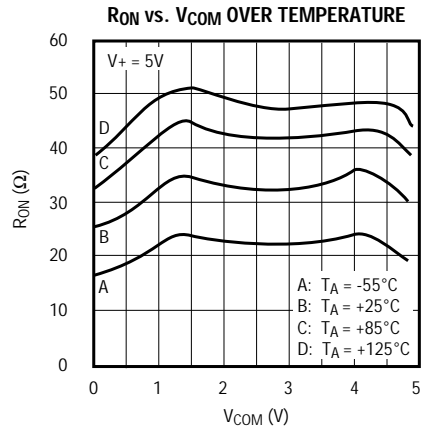
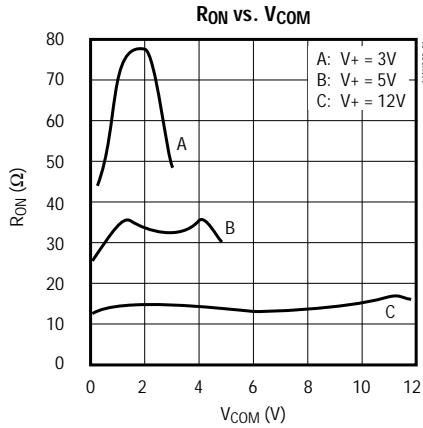

# Precision, Single-Supply, SPST Analog Switches

## Pin Description

| PIN  | NAME       | FUNCTION   |
|------|------------|--|
| 1    | NO1        | Normally Open Analog Switch Terminal (MAX323/MAX325)   |
|      | NC1        | Normally Closed Analog Switch Terminal (MAX324 only)   |
| 2, 6 | COM1, COM2 | Analog Switch Common Terminal                          |
| 3, 7 | IN2, IN1   | Logic Inputs   |
| 4    | GND        | Ground   |
| 5    | NO2        | Normally Open Analog Switch Terminal (MAX323 only)     |
|      | NC2        | Normally Closed Analog Switch Terminal (MAX324/MAX325) |
| 8    | V+         | Positive Supply  |

## Applications Information

### Logic Levels

The MAX323/MAX324/MAX325 are TTL compatible when powered from a single +5V supply. When powered from other supply voltages, TTL compatibility is not guaranteed, and the logic inputs should be driven from rail to rail. For example, with a 15V supply, IN1 and IN2 should be driven low to 0V and high to 15V. Similarly, with a 3.3V supply, IN1 and IN2 should be driven low to 0V and high to 3.3V.

Driving IN1 and IN2 rail-to-rail minimizes power consumption.

### Analog Signal Levels

Analog signals that range over the entire supply voltage (V+ to GND) can be switched with very little change in on-resistance over the entire voltage range (see *Typical Operating Characteristics*). All the switches are bidirectional, so NO\_, NC\_, and COM\_ pins can be used as either inputs or outputs.

### Power-Supply Sequencing and Overvoltage Protection

Do not exceed the absolute maximum ratings, because stresses beyond the listed ratings may cause permanent damage to the devices.

Proper power-supply sequencing is recommended for all CMOS devices. Always apply V+ before applying analog signals or logic inputs, especially if the analog

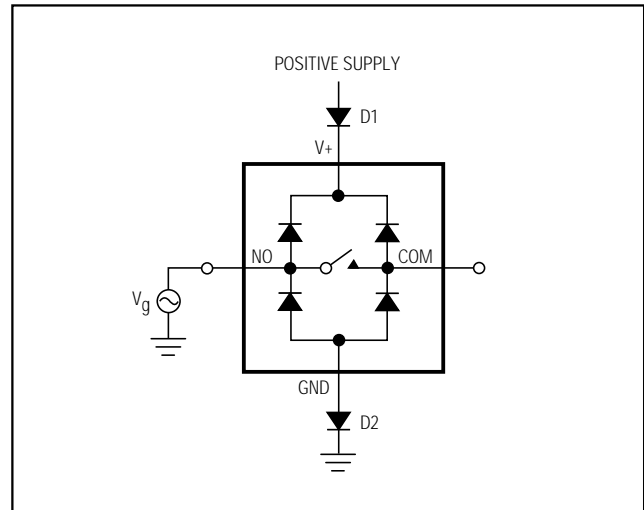

Figure 1. Overvoltage Protection Using Two External Blocking Diodes

or logic signals are not current-limited. If this sequencing is not possible, and if the analog or logic inputs are not current-limited to <30mA, add a small-signal diode (D1) as shown in Figure 1. If the analog signal can dip below GND, add D2. Adding protection diodes reduces the analog signal range to a diode-drop (about 0.7V) below V+ (for D1), and to a diode-drop above ground (for D2). Leakage is unaffected by adding the diodes. On-resistance increases by a small amount at low supply voltages. Maximum supply voltage (V+) must not exceed 17V.

Adding protection diodes causes the logic thresholds to be shifted relative to the power-supply rails. This can be significant when low supply voltages (5V or less) are used. With a 5V supply, TTL compatibility is not guaranteed when protection diodes are added. Driving IN1 and IN2 all the way to the supply rails (i.e. to a diode-drop higher than the V+ pin, or to a diode-drop lower than the GND pin) is always acceptable.

Protection diodes D1 and D2 also protect against some overvoltage situations. With Figure 1's circuit, if the supply voltage is below the absolute maximum rating, and if a fault voltage up to the absolute maximum rating is applied to an analog signal pin, no damage will result. For example, with a +5V supply, analog signals up to  $\pm 8V$  will not damage the circuit of Figure 1. If only a single fault signal is present, the fault voltage can rise to +17V or to -12V without damage occurring.

# Precision, Single-Supply, SPST Analog Switches

## Test Circuits/Timing Diagrams

MAX323/MAX324/MAX325

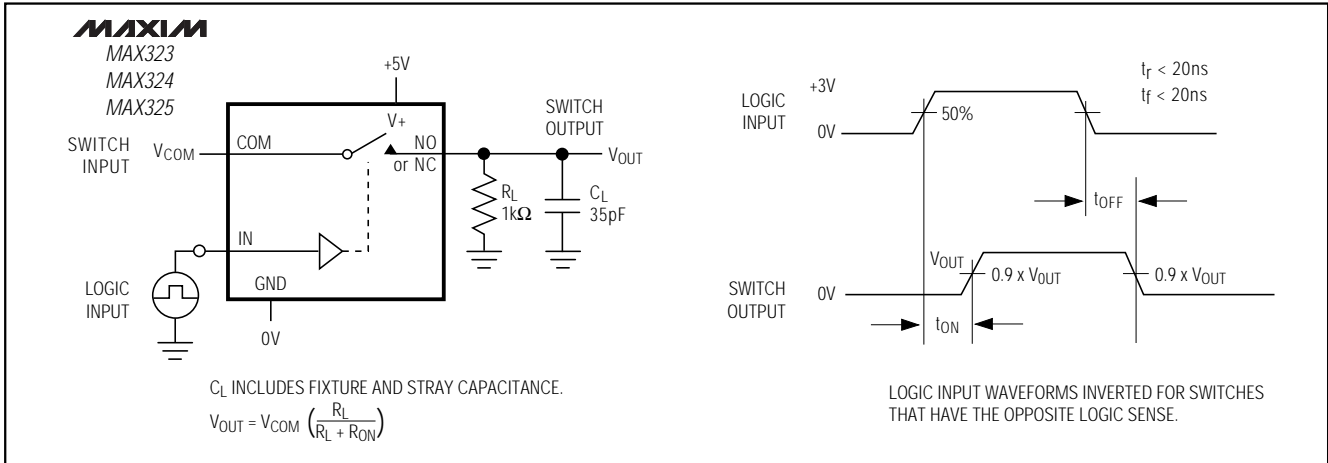

Figure 2. Switching Time

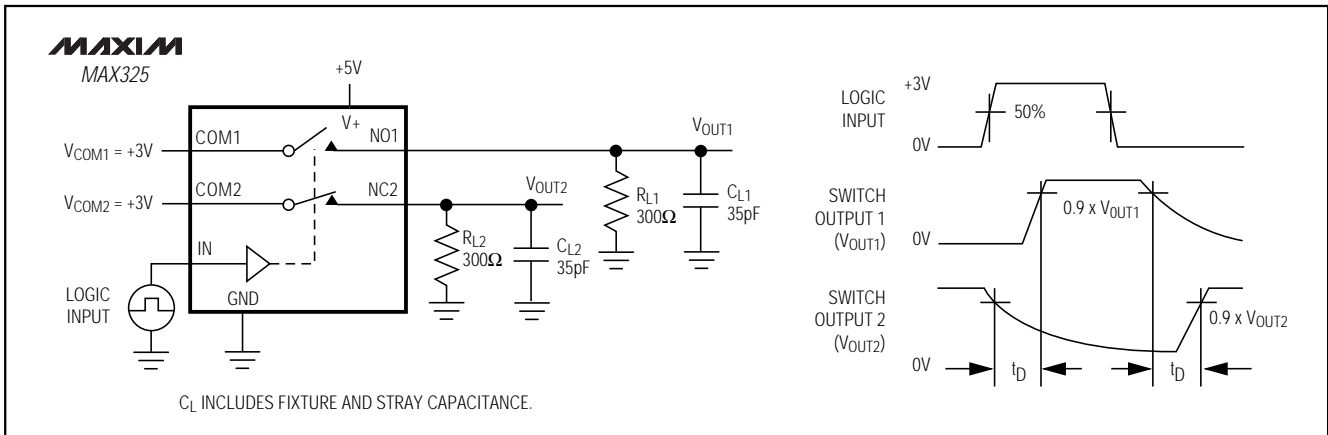

Figure 3. Break-Before-Make Interval (MAX325 only)

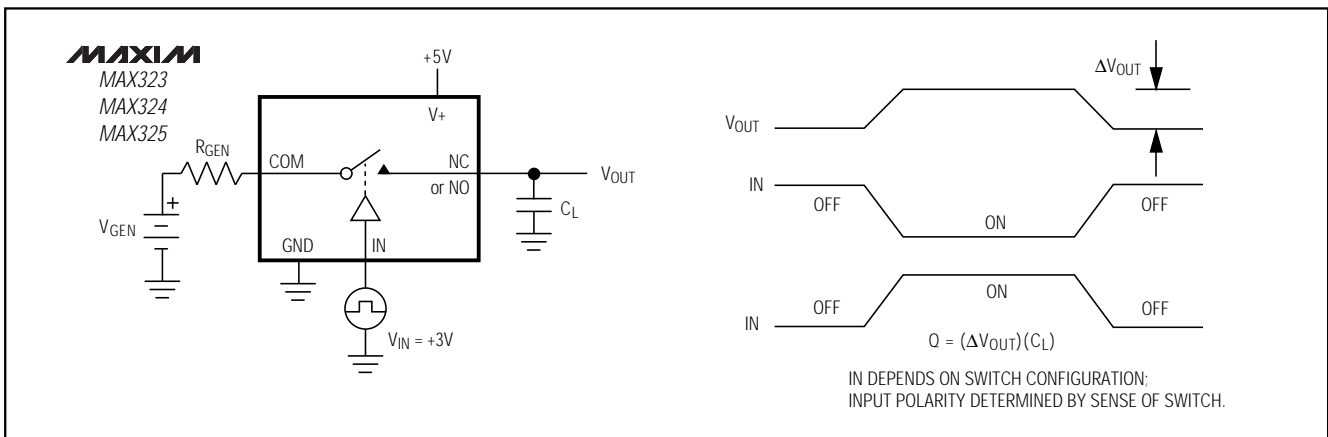

Figure 4. Charge Injection

# Precision, Single-Supply, SPST Analog Switches

## Test Circuits/Timing Diagrams (continued)

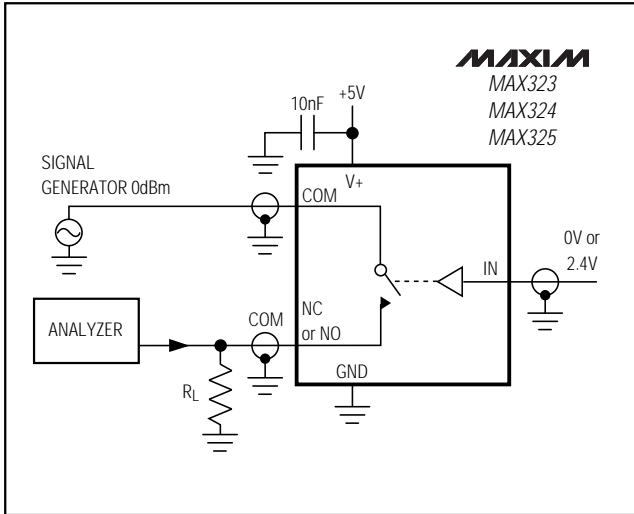

Figure 5. Off Isolation

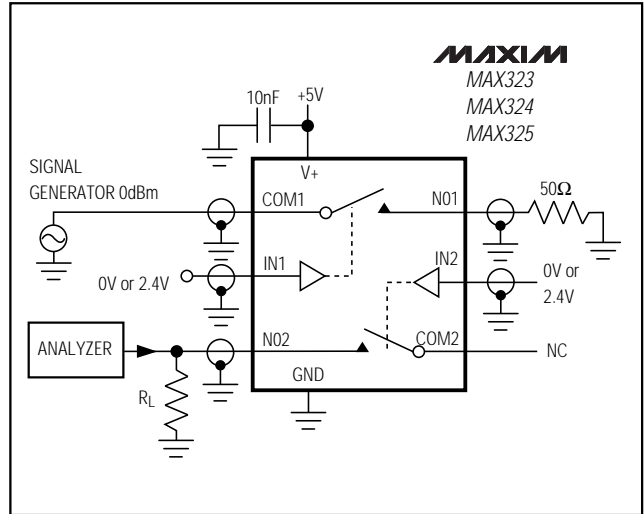

Figure 6. Crosstalk

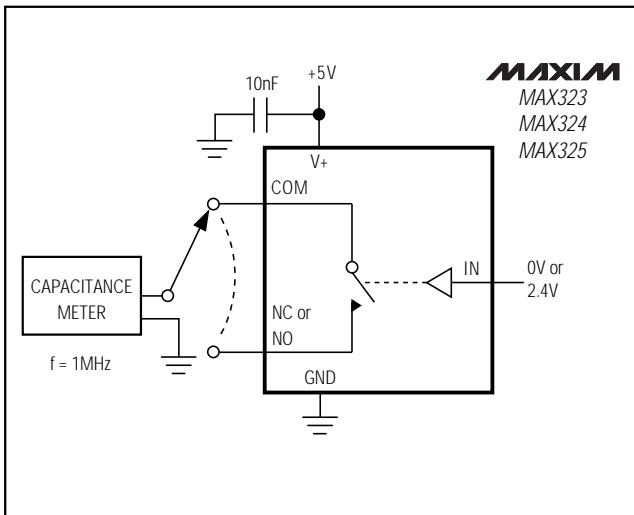

Figure 7. Channel-Off Capacitance

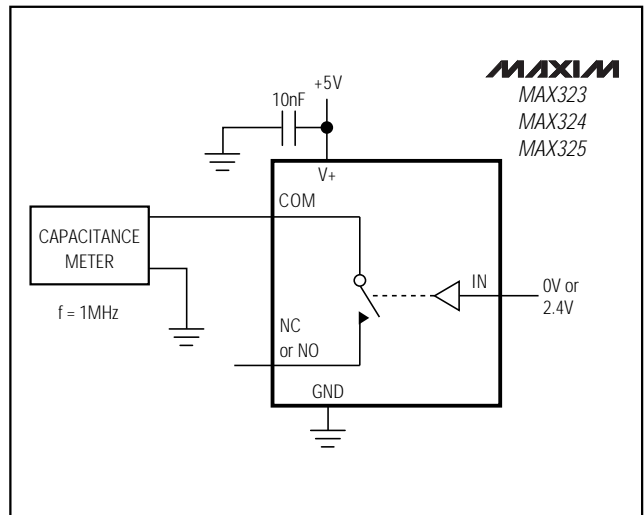

Figure 8. Channel-On Capacitance

# Precision, Single-Supply, SPST Analog Switches

## Ordering Information (continued)

| PART              | TEMP. RANGE     | PIN-PACKAGE   |
|-------------------|-----------------|---------------|
| <b>MAX324</b> CPA | 0°C to +70°C    | 8 Plastic DIP |
| MAX324CUA         | 0°C to +70°C    | 8 $\mu$ MAX   |
| MAX324CSA         | 0°C to +70°C    | 8 SO          |
| MAX324C/D         | 0°C to +70°C    | Dice*         |
| MAX324EPA         | -40°C to +85°C  | 8 Plastic DIP |
| MAX324ESA         | -40°C to +85°C  | 8 SO          |
| MAX324EJA         | -40°C to +85°C  | 8 CERDIP**    |
| MAX324MJA         | -55°C to +125°C | 8 CERDIP**    |
| <b>MAX325</b> CPA | 0°C to +70°C    | 8 Plastic DIP |
| MAX325CUA         | 0°C to +70°C    | 8 $\mu$ MAX   |
| MAX325CSA         | 0°C to +70°C    | 8 SO          |
| MAX325C/D         | 0°C to +70°C    | Dice*         |
| MAX325EPA         | -40°C to +85°C  | 8 Plastic DIP |
| MAX325ESA         | -40°C to +85°C  | 8 SO          |
| MAX325EJA         | -40°C to +85°C  | 8 CERDIP**    |
| MAX325MJA         | -55°C to +125°C | 8 CERDIP**    |

\* Contact factory for dice specifications.

\*\* Contact factory for availability.

## Chip Topography

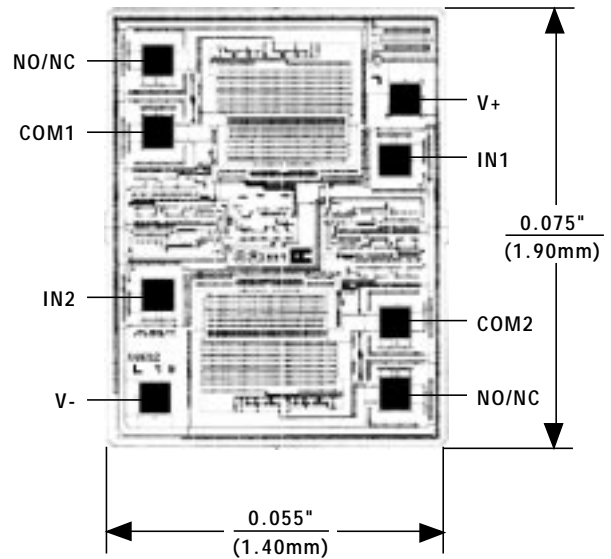

MAX323/MAX324/MAX325

TRANSISTOR COUNT: 91  
SUBSTRATE IS CONNECTED TO V+

# Precision, Single-Supply, SPST Analog Switches

## Package Information

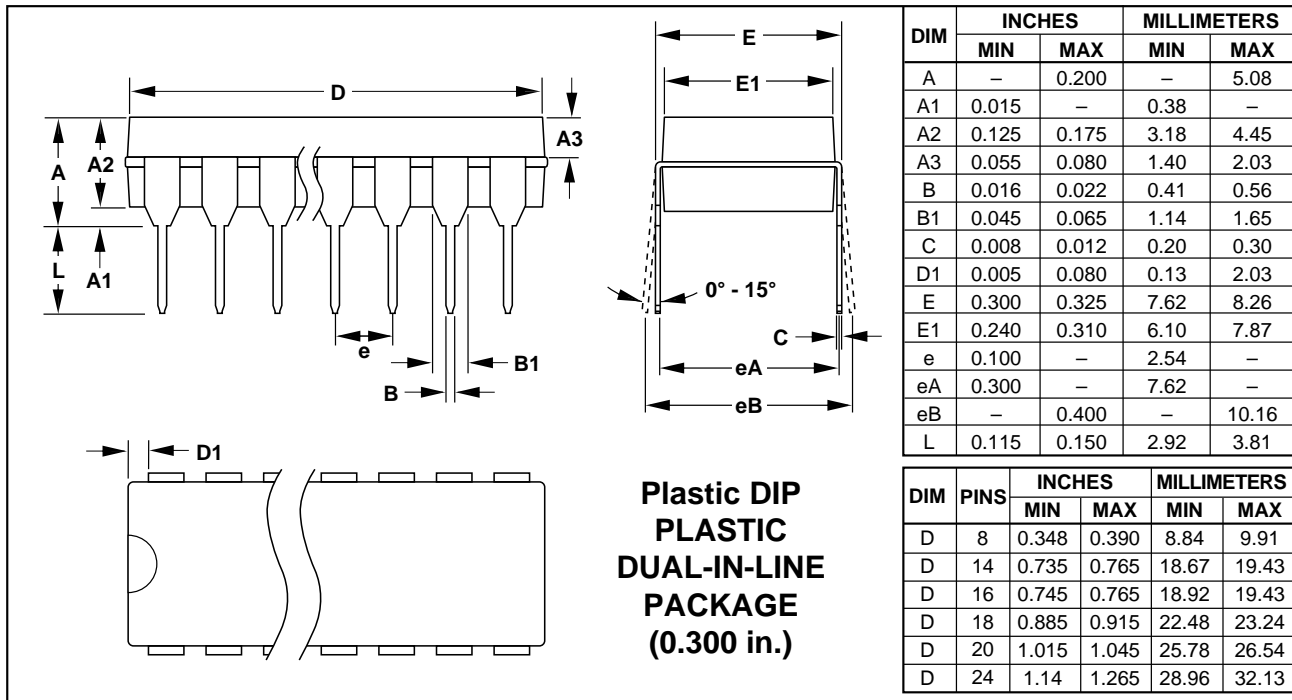
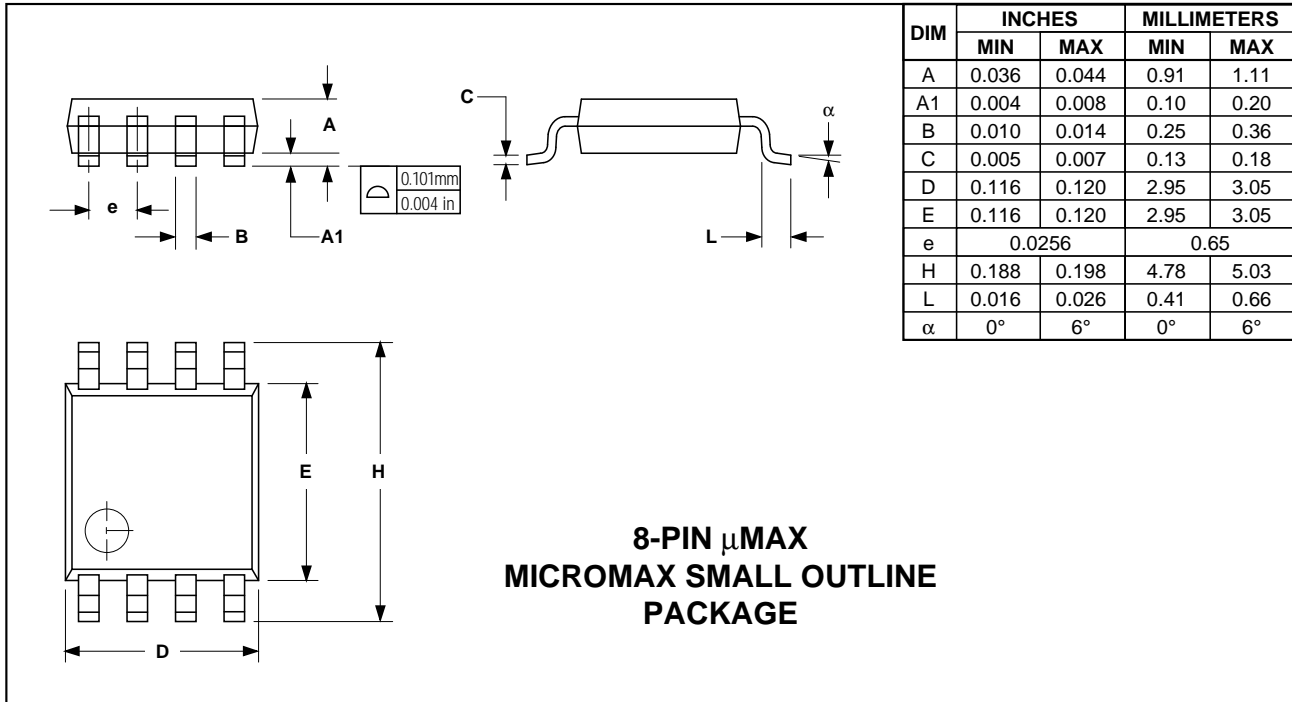

# Precision, Single-Supply, SPST Analog Switches

Package Information (continued)

MAX323/MAX324/MAX325

**SO SMALL OUTLINE PACKAGE (0.150 in.)**

| DIM | INCHES |       | MILLIMETERS |      |
|-----|--------|-------|-------------|------|
|     | MIN    | MAX   | MIN         | MAX  |
| A   | 0.053  | 0.069 | 1.35        | 1.75 |
| A1  | 0.004  | 0.010 | 0.10        | 0.25 |
| B   | 0.014  | 0.019 | 0.35        | 0.49 |
| C   | 0.007  | 0.010 | 0.19        | 0.25 |
| E   | 0.150  | 0.157 | 3.80        | 4.00 |
| e   | 0.050  |       | 1.27        |      |
| H   | 0.228  | 0.244 | 5.80        | 6.20 |
| L   | 0.016  | 0.050 | 0.40        | 1.27 |

| DIM | PINS | INCHES |       | MILLIMETERS |       |
|-----|------|--------|-------|-------------|-------|
|     |      | MIN    | MAX   | MIN         | MAX   |
| D   | 8    | 0.189  | 0.197 | 4.80        | 5.00  |
| D   | 14   | 0.337  | 0.344 | 8.55        | 8.75  |
| D   | 16   | 0.386  | 0.394 | 9.80        | 10.00 |

21-0041A

# Precision, Single-Supply, SPST Analog Switches

Package Information (continued)

**Ceramic SB  
CERAMIC SIDEBRAZE  
PACKAGE  
(0.300 in.)**

| DIM | INCHES |       | MILLIMETERS |      |
|-----|--------|-------|-------------|------|
|     | MIN    | MAX   | MIN         | MAX  |
| A   | –      | 0.225 | –           | 5.72 |
| B   | 0.014  | 0.023 | 0.36        | 0.58 |
| B2  | 0.038  | 0.065 | 0.97        | 1.65 |
| C   | 0.008  | 0.015 | 0.20        | 0.38 |
| E   | 0.220  | 0.310 | 5.59        | 7.87 |
| eA  | 0.290  | 0.320 | 7.37        | 8.13 |
| e   | 0.100  |       | 2.54        |      |
| L   | 0.125  | 0.200 | 3.18        | 5.08 |
| Q   | 0.015  | 0.070 | 0.38        | 1.78 |
| S1  | 0.005  | –     | 0.13        | –    |

| DIM | PINS | INCHES |       | MILLIMETERS |       |
|-----|------|--------|-------|-------------|-------|
|     |      | MIN    | MAX   | MIN         | MAX   |
| D   | 8    | –      | 0.550 | –           | 13.97 |
| D   | 14   | –      | 0.785 | –           | 19.94 |
| D   | 16   | –      | 0.840 | –           | 21.34 |
| D   | 18   | –      | 0.960 | –           | 24.38 |
| D   | 20   | –      | 1.060 | –           | 26.92 |
| D   | 24   | –      | 1.280 | –           | 32.51 |

Maxim cannot assume responsibility for use of any circuitry other than circuitry entirely embodied in a Maxim product. No circuit patent licenses are implied. Maxim reserves the right to change the circuitry and specifications without notice at any time.

12 \_\_\_\_\_ Maxim Integrated Products, 120 San Gabriel Drive, Sunnyvale, CA 94086 408-737-7600