

Distributed by:

**JAMECO**<sup>®</sup>  
ELECTRONICS

**www.Jameco.com ♦ 1-800-831-4242**

The content and copyrights of the attached  
material are the property of its owner.

Jameco Part Number 2058311



# 8-Channel/Dual 4-Channel, Low-Leakage, CMOS Analog Multiplexers

MAX338/MAX339

## General Description

The MAX338/MAX339 are monolithic, CMOS analog multiplexers (muxes). The 8-channel MAX338 is designed to connect one of eight inputs to a common output by control of a 3-bit binary address. The dual, 4-channel MAX339 is designed to connect one of four inputs to a common output by control of a 2-bit binary address. Both devices can be used as either a mux or a demux. On-resistance is 400Ω max, and the devices conduct current equally well in both directions.

These muxes feature extremely low off leakages (less than 20pA at +25°C), and extremely low on-channel leakages (less than 50pA at +25°C). The new design offers guaranteed low charge injection (1.5pC typ) and electrostatic discharge (ESD) protection greater than 2000V, per method 3015.7. These improved muxes are pin-compatible upgrades for the industry-standard DG508A and DG509A. For similar Maxim devices with lower leakage and charge injection but higher on-resistance, see the MAX328 and MAX329.

The MAX338/MAX339 operate from a single +4.5V to +30V supply or from dual supplies of ±4.5V to ±20V. All control inputs (whether address or enable) are TTL compatible (+0.8V to +2.4V) over the full specified temperature range and over the ±4.5V to ±18V supply range. These parts are fabricated with Maxim's 44V silicon-gate process.

## Applications

- |                              |                          |
|------------------------------|--------------------------|
| Data-Acquisition Systems     | Sample-and-Hold Circuits |
| Test Equipment               | Heads-Up Displays        |
| Military Radios              | Communications Systems   |
| Guidance and Control Systems | PBX, PABX                |

## Features

- ◆ On-Resistance, <400Ω max
- ◆ Transition Time, <500ns
- ◆ On-Resistance Match, <10Ω
- ◆ NO-Off Leakage Current, <20pA at +25°C
- ◆ 1.5pC Charge Injection
- ◆ Single-Supply Operation (+4.5V to +30V)  
Bipolar-Supply Operation (±4.5V to ±20V)
- ◆ Plug-In Upgrade for Industry-Standard DG508A/DG509A
- ◆ Rail-to-Rail Signal Handling
- ◆ TTL/CMOS-Logic Compatible
- ◆ ESD Protection >2000V, per Method 3015.7

## Ordering Information

PART	TEMP RANGE	PIN-PACKAGE
MAX338CPE	0°C to +70°C	16 Plastic DIP
MAX338CSE	0°C to +70°C	16 Narrow SO
MAX338C/D	0°C to +70°C	Dice*
MAX338ETE	-40°C to +85°C	16 Thin QFN (5mm x 5mm)
MAX338EPE	-40°C to +85°C	16 Plastic DIP
MAX338ESE	-40°C to +85°C	16 Narrow SO
MAX338EJE	-40°C to +85°C	16 CERDIP
MAX338MJE	-55°C to +125°C	16 CERDIP**

**Ordering Information continued at end of data sheet.**  
 \*Contact factory for dice specifications.  
 \*\*Contact factory for availability.

## Pin Configurations/Functional Diagrams/Truth Tables

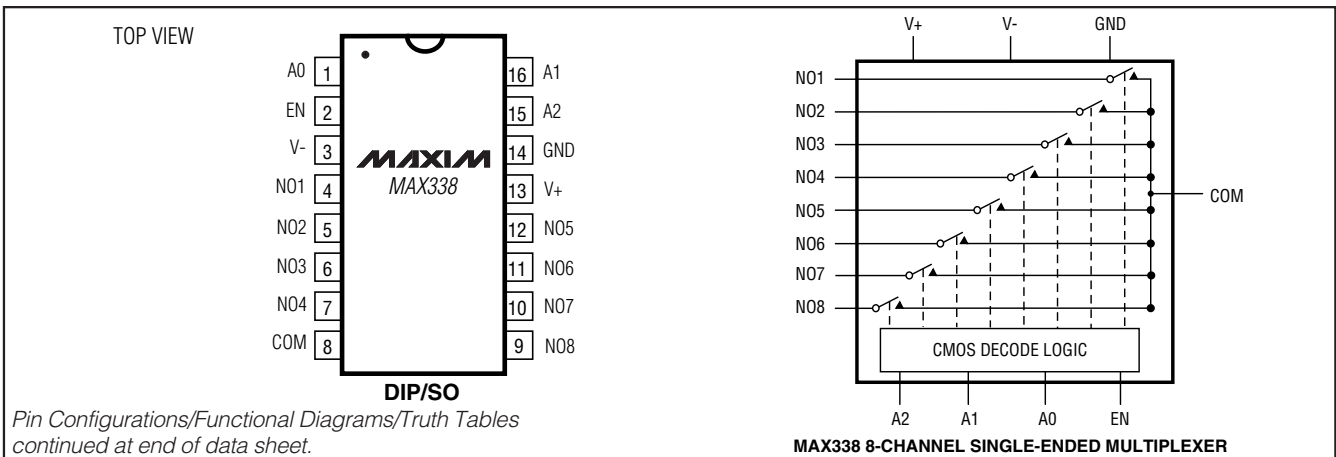

**For pricing, delivery, and ordering information, please contact Maxim/Dallas Direct! at 1-888-629-4642, or visit Maxim's website at [www.maxim-ic.com](http://www.maxim-ic.com).**

# 8-Channel/Dual 4-Channel, Low-Leakage, CMOS Analog Multiplexers

## ABSOLUTE MAXIMUM RATINGS

Voltage Referenced to V-

V+ .....-0.3V, 44V

GND .....-0.3V, 25V

Digital Inputs, NO, COM (Note 1).....(V- - 2V) to (V+ + 2V) or  
30mA (whichever occurs first)

Continuous Current (any terminal) .....30mA

Peak Current, NO or COM

(pulsed at 1ms, 10% duty cycle max) .....100mA

Continuous Power Dissipation (TA = +70°C)

Plastic DIP (derate 10.53mW/°C above +70°C) .....842mW

Narrow SO (derate 8.70mW/°C above +70°C) .....696mW

16-Pin TQFN (derate 21.3mW/°C above +70°C) .....1702mW

CERDIP (derate 10.00mW/°C above +70°C) .....800mW

Operating Temperature Ranges

MAX33\_C\_ .....0°C to +70°C

MAX33\_E\_ .....-40°C to +85°C

MAX33\_MJE .....-55°C to +125°C

Storage Temperature Range .....-65°C to +150°C

Lead Temperature (soldering, 10sec) .....+300°C

**Note 1:** Signals on NO, COM, EN, A0, A1, or A2 exceeding V+ or V- are clamped by internal diodes. Limit forward current to maximum current ratings.

Stresses beyond those listed under "Absolute Maximum Ratings" may cause permanent damage to the device. These are stress ratings only, and functional operation of the device at these or any other conditions beyond those indicated in the operational sections of the specifications is not implied. Exposure to absolute maximum rating conditions for extended periods may affect device reliability.

## ELECTRICAL CHARACTERISTICS—Dual Supplies

(V+ = +15V, V- = -15V, GND = 0V, VAH = +2.4V, VAL = +0.8V, TA = TMIN to TMAX, unless otherwise noted.)

PARAMETER	SYMBOL	CONDITIONS		MIN	TYP (Note 2)	MAX	UNITS	
<b>SWITCH</b>								
Analog Signal Range	VNO, VCOM	(Note 3)		-15		15	V	
On-Resistance	RON	INO = 0.2mA, VCOM = ±10V		TA = +25°C	220	400	Ω	
				TA = TMIN to TMAX		500		
On-Resistance Matching Between Channels	ΔRON	INO = 0.2mA, VCOM = ±10V (Note 4)		TA = +25°C	4	10	Ω	
				TA = TMIN to TMAX		15		
NO-Off Leakage Current (Note 5)	INO(OFF)	VCOM = ±10V, VNO = ±10V, VEN = 0V		TA = +25°C	-0.02	0.001	0.02	nA
				TA = TMIN to TMAX	C, E	-1.25	1.25	
					M	-20	20	
COM-Off Leakage Current (Note 5)	ICOM(OFF)	VNO = ±10V, VCOM = ±10V, VEN = 0V	MAX338	TA = +25°C	-0.05	0.005	0.05	nA
				TA = TMIN to TMAX	C, E	-3.25	3.25	
			M		-40	40		
			MAX339	TA = +25°C	-0.05	0.005	0.05	
				TA = TMIN to TMAX	C, E	-1.65	1.65	
			M	-20	20			
COM-On Leakage Current (Note 5)	ICOM(ON)	VCOM = ±10V, VNO = ±10V, sequence each switch on	MAX338	TA = +25°C	-0.05	0.006	0.05	nA
				TA = TMIN to TMAX	C, E	-3.25	3.25	
			M		-40	40		
			MAX339	TA = +25°C	-0.05	0.008	0.05	
				TA = TMIN to TMAX	C, E	-1.65	1.65	
			M	-20	20			

# 8-Channel/Dual 4-Channel, Low-Leakage, CMOS Analog Multiplexers

**MAX3338/MAX3339**

## ELECTRICAL CHARACTERISTICS—Dual Supplies (continued)

(V+ = +15V, V- = -15V, GND = 0V, VAH = +2.4V, VAL = +0.8V, TA = TMIN to TMAX, unless otherwise noted.)

PARAMETER	SYMBOL	CONDITIONS		MIN	TYP (Note 2)	MAX	UNITS
<b>INPUT</b>							
Input Current with Input Voltage High	IAH	VA = 2.4V or 15V		-1.0	0.001	1.0	μA
Input Current with Input Voltage Low	I <sub>AL</sub>	VEN = 0V or 2.4V, VA = 0V		-1.0		1.0	μA
<b>SUPPLY</b>							
Power-Supply Range				±4.5		±20	V
Positive Supply Current	I+	VEN = VA = 0V	TA = +25°C		50	100	μA
			TA = TMIN to TMAX			150	
Negative Supply Current	I-	VEN = 0V or 2.4V, VA(ALL) = 2.4V	TA = +25°C		290	500	μA
			TA = TMIN to TMAX			600	
Positive Supply Current	I+	VEN = 0V or 2.4V, VA(ALL) = 0V, 2.4V or 5V	TA = +25°C		-1	1	μA
			TA = TMIN to TMAX			-10	
<b>DYNAMIC</b>							
Transition Time	tTRANS	Figure 2	TA = +25°C		200	500	ns
Break-Before-Make Interval	tOPEN	Figure 4	TA = +25°C	10	140		ns
Enable Turn-On Time	tON(EN)	Figure 3	TA = +25°C		160	500	ns
			TA = TMIN to TMAX			750	
Enable Turn-Off Time	tOFF(EN)	Figure 3	TA = +25°C		100	500	ns
			TA = TMIN to TMAX			750	
Charge Injection (Note 3)	Q	CL = 100pF, VNO = 0V, RS = 0Ω, Figure 6	TA = +25°C		1.5	5	pC
Off Isolation (Note 6)	VISO	VEN = 0V, RL = 1kΩ, f = 100kHz	TA = +25°C		-75		dB
Crosstalk Between Channels	VCT	VEN = 2.4V, f = 100kHz, VGEN = 1VP-P, RL = 1kΩ, Figure 7	TA = +25°C		-92		dB
Logic Input Capacitance	CIN	f = 1MHz	TA = +25°C		2		pF
NO-Off Capacitance	CNO(OFF)	f = 1MHz, VEN = VNO = 0V, Figure 8	TA = +25°C		3		pF
COM-Off Capacitance	CCOM(OFF)	f = 1MHz, VEN = 0.8V, VCOM = 0V, Figure 8	MAX338	TA = +25°C	11		pF
			MAX339		6		
COM-On Capacitance	CCOM(ON)	f = 1MHz, VEN = 2.4V, VCOM = 0V, Figure 8	MAX338	TA = +25°C	16		pF
			MAX339		9		

# 8-Channel/Dual 4-Channel, Low-Leakage, CMOS Analog Multiplexers

## ELECTRICAL CHARACTERISTICS—Single Supply

(V+ = +12V, V- = 0V, GND = 0V, V<sub>AH</sub> = +2.4V, V<sub>AL</sub> = +0.8V, T<sub>A</sub> = T<sub>MIN</sub> to T<sub>MAX</sub>, unless otherwise noted.)

PARAMETER	SYMBOL	CONDITIONS		MIN	TYP (Note 2)	MAX	UNITS
<b>SWITCH</b>							
Analog Signal Range	V <sub>NO</sub> , V <sub>COM</sub>	(Note 3)		0		12	V
On-Resistance	R <sub>ON</sub>	I <sub>NO</sub> = 0.2mA V <sub>COM</sub> = 3V or 10V	T <sub>A</sub> = +25°C		460	650	Ω
<b>DYNAMIC</b>							
Transition Time (Note 3)	t <sub>TRANS</sub>	V <sub>NO1</sub> = 8V, V <sub>NO8</sub> = 0V, V <sub>IN</sub> = 2.4V, Figure 1	T <sub>A</sub> = +25°C		210	500	ns
Enable Turn-On Time (Note 3)	t <sub>ON(EN)</sub>	V <sub>INH</sub> = 2.4V, V <sub>INL</sub> = 0V, V <sub>NO1</sub> = 5V, Figure 3	T <sub>A</sub> = +25°C		280	500	ns
Enable Turn-Off Time (Note 3)	t <sub>OFF(EN)</sub>	V <sub>INH</sub> = 2.4V, V <sub>INL</sub> = 0V, V <sub>NO1</sub> = 5V, Figure 3	T <sub>A</sub> = +25°C		110	500	ns
Charge Injection (Note 3)	Q	C <sub>L</sub> = 100pF, V <sub>NO</sub> = 0V, R <sub>S</sub> = 0Ω	T <sub>A</sub> = +25°C		1.8	5	pC

**Note 2:** The algebraic convention where the most negative value is a minimum and the most positive value a maximum is used in this data sheet.

**Note 3:** Guaranteed by design.

**Note 4:**  $\Delta R_{ON} = R_{ON(MAX)} - R_{ON(MIN)}$ .

**Note 5:** Leakage parameters are 100% tested at the maximum rated hot temperature and guaranteed by correlation at +25°C.

**Note 6:** Worst-case isolation is on channel 4 because of its proximity to the drain pin. Off isolation =  $20 \log V_{COM}/V_{NO}$ , where V<sub>COM</sub> = output and V<sub>NO</sub> = input to off switch.

# 8-Channel/Dual 4-Channel, Low-Leakage, CMOS Analog Multiplexers

## Typical Operating Characteristics

( $T_A = +25^\circ\text{C}$ , unless otherwise noted.)

MAX3338/MAX3339

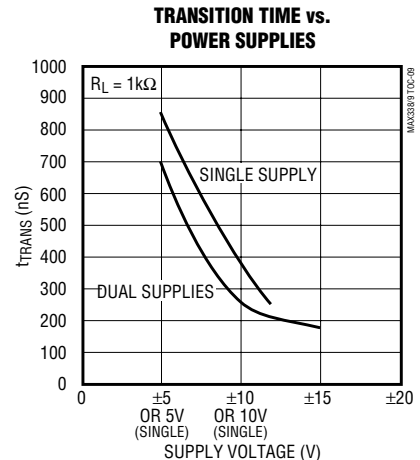
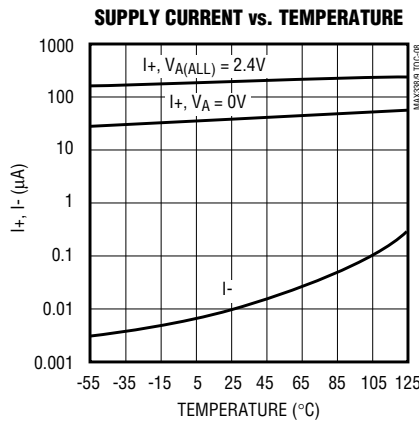
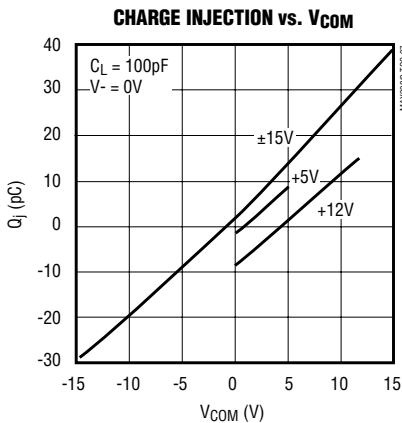
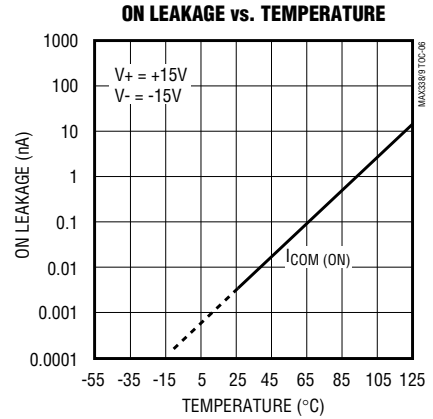
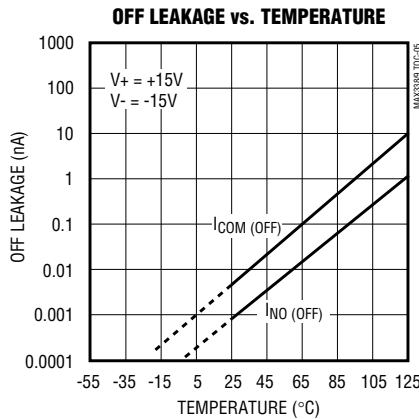
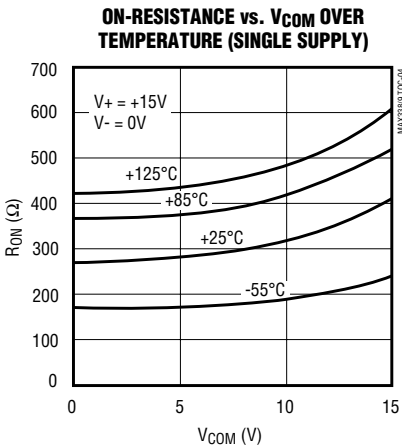
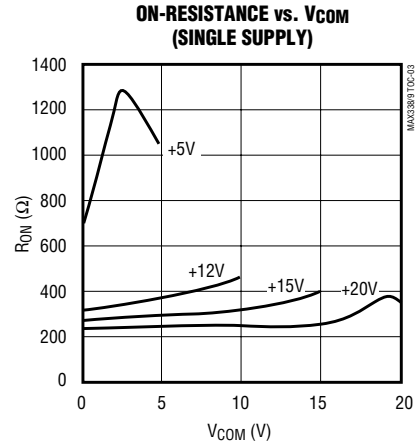
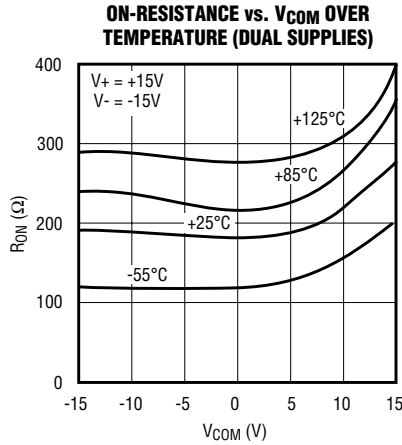
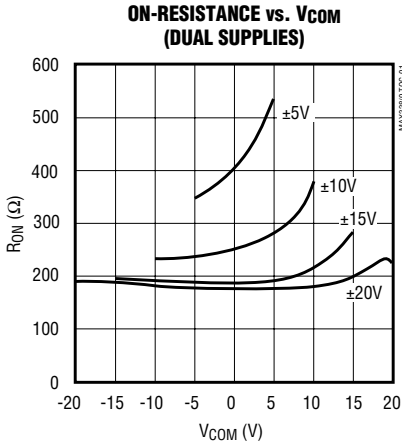

# 8-Channel/Dual 4-Channel, Low-Leakage, CMOS Analog Multiplexers

## Pin Description

PIN				NAME	FUNCTION
MAX338		MAX339			
DIP/SO	THIN QFN	DIP/SO	THIN QFN		
1, 15, 16,	15, 14, 13	—	—	A0, A2, A1	Address Inputs
—	—	1, 16	15, 14	A0, A1	Address Inputs
2	16	2	16	EN	Enable
3	1	3	1	V-	Negative-Supply Voltage Input
4–7	2–5	—	—	NO1–NO14	Analog Inputs—Bidirectional
—	—	4–7	2–5	NO1A–NO4A	Analog Inputs—Bidirectional
8	6	—	—	COM	Analog Output—Bidirectional
—	—	8, 9	6, 7	COMA, COMB	Analog Outputs—Bidirectional
9–12	7–10	—	—	NO8–NO5	Analog Inputs—Bidirectional
—	—	10–3	8–11	NO4B–NO1B	Analog Inputs—Bidirectional
13	11	14	12	V+	Positive-Supply Voltage Input
14	12	15	13	GND	Ground
—	EP	—	EP	Exposed Pad	Exposed Pad. Connect to V+.

## Applications Information

### Operation with Supply Voltages Other than 15V

Using supply voltages less than  $\pm 15\text{V}$  will reduce the analog signal range. The MAX338/MAX339 switches operate with  $\pm 4.5\text{V}$  to  $\pm 20\text{V}$  bipolar supplies or with a  $+4.5\text{V}$  to  $+30\text{V}$  single supply. Connect V- to GND when operating with a single supply. Both device types can also operate with unbalanced supplies such as  $+24\text{V}$  and  $-5\text{V}$ . The *Typical Operating Characteristics* graphs show typical on-resistance with 20V, 15V, 10V, and 5V supplies. (Switching times increase by a factor of two or more for operation at 5V.)

### Overvoltage Protection

Proper power-supply sequencing is recommended for all CMOS devices. Do not exceed the absolute maximum ratings, because stresses beyond the listed ratings may cause permanent damage to the devices. Always sequence V+ on first, then V-, followed by the logic inputs NO and COM. If power-supply sequencing is not possible, add two small signal diodes in series with supply pins for overvoltage protection (Figure 1). Adding diodes reduces the analog signal range to 1V below V+ and 1V above V-, but does not affect the devices' low switch resistance and low leakage characteristics. Device operation is unchanged, and the difference between V+ and V- should not exceed 44V.

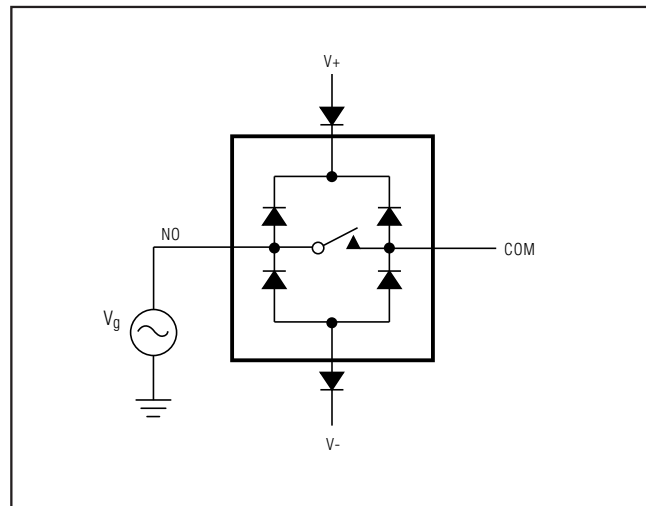

Figure 1. Overvoltage Protection Using External Blocking Diodes

# 8-Channel/Dual 4-Channel, Low-Leakage, CMOS Analog Multiplexers

## Test Circuits/Timing Diagrams

MAX3338/MAX3339

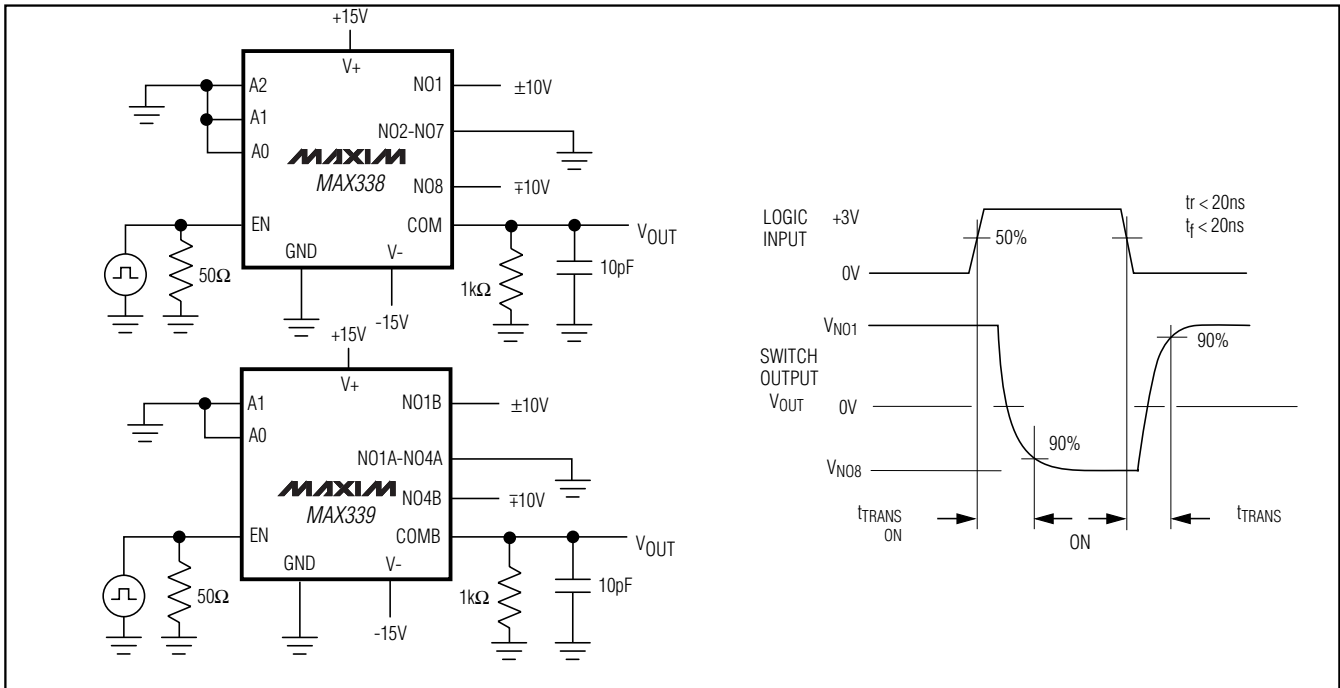

Figure 2. Transition Time

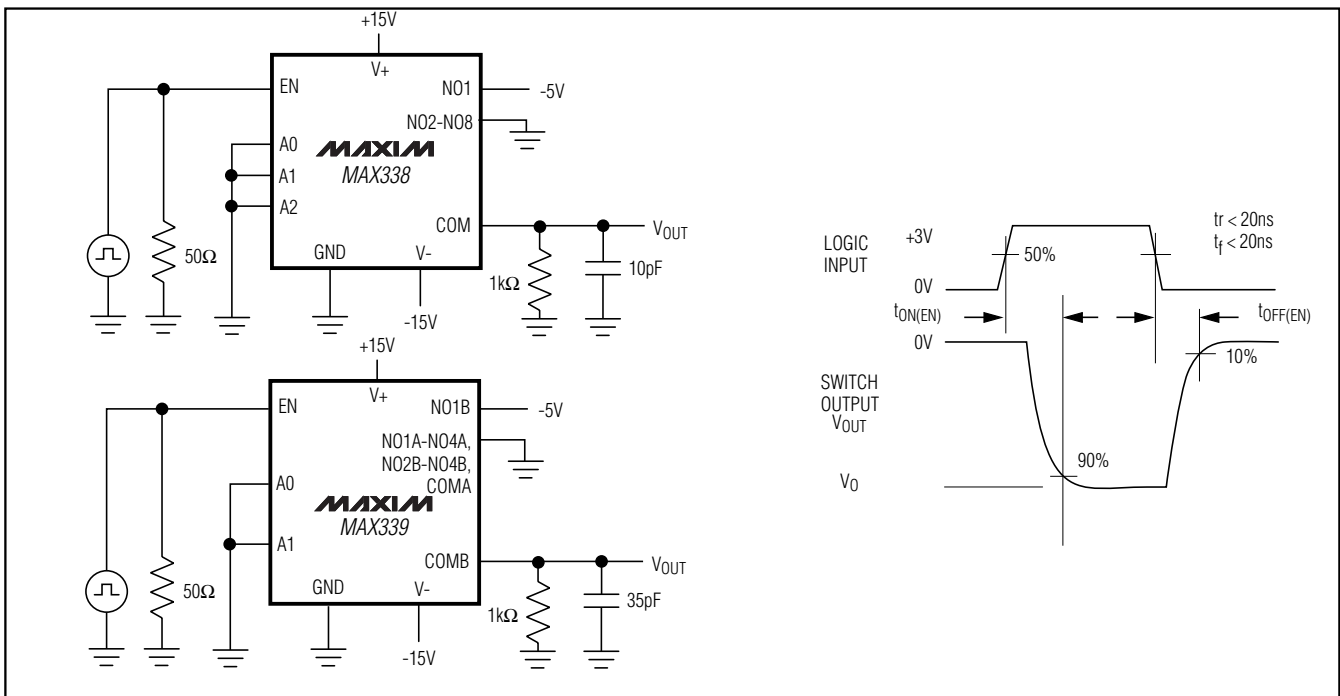

Figure 3. Enable Switching Time

# 8-Channel/Dual 4-Channel, Low-Leakage, CMOS Analog Multiplexers

## Test Circuits/Timing Diagrams (continued)

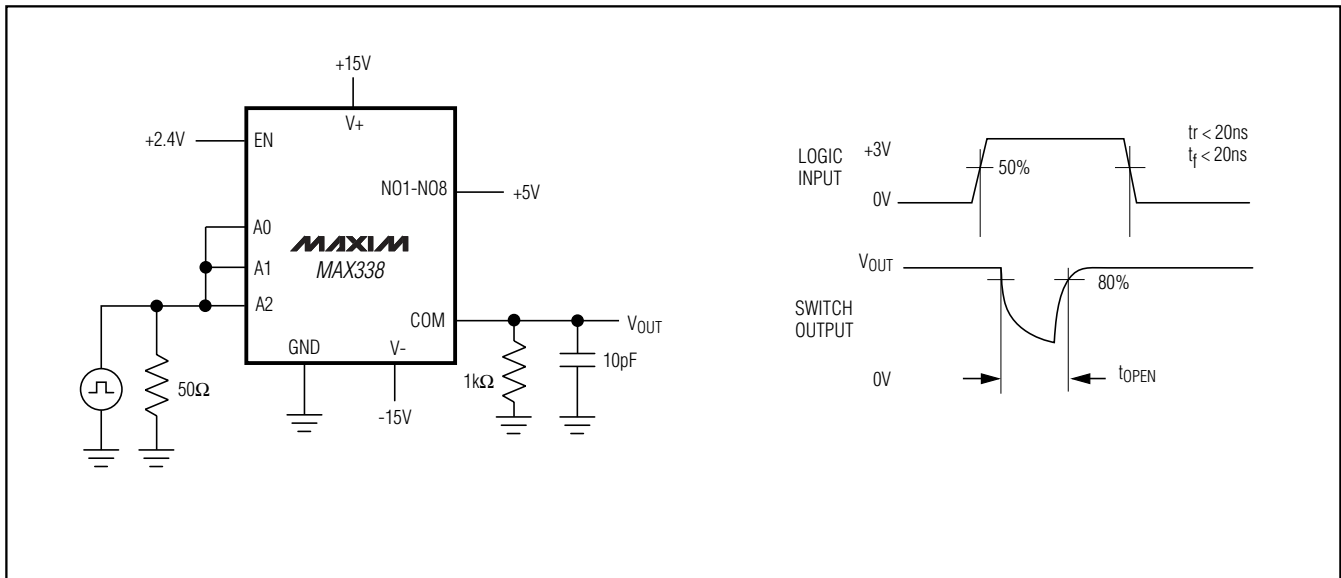

Figure 4. Break-Before-Make Interval

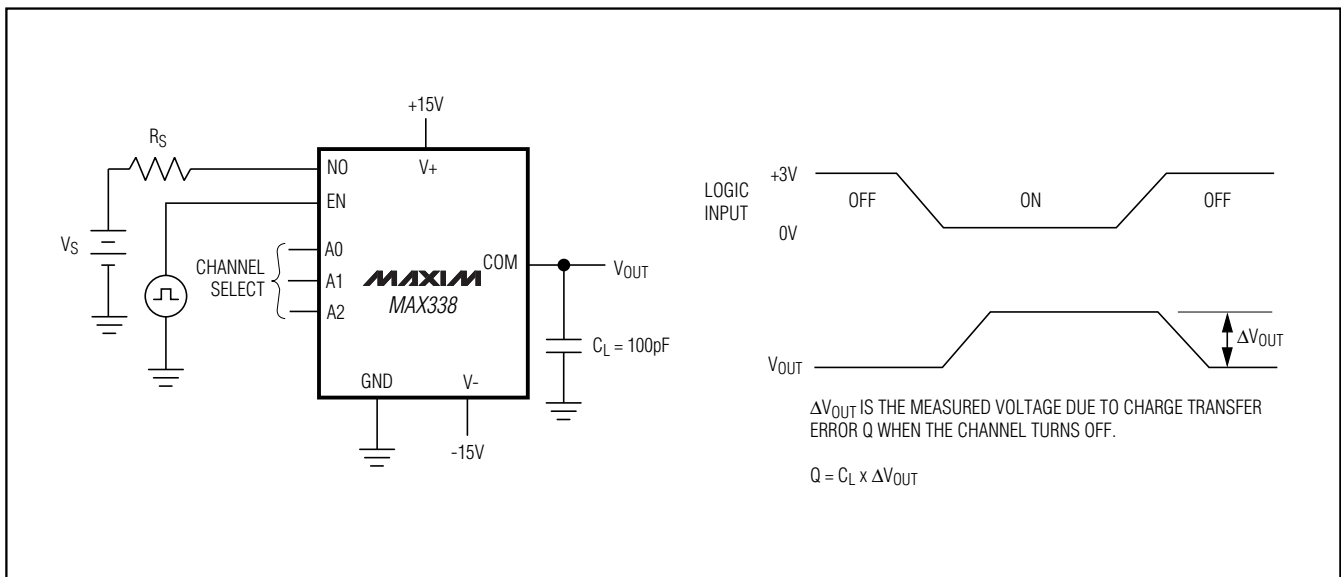

Figure 5. Charge Injection

# 8-Channel/Dual 4-Channel, Low-Leakage, CMOS Analog Multiplexers

## Test Circuits/Timing Diagrams (continued)

MAX3338/MAX3339

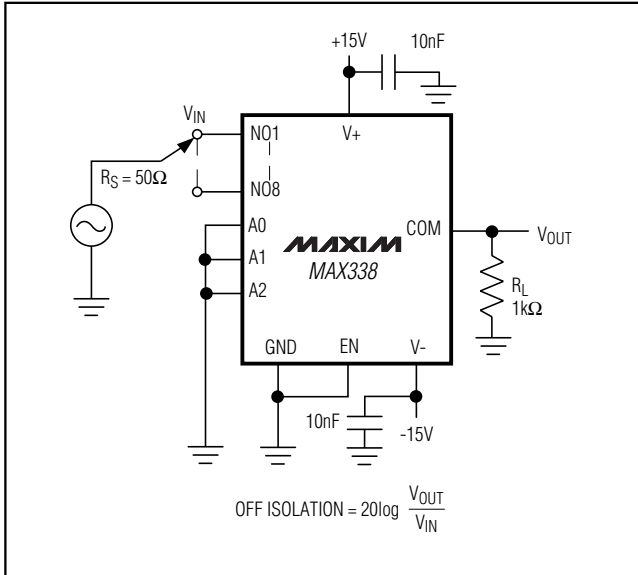

Figure 6. Off-Isolation

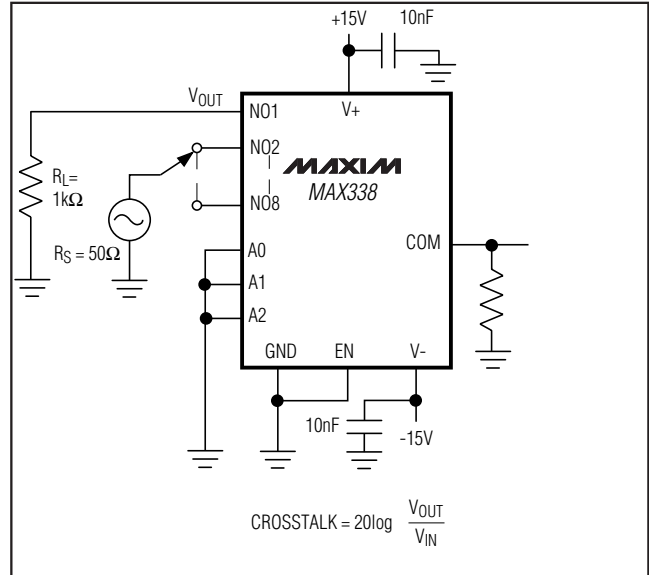

Figure 7. Crosstalk

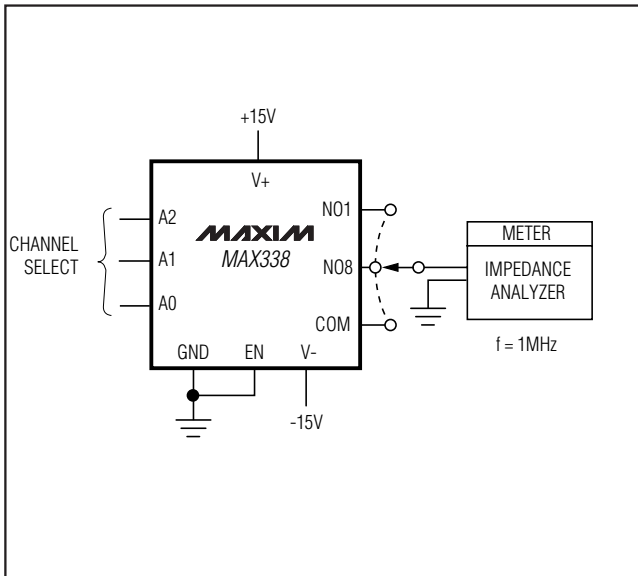
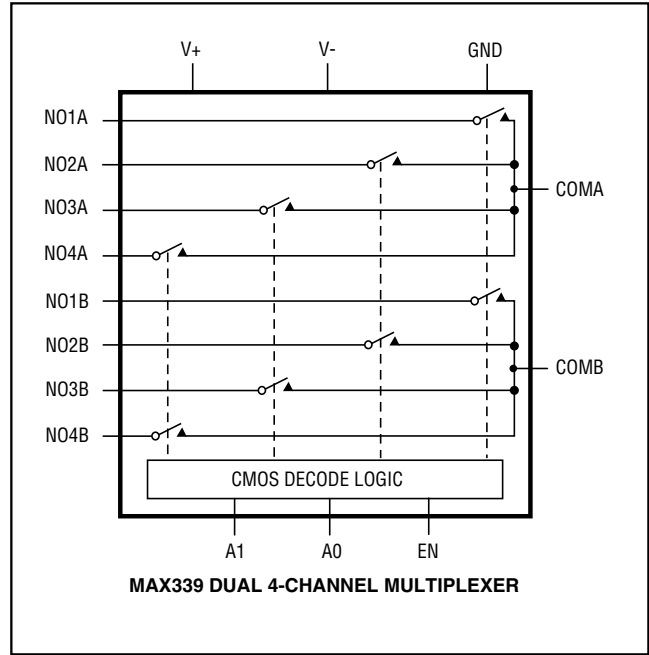
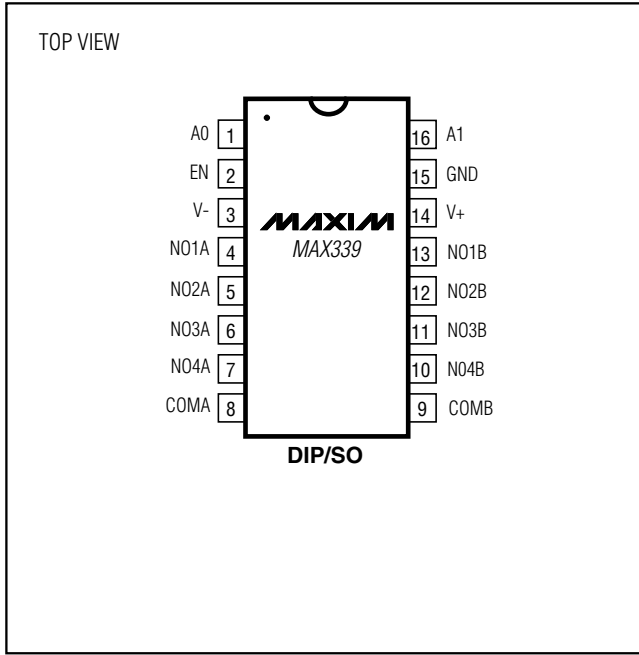

Figure 8. NO/COM Capacitance

# 8-Channel/Dual 4-Channel, Low-Leakage, CMOS Analog Multiplexers

## Pin Configurations/Functional Diagrams/Truth Tables (continued)



A2	A1	A0	EN	ON SWITCH
X	X	X	0	None
0	0	0	1	1
0	0	1	1	2
0	1	0	1	3
0	1	1	1	4
1	0	0	1	5
1	0	1	1	6
1	1	0	1	7
1	1	1	1	8

**MAX338**

LOGIC "0"  $V_{AL} \leq 0.8V$ , LOGIC "1"  $V_{AH} \geq 2.4V$

A1	A0	EN	ON SWITCH
X	X	0	None
0	0	1	1
0	1	1	2
1	0	1	3
1	1	1	4

**MAX339**

LOGIC "0"  $V_{AL} \leq 0.8V$ , LOGIC "1"  $V_{AH} \geq 2.4V$

# 8-Channel/Dual 4-Channel, Low-Leakage, CMOS Analog Multiplexers

**MAX3338/MAX3339**

## Ordering Information (continued)

PART	TEMP RANGE	PIN-PACKAGE
MAX339CPE	0°C to +70°C	16 Plastic DIP
MAX339CSE	0°C to +70°C	16 Narrow SO
MAX339C/D	0°C to +70°C	Dice*
MAX339ETE	-40°C to +85°C	16 Thin QFN (5mm x 5mm)
MAX339EPE	-40°C to +85°C	16 Plastic DIP
MAX339ESE	-40°C to +85°C	16 Narrow SO
MAX339EJE	-40°C to +85°C	16 CERDIP
MAX339MJE	-55°C to +125°C	16 CERDIP**

\*Contact factory for dice specifications.

\*\*Contact factory for availability.

## Pin Configurations/Functional Diagrams/Truth Tables (continued)

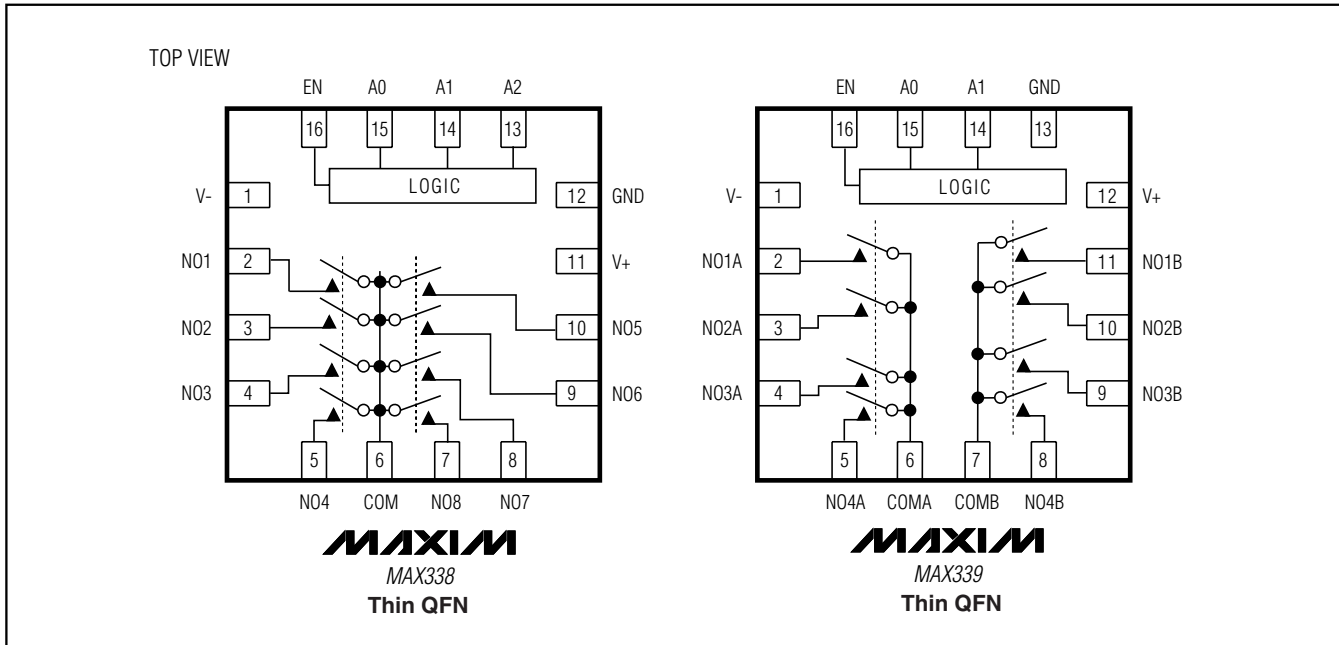

# 8-Channel/Dual 4-Channel, Low-Leakage, CMOS Analog Multiplexers

## Chip Topographies

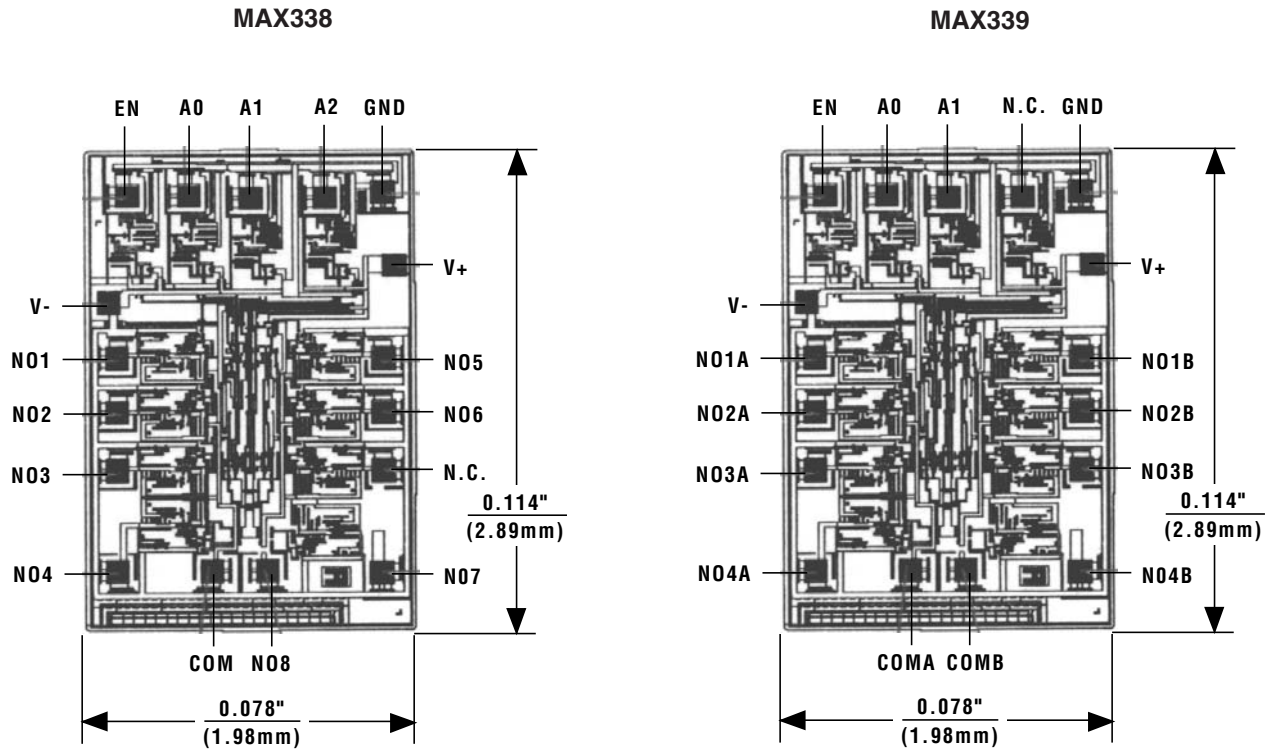

N.C. = NO INTERNAL CONNECTION

TRANSISTOR COUNT: 224  
 SUBSTRATE IS INTERNALLY CONNECTED TO V+  
**Note:** On Thin QFN packages connect exposed pad to V+.

TRANSISTOR COUNT: 224  
 SUBSTRATE IS INTERNALLY CONNECTED TO V+

# 8-Channel/Dual 4-Channel, Low-Leakage, CMOS Analog Multiplexers

## Package Information

(The package drawing(s) in this data sheet may not reflect the most current specifications. For the latest package outline information, go to [www.maxim-ic.com/packages](http://www.maxim-ic.com/packages).)

MAX3338/MAX3339

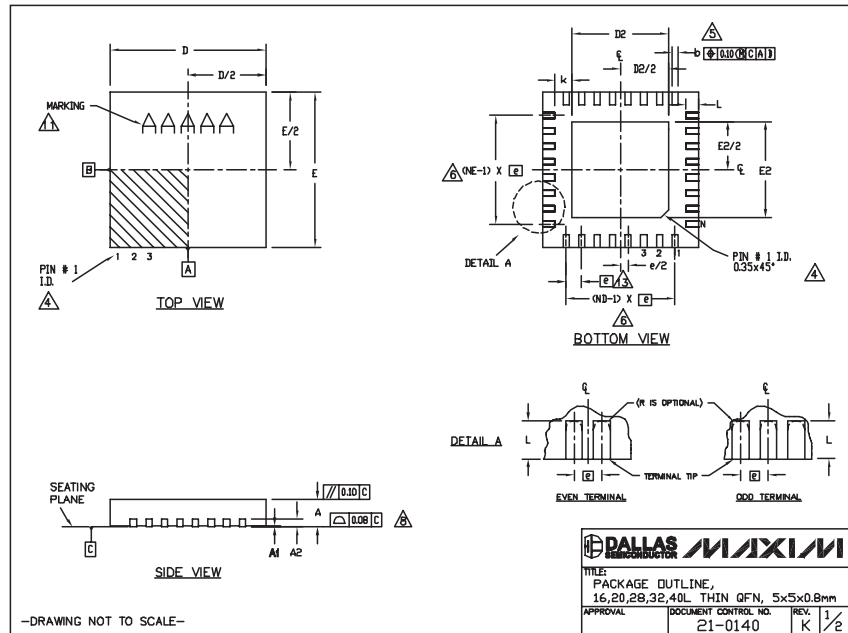

COMMON DIMENSIONS															
PKG SYMBOL	16L 5x5			20L 5x5			28L 5x5			32L 5x5			40L 5x5		
	MIN.	NOM.	MAX.	MIN.	NOM.	MAX.	MIN.	NOM.	MAX.	MIN.	NOM.	MAX.	MIN.	NOM.	MAX.
A	0.70	0.75	0.80	0.70	0.75	0.80	0.70	0.75	0.80	0.70	0.75	0.80	0.70	0.75	0.80
A1	0	0.02	0.05	0	0.02	0.05	0	0.02	0.05	0	0.02	0.05	0	0.02	0.05
A2	0.20 REF.			0.20 REF.			0.20 REF.			0.20 REF.			0.20 REF.		
b	0.25	0.30	0.35	0.25	0.30	0.35	0.20	0.25	0.30	0.20	0.25	0.30	0.15	0.20	0.25
D	4.90	5.00	5.10	4.90	5.00	5.10	4.90	5.00	5.10	4.90	5.00	5.10	4.90	5.00	5.10
E	4.90	5.00	5.10	4.90	5.00	5.10	4.90	5.00	5.10	4.90	5.00	5.10	4.90	5.00	5.10
e	0.80 BSC.			0.65 BSC.			0.50 BSC.			0.50 BSC.			0.40 BSC.		
k	0.25			0.25			0.25			0.25			0.25		
L	0.30	0.40	0.50	0.45	0.55	0.65	0.45	0.55	0.65	0.30	0.40	0.50	0.30	0.40	0.50
N	16			20			28			32			40		
ND	4			5			7			8			10		
NE	4			5			7			8			10		
JEDEC	WHHB			WHHC			WHHD-1			WHHD-2			-----		

EXPOSED PAD VARIATIONS												
PKG CODES	DP			E2								
	MIN.	NOM.	MAX.	MIN.	NOM.	MAX.						
T1655-2	3.00	3.10	3.20	3.00	3.10	3.20						
T1655-3	3.00	3.10	3.20	3.00	3.10	3.20						
T1655N-1	3.00	3.10	3.20	3.00	3.10	3.20						
T2055-3	3.00	3.10	3.20	3.00	3.10	3.20						
T2055-4	3.00	3.10	3.20	3.00	3.10	3.20						
T2055-5	3.15	3.25	3.35	3.15	3.25	3.35						
T2055N-5	3.15	3.25	3.35	3.15	3.25	3.35						
T2855-3	3.15	3.25	3.35	3.15	3.25	3.35						
T2855-4	2.60	2.70	2.80	2.60	2.70	2.80						
T2855-5	2.60	2.70	2.80	2.60	2.70	2.80						
T2855-6	3.15	3.25	3.35	3.15	3.25	3.35						
T2855-7	2.60	2.70	2.80	2.60	2.70	2.80						
T2855-9	3.15	3.25	3.35	3.15	3.25	3.35						
T2855N-1	3.15	3.25	3.35	3.15	3.25	3.35						
T3255-3	3.00	3.10	3.20	3.00	3.10	3.20						
T3255-4	3.00	3.10	3.20	3.00	3.10	3.20						
T3255N-4	3.00	3.10	3.20	3.00	3.10	3.20						
T3255-5	3.00	3.10	3.20	3.00	3.10	3.20						
T3255N-1	3.00	3.10	3.20	3.00	3.10	3.20						
T4055-1	3.40	3.50	3.60	3.40	3.50	3.60						
T4055-2	3.40	3.50	3.60	3.40	3.50	3.60						

NOTES:

- DIMENSIONING & TOLERANCING CONFORM TO ASME Y14.5M-1994.
- ALL DIMENSIONS ARE IN MILLIMETERS. ANGLES ARE IN DEGREES.
- N IS THE TOTAL NUMBER OF TERMINALS.
- THE TERMINAL #1 IDENTIFIER AND TERMINAL NUMBERING CONVENTION SHALL CONFORM TO JEDEC 95-1 SPP-012. DETAILS OF TERMINAL #1 IDENTIFIER ARE OPTIONAL, BUT MUST BE LOCATED WITHIN THE ZONE INDICATED. THE TERMINAL #1 IDENTIFIER MAY BE EITHER A MOLD OR MARKED FEATURE.
- DIMENSION b APPLIES TO METALLIZED TERMINAL AND IS MEASURED BETWEEN 0.25 mm AND 0.30 mm FROM TERMINAL TIP.
- ND AND NE REFER TO THE NUMBER OF TERMINALS ON EACH D AND E SIDE RESPECTIVELY.
- DEPOPULATION IS POSSIBLE IN A SYMMETRICAL FASHION.
- COPLANARITY APPLIES TO THE EXPOSED HEAT SINK SLUG AS WELL AS THE TERMINALS.
- DRAWING CONFORMS TO JEDEC M02B, EXCEPT EXPOSED PAD DIMENSION FOR T2855-3, T2855-6, T4055-1 AND T4055-2.
- VARPAGE SHALL NOT EXCEED 0.10 mm.
- MARKING IS FOR PACKAGE ORIENTATION REFERENCE ONLY.
- NUMBER OF LEADS SHOWN ARE FOR REFERENCE ONLY.
- LEAD CENTERLINES TO BE AT TRUE POSITION AS DEFINED BY BASIC DIMENSION 'e', #005.

Maxim cannot assume responsibility for use of any circuitry other than circuitry entirely embodied in a Maxim product. No circuit patent licenses are implied. Maxim reserves the right to change the circuitry and specifications without notice at any time.

Maxim Integrated Products, 120 San Gabriel Drive, Sunnyvale, CA 94086 408-737-7600 13

SITE  
SEARCHPART NO.  
SEARCH

WHAT'S NEW

PRODUCTS

SOLUTIONS

DESIGN

APPNOTES

SUPPORT

BUY

COMPANY

MEMBERS

## MAX338

### Part Number Table

**Notes:**

1. See the [MAX338 QuickView Data Sheet](#) for further information on this product family or download the [MAX338 full data sheet](#) (PDF, 256kB).
2. Other options and links for purchasing parts are listed at: <http://www.maxim-ic.com/sales>.
3. [Didn't Find What You Need?](#) Ask our applications engineers. Expert assistance in finding parts, usually within one business day.
4. Part number suffixes: T or T&R = tape and reel; + = RoHS/lead-free; # = RoHS/lead-exempt. More: See [full data sheet](#) or [Part Naming Conventions](#).
5. \* Some packages have variations, listed on the drawing. "PkgCode/Variation" tells which variation the product uses.

Part Number	Free Sample	Buy Direct	Package: TYPE PINS SIZE DRAWING CODE/VAR *	Temp	RoHS/Lead-Free? Materials Analysis
MAX338EJE	<input type="checkbox"/>	<input type="checkbox"/>	Ceramic DIP;16 pin;.300" Dwg: <a href="#">21-0045A</a> (PDF) Use pkgcode/variation: J16-4*	-40C to +85C	RoHS/Lead-Free: <a href="#">No Materials Analysis</a>
MAX338MJE	<input type="checkbox"/>	<input type="checkbox"/>	Ceramic DIP;16 pin;.300" Dwg: <a href="#">21-0045A</a> (PDF) Use pkgcode/variation: J16-4*	-55C to +125C	RoHS/Lead-Free: <a href="#">No Materials Analysis</a>
MAX338C/D	<input type="checkbox"/>	<input type="checkbox"/>			RoHS/Lead-Free: <a href="#">No</a>
MAX338CPE	<input type="checkbox"/>	<input type="checkbox"/>	PDIP;16 pin;.300" Dwg: <a href="#">21-0043D</a> (PDF) Use pkgcode/variation: P16-1*	0C to +70C	RoHS/Lead-Free: <a href="#">No Materials Analysis</a>
MAX338CPE+	<input type="checkbox"/>	<input type="checkbox"/>	PDIP;16 pin;.300" Dwg: <a href="#">21-0043D</a> (PDF) Use pkgcode/variation: P16+1*	0C to +70C	RoHS/Lead-Free: <a href="#">Yes Materials Analysis</a>
MAX338EPE+	<input type="checkbox"/>	<input type="checkbox"/>	PDIP;16 pin;.300" Dwg: <a href="#">21-0043D</a> (PDF) Use pkgcode/variation: P16+1*	-40C to +85C	RoHS/Lead-Free: <a href="#">Yes Materials Analysis</a>
MAX338EPE	<input type="checkbox"/>	<input type="checkbox"/>	PDIP;16 pin;.300" Dwg: <a href="#">21-0043D</a> (PDF) Use pkgcode/variation: P16-1*	-40C to +85C	RoHS/Lead-Free: <a href="#">No Materials Analysis</a>

MAX338EEE+			QSOP;16 pin;.150" Dwg: <a href="#">21-0055F</a> (PDF) Use pkgcode/variation: E16+6*	-40C to +85C	RoHS/Lead-Free: <a href="#">Yes</a> <a href="#">Materials Analysis</a>
MAX338EEE+T				-40C to +85C	RoHS/Lead-Free: <a href="#">Yes</a>
MAX338CEE+T				0C to +70C	RoHS/Lead-Free: <a href="#">Yes</a>
MAX338CEE+			QSOP;16 pin;.150" Dwg: <a href="#">21-0055F</a> (PDF) Use pkgcode/variation: E16+6*	0C to +70C	RoHS/Lead-Free: <a href="#">Yes</a> <a href="#">Materials Analysis</a>
MAX338CEE			QSOP;16 pin;.150" Dwg: <a href="#">21-0055F</a> (PDF) Use pkgcode/variation: E16-6*	0C to +70C	RoHS/Lead-Free: <a href="#">No</a> <a href="#">Materials Analysis</a>
MAX338CEE-T			QSOP;16 pin;.150" Dwg: <a href="#">21-0055F</a> (PDF) Use pkgcode/variation: E16-6*	0C to +70C	RoHS/Lead-Free: <a href="#">No</a> <a href="#">Materials Analysis</a>
MAX338EEE-T			QSOP;16 pin;.150" Dwg: <a href="#">21-0055F</a> (PDF) Use pkgcode/variation: E16-6*	-40C to +85C	RoHS/Lead-Free: <a href="#">No</a> <a href="#">Materials Analysis</a>
MAX338EEE			QSOP;16 pin;.150" Dwg: <a href="#">21-0055F</a> (PDF) Use pkgcode/variation: E16-6*	-40C to +85C	RoHS/Lead-Free: <a href="#">No</a> <a href="#">Materials Analysis</a>
MAX338CSE			SOIC;16 pin;.150" Dwg: <a href="#">21-0041B</a> (PDF) Use pkgcode/variation: S16-2*	0C to +70C	RoHS/Lead-Free: <a href="#">No</a> <a href="#">Materials Analysis</a>
MAX338CSE+T			SOIC;16 pin;.150" Dwg: <a href="#">21-0041B</a> (PDF) Use pkgcode/variation: S16+2*	0C to +70C	RoHS/Lead-Free: <a href="#">Yes</a> <a href="#">Materials Analysis</a>
MAX338CSE+			SOIC;16 pin;.150" Dwg: <a href="#">21-0041B</a> (PDF) Use pkgcode/variation: S16+2*	0C to +70C	RoHS/Lead-Free: <a href="#">Yes</a> <a href="#">Materials Analysis</a>
MAX338CSE-T			SOIC;16 pin;.150" Dwg: <a href="#">21-0041B</a> (PDF) Use pkgcode/variation: S16-2*	0C to +70C	RoHS/Lead-Free: <a href="#">No</a> <a href="#">Materials Analysis</a>
MAX338ESE+T			SOIC;16 pin;.150" Dwg: <a href="#">21-0041B</a> (PDF) Use pkgcode/variation: S16+2*	-40C to +85C	RoHS/Lead-Free: <a href="#">Yes</a> <a href="#">Materials Analysis</a>
MAX338ESE+			SOIC;16 pin;.150" Dwg: <a href="#">21-0041B</a> (PDF) Use pkgcode/variation: S16+2*	-40C to +85C	RoHS/Lead-Free: <a href="#">Yes</a> <a href="#">Materials Analysis</a>
MAX338ESE-T			SOIC;16 pin;.150" Dwg: <a href="#">21-0041B</a> (PDF) Use pkgcode/variation: S16-2*	-40C to +85C	RoHS/Lead-Free: <a href="#">No</a> <a href="#">Materials Analysis</a>
MAX338ESE			SOIC;16 pin;.150" Dwg: <a href="#">21-0041B</a> (PDF) Use pkgcode/variation: S16-2*	-40C to +85C	RoHS/Lead-Free: <a href="#">No</a> <a href="#">Materials Analysis</a>

MAX338ETE			THIN QFN;16 pin;5x5x0.8mm Dwg: <a href="#">21-0140K</a> (PDF) Use pkgcode/variation: T1655-2*	-40C to +85C	RoHS/Lead-Free: <a href="#">No</a> <a href="#">Materials Analysis</a>
MAX338ETE-T				-40C to +85C	RoHS/Lead-Free: <a href="#">No</a>
MAX338ETE+			THIN QFN;16 pin;5x5x0.8mm Dwg: <a href="#">21-0140K</a> (PDF) Use pkgcode/variation: T1655+2*	-40C to +85C	RoHS/Lead-Free: <a href="#">Yes</a> <a href="#">Materials Analysis</a>
MAX338ETE+T				-40C to +85C	RoHS/Lead-Free: <a href="#">Yes</a>

[Didn't Find What You Need?](#)

[CONTACT US: SEND US AN EMAIL](#)