



+5V, Fail-Safe, 20Mbps, Profibus RS-485/ RS-422 Transceivers

MAX3460-MAX3464

General Description

The MAX3460–MAX3464 are high-speed differential bus transceivers for RS-485 and RS-422 communications. They are designed to meet TIA/EIA-422-B, TIA/EIA-485-A, V.11, and X.27 standards. The transceiver complies with the Profibus specification providing +2.1V output level with a 54Ω load, 20Mbps data rate, and output skew less than 2ns. Each part contains one three-state differential line driver and one differential input line receiver. The devices operate from a +5V supply and feature true fail-safe circuitry, which guarantees a logic-high receiver output when the receiver inputs are open or shorted. This enables all receiver outputs on a terminated bus to output logic highs when all transmitters are disabled.

All devices feature a 1/4 standard unit load receiver input impedance that allows 128 transceivers on the bus. Driver and receiver propagation delays are guaranteed under 20ns for multidrop, clock distribution applications. Drivers are short-circuit current limited and are protected against excessive power dissipation by thermal shutdown circuitry. The driver and receiver feature active-high and active-low enables, respectively, that can be connected together externally to serve as a direction control.

Applications

High-Speed RS-485 Communications
High-Speed RS-422 Communications
Level Translators
Industrial-Control Local Area Networks
Profibus Applications

Features

- ◆ Recommended for Profibus Applications
- ◆ Guaranteed 20Mbps Data Rate
- ◆ 20ns Transmitter and Receiver Propagation Delay
- ◆ 2ns Transmitter and Receiver Skew
- ◆ High Differential Driver Output Level (2.1V on 54Ω)
- ◆ Hot-Swap Versions
- ◆ 1μA Shutdown Supply Current
- ◆ Low Supply Current Requirements (2.5mA typ)
- ◆ Allow Up to 128 Transceivers on the Bus
- ◆ True Fail-Safe Receiver while Maintaining EIA/TIA-485 Compatibility
- ◆ Designed for Multipoint Transmissions on Long or Noisy Bus Lines
- ◆ Full Duplex and Half Duplex Versions Available
- ◆ Phase Controls to Correct for Twisted-Pair Reversal for 14-Pin Versions
- ◆ Current-Limiting and Thermal Shutdown for Driver Overload Protection

Ordering Information

PART	TEMP RANGE	PIN-PACKAGE
MAX3460CSD	0°C to +70°C	14 SO
MAX3460CPD	0°C to +70°C	14 Plastic DIP
MAX3460ESD	-40°C to +85°C	14 SO
MAX3460EPD	-40°C to +85°C	14 Plastic DIP

Ordering Information continued at end of data sheet.

Pin Configurations appear at end of data sheet.

Selector Guide

PART NUMBER	HALF/FULL DUPLEX	RECEIVER/DRIVER ENABLE	LOW-POWER SHUTDOWN	HOT SWAP	RECEIVER/DRIVER PHASE SELECT	INDEPENDENT SHDN PIN	PIN COUNT
MAX3460	Full	Yes	Yes	Yes	Yes	Yes	14
MAX3461	Full	Yes	Yes	No	Yes	Yes	14
MAX3462	Full	No	No	No	No	No	8
MAX3463	Half	Yes	Yes	Yes	No	No	8
MAX3464	Half	Yes	Yes	No	No	No	8



+5V, Fail-Safe, 20Mbps, Profibus RS-485/ RS-422 Transceivers

ABSOLUTE MAXIMUM RATINGS

Supply Voltage (V_{CC}) to GND	-0.3V to +6V	Continuous Power Dissipation ($T_A = +70^\circ\text{C}$)
Control Input Voltage (\overline{RE} , DE, DI, SHDN, TXP, RXP) to GND.....	-0.3V to ($V_{CC} + 0.3V$)	8-Pin SO (derate 5.88mW/ $^\circ\text{C}$ above $+70^\circ\text{C}$).....
Driver Output Voltage (Y, Z) to GND.....	-8V to +13V	8-Pin DIP (derate 9.09mW/ $^\circ\text{C}$ above $+70^\circ\text{C}$).....
Receiver Input Voltage (A, B) to GND.....	-8V to +13V	14-Pin SO (derate 8.33mW/ $^\circ\text{C}$ above $+70^\circ\text{C}$).....
Differential Driver Output Voltage (Y - Z).....	$\pm 8V$	14-Pin DIP (derate 10mW/ $^\circ\text{C}$ above $+70^\circ\text{C}$).....
Differential Receiver Input (A - B).....	$\pm 8V$	Operating Temperature Range
Receiver Output Voltage (RO).....	-0.3V to ($V_{CC} + 0.3V$)	MAX346_C_.....
Output Driver Current (Y, Z)	$\pm 250\text{mA}$	MAX346_E_.....
		Junction Temperature
		Storage Temperature Range
		Lead Temperature (soldering, 10s)

Stresses beyond those listed under "Absolute Maximum Ratings" may cause permanent damage to the device. These are stress ratings only, and functional operation of the device at these or any other conditions beyond those indicated in the operational sections of the specifications is not implied. Exposure to absolute maximum rating conditions for extended periods may affect device reliability.

ELECTRICAL CHARACTERISTICS

($V_{CC} = +5V \pm 5\%$, $T_A = T_{MIN}$ to T_{MAX} , unless otherwise noted. Typical values are at $V_{CC} = +5V$ and $T_A = +25^\circ\text{C}$.) (Note 1)

PARAMETER	SYMBOL	CONDITIONS	MIN	TYP	MAX	UNITS	
Power-Supply Range	V_{CC}		4.75		5.25	V	
DRIVER							
Differential Driver Output (no load)	V_{OD}	Figure 5, $R = \infty$			V_{CC}	V	
Differential Driver Output	V_{OD}	Figure 5, $R = 27\Omega$	2.1			V	
Change in Magnitude of Differential Output Voltage	ΔV_{OD}	Figure 5, $R = 50\Omega$ or 27Ω (Note 2)			0.2	V	
Driver Common-Mode Output Voltage	V_{OC}	Figure 5, $R = 50\Omega$ or 27Ω			3	V	
Change in Magnitude of Common-Mode Voltage	ΔV_{OC}	Figure 5, $R = 50\Omega$ or 27Ω (Note 2)			0.2	V	
Input High Voltage	V_{IH}	DE, DI, \overline{RE} , SHDN	2.0			V	
Input Low Voltage	V_{IL}	DE, DI, \overline{RE} , SHDN			0.8	V	
Input Hysteresis	V_{HYS}	DE, DI, \overline{RE} , SHDN		50		mV	
Output Leakage (Y and Z) Full Duplex	I_O	DE = GND, $V_{CC} =$ GND or +5.25V	$V_{IN} = +12V$ $V_{IN} = -7V$		+125	μA	
Input Current	I_{IN}	DI, \overline{RE} , DE, SHDN			± 1	μA	
Pulldown Current		RXP = TXP = V_{CC}	5	15	30	μA	
Driver Short-Circuit Output Current (Note 3)	I_{OSD}	$0 \leq V_{OUT} \leq 12V$, output low $-7V \leq V_{OUT} \leq V_{CC}$, output high			+250	mA	
Driver Short-Circuit Foldback Output Current (Note 3)	I_{OSFD}	$(V_{CC} - 1V) \leq V_{OUT} \leq 12V$, output low $-7V \leq V_{OUT} \leq 1V$, output high	+25		-25	mA	
Thermal Shutdown Threshold				140		$^\circ\text{C}$	
RECEIVER							
Differential Input Capacitance	$C_{A, B}$			8		pF	
Input Current (A and B) Full Duplex	$I_{A, B}$	DE = GND, $V_{CC} =$ GND or 5.25V	$V_{IN} = +12V$ $V_{IN} = -7V$		250	μA	
Receiver Differential Threshold Voltage	V_{TH}	$-7V \leq V_{CM} \leq 12V$		-200	-125	-50	mV

+5V, Fail-Safe, 20Mbps, Profibus RS-485/ RS-422 Transceivers

MAX3460-MAX3464

ELECTRICAL CHARACTERISTICS (continued)

($V_{CC} = +5V \pm 5\%$, $T_A = T_{MIN}$ to T_{MAX} , unless otherwise noted. Typical values are at $V_{CC} = +5V$ and $T_A = +25^\circ C$.) (Note 1)

PARAMETER	SYMBOL	CONDITIONS	MIN	TYP	MAX	UNITS
Receiver Input Hysteresis	ΔV_{TH}	$V_A + V_B = 0$		20		mV
Receiver Output High Voltage	V_{OH}	$I_O = -4mA$, $V_A - V_B = V_{TH}$	$V_{CC} - 1.5$			V
Receiver Output Low Voltage	V_{OL}	$I_O = 4mA$, $V_B - V_A = V_{TH}$			0.4	V
Three-State Output Current at Receiver	I_{OZR}	$0 \leq V_O \leq V_{CC}$			± 1	μA
Receiver Input Resistance	R_{IN}	$-7V \leq V_{CM} \leq 12V$	48			$k\Omega$
Receiver Output Short-Circuit Current	I_{OSR}	$0 \leq V_{RO} \leq V_{CC}$	± 7		± 95	mA
SUPPLY CURRENT						
Normal Operation (static condition)	I_Q	No load, $DI = V_{CC}$ or $DI = GND$		2.5	4	mA
Supply Current in SHDN	I_{SHDN}	$DE = GND$ and $\overline{RE} = V_{CC}$, or $SHDN = V_{CC}$		1	10	μA
SWITCHING CHARACTERISTICS						
Driver Propagation Delay	t_{PLH}	Figures 6 and 7, $R_{DIFF} = 54\Omega$, $C_L = 50pF$			20	ns
	t_{PHL}					
Driver Differential Output Rise or Fall Time	t_R	Figures 6 and 7, $R_{DIFF} = 54\Omega$, $C_L = 50pF$			20	ns
	t_F					
Driver Output Skew $ t_{PLH} - t_{PHL} $	t_{SKEW}	Figures 6 and 7, $R_{DIFF} = 54\Omega$, $C_L = 50pF$, $TXP = GND$ or floating			2	ns
Maximum Data Rate			20			Mbps
Driver Enable to Output High	t_{ZH}	Figures 8 and 9, S_2 closed, $R_L = 500\Omega$, $C_L = 50pF$			100	ns
Driver Enable to Output Low	t_{ZL}	Figures 8 and 9, S_1 closed, $R_L = 500\Omega$, $C_L = 50pF$			100	ns
Driver Disable Time from Low	t_{LZ}	Figures 8 and 9, S_1 closed, $R_L = 500\Omega$, $C_L = 50pF$			100	ns
Driver Disable Time from High	t_{HZ}	Figures 8 and 9, S_2 closed, $R_L = 500\Omega$, $C_L = 50pF$			100	ns
Receiver Propagation Delay	t_{PLH}	Figure 10, $C_L = 15pF$ (Note 4)			20	ns
	t_{PHL}					
Receiver Output Skew $ t_{PLH} - t_{PHL} $	t_{SKEW}	Figure 10, $C_L = 15pF$, $RXP = GND$ or floating (Note 4)			2	ns
Receiver Enable to Output Low	t_{ZL}	Figures 8 and 11, $R_L = 1k\Omega$, $C_L = 15pF$, S_1 closed (Note 4)			100	ns
Receiver Enable to Output High	t_{ZH}	Figures 8 and 11, $R_L = 1k\Omega$, $C_L = 15pF$, S_2 closed (Note 4)			100	ns
Receiver Disable Time from Low	t_{LZ}	Figures 8 and 11, $R_L = 1k\Omega$, $C_L = 15pF$, S_1 closed (Note 4)			100	ns
Receiver Disable Time from High	t_{HZ}	Figures 8 and 11, $R_L = 1k\Omega$, $C_L = 15pF$, S_2 closed (Note 4)			100	ns

+5V, Fail-Safe, 20Mbps, Profibus RS-485/ RS-422 Transceivers

ELECTRICAL CHARACTERISTICS (continued)

($V_{CC} = +5V \pm 5\%$, $T_A = T_{MIN}$ to T_{MAX} , unless otherwise noted. Typical values are at $V_{CC} = +5V$ and $T_A = +25^\circ C$.) (Note 1)

PARAMETER	SYMBOL	CONDITIONS	MIN	TYP	MAX	UNITS
Time to Shutdown	t_{SHDN}	(Note 5)	50		800	ns
Driver Enable from Shutdown to Output High	$t_{ZH} (SHDN)$	Figures 8 and 9, $R_L = 500\Omega$, $C_L = 50pF$, S2 closed (Note 5)			4	μs
Driver Enable from Shutdown to Output Low	$t_{ZL} (SHDN)$	Figures 8 and 9, $R_L = 500\Omega$, $C_L = 50pF$, S1 closed (Note 5)			4	μs
Receiver Enable from Shutdown to Output High	$t_{ZH} (SHDN)$	Figures 8 and 11, $R_L = 1k\Omega$, $C_L = 15pF$, S2 closed (Notes 4, 5)			4	μs
Receiver Enable from Shutdown to Output Low	$t_{ZL} (SHDN)$	Figures 8 and 11, $R_L = 1k\Omega$, $C_L = 15pF$, S1 closed (Notes 4, 5)			4	μs

Note 1: All currents into the device are positive; all currents out of the device are negative. All voltages are referenced to device ground, unless otherwise noted.

Note 2: ΔV_{OD} and ΔV_{OC} are the changes in V_{OD} and V_{OC} , respectively, when the DI input changes state.

Note 3: The short-circuit output current applies to peak current just prior to foldback-current limiting; the short-circuit foldback output current applies during current limiting to allow a recovery from bus contention.

Note 4: Capacitive load includes test probe and fixture capacitance.

Note 5: Shutdown is enabled by bringing \overline{RE} high and DE low or by bringing SHDN high. If the enable inputs are in this state for less than 50ns, the device is guaranteed not to enter shutdown. If the enable inputs are in this state for at least 800ns, the device is guaranteed to have entered shutdown.

Typical Operating Characteristics

($V_{CC} = +5V$, $T_A = +25^\circ C$, unless otherwise noted.)

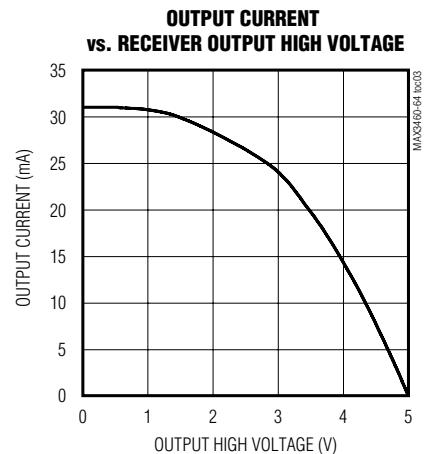
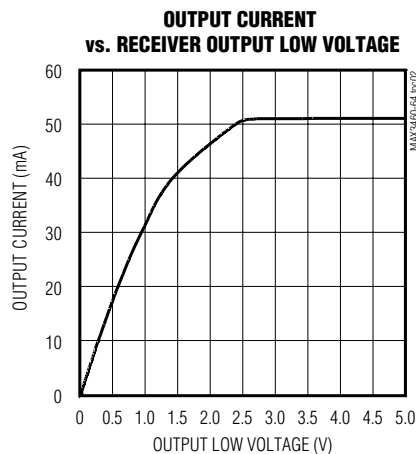
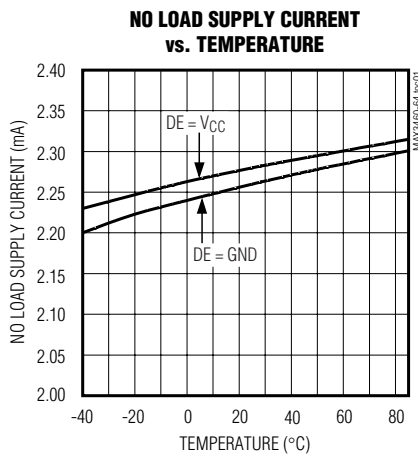

+5V, Fail-Safe, 20Mbps, Profibus RS-485/ RS-422 Transceivers

Typical Operating Characteristics (continued)

($V_{CC} = +5V$, $T_A = +25^\circ C$, unless otherwise noted.)

MAX3460-MAX3464

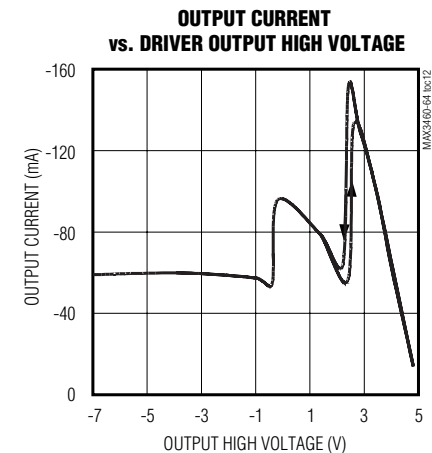
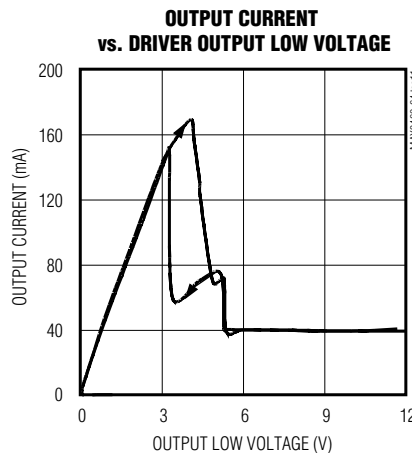
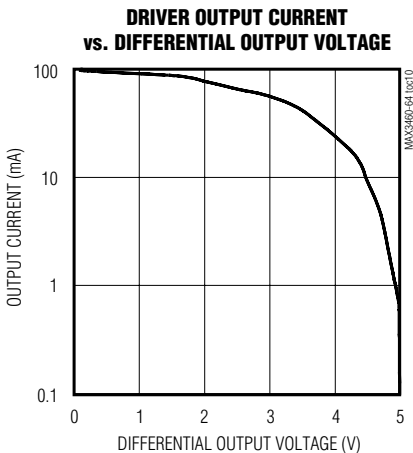
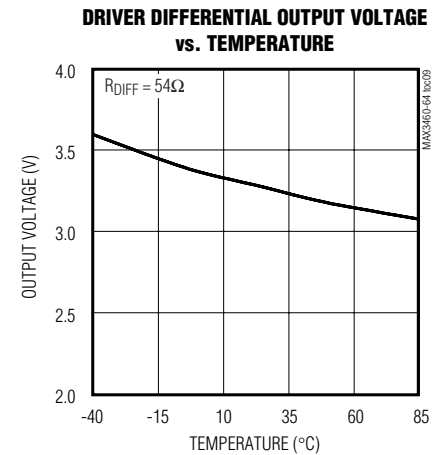
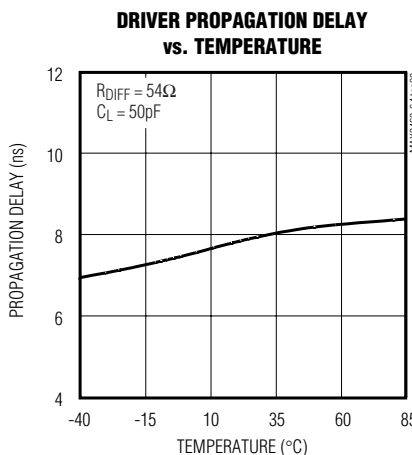
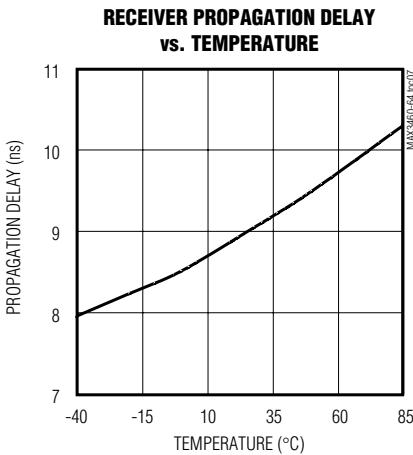
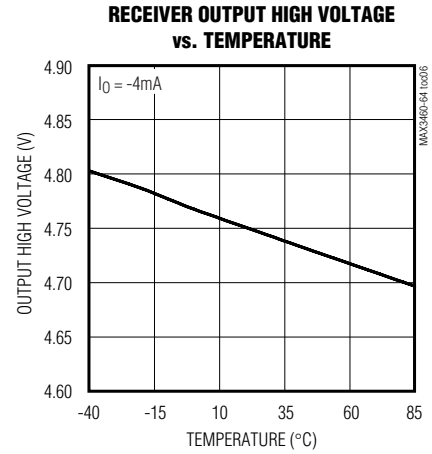
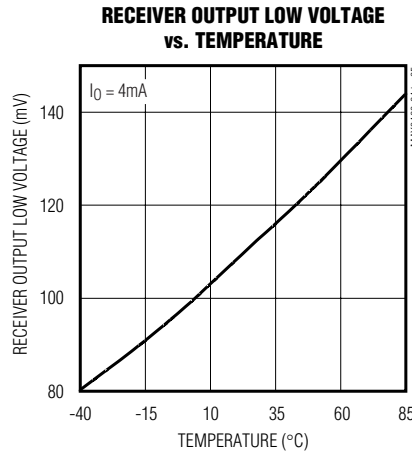
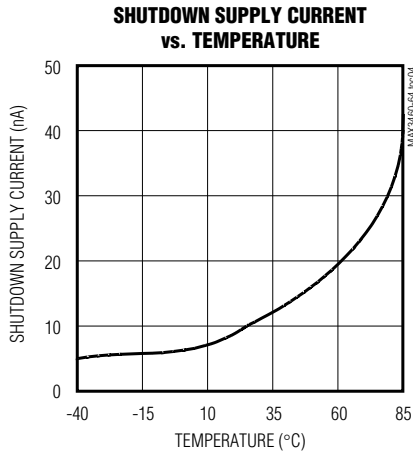

+5V, Fail-Safe, 20Mbps, Profibus RS-485/ RS-422 Transceivers

Typical Operating Characteristics (continued)

(V_{CC} = +5V, T_A = +25°C, unless otherwise noted.)

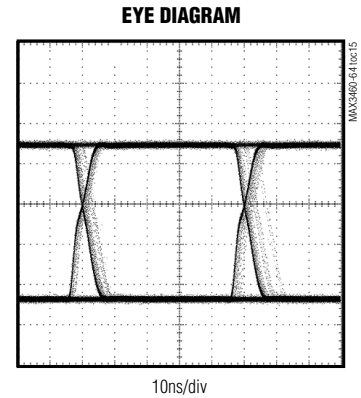
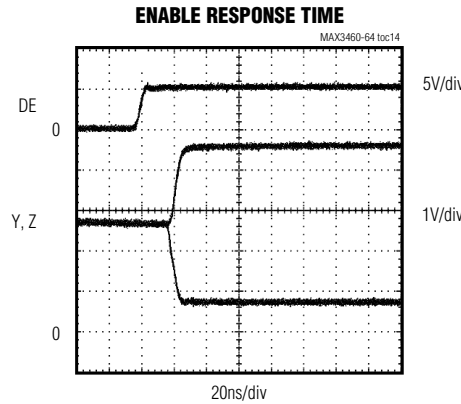
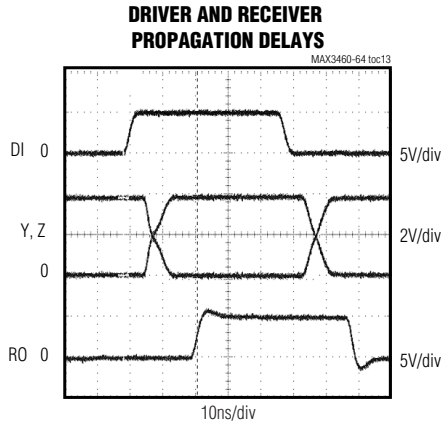

Pin Description

PIN			NAME	FUNCTION
MAX3460/ MAX3461	MAX3462	MAX3463/ MAX3464		
FULL DUPLEX		HALF DUPLEX		
1	—	—	SHDN	Shutdown. Drive SHDN high to enter low-power shutdown mode.
2	2	1	RO	Receiver Output. When \overline{RE} is low and (A - B) \geq -50mV, RO is high; if (A - B) \leq -200mV, RO is low.
3	—	2	\overline{RE}	Receiver Output Enable. Drive \overline{RE} low to enable RO; RO is high impedance when \overline{RE} is high. Drive \overline{RE} high and DE low to enter low-power shutdown mode.
4	—	3	DE	Driver Output Enable. Drive DE high to enable driver output. These outputs are high impedance when DE is low. Drive \overline{RE} high and DE low to enter low-power shutdown mode.
5	3	4	DI	Driver Input. With DE high, a low on DI forces the noninverting output low and the inverting output high. Similarly, a high on DI forces the noninverting output high and the inverting output low.
6, 7	4	5	GND	Ground
8	—	—	TXP	Transmitter Phase. Connect TXP to GND, or leave unconnected for normal transmitter phase/polarity. Connect TXP to V _{CC} to invert the transmitter phase/polarity. TXP has an internal 15 μ A pulldown.
9	5	—	Y	Noninverting Driver Output
10	6	—	Z	Inverting Driver Output
11	7	—	B	Inverting Receiver Input
12	8	—	A	Noninverting Receiver Input
13	—	—	RXP	Receiver Phase. Connect RXP to GND, or leave unconnected for normal receiver phase/polarity. Connect RXP to V _{CC} to invert the receiver phase/polarity. RXP has an internal 15 μ A pulldown.
14	1	8	V _{CC}	Positive Supply: +4.75V \leq V _{CC} \leq +5.25V. Bypass V _{CC} to GND with a 0.1 μ F capacitor.
—	—	7	B	Inverting Receiver Input and Inverting Driver Output
—	—	6	A	Noninverting Receiver Input and Noninverting Driver Output

+5V, Fail-Safe, 20Mbps, Profibus RS-485/ RS-422 Transceivers

Function Tables

MAX3460-MAX3464

MAX3460/MAX3461

TRANSMITTING					
INPUTS				OUTPUTS	
\overline{RE}	DE	DI	SHDN	Z	Y
X	1	1	0	0	1
X	1	0	0	1	0
0	0	X	0	High-Z	High-Z
1	0	X	X	Shutdown	
X	X	X	1	Shutdown	
RECEIVING					
INPUTS				OUTPUT	
\overline{RE}	DE	A-B	SHDN	RO	
0	X	$\geq -0.05V$	0	1	
0	X	$\leq -0.2V$	0	0	
0	X	Open/Shorted	0	1	
1	1	X	0	High-Z	
1	0	X	X	Shutdown	
X	X	X	1	Shutdown	

MAX3462

TRANSMITTING		
INPUT	OUTPUTS	
DI	Z	Y
1	0	1
0	1	0
RECEIVING		
INPUTS	OUTPUT	
A-B	RO	
$\geq -0.05V$	1	
$\leq -0.2V$	0	
Open/Shorted	1	

MAX3463/MAX3464

TRANSMITTING				
INPUTS			OUTPUTS	
\overline{RE}	DE	DI	B	A
X	1	1	0	1
X	1	0	1	0
0	0	X	High-Z	High-Z
1	0	X	Shutdown	
RECEIVING				
INPUTS			OUTPUT	
\overline{RE}	DE	A-B	RO	
0	X	$\geq -0.05V$	1	
0	X	$\leq -0.2V$	0	
0	X	Open/Shorted	1	
1	1	X	High-Z	
1	0	X	Shutdown	

+5V, Fail-Safe, 20Mbps, Profibus RS-485/ RS-422 Transceivers

Pin Configurations and Typical Operating Circuit

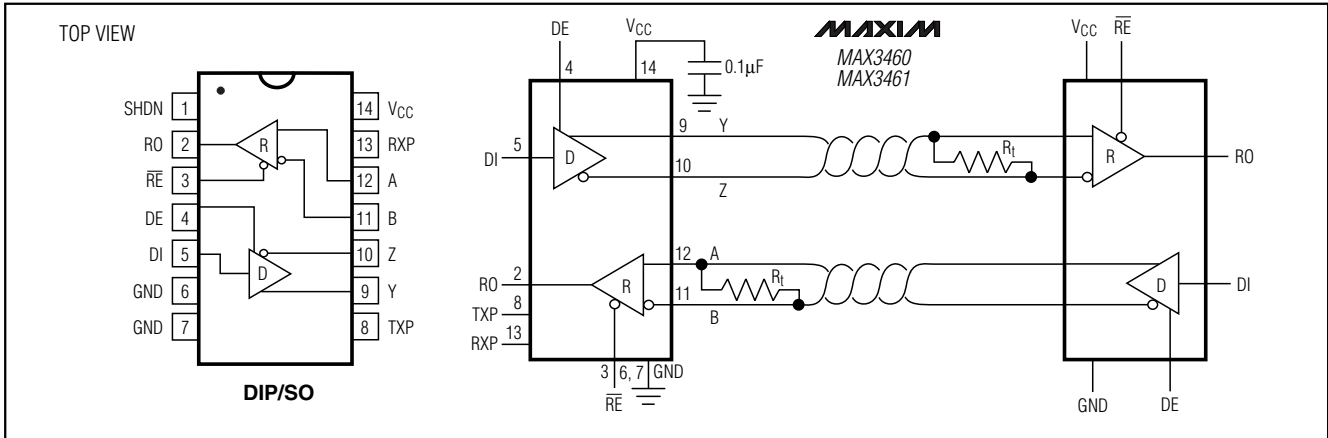

Figure 1. MAX3460/MAX3461 Pin Configuration and Typical Full-Duplex Operating Circuit

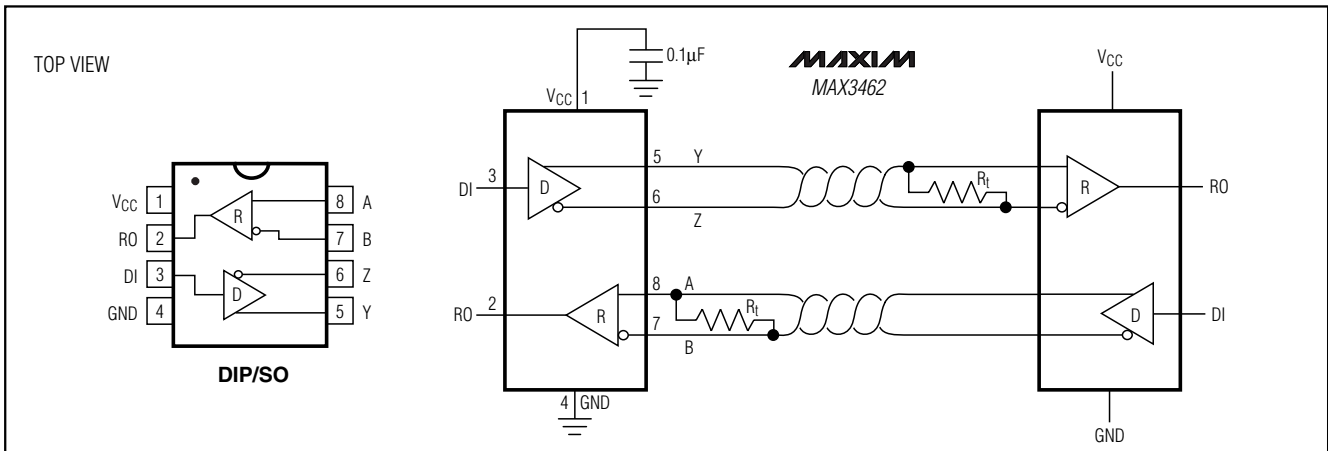

Figure 2. MAX3462 Pin Configuration and Typical Full-Duplex Operating Circuit

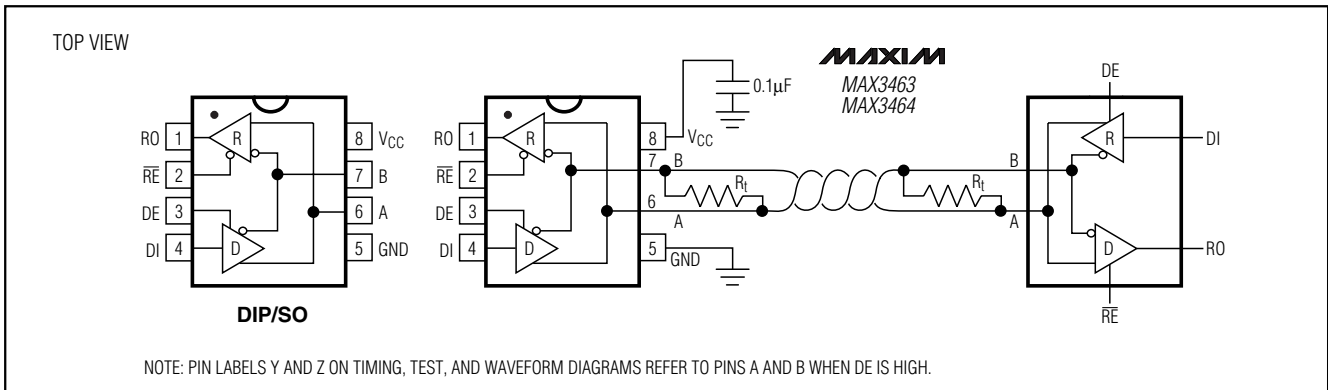

Figure 3. MAX3463/MAX3464 Pin Configuration and Typical Full-Duplex Operating Circuit

+5V, Fail-Safe, 20Mbps, Profibus RS-485/ RS-422 Transceivers

Detailed Description

The MAX3460-MAX3464 high-speed transceivers for RS-485/RS-422 communication contain one driver and one receiver. These devices feature true fail-safe circuitry, which guarantees a logic-high receiver output when the receiver inputs are open or shorted, or when they are connected to a terminated transmission line with all drivers disabled (see the *True Fail-Safe* section). The MAX3460-MAX3464's driver slew rates allow transmit speeds up to 20Mbps.

The MAX3463 and MAX3464 are half-duplex transceivers, while the MAX3460, MAX3461, and MAX3462 are full-duplex transceivers. All of these parts operate from a single +5V supply. Drivers are output short-circuit current limited. Thermal shutdown circuitry protects drivers against excessive power dissipation. When activated, the thermal shutdown circuitry places the driver outputs into a high-impedance state. The MAX3460 and MAX3463 devices have a hot-swap input structure that prevents disturbances on the differential signal lines when a circuit board is plugged into a "hot" backplane (see *Hot Swap* section). All devices have output levels that are compatible with Profibus standards.

True Fail-Safe

The MAX3460-MAX3464 guarantee a logic-high receiver output when the receiver inputs are shorted or open, or when they are connected to a terminated transmission line with all drivers disabled. This is done by setting the receiver threshold between -50mV and -200mV. If the differential receiver input voltage (A - B) is greater than or equal to -50mV, RO is logic high. If A - B is less than or equal to -200mV, RO is logic low. In the case of a terminated bus with all transmitters disabled, the receiver's differential input voltage is pulled to 0V by the termination. With the receiver thresholds of the MAX3460-MAX3464, this results in a logic high with a 50mV minimum noise margin. Unlike previous true fail-safe devices, the -50mV to -200mV threshold complies with the $\pm 200\text{mV}$ EIA/TIA-485 standard.

Hot-Swap Capability

Hot-Swap Inputs

When circuit boards are inserted into a "hot" or powered backplane, disturbances to the enable and differential receiver inputs can lead to data errors. Upon initial circuit board insertion, the processor undergoes its power-up sequence. During this period, the output drivers are high impedance and are unable to drive the DE input of the MAX3460/MAX3463 to a defined logic

level. Leakage currents up to 10 μA from the high-impedance output could cause DE to drift to an incorrect logic state. Additionally, parasitic circuit board capacitance could cause coupling of VCC or GND to DE. These factors could improperly enable the driver.

When VCC rises, an internal pulldown circuit holds DE low for around 15 μs . After the initial power-up sequence, the pulldown circuit becomes transparent, resetting the hot-swap tolerable input.

Hot-Swap Input Circuitry

The MAX3460/MAX3463 enable inputs feature hot-swap capability. At the input there are two NMOS devices, M1 and M2 (Figure 4). When VCC ramps from 0, an internal 15 μs timer turns on M2 and sets the SR latch, which also turns on M1. Transistors M2, a 2mA current sink, and M1, a 100 μA current sink, pull DE to GND through a 5.6k Ω resistor. M2 is designed to pull DE to the disabled state against an external parasitic capacitance up to 100pF that can drive DE high. After 15 μs , the timer deactivates M2 while M1 remains on, holding DE low against three-state leakages that can drive DE high. M1 remains on until an external source overcomes the required input current. At this time, the SR latch resets and M1 turns off. When M1 turns off, DE reverts to a standard, high-impedance CMOS input. Whenever VCC drops below 1V, the hot-swap input is reset.

For RE there is a complimentary circuit employing two PMOS devices pulling RE to VCC.

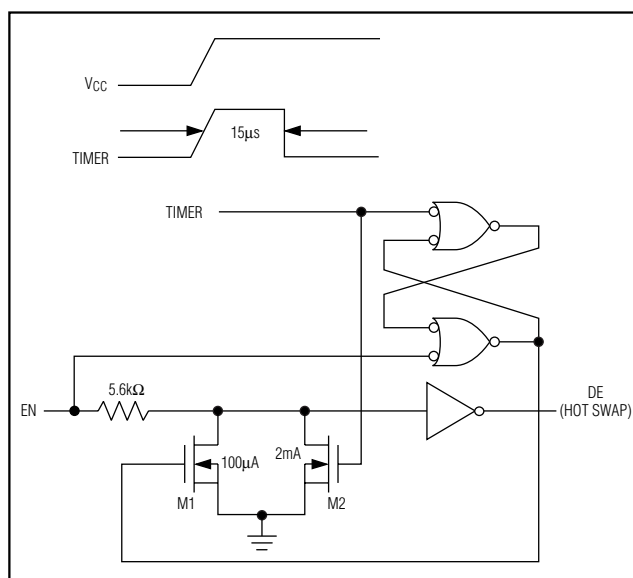

Figure 4. Simplified Structure of the Driver Enable Pin (DE)

+5V, Fail-Safe, 20Mbps, Profibus RS-485/

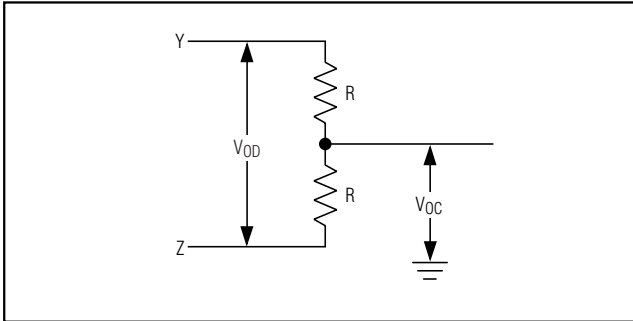

Figure 5. Driver DC Test Load

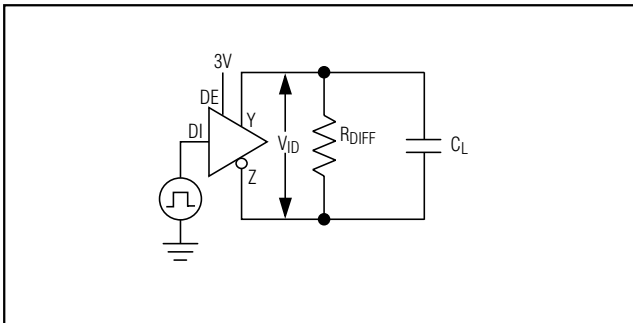

Figure 6. Driver Timing Test Circuit

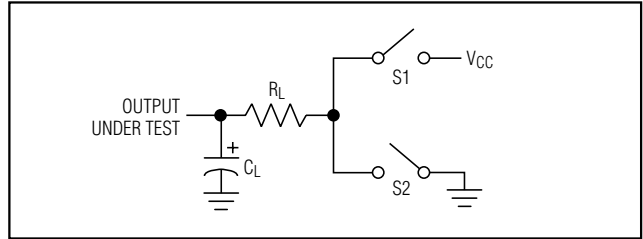

Figure 8. Enable/Disable Timing Test Load

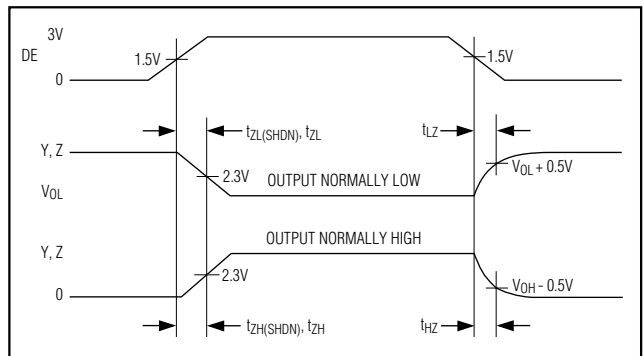

Figure 9. Driver Enable and Disable Times

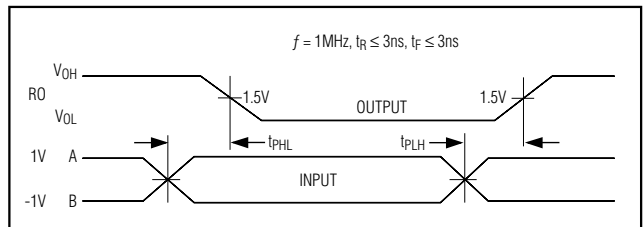

Figure 10. Receiver Propagation Delays

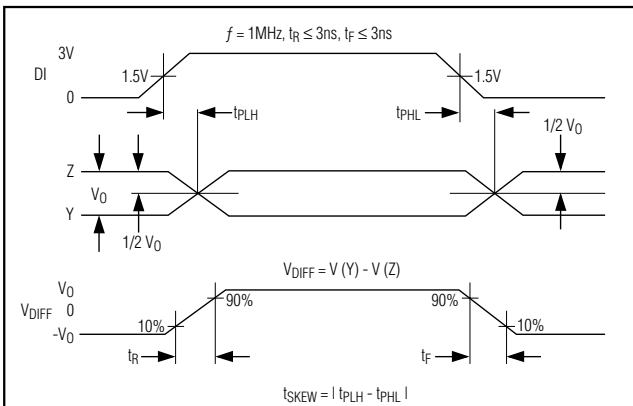

Figure 7. Driver Propagation Delays

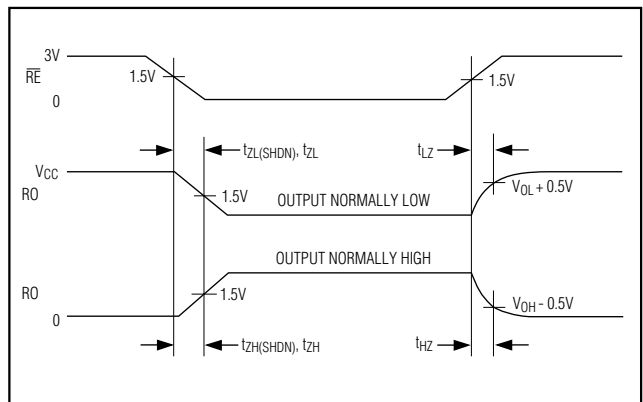

Figure 11. Receiver Enable and Disable Times

+5V, Fail-Safe, 20Mbps, Profibus RS-485/ RS-422 Transceivers

MAX3460-MAX3464

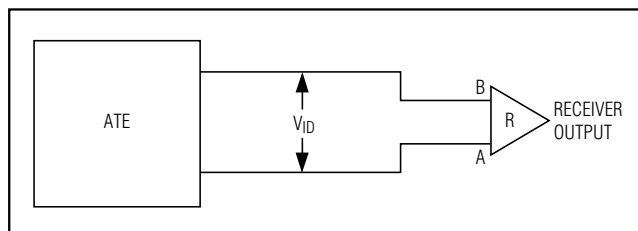

Figure 12. Receiver Propagation Delay Test Circuit

Applications Information

128 Transceivers on the Bus

The standard RS-485 receiver input impedance is $12k\Omega$ (one-unit load), and the standard driver can drive up to 32 unit loads. The MAX3460-MAX3464 family of transceivers has a 1/4-unit-load receiver input impedance ($48k\Omega$), allowing up to 128 transceivers to be connected in parallel on one communication line. Any combination of these devices and/or other RS-485 transceivers with a total of 32 unit loads or less can be connected to the line.

Low-Power Shutdown Mode (except MAX3462)

Low-power shutdown mode is initiated by bringing SHDN high (MAX3460/MAX3461), or both \overline{RE} high and DE low. In shutdown, the devices typically draw only $1\mu A$ of supply current. \overline{RE} and DE can be driven simultaneously; the parts are guaranteed not to enter shutdown if \overline{RE} is high and DE is low for less than 50ns. If the inputs are in this state for at least 800ns, the parts are guaranteed to enter shutdown.

Driver Output Protection

Two mechanisms prevent excessive output current and power dissipation caused by faults or by bus contention. The first, a foldback current limit on the output stage, provides immediate protection against short circuits over the whole common-mode voltage range (see *Typical Operating Characteristics*). The second, a thermal shutdown circuit, forces the driver outputs into a

high-impedance state if the die temperature exceeds $+140^\circ C$.

Propagation Delay

Many digital encoding schemes depend on the difference between the driver and receiver propagation delay times. Typical propagation delays are shown in the *Typical Operating Characteristics*. The difference in receiver delay times, $t_{PLH} - t_{PHL}$, is a maximum of 2ns. The driver skew time $t_{PLH} - t_{PHL}$ is also a maximum of 2ns.

Typical Applications

The MAX3460-MAX3464 transceivers are designed for bidirectional data communications on multipoint bus transmission lines. Figures 13 and 14 show typical network applications circuits. To minimize reflections, the line should be terminated at both ends in its characteristic impedance, and stub lengths off the main line should be kept as short as possible.

Profibus Termination

The MAX3460-MAX3464 are designed for driving Profibus termination networks. With a worst-case loading of two termination networks with 220Ω termination impedance and 390Ω pullups and pulldowns, the drivers can drive $V_{A-B} > 2.1V$ output.

Chip Information

TRANSISTOR COUNT: 610

PROCESS: BiCMOS

Ordering Information (continued)

PART	TEMP RANGE	PIN-PACKAGE
MAX3461CSD	$0^\circ C$ to $+70^\circ C$	14 SO
MAX3461CPD	$0^\circ C$ to $+70^\circ C$	14 Plastic DIP
MAX3461ESD	$-40^\circ C$ to $+85^\circ C$	14 SO
MAX3461EPD	$-40^\circ C$ to $+85^\circ C$	14 Plastic DIP
MAX3462CSA	$0^\circ C$ to $+70^\circ C$	8 SO
MAX3462CPA	$0^\circ C$ to $+70^\circ C$	8 Plastic DIP
MAX3462ESA	$-40^\circ C$ to $+85^\circ C$	8 SO
MAX3462EPA	$-40^\circ C$ to $+85^\circ C$	8 Plastic DIP
MAX3463CSA	$0^\circ C$ to $+70^\circ C$	8 SO
MAX3463CPA	$0^\circ C$ to $+70^\circ C$	8 Plastic DIP
MAX3463ESA	$-40^\circ C$ to $+85^\circ C$	8 SO
MAX3463EPA	$-40^\circ C$ to $+85^\circ C$	8 Plastic DIP
MAX3464CSA	$0^\circ C$ to $+70^\circ C$	8 SO
MAX3464CPA	$0^\circ C$ to $+70^\circ C$	8 Plastic DIP
MAX3464ESA	$-40^\circ C$ to $+85^\circ C$	8 SO
MAX3464EPA	$-40^\circ C$ to $+85^\circ C$	8 Plastic DIP

+5V, Fail-Safe, 20Mbps, Profibus RS-485/ RS-422 Transceivers

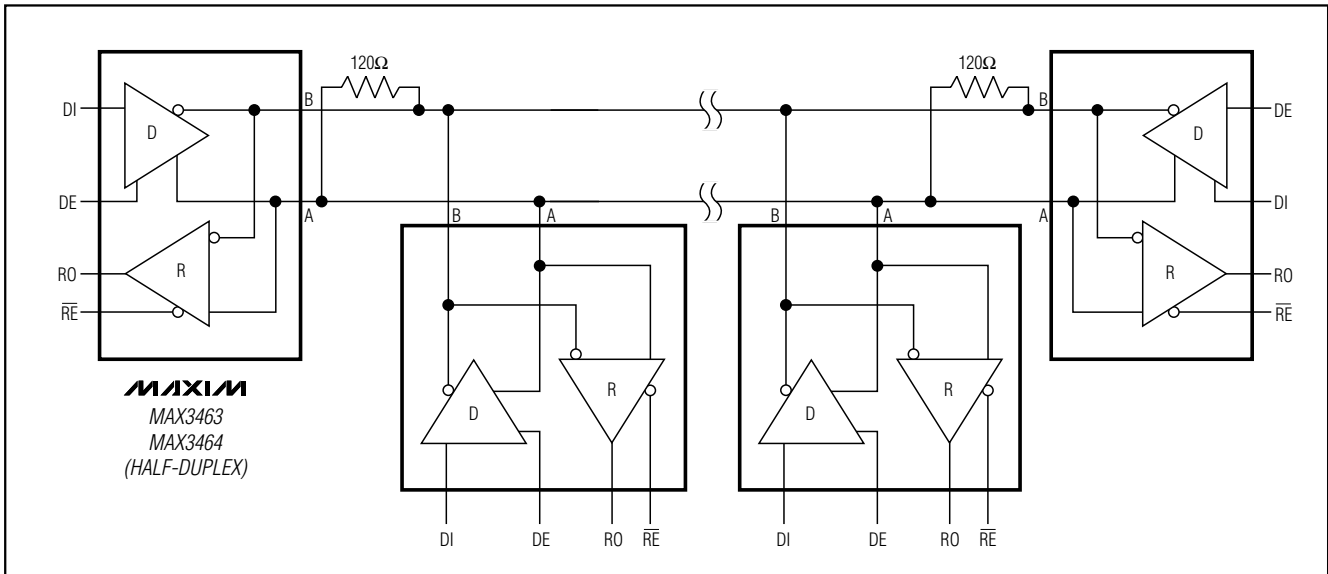

Figure 13. Typical Half-Duplex RS-485 Network

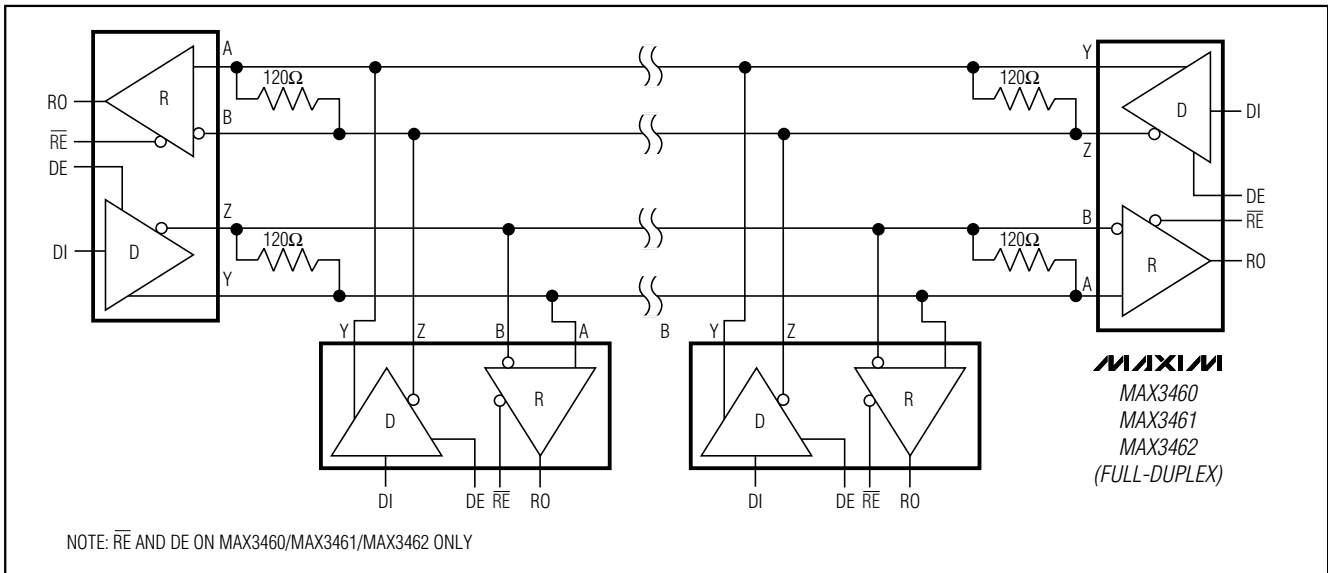

Figure 14. Typical Full-Duplex RS-485 Network

+5V, Fail-Safe, 20Mbps, Profibus RS-485/ RS-422 Transceivers

Package Information

(The package drawing(s) in this data sheet may not reflect the most current specifications. For the latest package outline information, go to www.maxim-ic.com/packages.)

MAX3460-MAX3464

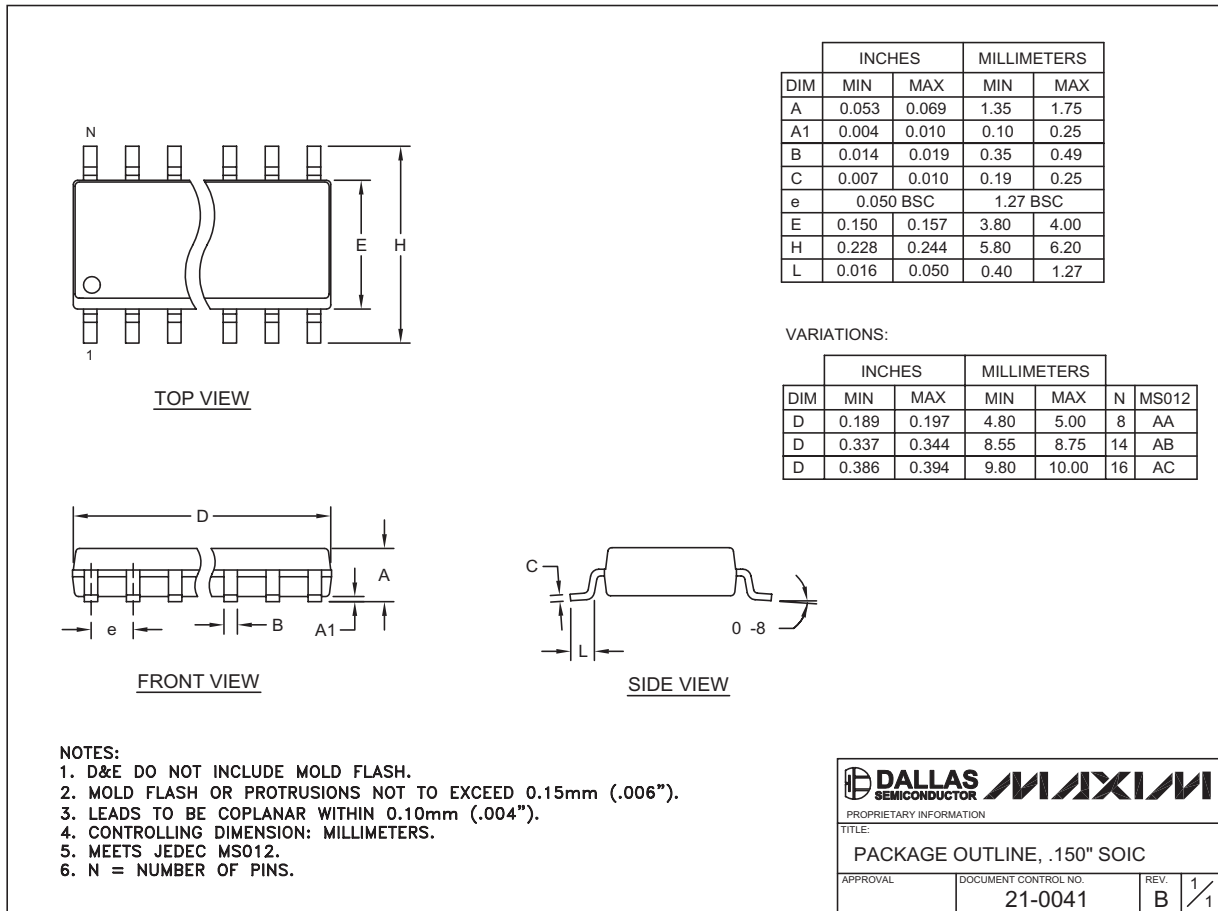

+5V, Fail-Safe, 20Mbps, Profibus RS-485/ RS-422 Transceivers

Package Information (continued)

(The package drawing(s) in this data sheet may not reflect the most current specifications. For the latest package outline information, go to www.maxim-ic.com/packages.)

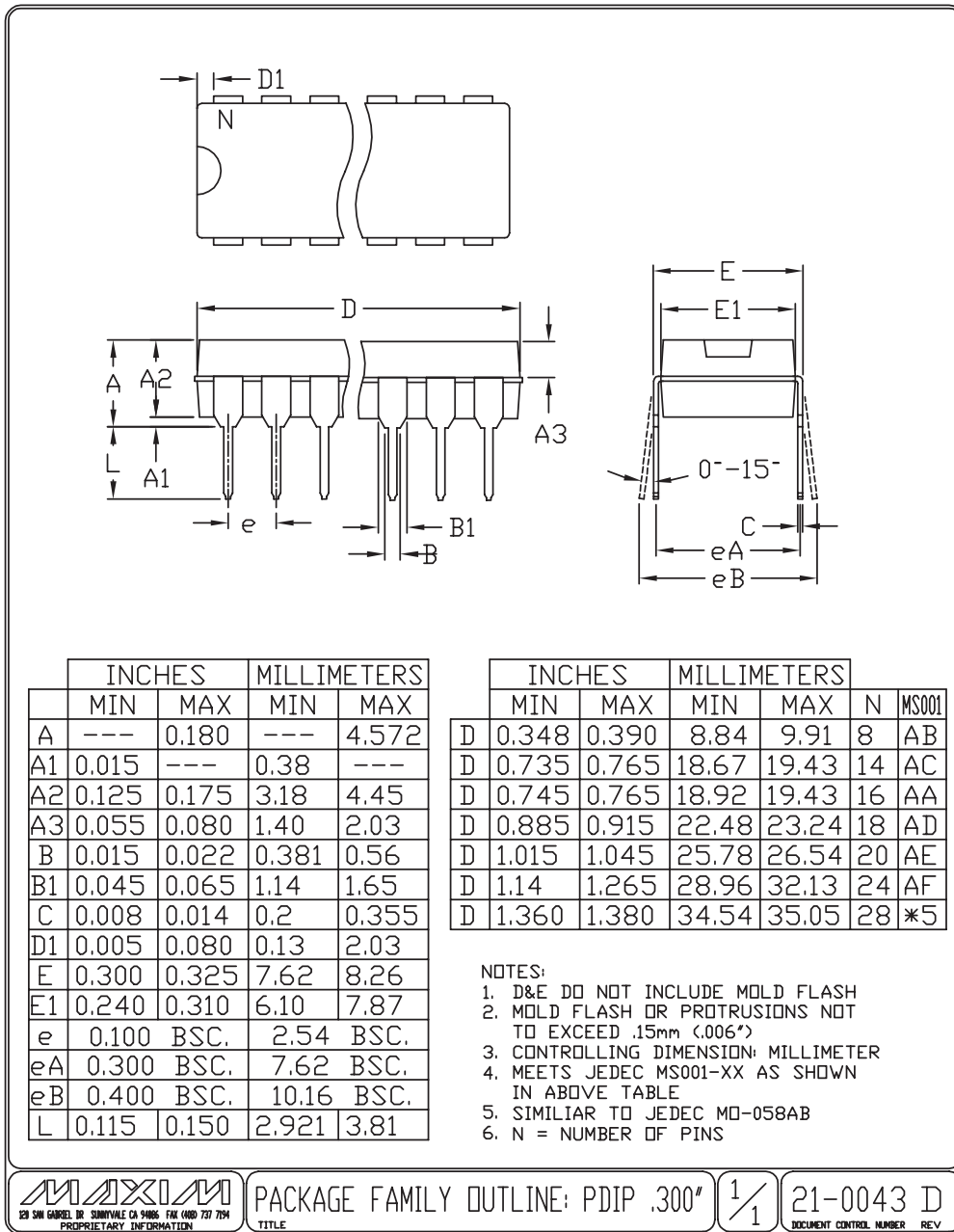

PDIP/LEPS



PACKAGE FAMILY OUTLINE: PDIP .300"

1/1

21-0043 D
DOCUMENT CONTROL NUMBER REV

Maxim cannot assume responsibility for use of any circuitry other than circuitry entirely embodied in a Maxim product. No circuit patent licenses are implied. Maxim reserves the right to change the circuitry and specifications without notice at any time.

14 Maxim Integrated Products, 120 San Gabriel Drive, Sunnyvale, CA 94086 408-737-7600