

Distributed by:

JAMECO[®]
ELECTRONICS

www.Jameco.com ♦ 1-800-831-4242

The content and copyrights of the attached
material are the property of its owner.

Jameco Part Number 2051274



3.5Ω, Single 8:1 and Dual 4:1, Low-Voltage Analog Multiplexers

MAX4638/MAX4639

General Description

The MAX4638/MAX4639 are single 8:1 and dual 4:1 CMOS analog multiplexers/demultiplexers (muxes/demuxes). Each mux operates from a single +1.8V to +5V supply or dual ±2.5V supplies. These devices feature 3.5Ω on-resistance (RON) when powered with a single +5V supply and have -75dB off-isolation and -85dB crosstalk from the output to each off channel. The switching times are 18ns tON and 7ns tOFF. They feature a -3dB 85MHz bandwidth and a guaranteed 0.25nA leakage current at +25°C.

A +1.8V to +5.5V operating range makes the MAX4638/MAX4639 ideal for battery-powered, portable instruments. All channels guarantee break-before-make switching. These parts feature bidirectional operation and can handle Rail-to-Rail® analog signals. All control inputs are TTL/CMOS-logic compatible. Decoding is in standard BCD format, and an enable input is provided to simplify cascading of devices. These devices are available in small 16-pin thin QFN, TSSOP, and SO packages, as well as a 20-pin thin QFN package.

Applications

- Automatic Test Equipment
- Low-Voltage Data-Acquisition Systems
- Audio and Video Signal Routing
- Medical Equipment
- Battery-Powered Equipment
- Relay Replacement

Features

- ◆ **Guaranteed RON**
3.5Ω (+5V or ±2.5V Supplies)
6Ω (+3V Supply)
- ◆ **Guaranteed 0.4Ω RON Match Between Channels**
- ◆ **Guaranteed 1Ω RON Flatness Over Signal Range**
- ◆ **Guaranteed Low Leakage Currents**
0.25nA at +25°C
- ◆ **Switching Times: tON = 18ns, tOFF = 7ns**
- ◆ **+1.8V to +5.5V Single-Supply Operation**
±2.5V Dual-Supply Operation
- ◆ **Rail-to-Rail Signal Handling**
- ◆ **TTL/CMOS-Logic Compatible**
- ◆ **Crosstalk: -80dB (1MHz)**
- ◆ **Off-Isolation: -60dB (10MHz)**

Ordering Information

PART	TEMP RANGE	PIN-PACKAGE
MAX4638ETE	-40°C to +85°C	16 Thin QFN (4 x 4)
MAX4638EUE	-40°C to +85°C	16 TSSOP
MAX4638ESE	-40°C to +85°C	16 SO
MAX4638ETP	-40°C to +85°C	20 Thin QFN (4 x 4)

Ordering Information continued at end of data sheet.

Pin Configurations/Functional Diagrams

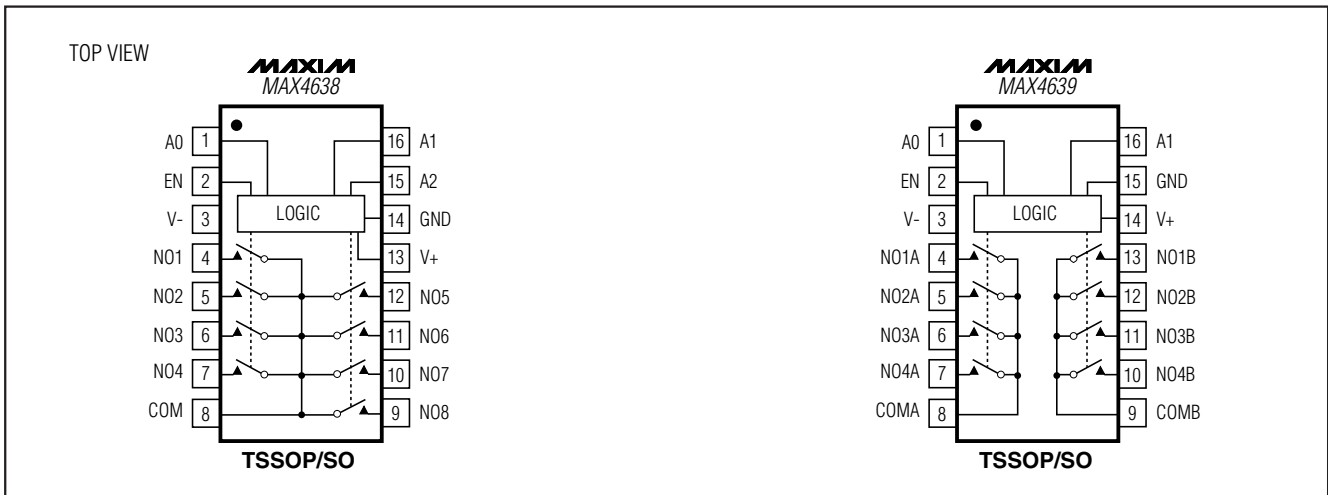

Rail-to-Rail is a registered trademark of Nippon Motorola, Ltd.



For pricing, delivery, and ordering information, please contact Maxim/Dallas Direct! at 1-888-629-4642, or visit Maxim's website at www.maxim-ic.com.

3.5Ω, Single 8:1 and Dual 4:1, Low-Voltage Analog Multiplexers

ABSOLUTE MAXIMUM RATINGS

(Voltages Referenced to GND)

V+ to V-+6V
V+, A ₋ , EN-0.3V to +6V
V-+0.3V to -6V
NO ₋ , COM ₋ (Note 1)-0.3V to (V+ + 0.3V)
Continuous Current A ₋ , EN±30mA
Continuous Current NO ₋ , COM ₋±100mA
Peak Current (NO ₋ , COM ₋) (pulsed at 1ms, 10% duty cycle)±200mA

Continuous Power Dissipation (T_A = +70°C)

16-Pin Thin QFN (derate 16.9mW/°C above +70°C)1349mW
16-Pin TSSOP (derate 5.7mW/°C above +70°C)457mW
16-Pin SO (derate 8.70mW/°C above +70°C)696mW
20-Pin Thin QFN (derate 16.9mW/°C above +70°C)1349mW
Operating Temperature Range	
MAX463_E_E-40°C to +85°C
Junction Temperature+150°C
Storage Temperature Range-65°C to +150°C
Lead Temperature (soldering, 10s)+300°C

Note 1: Signals on COM₋, NO₋ exceeding V+ or V- are clamped by internal diodes. A₋ and EN are clamped only to V- and can exceed V+ up to their maximum ratings. Limit forward-diode current to maximum current rating.

Stresses beyond those listed under "Absolute Maximum Ratings" may cause permanent damage to the device. These are stress ratings only, and functional operation of the device at these or any other conditions beyond those indicated in the operational sections of the specifications is not implied. Exposure to absolute maximum rating conditions for extended periods may affect device reliability.

ELECTRICAL CHARACTERISTICS—+5V Single Supply

(V+ = +5V ±10%, V- = 0, V_{IH} = +2.4V, V_{IL} = +0.8V, T_A = T_{MIN} to T_{MAX}, unless otherwise noted. Typical values are at T_A = +25°C.) (Note 9)

PARAMETER	SYMBOL	CONDITIONS	MIN	TYP (Note 2)	MAX	UNITS
ANALOG SWITCH						
Analog Signal Range	V _{COM-} , V _{NO-}		0		V+	V
On-Resistance	R _{ON}	V+ = +4.5V, I _{COM-} = 10mA, V _{NO-} = +3.5V		2.5	3.5	Ω
		T _A = T _{MIN} to T _{MAX}			4.5	
On-Resistance Match Between Channels (Notes 3, 8)	ΔR _{ON}	V+ = +4.5V, I _{COM-} = 10mA, V _{NO-} = +3.5V		0.1	0.4	Ω
		T _A = T _{MIN} to T _{MAX}			0.5	
On-Resistance Flatness (Note 4)	R _{FLAT(ON)}	V+ = +4.5V; I _{COM-} = 10mA; V _{NO-} = +1V, +2V, +3.5V		0.75	1	Ω
		T _A = T _{MIN} to T _{MAX}			1.2	
NO ₋ Off-Leakage Current (Note 5)	I _{NO-(OFF)}	V+ = +5.5V; V _{COM-} = +1V, +4.5V; V _{NO-} = +4.5V, +1V		±0.01	0.25	nA
		T _A = T _{MIN} to T _{MAX}	-0.25		0.35	
COM ₋ Off-Leakage Current (Note 5)	I _{COM-(OFF)}	V+ = +5.5V; V _{COM-} = +1V, +4.5V; V _{NO-} = +4.5V, +1V		±0.01	0.25	nA
		T _A = T _{MIN} to T _{MAX}	-0.25		0.75	
COM ₋ On-Leakage Current (Note 5)	I _{COM-(ON)}	V+ = +5.5V; V _{COM-} = +1V, +4.5V; V _{NO-} = +1V, +4.5V, or floating		±0.01	0.25	nA
		T _A = T _{MIN} to T _{MAX}	-0.75		0.75	
DIGITAL I/O						
Input Logic High	V _{IH}		2.4			V
Input Logic Low	V _{IL}				0.8	V
Input Leakage Current	I _{IH} , I _{IL}	V _{IN-} = 0 or V+	-0.1	0.005	0.1	μA
Digital Input Capacitance	C _{IN}			2		pF
DYNAMIC						
Transition Time (Note 5)	t _{TRANS}	R _L = 100Ω, C _L = 35pF, V _{NO1} = +3V or 0, V _{NO8} = 0 or +3V, Figure 2		14	18	ns
		T _A = T _{MIN} to T _{MAX}			20	

3.5Ω, Single 8:1 and Dual 4:1, Low-Voltage Analog Multiplexers

MAX4638/MAX4639

ELECTRICAL CHARACTERISTICS—+5V Single Supply (continued)

(V+ = +5V ±10%, V- = 0, V_{IH} = +2.4V, V_{IL} = +0.8V, T_A = T_{MIN} to T_{MAX}, unless otherwise noted. Typical values are at T_A = +25°C.) (Note 9)

PARAMETER	SYMBOL	CONDITIONS		MIN	TYP (Note 2)	MAX	UNITS
Break-Before-Make (Note 5)	t _{BBM}	R _L = 100Ω, C _L = 35pF, V _{NO-} = +3V, Figure 3	T _A = +25°C		8		ns
			T _A = T _{MIN} to T _{MAX}	1			
Enable Turn-On Time (Note 5)	t _{ON(EN)}	R _L = 100Ω, C _L = 35pF, V _{NO1} = +3V, V _{NO2} to V _{NO8} = 0, Figure 4	T _A = +25°C		14	18	ns
			T _A = T _{MIN} to T _{MAX}			20	
Enable Turn-Off Time (Note 5)	t _{OFF(EN)}	R _L = 100Ω, C _L = 35pF, V _{NO1} = +3V, V _{NO2} to V _{NO8} = 0, Figure 4	T _A = +25°C		5	7	ns
			T _A = T _{MIN} to T _{MAX}			8	
On-Channel -3dB Bandwidth	BW	Signal = 0dBm, C _L = 5pF, 50Ω in and out, Figure 6	MAX4638	T _A = +25°C		50	MHz
			MAX4639	T _A = +25°C		85	
Charge Injection	Q	V _{GEN} = +2.5V, R _{GEN} = 0, C _L = 1.0nF, Figure 5	T _A = +25°C		13		pC
NO_ Off-Capacitance	C _{NO_(OFF)}	V _{NO-} = 0V, f = 1MHz, Figure 8	T _A = +25°C		9		pF
COM_ Off-Capacitance	C _{COM_(OFF)}	V _{COM-} = 0V, f = 1MHz, Figure 8	MAX4638	T _A = +25°C		40	pF
			MAX4639	T _A = +25°C		20	
Switch On-Capacitance	C _(ON)	V _{COM-} = V _{NO-} = 0V, f = 1MHz, Figure 8	MAX4638	T _A = +25°C		54	pF
			MAX4639	T _A = +25°C		34	
Off-Isolation (Note 6)	V _{ISO}	C _L = 5pF, R _L = 50Ω, f = 1MHz, V _{NO-} = 1V _{RMS} , Figure 6	T _A = +25°C		-55		dB
		C _L = 5pF, R _L = 50Ω, f = 10MHz, V _{NO-} = 1V _{RMS} , Figure 6	T _A = +25°C		-75		
Crosstalk (Note 7)	V _{CT}	C _L = 5pF, R _L = 50Ω, f = 10MHz, V _{NO-} = 1V _{RMS} , Figure 7	T _A = +25°C		-65		dB
		C _L = 5pF, R _L = 50Ω, f = 1MHz, V _{NO-} = 1V _{RMS} , Figure 7	T _A = +25°C		-85		
Total Harmonic Distortion	THD	R _L = 600Ω, R _{FLAT(ON)/R_L}	T _A = +25°C		0.5		%
SUPPLY							
Positive Supply Current	I+	V+ = +5.5V, V _{IN} = 0 or V+			0.001	1.0	μA

3.5Ω, Single 8:1 and Dual 4:1, Low-Voltage Analog Multiplexers

ELECTRICAL CHARACTERISTICS—+3.0V Single Supply

(V+ = +2.7V to +3.3V, V- = 0, V_{IH} = +2.0V, V_{IL} = +0.4V, T_A = T_{MIN} to T_{MAX}, unless otherwise noted. Typical values are at V+ = +3V and T_A = +25°C.) (Note 9)

PARAMETER	SYMBOL	CONDITIONS		MIN	TYP (Note 2)	MAX	UNITS
ANALOG SWITCH							
Analog Signal Range	V _{COM_} , V _{NO_}			0		V+	V
On-Resistance	R _{ON}	I _{COM_} = 10mA, V _{NO_} = +1.7V	T _A = +25°C	4.5	6		Ω
			T _A = T _{MIN} to T _{MAX}			8	
On-Resistance Match Between Channels (Notes 3, 8)	ΔR _{ON}	I _{COM_} = 10mA, V _{NO_} = +1.7V	T _A = +25°C	0.25	0.6		Ω
			T _A = T _{MIN} to T _{MAX}			0.8	
On-Resistance Flatness (Note 4)	R _{FLAT(ON)}	I _{COM_} = 10mA; V _{NO_} = +1.5V, +1.7V, +1.9V	T _A = +25°C	1	2		Ω
			T _A = T _{MIN} to T _{MAX}			2.5	
NO_ Off-Leakage Current (Note 5)	I _{NO_(OFF)}	V+ = +3.3V; V _{COM_} = +1V, +3V; V _{NO_} = +3V, +1V	T _A = +25°C	-0.25	±0.01	0.25	nA
			T _A = T _{MIN} to T _{MAX}	-0.35		0.35	
COM_ Off-Leakage Current (Note 5)	I _{COM_(OFF)}	V+ = +3.3V; V _{COM_} = +1V, +3V; V _{NO_} = +3V, +1V	T _A = +25°C	-0.25	±0.01	0.25	nA
			T _A = T _{MIN} to T _{MAX}	-0.35		0.35	
COM_ On-Leakage Current (Note 5)	I _{COM_(ON)}	V+ = +3.3V; V _{COM_} = +1V, +3V; V _{NO_} = +1V, +3V, or floating	T _A = +25°C	-0.25	±0.01	0.25	nA
			T _A = T _{MIN} to T _{MAX}	-0.35		0.35	
DIGITAL I/O							
Input Logic High	V _{IH}			2.0			V
Input Logic Low	V _{IL}					0.4	V
Input Leakage Current	I _{IH} , I _{IL}	V _{IN_} = 0 or V+		-0.1	0.005	0.1	μA
Digital Input Capacitance	C _{IN}				2		pF
DYNAMIC							
Transition Time (Note 5)	t _{TRANS}	V _{NO_} = +2V, C _L = 35pF, R _L = 100Ω, Figure 2	T _A = +25°C	16	20		ns
			T _A = T _{MIN} to T _{MAX}			24	
Break-Before-Make (Note 5)	t _{BBM}	V _{NO_} = +2V, C _L = 35pF, R _L = 100Ω, Figure 3	T _A = +25°C	8			ns
			T _A = T _{MIN} to T _{MAX}	1			
Enable Turn-On Time (Note 5)	t _{ON(EN)}	V _{NO_} = +2V, C _L = 35pF, R _L = 100Ω, Figure 4	T _A = +25°C	15	20		ns
			T _A = T _{MIN} to T _{MAX}			24	
Enable Turn-Off Time (Note 5)	t _{OFF(EN)}	V _{NO_} = +2V, C _L = 35pF, R _L = 100Ω, Figure 4	T _A = +25°C	5	9		ns
			T _A = T _{MIN} to T _{MAX}			10	

3.5Ω, Single 8:1 and Dual 4:1, Low-Voltage Analog Multiplexers

MAX4638/MAX4639

ELECTRICAL CHARACTERISTICS—+3.0V Single Supply (continued)

(V+ = +2.7V to +3.3V, V- = 0, V_{IH} = +2.0V, V_{IL} = +0.4V, T_A = T_{MIN} to T_{MAX}, unless otherwise noted. Typical values are at V+ = +3V and T_A = +25°C.) (Note 9)

PARAMETER	SYMBOL	CONDITIONS		MIN	TYP (Note 2)	MAX	UNITS
Off-Isolation (Note 6)	V _{ISO}	C _L = 5pF, R _L = 50Ω, f = 10MHz, V _{NO-} = +1V _{RMS} , Figure 6	T _A = +25°C		55		dB
		C _L = 5pF, R _L = 50Ω, f = 1MHz, V _{NO-} = 1V _{RMS} , Figure 6	T _A = +25°C		-75		
Crosstalk (Note 7)	V _{CT}	C _L = 5pF, R _L = 50Ω, f = 10MHz, V _{NO-} = 1V _{RMS} , Figure 7	T _A = +25°C		-65		dB
		C _L = 5pF, R _L = 50Ω, f = 1MHz, V _{NO-} = 1V _{RMS} , Figure 7	T _A = +25°C		-85		
On-Channel -3dB Bandwidth	BW	Signal = 0dBm, 50Ω in and out, Figure 6	MAX4638	T _A = +25°C	50		MHz
			MAX4639	T _A = +25°C	85		
NO ₋ Off-Capacitance	C _{NO-(OFF)}	V _{NO-} = 0V, f = 1MHz, Figure 8	T _A = +25°C		9		pF
COM ₋ Off-Capacitance	C _{COM-(OFF)}	V _{COM-} = 0V, f = 1MHz, Figure 8	MAX4638	T _A = +25°C	40		pF
			MAX4639	T _A = +25°C	20		
Switch On-Capacitance	C _(ON)	V _{COM-} = V _{NO-} = 0V, f = 1MHz, Figure 8	MAX4638	T _A = +25°C	54		pF
			MAX4639	T _A = +25°C	34		
SUPPLY							
Positive Supply Current	I+	V+ = +3.3V, V _{IN-} = 0 or V+			0.001	1	μA

ELECTRICAL CHARACTERISTICS—±2.5V Dual Supplies

(V+ = +2.5 ±10%, V- = -2.5V ±10%, V_{IH} = +2.0V, V_{IL} = +0.4V, T_A = T_{MIN} to T_{MAX}, unless otherwise noted. Typical values are at V± = ±2.5V and T_A = +25°C.)

PARAMETER	SYMBOL	CONDITIONS		MIN	TYP (Note 2)	MAX	UNITS
ANALOG SWITCH							
Analog Signal Range	V _{COM-} , V _{NO-}			V-		V+	V
On-Resistance	R _{ON}	I _{COM-} = 10mA, V _{NO-} = ±1.5V, V+ = +2.25V, V- = -2.25V	T _A = +25°C		2.5	3.5	Ω
			T _A = T _{MIN} to T _{MAX}			4.5	
On-Resistance Match Between Channels (Notes 3, 8)	ΔR _{ON}	I _{COM-} = 10mA, V _{NO-} = ±1.5V, V+ = +2.25V, V- = -2.25V	T _A = +25°C		0.2	0.4	Ω
			T _A = T _{MIN} to T _{MAX}			0.5	

3.5Ω, Single 8:1 and Dual 4:1, Low-Voltage Analog Multiplexers

ELECTRICAL CHARACTERISTICS—±2.5V Dual Supplies (continued)

(V+ = +2.5 ±10%, V- = -2.5V ±10%, VIH = +2.0V, VIL = +0.4V, TA = TMIN to TMAX, unless otherwise noted. Typical values are at V± = ±2.5V and TA = +25°C.)

PARAMETER	SYMBOL	CONDITIONS	MIN	TYP (Note 2)	MAX	UNITS	
On-Resistance Flatness (Note 4)	RFLAT(ON)	ICOM_ = 10mA; VNO_ = ±1.5V, 0; V+ = +2.25V; V- = -2.25V	TA = +25°C	0.75	1	Ω	
			TA = TMIN to TMAX		1.2		
NO_ Off-Leakage Current (Note 5)	INO_ (OFF)	V+ = +2.75V; V- = -2.75V; VCOM_ = +1V, +2.5V; VNO_ = +2.5V, +1V	TA = +25°C	-0.25	±0.01	0.25	nA
			TA = TMIN to TMAX	-0.35		0.35	
COM_ Off-Leakage Current (Note 5)	ICOM_ (OFF)	V+ = +2.75V; V- = -2.75; VCOM_ = +1V, +2.5V; VNO_ = +2.5V, +1V	TA = +25°C	-0.25	±0.01	0.25	nA
			TA = TMIN to TMAX	-0.35		0.35	
COM_ On-Leakage Current (Note 5)	ICOM_ (ON)	V+ = +2.5V; V- = -2.5; VCOM_ = +1V, +2.5V; VNO_ = +1V, +2.5V, or floating	TA = +25°C	-0.25	±0.01	0.25	nA
			TA = TMIN to TMAX	-0.35		0.35	
DIGITAL I/O							
Input Logic High	VIH		2.0			V	
Input Logic Low	VIL				0.4	V	
Input Leakage Current	I _{IH} , I _{IL}	VIN_ = 0 or V+	-0.1	0.005	0.1	μA	
Digital Input Capacitance	CIN			2		pF	
DYNAMIC							
Transition Time (Note 5)	tTRANS	VNO_ = +1.2V, CL = 35pF, RL = 100Ω, Figure 2	TA = +25°C	16	20	ns	
			TA = TMIN to TMAX		24		
Enable Turn-On Time (Note 5)	tON(EN)	VNO_ = +1.2V, CL = 35pF, RL = 100Ω, Figure 4	TA = +25°C	14	18	ns	
			TA = TMIN to TMAX		20		
Enable Turn-Off Time (Note 5)	tOFF(EN)	VNO_ = +1.2V, CL = 35pF, RL = 100Ω, Figure 4	TA = +25°C	5	7	ns	
			TA = TMIN to TMAX		8		
Break-Before-Make (Note 5)	tBBM	VNO_ = +1.2V, CL = 35pF, RL = 100Ω, Figure 3	TA = +25°C	8		ns	
			TA = TMIN to TMAX	1			

Note 2: The algebraic convention, where the most negative value is a minimum and the most positive value a maximum, is used in this data sheet.

Note 3: $\Delta R_{ON} = R_{ON(MAX)} - R_{ON(MIN)}$.

Note 4: Flatness is defined as the difference between the maximum and minimum value of on-resistance as measured over the specified analog signal ranges.

Note 5: Guaranteed by design.

Note 6: Off-Isolation = $20 \log_{10} (V_{COM_} / V_{NO_})$. VCOM_ = output, VNO_ = input to off switch.

Note 7: Between any two switches.

Note 8: ΔR_{ON} matching specifications for thin QFN packaged parts are guaranteed by design.

Note 9: Parts are tested at +85°C and guaranteed by design over the entire temperature range.

3.5Ω, Single 8:1 and Dual 4:1, Low-Voltage Analog Multiplexers

Typical Operating Characteristics

($V_+ = +5V$, $V_- = 0$, $T_A = +25^\circ C$, unless otherwise noted.)

MAX4638/MAX4639

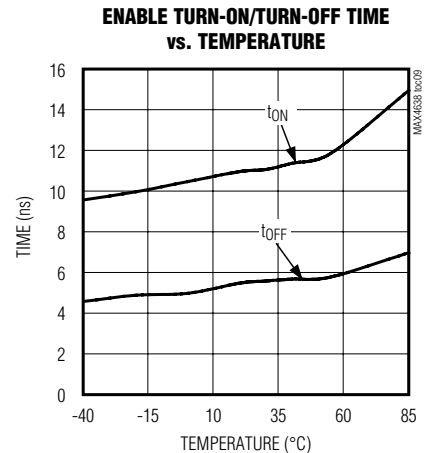
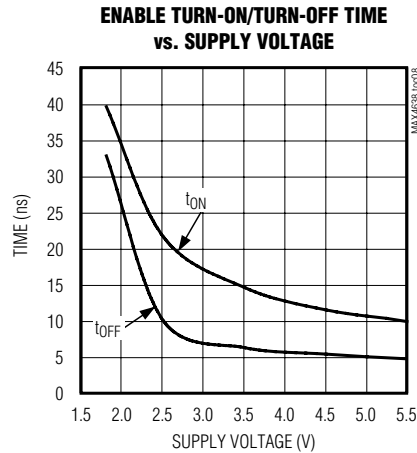
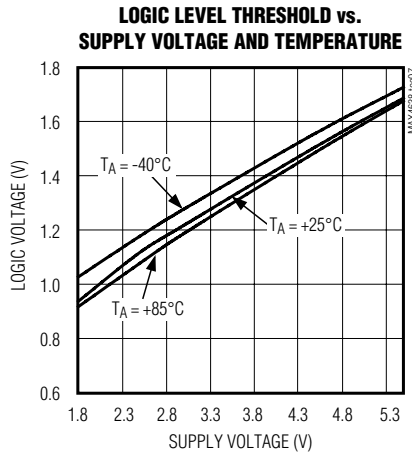
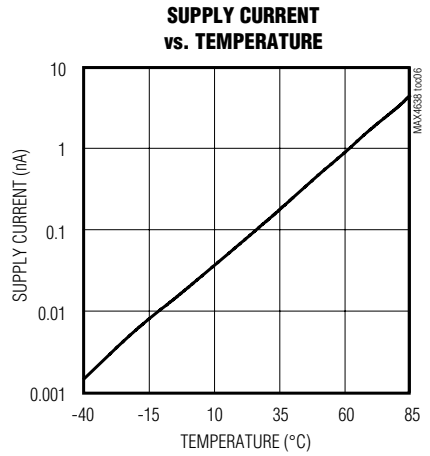
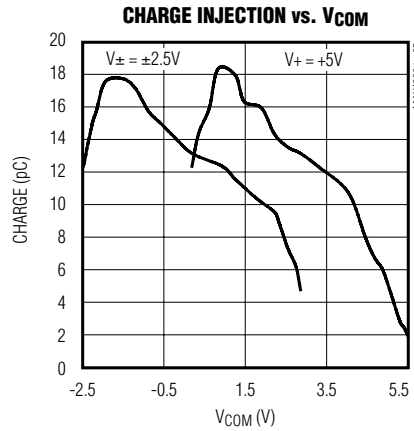
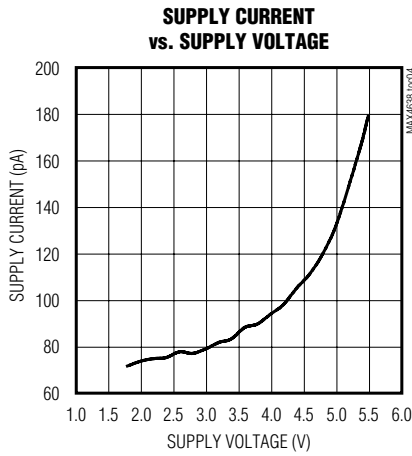
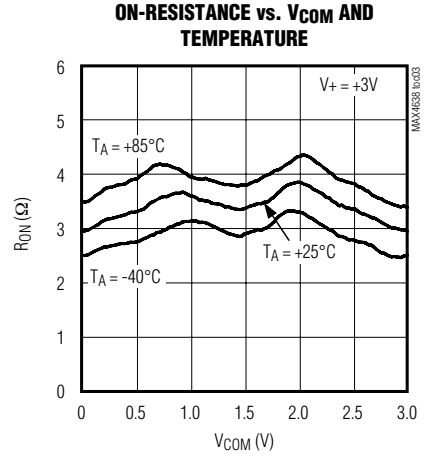
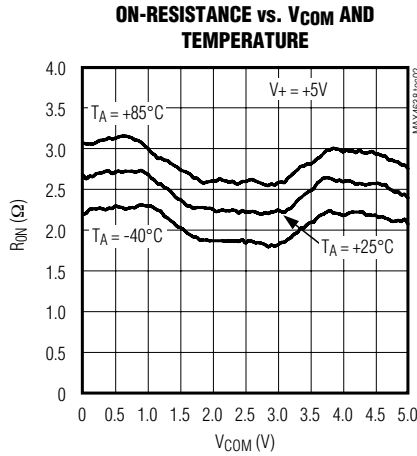
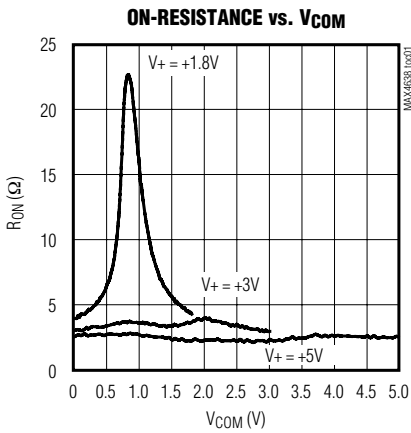

3.5Ω, Single 8:1 and Dual 4:1, Low-Voltage Analog Multiplexers

Typical Operating Characteristics (continued)

(V+ = +5V, V- = 0, T_A = +25°C, unless otherwise noted.)

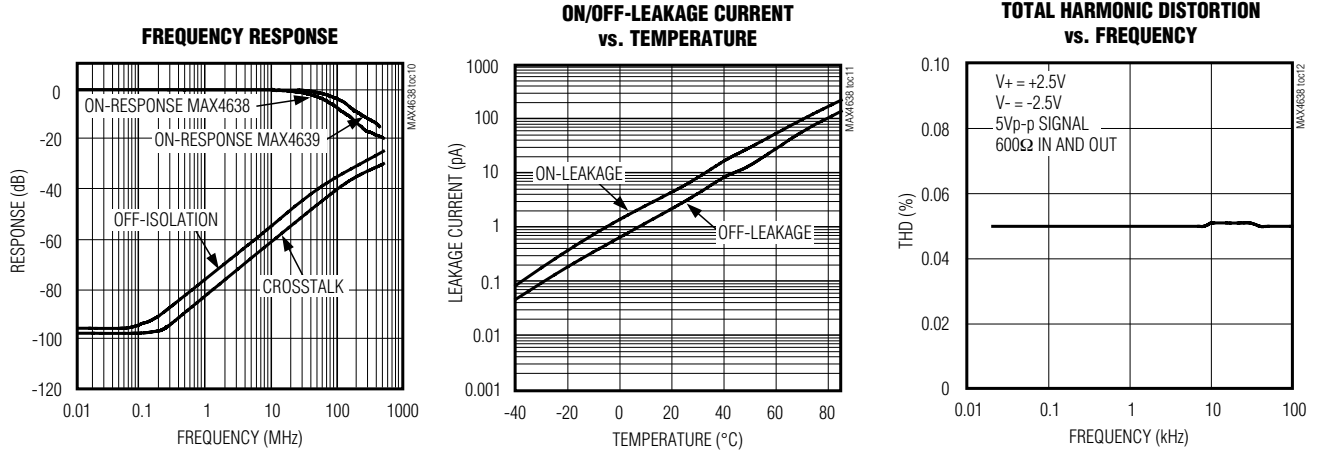

Pin Description

PIN						NAME	FUNCTION
MAX4638			MAX4639				
DIP/SO	THIN QFN		DIP/SO	THIN QFN			
	16-PIN	20-PIN		16-PIN	20-PIN		
1, 15, 16	15, 14, 13	19, 18, 17	—	—	—	A0, A2, A1	Address Inputs
—	—	—	1, 16	15, 14	19, 17	A0, A1	Address Inputs
2	16	1	2	16	1	EN	Enable
3	1	2	3	1	2	V-	Negative-Supply Voltage Input
4-7	2-5	3-6	—	—	—	NO1-NO4	Bidirectional Analog Inputs
—	—	—	4-7	2-5	3-6	NO1A-NO4A	Bidirectional Analog Inputs
8	6	7	—	—	—	COM	Bidirectional Analog outputs
—	—	—	8, 9	6, 7	7, 9	COMA, COMB	Bidirectional Analog outputs
9-12	7-10	10-13	—	—	—	NO8-NO5	Bidirectional Analog Inputs
—	—	—	10-13	8-11	10-13	NO4B-NO1B	Bidirectional Analog Inputs
13	11	14	14	12	14	V+	Positive-Supply Voltage Input
14	12	15	15	13	15	GND	Ground
—	—	8, 9, 16, 20	—	—	8, 16, 18, 20	N.C.	No Connection. Not internally connected.
—	EP	EP	—	EP	EP	PAD	Exposed Pad. Connect to V-.

3.5Ω, Single 8:1 and Dual 4:1, Low-Voltage Analog Multiplexers

MAX4638/MAX4639

Detailed Description

The MAX4638/MAX4639 are low-voltage, CMOS analog muxes. The MAX4638 is an 8:1 mux that switches one of eight inputs (NO1–NO8) to a common output (COM) as determined by the 3-bit binary inputs A0, A1, and A2. The MAX4639 is a 4:1 dual mux that switches one of four differential inputs to a common differential output as determined by the 2-bit binary inputs A0 and A1. Both the MAX4638/MAX4639 have an EN input that can be used to enable or disable the device. When disabled, all channels are switched off. See Truth Tables.

Applications Information

Overvoltage Protection

Proper power-supply sequencing is recommended for all CMOS devices. Do not exceed the absolute maximum ratings because stresses beyond the listed ratings can cause permanent damage to the devices. Always sequence V+ on first, then V-, followed by the logic inputs. If power-supply sequencing is not possible, add two small-signal diodes (D1, D2) in series with the supply pins for overvoltage protection (Figure 1). Adding diodes reduces the analog signal range to one diode drop below V+ and one diode drop above V-, but does not affect the devices' low switch resistance. Device operation is unchanged, and the difference between V+ and V- should not exceed 6V. These protection diodes are not recommended when using a single supply. For single-supply operation, V- should be connected to GND as close to the device as possible.

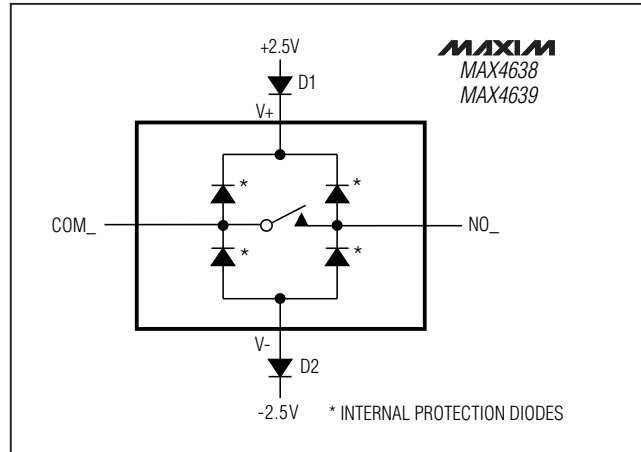

Figure 1. Overvoltage Protection Using External Blocking Diodes

Ordering Information (continued)

PART	TEMP RANGE	PIN-PACKAGE
MAX4639ETE	-40°C to +85°C	16 Thin QFN (4 × 4)
MAX4639EUE	-40°C to +85°C	16 TSSOP
MAX4639ESE	-40°C to +85°C	16 SO
MAX4639ETP	-40°C to +85°C	20 Thin QFN (4 × 4)

Truth Tables

MAX4638 (Single 8-to-1 Mux)

A2	A1	A0	EN	ON SWITCH
X	X	X	0	None
0	0	0	1	NO1
0	0	1	1	NO2
0	1	0	1	NO3
0	1	1	1	NO4
1	0	0	1	NO5
1	0	1	1	NO6
1	1	0	1	NO7
1	1	1	1	NO8

MAX4639 (Dual 4-to-1 Mux)

A1	A0	EN	COMA	COMB
X	X	0	None	None
0	0	1	NO1A	NO1B
0	1	1	NO2A	NO2B
1	0	1	NO3A	NO3B
1	1	1	NO4A	NO4B

3.5Ω, Single 8:1 and Dual 4:1, Low-Voltage Analog Multiplexers

Test Circuits/Timing Diagrams

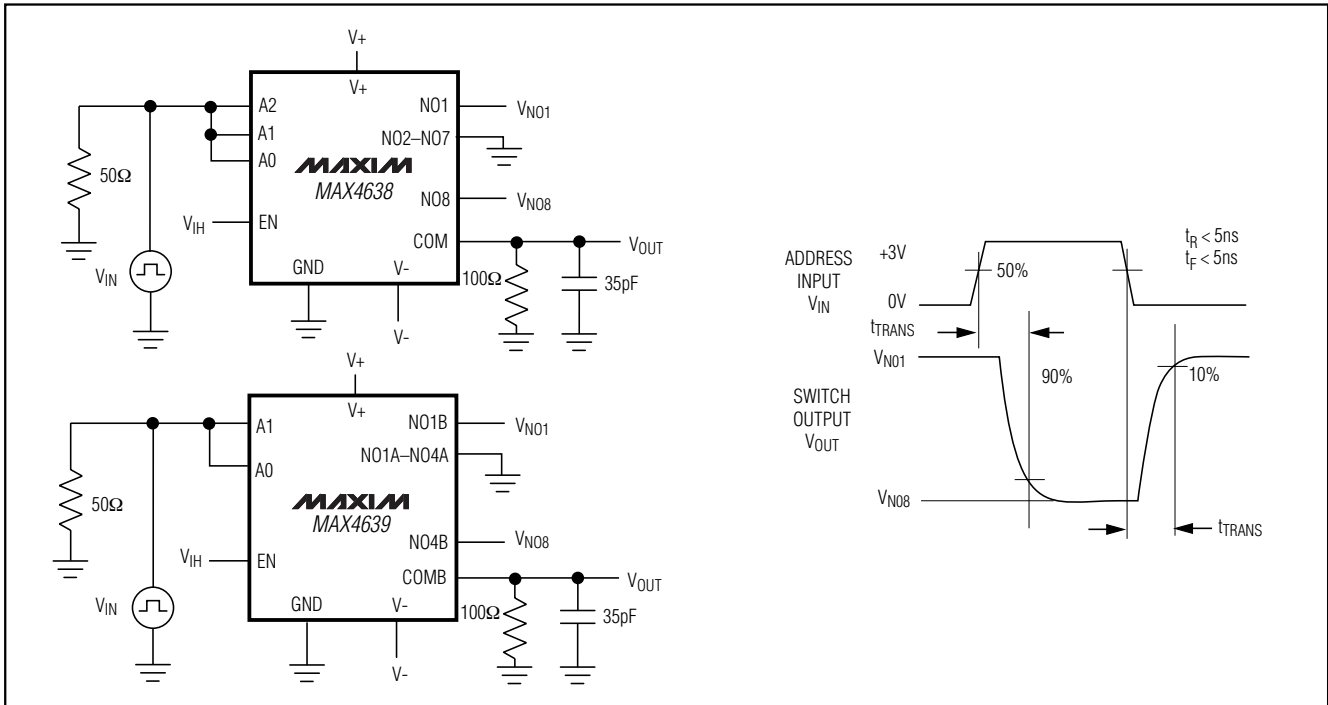

Figure 2. Transition Time

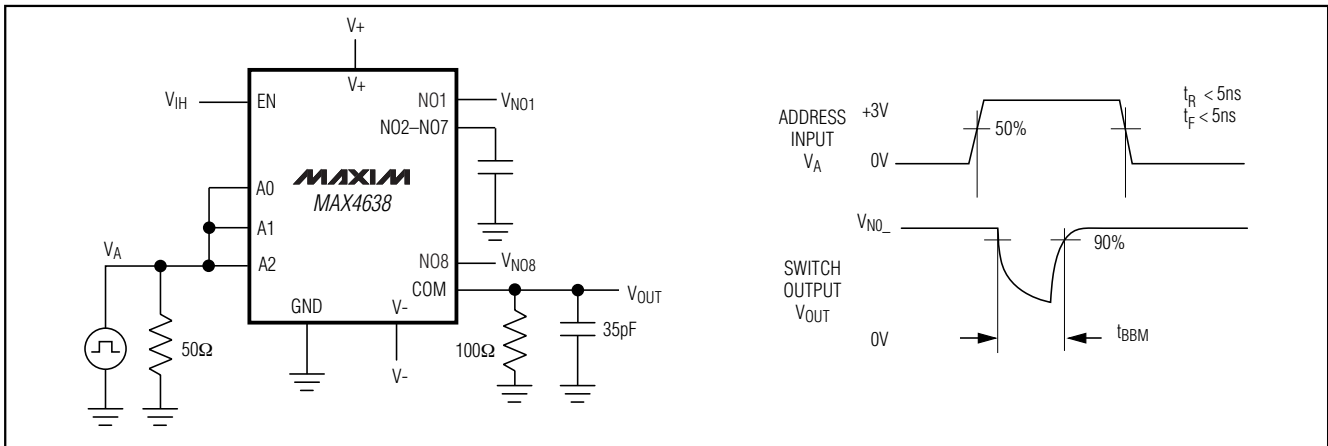

Figure 3. MAX4638 Break-Before-Make Interval

3.5Ω, Single 8:1 and Dual 4:1, Low-Voltage Analog Multiplexers

Test Circuits/Timing Diagrams (continued)

MAX4638/MAX4639

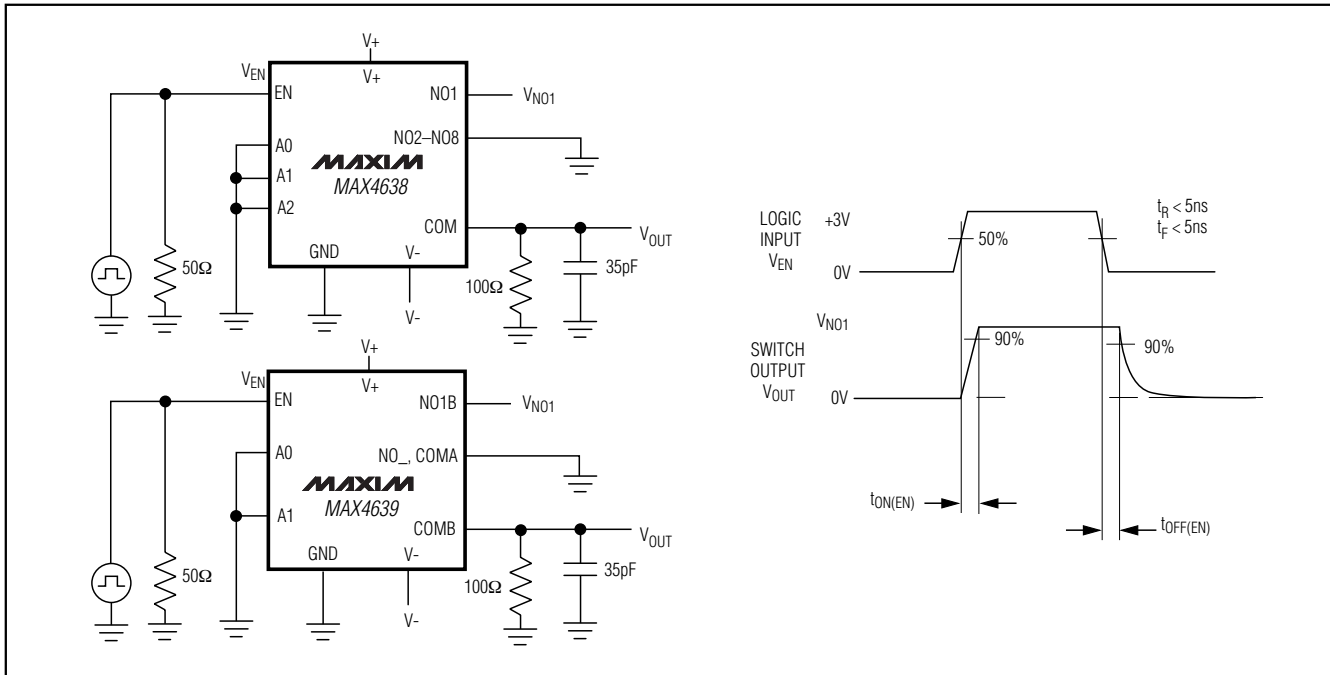

Figure 4. Enable Switching Time

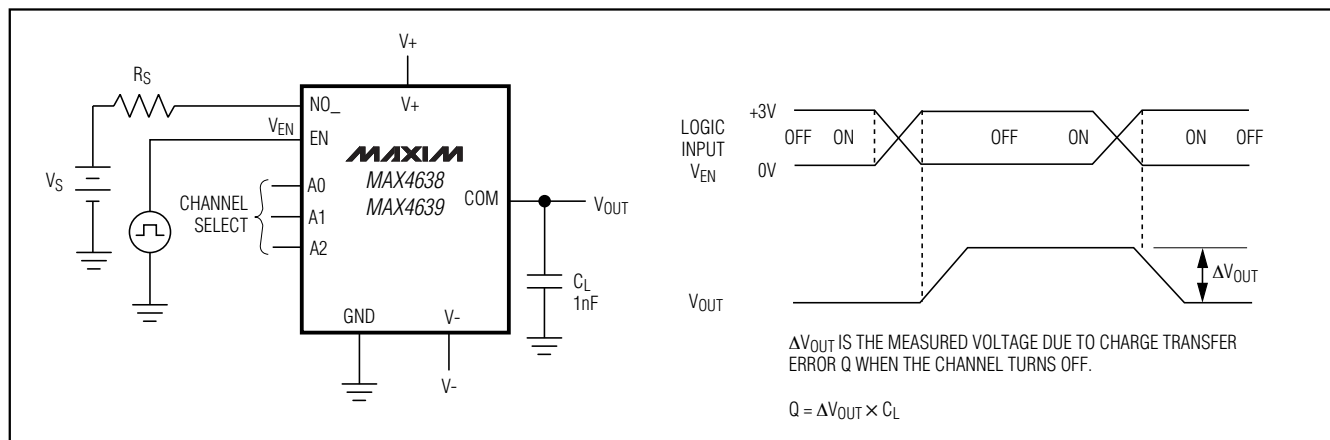

Figure 5. Charge Injection

3.5Ω, Single 8:1 and Dual 4:1, Low-Voltage Analog Multiplexers

Test Circuits/Timing Diagrams (continued)

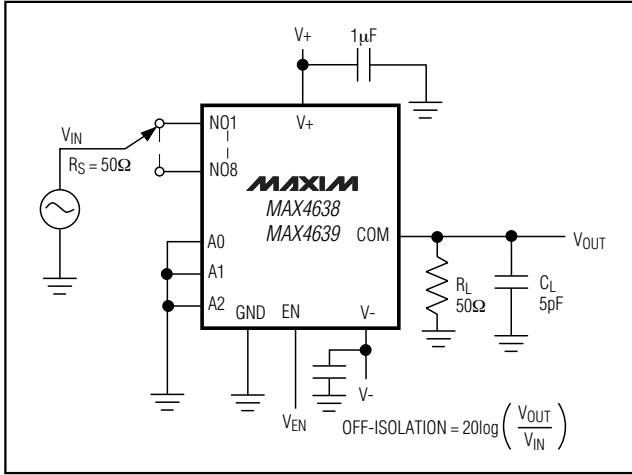

Figure 6. Off-Isolation/On-Channel Bandwidth

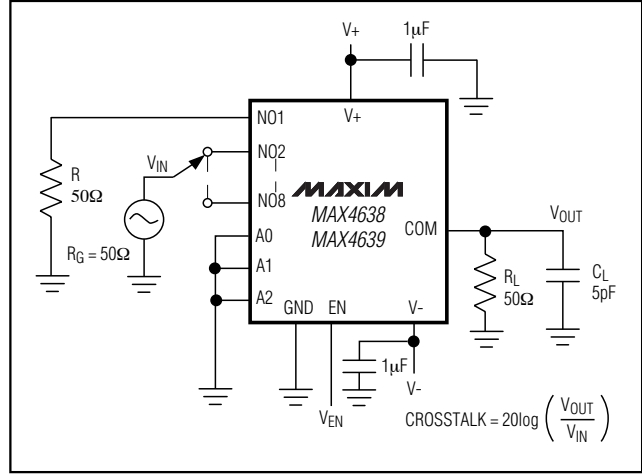

Figure 7. Crosstalk

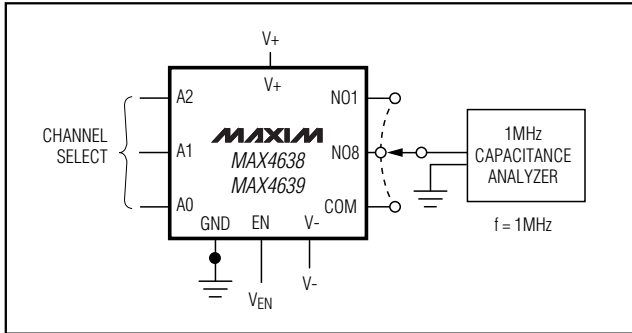

Figure 8. Channel Off/On-Capacitance

Chip Information

TRANSISTOR COUNT: 632

Note: Exposed pad on thin QFN packages is connected to V-.

3.5Ω, Single 8:1 and Dual 4:1, Low-Voltage Analog Multiplexers

Pin Configurations (continued)

MAX4638/MAX4639

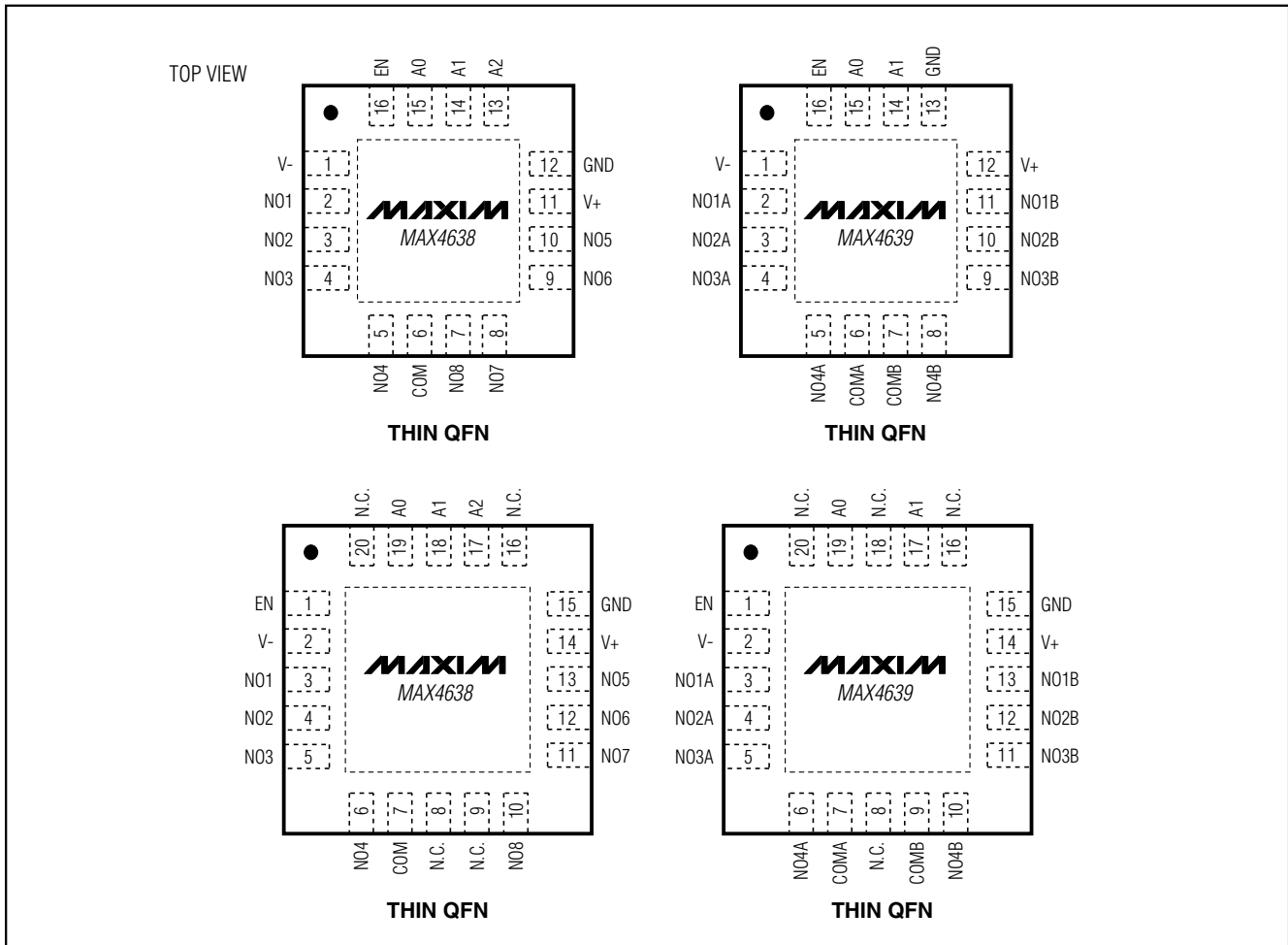

3.5Ω, Single 8:1 and Dual 4:1, Low-Voltage Analog Multiplexers

Package Information

(The package drawing(s) in this data sheet may not reflect the most current specifications. For the latest package outline information, go to www.maxim-ic.com/packages.)

TOP VIEW **BOTTOM VIEW**

SIDE VIEW **END VIEW**

DETAIL A

LEAD TIP DETAIL

SWD L	COMMON DIMENSIONS			
	MILLIMETERS		INCHES	
	MIN.	MAX.	MIN.	MAX.
A	—	1.10	.043	
A _i	0.05	0.15	.002	.006
A ₂	0.85	0.95	.033	.037
b	0.19	0.30	.007	.012
b _i	0.19	0.25	.007	.010
c	0.09	0.20	.004	.008
c _i	0.09	0.14	.004	.006
D	SEE VARIATIONS		SEE VARIATIONS	
E	4.30	4.50	.169	.177
e	.65 BSC		.026 BSC	
H	6.25	6.55	.246	.258
L	0.50	0.70	.020	.028
N	SEE VARIATIONS		SEE VARIATIONS	
α	0°	8°	0°	8°

JEDEC	MO-153	N	VARIATIONS			
			MILLIMETERS		INCHES	
			MIN.	MAX.	MIN.	MAX.
AB-1	14	D	4.90	5.10	.193	.201
AB	16	D	4.90	5.10	.193	.201
AC	20	D	6.40	6.60	.252	.260
AD	24	D	7.70	7.90	.303	.311
AE	28	D	9.60	9.80	.378	.386

NOTES:

- DIMENSIONS D AND E DO NOT INCLUDE FLASH
- MOLD FLASH OR PROTRUSIONS NOT TO EXCEED 0.15mm PER SIDE
- CONTROLLING DIMENSION: MILLIMETER
- MEETS JEDEC OUTLINE MO-153. SEE JEDEC VARIATIONS TABLE
- *N* REFERS TO NUMBER OF LEADS
- THE LEAD TIPS MUST LIE WITHIN A SPECIFIED ZONE. THIS TOLERANCE ZONE IS DEFINED BY TWO PARALLEL PLANES. ONE PLANE IS THE SEATING PLANE, DATUM [-C-]; THE OTHER PLANE IS AT THE SPECIFIED DISTANCE FROM [-C-] IN THE DIRECTION INDICATED

DALLAS SEMICONDUCTOR **MAXIM**

PROPRIETARY INFORMATION

TITLE:
PACKAGE OUTLINE, TSSOP 4.40mm BODY

APPROVAL	DOCUMENT CONTROL NO. 21-0066	REV. 1/1
----------	---------------------------------	----------

TSSOP4.40mm.EPS

3.5Ω, Single 8:1 and Dual 4:1, Low-Voltage Analog Multiplexers

Package Information (continued)

(The package drawing(s) in this data sheet may not reflect the most current specifications. For the latest package outline information, go to www.maxim-ic.com/packages.)

MAX4638/MAX4639

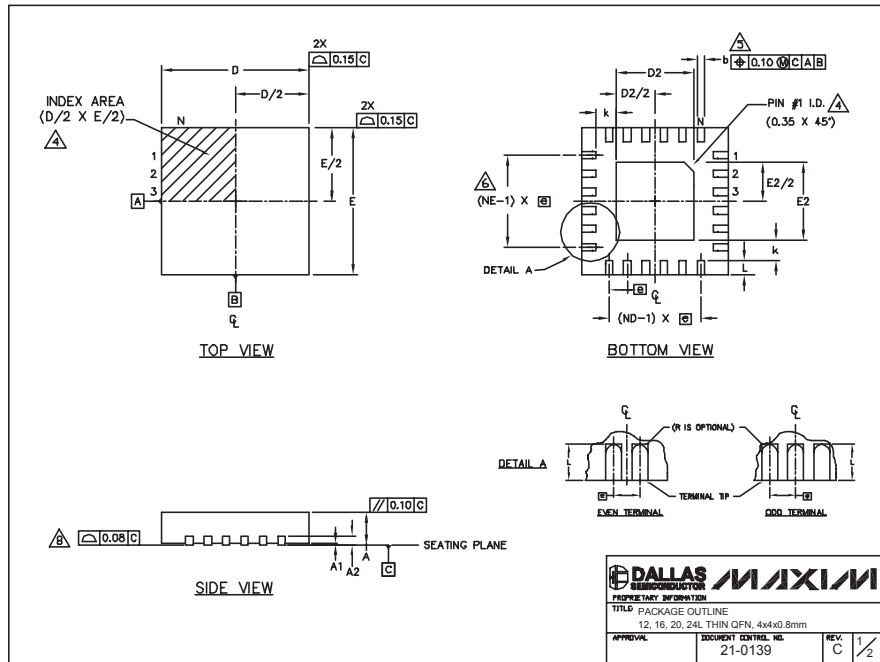

COMMON DIMENSIONS																
PKG	12L 4x4				16L 4x4				20L 4x4				24L 4x4			
REF.	MIN.	NOM.	MAX.	MIN.	NOM.	MAX.	MIN.	NOM.	MAX.	MIN.	NOM.	MAX.	MIN.	NOM.	MAX.	
A	0.70	0.75	0.80	0.70	0.75	0.80	0.70	0.75	0.80	0.70	0.75	0.80	0.70	0.75	0.80	
AL	0.0	0.02	0.05	0.0	0.02	0.05	0.0	0.02	0.05	0.0	0.02	0.05	0.0	0.02	0.05	
A2	0.20 REF.				0.20 REF.				0.20 REF.				0.20 REF.			
b	0.25	0.30	0.35	0.25	0.30	0.35	0.20	0.25	0.30	0.18	0.23	0.30				
D	3.90	4.00	4.10	3.90	4.00	4.10	3.90	4.00	4.10	3.90	4.00	4.10	3.90	4.00	4.10	
E	3.90	4.00	4.10	3.90	4.00	4.10	3.90	4.00	4.10	3.90	4.00	4.10	3.90	4.00	4.10	
e	0.80 BSC.				0.65 BSC.				0.50 BSC.				0.50 BSC.			
k	0.25	-	-	0.25	-	-	0.25	-	-	0.25	-	-				
L	0.43	0.53	0.65	0.45	0.55	0.65	0.43	0.53	0.65	0.30	0.40	0.50				
N	12				16				20				24			
ND	3				4				5				6			
NE	3				4				5				6			
Package Ver.	WGGB				WGGC				WGGD-1				WGGD-2			

EXPOSED PAD VARIATIONS								
PKG. CODES	D2			E2			DOWN BONDS ALLOWED	
	MIN.	NOM.	MAX.	MIN.	NOM.	MAX.		
T1244-2	1.95	2.30	2.25	1.95	2.10	2.25	NO	
T1244-3	1.95	2.30	2.25	1.95	2.10	2.25	YES	
T1244-4	1.95	2.30	2.25	1.95	2.10	2.25	NO	
T1644-2	1.95	2.30	2.25	1.95	2.10	2.25	NO	
T1644-3	1.95	2.30	2.25	1.95	2.10	2.25	YES	
T1644-4	1.95	2.30	2.25	1.95	2.10	2.25	NO	
T2044-1	1.95	2.30	2.25	1.95	2.10	2.25	NO	
T2044-2	1.95	2.30	2.25	1.95	2.10	2.25	YES	
T2044-3	1.95	2.30	2.25	1.95	2.10	2.25	NO	
T2444-1	2.45	2.60	2.63	2.45	2.60	2.63	NO	
T2444-2	1.95	2.30	2.25	1.95	2.10	2.25	YES	
T2444-3	2.45	2.60	2.63	2.45	2.60	2.63	YES	
T2444-4	2.45	2.60	2.63	2.45	2.60	2.63	NO	

NOTES:

- DIMENSIONING & TOLERANCING CONFORM TO ASME Y14.5M-1994.
- ALL DIMENSIONS ARE IN MILLIMETERS; ANGLES ARE IN DEGREES.
- N IS THE TOTAL NUMBER OF TERMINALS.
- THE TERMINAL #1 IDENTIFIER AND TERMINAL NUMBERING CONVENTION SHALL CONFORM TO JEDEC 95-1 SPP-012. DETAILS OF TERMINAL #1 IDENTIFIER ARE OPTIONAL, BUT MUST BE LOCATED WITHIN THE ZONE INDICATED. THE TERMINAL #1 IDENTIFIER MAY BE EITHER A MOLD OR MARKED FEATURE.
- DIMENSION b APPLIES TO METALLIZED TERMINAL AND IS MEASURED BETWEEN 0.25 mm AND 0.30 mm FROM TERMINAL TIP.
- ND AND NE REFER TO THE NUMBER OF TERMINALS ON EACH D AND E SIDE RESPECTIVELY.
- DEPOPULATION IS POSSIBLE IN A SYMMETRICAL FASHION.
- COPLANARITY APPLIES TO THE EXPOSED HEAT SINK SLUG AS WELL AS THE TERMINALS.
- DRAWING CONFORMS TO JEDEC MO220, EXCEPT FOR T2444-1, T2444-3 AND T2444-4.

DALLAS SEMICONDUCTOR **MAXIM**

PROPRIETARY INFORMATION

TITLE PACKAGE OUTLINE
12, 16, 20, 24L THIN QFN, 4x4x0.8mm

APPROVAL: _____ DOCUMENT CONTROL NO. 21-0139 REV. C 1/2

3.5Ω, Single 8:1 and Dual 4:1, Low-Voltage Analog Multiplexers

Package Information (continued)

(The package drawing(s) in this data sheet may not reflect the most current specifications. For the latest package outline information, go to www.maxim-ic.com/packages.)

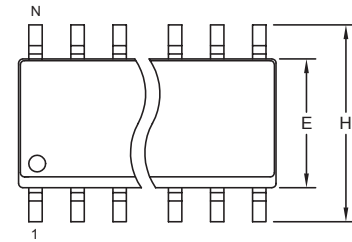

TOP VIEW

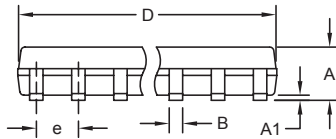

FRONT VIEW

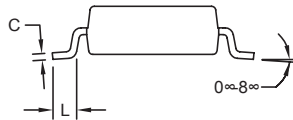

SIDE VIEW

DIM	INCHES		MILLIMETERS	
	MIN	MAX	MIN	MAX
A	0.053	0.069	1.35	1.75
A1	0.004	0.010	0.10	0.25
B	0.014	0.019	0.35	0.49
C	0.007	0.010	0.19	0.25
e	0.050 BSC		1.27 BSC	
E	0.150	0.157	3.80	4.00
H	0.228	0.244	5.80	6.20
L	0.016	0.050	0.40	1.27

VARIATIONS:

DIM	INCHES		MILLIMETERS		N	MS012
	MIN	MAX	MIN	MAX		
D	0.189	0.197	4.80	5.00	8	AA
D	0.337	0.344	8.55	8.75	14	AB
D	0.386	0.394	9.80	10.00	16	AC

NOTES:

1. D&E DO NOT INCLUDE MOLD FLASH.
2. MOLD FLASH OR PROTRUSIONS NOT TO EXCEED 0.15mm (.006").
3. LEADS TO BE COPLANAR WITHIN 0.10mm (.004").
4. CONTROLLING DIMENSION: MILLIMETERS.
5. MEETS JEDEC MS012.
6. N = NUMBER OF PINS.

<small>PROPRIETARY INFORMATION</small>	
<small>TITLE:</small> PACKAGE OUTLINE, .150" SOIC	
<small>APPROVAL</small>	<small>DOCUMENT CONTROL NO.</small> 21-0041
<small>REV.</small> B	<small>REV.</small> 1/1

SOICN EFS

Maxim cannot assume responsibility for use of any circuitry other than circuitry entirely embodied in a Maxim product. No circuit patent licenses are implied. Maxim reserves the right to change the circuitry and specifications without notice at any time.

Maxim Integrated Products, 120 San Gabriel Drive, Sunnyvale, CA 94086 408-737-7600 _____ 16

SITE
SEARCHPART NO.
SEARCH

WHAT'S NEW

PRODUCTS

SOLUTIONS

DESIGN

APPNOTES

SUPPORT

BUY

COMPANY

MEMBERS

MAX4638

Part Number Table

Notes:

1. See the [MAX4638 QuickView Data Sheet](#) for further information on this product family or download the [MAX4638 full data sheet](#) (PDF, 480KB).
2. Other options and links for purchasing parts are listed at: <http://www.maxim-ic.com/sales>.
3. [Didn't Find What You Need?](#) Ask our applications engineers. Expert assistance in finding parts, usually within one business day.
4. Part number suffixes: T or T&R = tape and reel; + = RoHS/lead-free; # = RoHS/lead-exempt. More: See [full data sheet](#) or [Part Naming Conventions](#).
5. * Some packages have variations, listed on the drawing. "PkgCode/Variation" tells which variation the product uses.

Part Number	Free Sample	Buy Direct	Package: TYPE PINS SIZE DRAWING CODE/VAR *	Temp	RoHS/Lead-Free? Materials Analysis
MAX4638ESE+	<input type="checkbox"/>	<input type="checkbox"/>	SOIC;16 pin;.150" Dwg: 21-0041B (PDF) Use pkgcode/variation: S16+2*	-40C to +85C	RoHS/Lead-Free: Yes Materials Analysis
MAX4638ESE+T	<input type="checkbox"/>	<input type="checkbox"/>	SOIC;16 pin;.150" Dwg: 21-0041B (PDF) Use pkgcode/variation: S16+2*	-40C to +85C	RoHS/Lead-Free: Yes Materials Analysis
MAX4638ESE	<input type="checkbox"/>	<input type="checkbox"/>	SOIC;16 pin;.150" Dwg: 21-0041B (PDF) Use pkgcode/variation: S16-2*	-40C to +85C	RoHS/Lead-Free: No Materials Analysis
MAX4638ESE-T	<input type="checkbox"/>	<input type="checkbox"/>	SOIC;16 pin;.150" Dwg: 21-0041B (PDF) Use pkgcode/variation: S16-2*	-40C to +85C	RoHS/Lead-Free: No Materials Analysis
MAX4638ETE	<input type="checkbox"/>	<input type="checkbox"/>	THIN QFN;16 pin;4X4X0.8mm Dwg: 21-0139E (PDF) Use pkgcode/variation: T1644-4*	-40C to +85C	RoHS/Lead-Free: No Materials Analysis
MAX4638ETE+	<input type="checkbox"/>	<input type="checkbox"/>	THIN QFN;16 pin;4X4X0.8mm Dwg: 21-0139E (PDF) Use pkgcode/variation: T1644+4*	-40C to +85C	RoHS/Lead-Free: Yes Materials Analysis
MAX4638ETE+T	<input type="checkbox"/>	<input type="checkbox"/>	THIN QFN;16 pin;4X4X0.8mm Dwg: 21-0139E (PDF) Use pkgcode/variation: T1644+4*	-40C to +85C	RoHS/Lead-Free: Yes Materials Analysis

MAX4638ETE-T			THIN QFN;16 pin;4X4X0.8mm Dwg: 21-0139E (PDF) Use pkgcode/variation: T1644-4*	-40C to +85C	RoHS/Lead-Free: No Materials Analysis
MAX4638EUE-T			TSSOP;16 pin;4.4mm Dwg: 21-0066I (PDF) Use pkgcode/variation: U16-2*	-40C to +85C	RoHS/Lead-Free: No Materials Analysis
MAX4638EUE+			TSSOP;16 pin;4.4mm Dwg: 21-0066I (PDF) Use pkgcode/variation: U16+2*	-40C to +85C	RoHS/Lead-Free: Yes Materials Analysis
MAX4638EUE+T			TSSOP;16 pin;4.4mm Dwg: 21-0066I (PDF) Use pkgcode/variation: U16+2*	-40C to +85C	RoHS/Lead-Free: Yes Materials Analysis
MAX4638EUE			TSSOP;16 pin;4.4mm Dwg: 21-0066I (PDF) Use pkgcode/variation: U16-2*	-40C to +85C	RoHS/Lead-Free: No Materials Analysis

[Didn't Find What You Need?](#)

[CONTACT US: SEND US AN EMAIL](#)