

Distributed by:

JAMECO[®]
ELECTRONICS

www.Jameco.com ♦ 1-800-831-4242

The content and copyrights of the attached
material are the property of its owner.

Jameco Part Number 2049609

MAXIM

High-Current, 25Ω, SPDT, CMOS Analog Switches

MAX4659/MAX4660

General Description

The MAX4659/MAX4660 are medium voltage CMOS analog switches with a low on-resistance of 25Ω max specifically designed to handle large switch currents. With a switch capability of up to 200mA peak current and 150mA continuous current (MAX4660), and up to 150mA peak current and 75mA continuous current (MAX4659), these parts can switch loads as low as 50Ω. They can replace reed relays with a million times the speed and a virtually unlimited number of lifetime cycles. Normal power consumption is only 3mW, whether the switch is on or off. These parts are TTL/CMOS compatible and will switch any voltage within their power-supply range.

The devices are single-pole/double-throw (SPDT) switches. The MAX4659/MAX4660 contain one normally closed (NC) switch and one normally open (NO) switch.

The MAX4659/MAX4660s' power-supply range is from ±4.5V to ±20V for dual-supply operation and +9V to +40V for single-supply operation. These switches can operate from any combination of supplies, within a 40V V+ to V- range. They conduct equally well in either direction and can handle Rail-to-Rail® analog signals. The off-leakage current is only 1nA max at T_A = +25°C. The MAX4659 is available in 8-pin μMAX and SO packages. The MAX4660 is available in thermally enhanced exposed paddle μMAX and SO packages.

Applications

Relay Replacement
 Test Equipment
 Communication Systems
 xDSL Modems
 PBX, PABX Systems
 Audio Signal Routing
 Audio Systems
 PC Multimedia Boards
 Redundant/Backup Systems

Rail-to-Rail is a registered trademark of Nippon Motorola, Ltd.

Features

- ◆ High Continuous Current Handling
 - 150mA Continuous Current (MAX4660)
 - 75mA Continuous Current (MAX4659)
- ◆ High Peak Current Handling
 - 200mA Peak Current (MAX4660)
 - 150mA Peak Current (MAX4659)
- ◆ 25Ω max On-Resistance (±15V Supplies)
- ◆ V_L Supply Not Required
- ◆ 1.5Ω max R_{ON} Flatness (±15V Supplies)
- ◆ Rail-to-Rail Signal Handling
- ◆ +12V Single Supply or ±15V Dual-Supply Operation
- ◆ Pin Compatible with DG419, MAX319

Ordering Information

PART	TEMP. RANGE	PIN-PACKAGE
MAX4659EUA	-40°C to +85°C	8 μMAX
MAX4659ESA	-40°C to +85°C	8 SO
MAX4660EUA	-40°C to +85°C	8 μMAX EP*
MAX4660ESA	-40°C to +85°C	8 SO EP*

* Exposed paddle

Pin Configuration

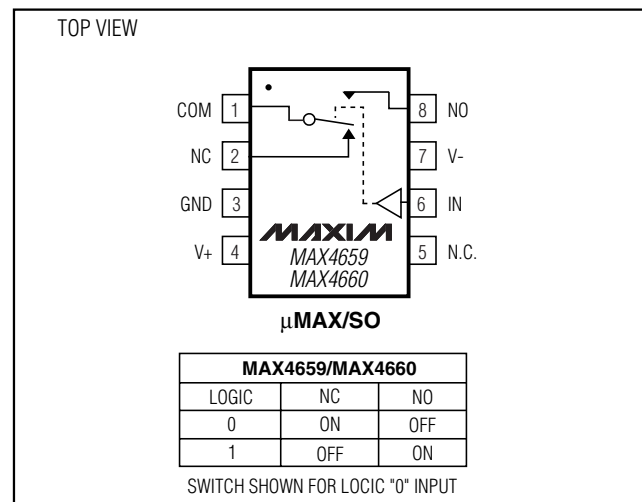
**MAXIM**

Maxim Integrated Products 1

For price, delivery, and to place orders, please contact Maxim Distribution at 1-888-629-4642, or visit Maxim's website at www.maxim-ic.com.

High-Current, 25Ω, SPDT, CMOS Analog Switches

ABSOLUTE MAXIMUM RATINGS

V+ to GND	-0.3V to +44V	8-Pin μMAX (derate 4.50mW/°C above +70°C)	
V- to GND	-44V to +0.3V	MAX4659	362mW
V+ to V-	-0.3V to +44V	8-Pin SO-EP (derate 18.9mW/°C above +70°C)	
All Other Pins to GND (Note 1)	(V- - 0.3V) to (V+ + 0.3V)	MAX4660	1509mW
Continuous Current COM, NO, NC (MAX4660)	±150mA	8-Pin SO (derate 5.88mW/°C above +70°C)	
Continuous Current COM, NO, NC (MAX4659)	±75mA	MAX4659	471mW
Continuous Current IN	±30mA	Operating Temperature Ranges	
Peak Current COM, NO, NC		MAX4659/MAX4660	-40°C to +85°C
MAX4660 (pulsed at 1ms, 10% duty cycle)	±200mA	Junction Temperature	+150°C
MAX4659 (pulsed at 1ms, 10% duty cycle)	±150mA	Storage Temperature Range	-65°C to +150°C
Continuous Power Dissipation (T _A = +70°C)		Lead Temperature (soldering, 10s)	+300°C
8-Pin μMAX-EP (derate 10.3mW/°C above +70°C)			
MAX4660	825mW		

Note 1: Signals on NO, NC, COM, or IN exceeding V+ or V- are clamped by internal diodes. Limit forward-diode current to maximum current rating.

Stresses beyond those listed under "Absolute Maximum Ratings" may cause permanent damage to the device. These are stress ratings only, and functional operation of the device at these or any other conditions beyond those indicated in the operational sections of the specifications is not implied. Exposure to absolute maximum rating conditions for extended periods may affect device reliability.

ELECTRICAL CHARACTERISTICS—Dual Supplies

(V+ = +15V, V- = -15V, V_{IH} = 2.4V, V_{IL} = 0.8V, T_A = T_{MIN} to T_{MAX}, unless otherwise noted. Typical values are at T_A = +25°C.) (Notes 2, 6)

PARAMETER	SYMBOL	CONDITIONS	T _A	MIN	TYP	MAX	UNITS
ANALOG SWITCH							
Analog Signal Range	V _{COM} , V _{NO} , V _{NC}			V-		V+	V
On-Resistance	R _{ON}	I _{COM} = 50mA; V _{NO} or V _{NC} = ±10V	+25°C		18	25	Ω
			T _{MIN} to T _{MAX}			30	
On-Resistance Matching Between Channels	ΔR _{ON}	I _{COM} = 50mA; V _{NO} or V _{NC} = ±10V	+25°C		0.4	1.2	Ω
			T _{MIN} to T _{MAX}			1.5	
On-Resistance Flatness (Note 3)	R _{FLAT} (ON)	I _{COM} = 50mA; V _{NO} or V _{NC} = -5V, 0, +5V	+25°C		0.5	1.5	Ω
			T _{MIN} to T _{MAX}			2	
NO or NC Off-Leakage Current (Note 4)	I _{NO} (OFF) or I _{NC} (OFF)	V _{COM} = -14.5V, +14.5V; V _{NO} or V _{NC} = +14.5V, -14.5V	+25°C	-1	0.01	1	nA
			T _{MIN} to T _{MAX}	-10		10	
COM On-Leakage Current (Note 4)	I _{COM} (ON)	V _{COM} = +14.5V, -14.5V; V _{NO} or V _{NC} = +14.5V, -14.5V, or floating	+25°C	-2	0.02	2	nA
			T _{MIN} to T _{MAX}	-20		20	
DYNAMIC CHARACTERISTICS							
Transition Time	t _{TRANS}	V _{NO} or V _{NC} = 10V; R _L = 300Ω, C _L = 35pF; Figure 3	+25°C		85	150	ns
			T _{MIN} to T _{MAX}			200	
Break-Before-Make Delay	t _{BBM}	V _{NO} or V _{NC} = 10V; R _L = 300Ω, C _L = 35pF; Figure 3	+25°C	10	20		ns
			T _{MIN} to T _{MAX}	5			

High-Current, 25Ω, SPDT, CMOS Analog Switches

MAX4659/MAX4660

ELECTRICAL CHARACTERISTICS—Dual Supplies (continued)

(V+ = +15V, V- = -15V, V_{IH} = 2.4V, V_{IL} = 0.8V, T_A = T_{MIN} to T_{MAX}, unless otherwise noted. Typical values are at T_A = +25°C.) (Notes 2, 6)

PARAMETER	SYMBOL	CONDITIONS	T _A	MIN	TYP	MAX	UNITS
Charge Injection	Q	V _{GEN} = 0, R _{GEN} = 0, C _L = 1nF, Figure 4	+25°C		1.5		pC
-3dB Bandwidth	BW		+25°C		225		MHz
Off-Isolation (Note 5)	V _{ISO}	f = 1MHz, R _L = 50Ω, Figure 5	+25°C		-70		dB
Total Harmonic Distortion	THD	f = 20Hz to 20kHz, V _{NL} = 5Vp-p, R _L = 600Ω	+25°C		0.005		%
Crosstalk	V _{CROSS}	R _L = 50Ω, C _L = 5pF, f = 1MHz, Figure 6	+25°C		-76		dB
NO or NC Off-Capacitance	C _{NO(OFF)} , C _{NC(OFF)}	f = 1MHz, Figure 7	+25°C		6		pF
COM On-Capacitance	C _{COM(ON)}	f = 1MHz, Figure 8	+25°C		25		pF
DIGITAL I/O							
Input Logic High	V _{IH}		T _{MIN} to T _{MAX}	2.4			V
Input Logic Low	V _{IL}		T _{MIN} to T _{MAX}			0.8	V
Input Leakage Current	I _{IN}	V _{IN} = 0.8V or 2.4V	T _{MIN} to T _{MAX}	-1		1	μA
POWER SUPPLY							
Power-Supply Range			T _{MIN} to T _{MAX}	±4.5		±20	V
Positive Supply Current	I+	V _{IN} = 0 or 5V, V _{NL} = 3V, I _{SWITCH} = 100mA, MAX4660; I _{SWITCH} = 50mA, MAX4659	+25°C	135	200		μA
			T _{MIN} to T _{MAX}			300	
Negative Supply Current	I-	V _{IN} = 0 or 5V, V _{NL} = 3V, I _{SWITCH} = 100mA, MAX4660; I _{SWITCH} = 50mA, MAX4659	+25°C	30	50		μA
			T _{MIN} to T _{MAX}			75	
Ground Current	I _{GND}	V _{IN} = 0 or 5V, V _{NL} = 3V, I _{SWITCH} = 100mA, MAX4660; I _{SWITCH} = 50mA, MAX4659	+25°C	100	175		μA
			T _{MIN} to T _{MAX}			225	

High-Current, 25Ω, SPDT, CMOS Analog Switches

ELECTRICAL CHARACTERISTICS—Single Supply

(V+ = +12V, V- = 0, VIH = 2.4V, VIL = 0.8V, TA = TMIN to TMAX, unless otherwise noted. Typical values are at TA = +25°C.) (Notes 2, 6)

PARAMETER	SYMBOL	CONDITIONS	TA	MIN	TYP	MAX	UNITS
ANALOG SWITCH							
Analog Signal Range	VIN		TMIN to TMAX	0		V+	V
On-Resistance	RON	ICOM = 25mA; VNO or VNC = +10V	+25°C	38	50		Ω
			TMIN to TMAX			60	
On-Resistance Matching Between Channels	ΔRON	ICOM = 25mA; VNO or VNC = ±10V	+25°C	0.4	2		Ω
			TMIN to TMAX			2.5	
On-Resistance Flatness (Note 3)	RFLAT (ON)	ICOM = 25mA; VNO or VNC = +2V, +6V, +10V	+25°C	4	7		Ω
			TMIN to TMAX			9	
DYNAMIC CHARACTERISTICS							
Transition Time	tTRANS	VNO or VNC = 10V; RL = 300Ω; CL = 35pF, Figure 2	+25°C	120	200		ns
			TMIN to TMAX			250	
Break-Before-Make Delay	tBBM	VNO or VNC = 10V; RL = 300 Ω; CL = 35pF, Figure 2	+25°C	20	50		ns
			TMIN to TMAX	10			
Charge Injection	Q	VGEN = 0, RGEN = 0, CL = 1nF, Figure 4	+25°C	1			pC
POWER SUPPLY							
Power-Supply Range	V+			+9		+40	V
Positive Supply Current	I+	VIN = 0 or 12V, VNL = 3V; ISWITCH = 50mA, MAX4660; ISWITCH = 25mA, MAX4659	+25°C	50	100		μA
			TMIN to TMAX			125	
		VIN = 5V, VNL = 3V; ISWITCH = 50mA, MAX4660; ISWITCH = 25mA, MAX4659	+25°C	70	125		
			TMIN to TMAX			150	

Note 2: The algebraic convention is used in this data sheet; the most negative value is shown in the minimum column.

Note 3: Flatness is defined as the difference between the maximum and minimum value of on-resistance as measured over the specified analog signal range.

Note 4: Leakage parameters are 100% tested at maximum-rated hot temperature and guaranteed by correlation at TA = +25°C.

Note 5: Off-isolation = 20log10 [VCOM / (VNC or VNO)], VCOM = output, VNC or VNO = input to off switch.

Note 6: -40°C specifications are guaranteed by design.

High-Current, 25Ω, SPDT, CMOS Analog Switches

Typical Operating Characteristics

($T_A = +25^\circ\text{C}$, unless otherwise noted.)

MAX4659/MAX4660

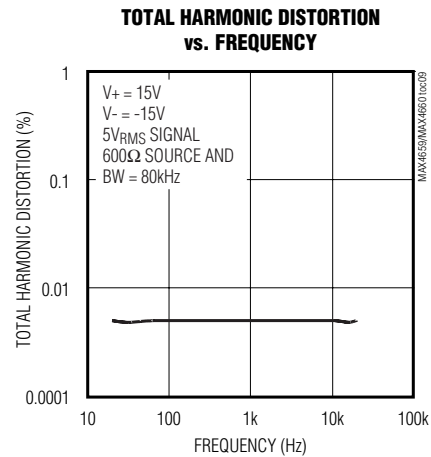
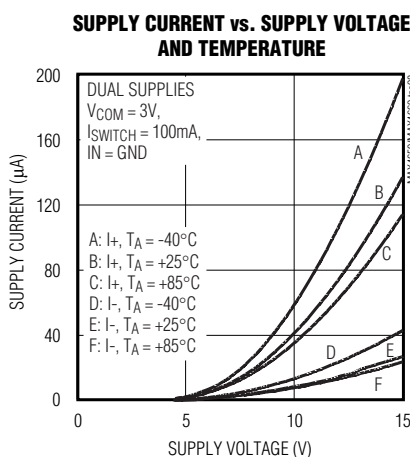
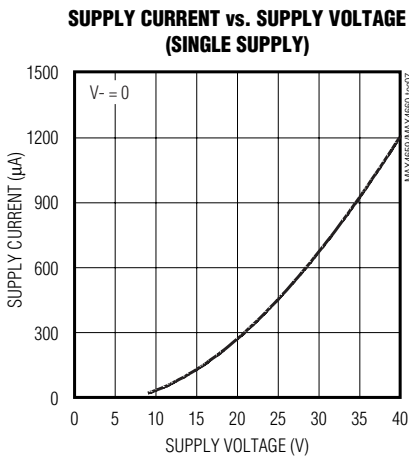
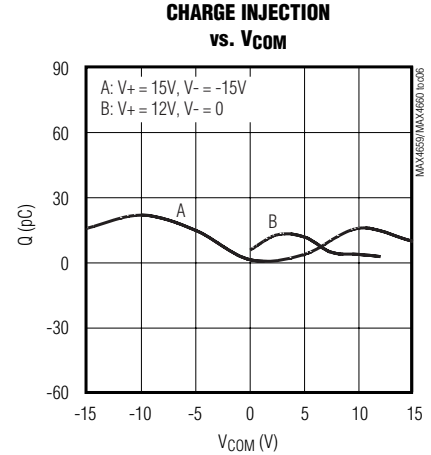
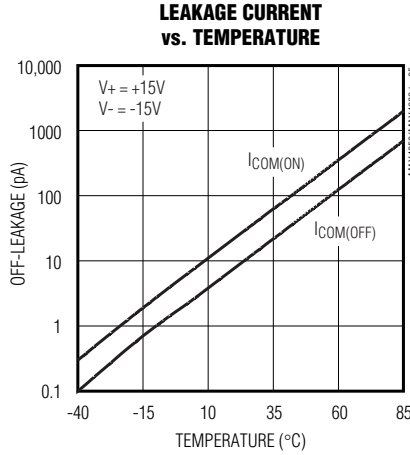
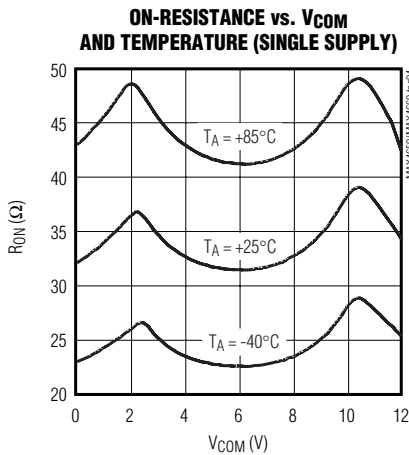
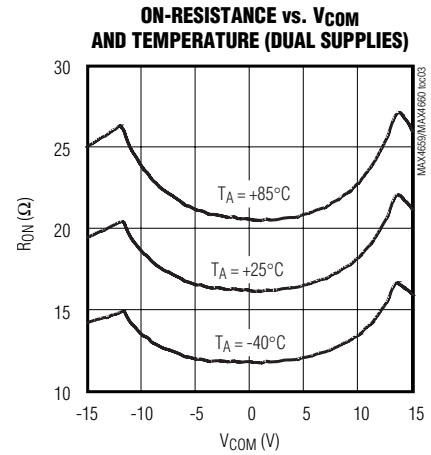
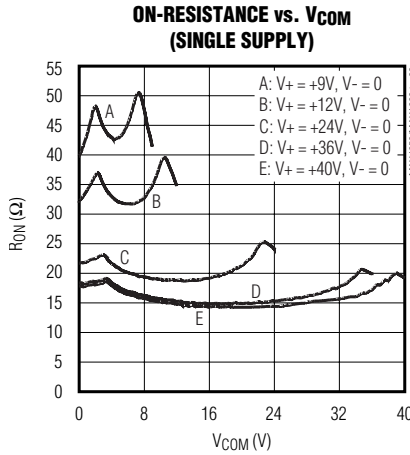
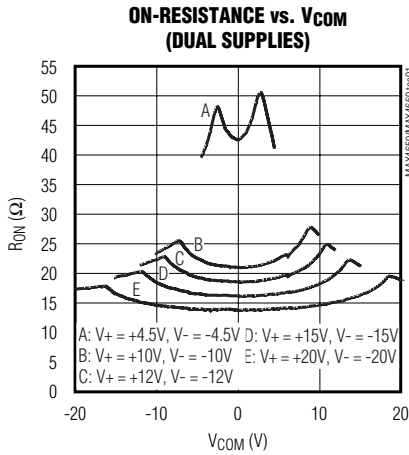

High-Current, 25Ω, SPDT, CMOS Analog Switches

Typical Operating Characteristics (continued)

(T_A = +25°C, unless otherwise noted.)

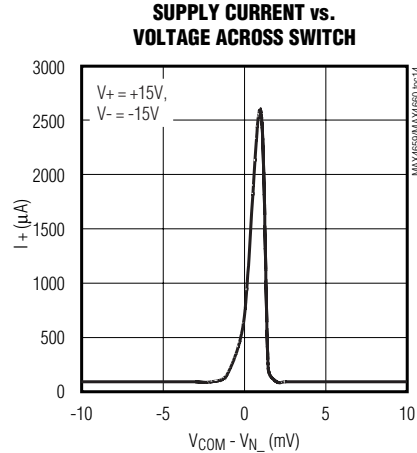
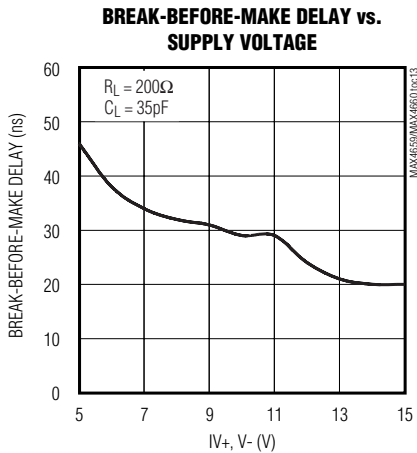
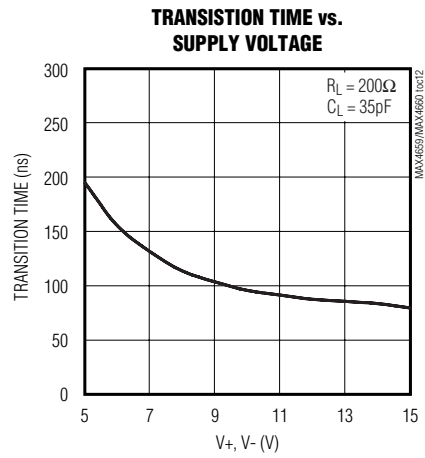
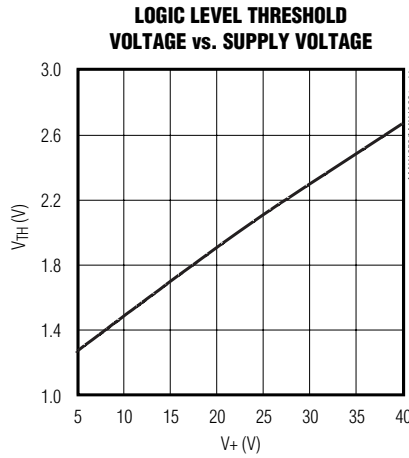
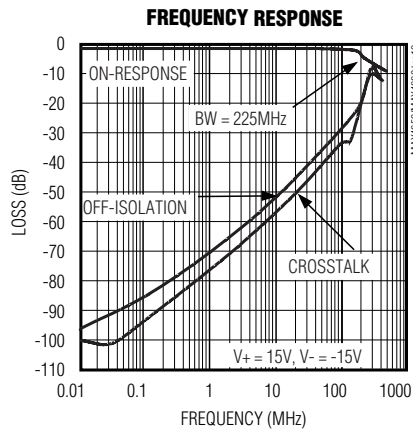

Pin Description

PIN	NAME	FUNCTION
1	COM	Analog Switch Common
2	NC	Normally Closed Switch Terminal. NC is connected to COM when IN is low.
3	GND	Ground
4	V+	Positive Supply Voltage Input
5	N.C.	No Connection
6	IN	Digital Control Input
7	V-	Negative Supply Voltage Input
8	NO	Normally Open Switch Terminal. NO is connected to COM when IN is high.

High-Current, 25Ω, SPDT, CMOS Analog Switches

Test Circuits/Timing Diagrams

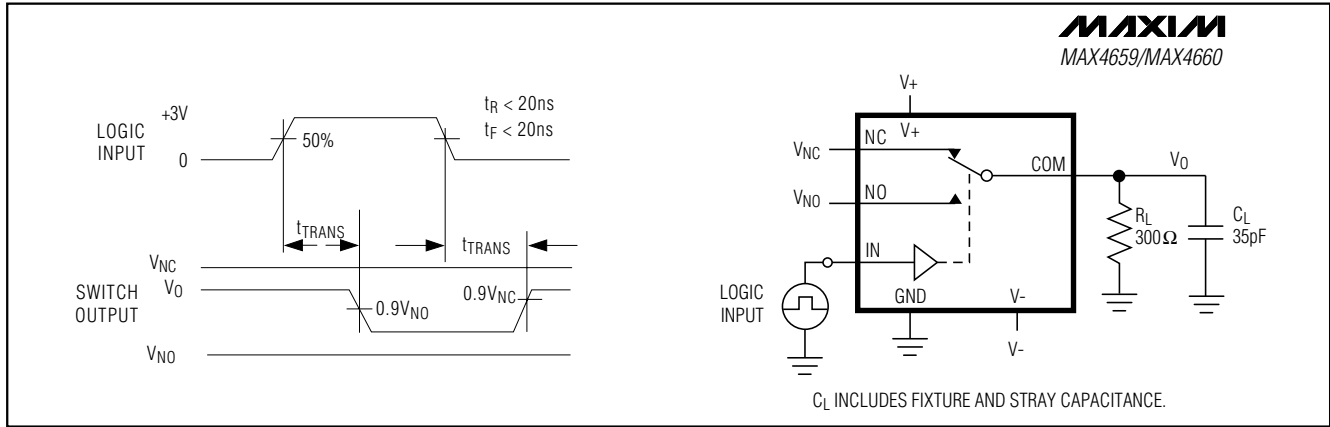

Figure 2. Functional Diagram

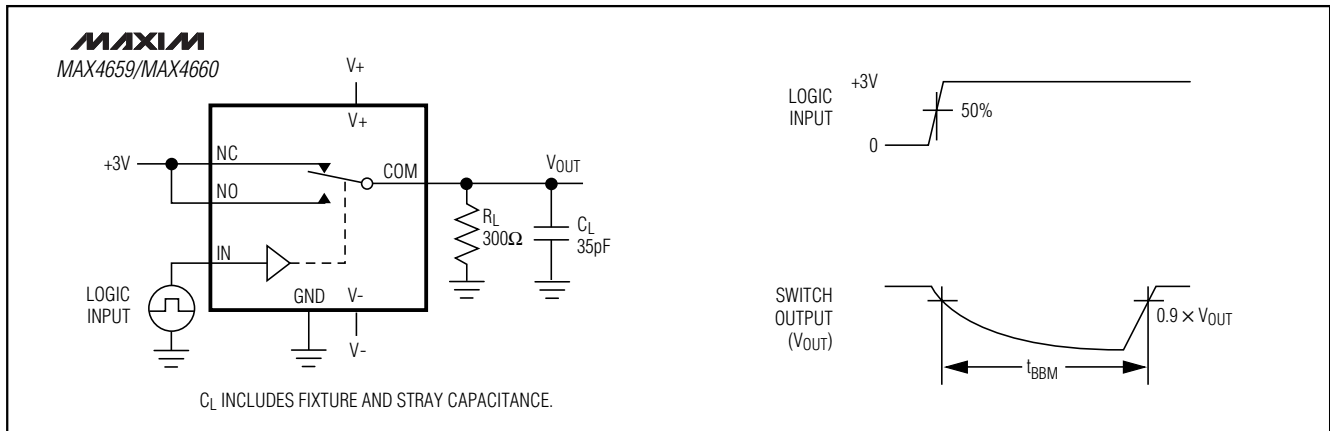

Figure 3. Break-Before-Make Time

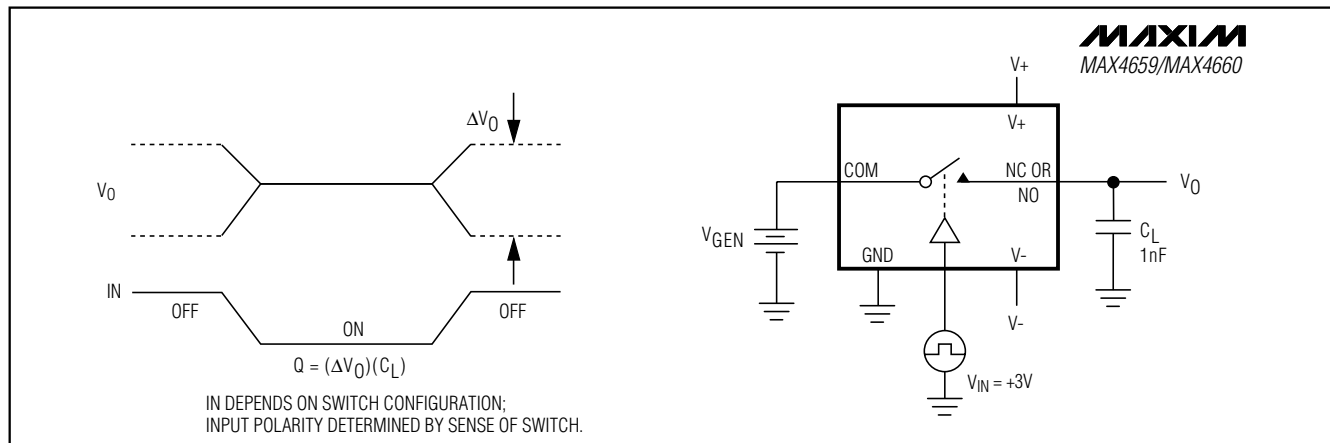

Figure 4. Charge Injection

High-Current, 25Ω, SPDT, CMOS Analog Switches

Test Circuits/Timing Diagrams (continued)

MAX4659/MAX4660

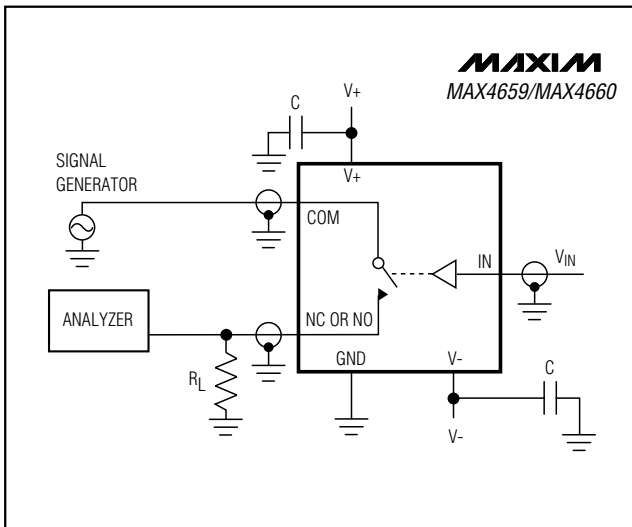

Figure 5. Off-Isolation

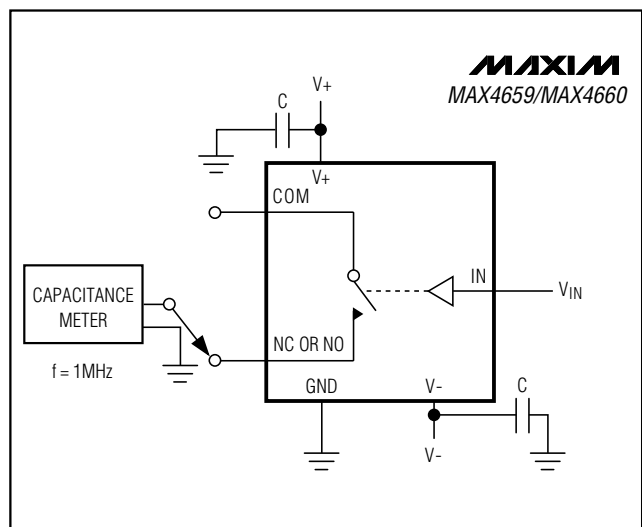

Figure 7. Channel Off-Capacitance

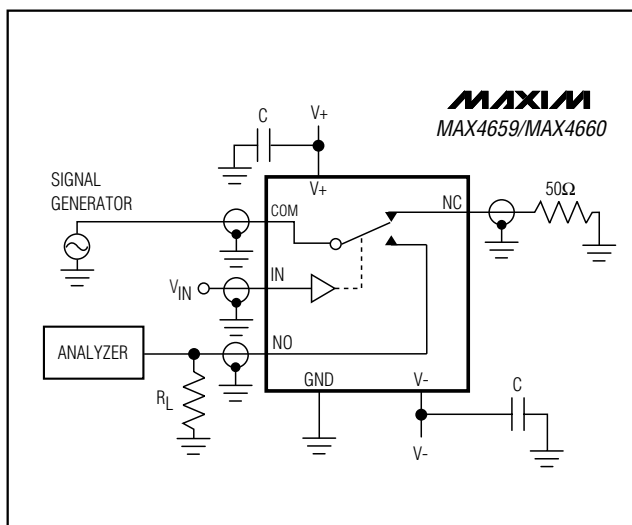

Figure 6. Crosstalk

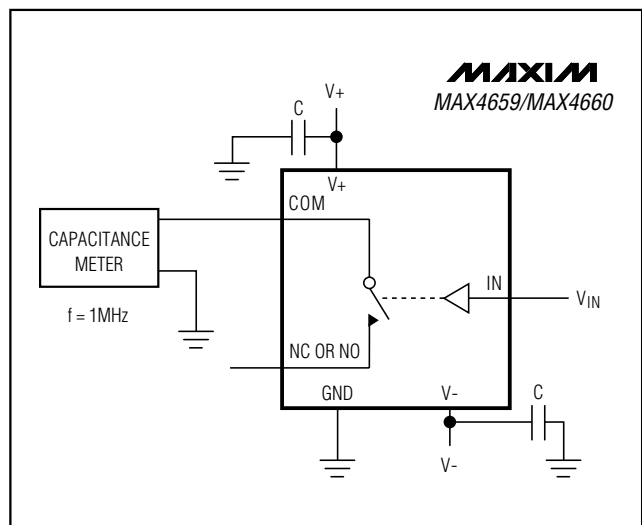

Figure 8. Channel On-Capacitance

Chip Information

TRANSISTOR COUNT: 45

PROCESS: CMOS

High-Current, 25Ω, SPDT, CMOS Analog Switches

Package Information

	INCHES		MILLIMETERS		JEDEC			
	MIN	MAX	MIN	MAX	INCHES	MAX	MIN	MAX
A	0.037	0.043	0.94	1.10	---	0.043	---	1.10
A1	0.002	0.006	0.05	0.15	0.002	0.006	0.05	0.15
B	0.010	0.014	0.25	0.36	0.010	0.016	0.25	0.40
C	0.005	0.007	0.13	0.18	0.005	0.009	0.13	0.23
D	0.116	0.120	2.95	3.05	0.114	0.122	2.9	3.1
e	0.0256	BSC	0.65	BSC	0.0256	BSC	0.64	BSC
E	0.116	0.120	2.95	3.05	0.114	0.122	2.9	3.1
H	0.188	0.198	4.78	5.03	0.193	BSC	4.9	BSC
L	0.016	0.026	0.41	0.66	0.016	0.027	0.40	0.70
α	0°	6°	0°	6°	0°	6°	0°	6°
*X	0.087	0.099	2.210	2.515				
*Y	0.062	0.074	1.575	1.880				

* EXPOSED PAD

8L, μMAX, EXP PAD, EPS

NOTES:
 1. D&E DO NOT INCLUDE MOLD FLASH.
 2. MOLD FLASH OR PROTRUSIONS NOT TO EXCEED 0.15MM (.006").
 3. CONTROLLING DIMENSION: MILLIMETERS.
 4. MEETS JEDEC MO-187.
 5. EXPOSED PAD FLUSH WITH BOTTOM OF PACKAGE WITHIN .002".

MAXIM

PROPRIETARY INFORMATION

TITLE:
PACKAGE OUTLINE, 8L μMAX, EXPOSED PAD

APPROVAL	DOCUMENT CONTROL NO. 21-0107	REV A	1/1
----------	---------------------------------	----------	-----

High-Current, 25Ω, SPDT, CMOS Analog Switches

Package Information (continued)

MAX4659/MAX4660

	INCHES		MILLIMETERS	
	MIN	MAX	MIN	MAX
A	0.053	0.069	1.35	1.75
A1	0.004	0.010	0.10	0.25
B	0.014	0.019	0.35	0.49
C	0.007	0.010	0.19	0.25
e	0.050		1.27	
E	0.150	0.157	3.80	4.00
H	0.228	0.244	5.80	6.20
h	0.010	0.020	0.25	0.50
L	0.016	0.050	0.40	1.27

	INCHES		MILLIMETERS		N	MS012
	MIN	MAX	MIN	MAX		
D	0.189	0.197	4.80	5.00	8	A
D	0.337	0.344	8.55	8.75	14	B
D	0.386	0.394	9.80	10.00	16	C

NOTES:
 1. D&E DO NOT INCLUDE MOLD FLASH
 2. MOLD FLASH OR PROTRUSIONS NOT TO EXCEED .15mm (.006")
 3. LEADS TO BE COPLANAR WITHIN .102mm (.004")
 4. CONTROLLING DIMENSION: MILLIMETER
 5. MEETS JEDEC MS012-XX AS SHOWN IN ABOVE TABLE
 6. N = NUMBER OF PINS

MAXIM
 121 SAN GABRIEL RD. SUNNYVALE CA 94086 FAX (408) 737 7794
 PROPRIETARY INFORMATION

PACKAGE FAMILY OUTLINE: SOIC .150" $\frac{1}{1}$ 21-0041 A
TITLE DOCUMENT CONTROL NUMBER REV

High-Current, 25Ω, SPDT, CMOS Analog Switches

Package Information (continued)

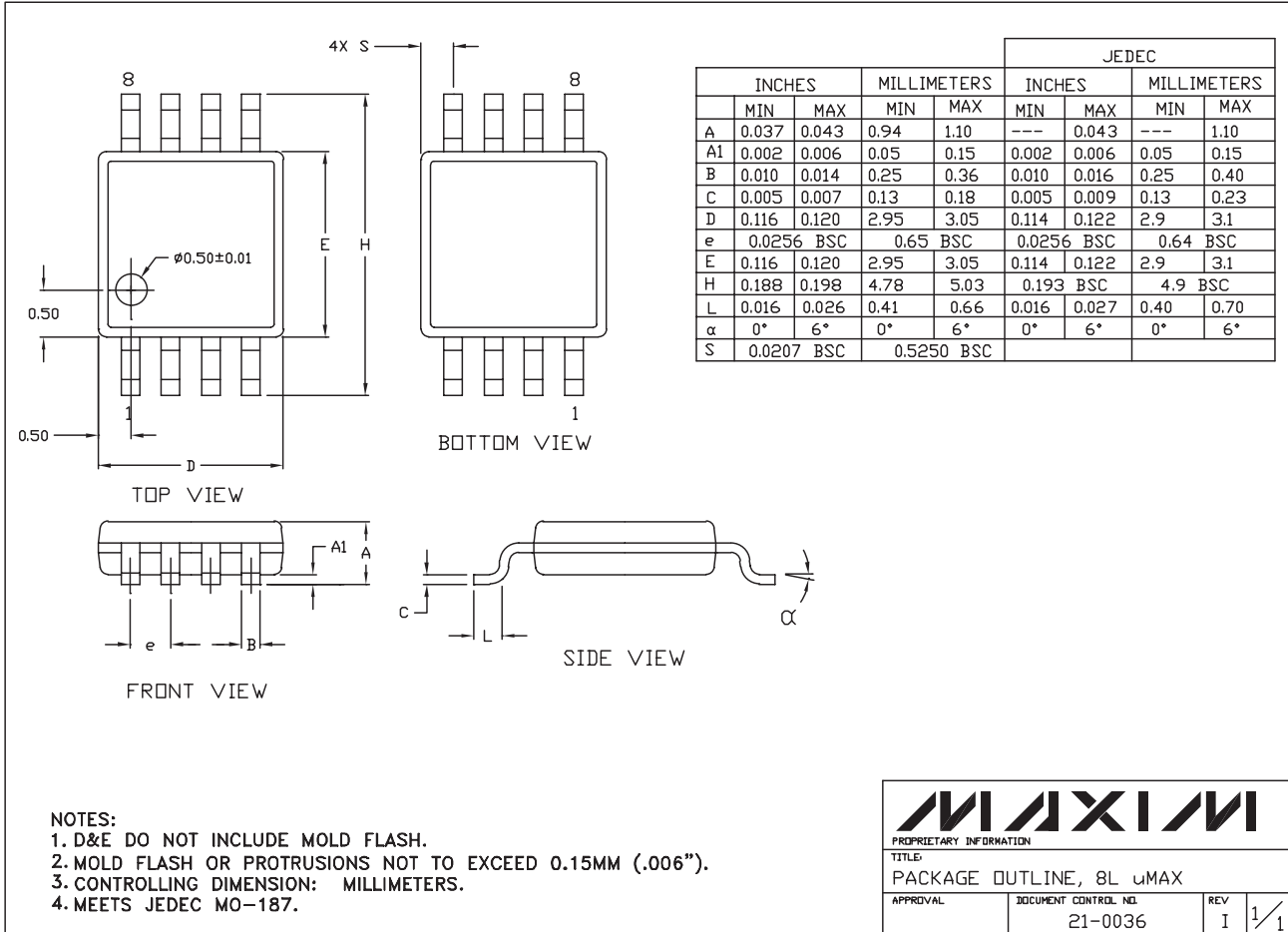

R1 (11/04/01) PDC

PROPRIETARY INFORMATION

TITLE:
PACKAGE OUTLINE, 8L uMAX

APPROVAL	DOCUMENT CONTROL NO. 21-0036	REV I	1/1
----------	---------------------------------	----------	-----

Maxim cannot assume responsibility for use of any circuitry other than circuitry entirely embodied in a Maxim product. No circuit patent licenses are implied. Maxim reserves the right to change the circuitry and specifications without notice at any time.

12 _____ **Maxim Integrated Products, 120 San Gabriel Drive, Sunnyvale, CA 94086 408-737-7600**