

## Features

- Serial Peripheral Interface (SPI) Compatible
- Supports SPI Modes 0 (0,0) and 3 (1,1)
- Data Sheet Describes Mode 0 Operation
- Low-voltage and Standard-voltage Operation
  - 2.7 ( $V_{CC} = 2.7V$  to 5.5V)
  - 1.8 ( $V_{CC} = 1.8V$  to 5.5V)
- 20 MHz Clock Rate (5V)
- 64-byte Page Mode and Byte Write Operation
- Block Write Protection
  - Protect 1/4, 1/2, or Entire Array
- Write Protect ( $\overline{WP}$ ) Pin and Write Disable Instructions for Both Hardware and Software Data Protection
- Self-timed Write Cycle (5 ms Max)
- High-reliability
  - Endurance: 1 Million Write Cycles
  - Data Retention: >100 Years
- 8-lead PDIP, 8-lead EIAJ SOIC, 8-lead JEDEC SOIC, 8-lead TSSOP, 8-ball dBGAA2 and 8-lead Ultra Thin SAP Packages
- Lead-free/Halogen-free
- Available in Automotive
- Die Sales: Wafer Form, Waffle Pack, and Bumped Die

## Description

The AT25128A/256A provides 131,072/262,144 bits of serial electrically-erasable programmable read only memory (EEPROM) organized as 16,384/32,768 words of 8 bits each. The device is optimized for use in many industrial and commercial applications where low-power and low-voltage operation are essential. The devices are available in space saving 8-lead PDIP, 8-lead EIAJ SOIC, 8-lead JEDEC SOIC, 8-lead TSSOP, 8-ball dBGAA2 and 8-lead SAP packages. In addition, the entire family is available in 2.7V (2.7V to 5.5V) and 1.8V (1.8V to 5.5V) versions.

The AT25128A/256A is enabled through the Chip Select pin ( $\overline{CS}$ ) and accessed via a 3-wire interface consisting of Serial Data Input (SI), Serial Data Output (SO), and Serial Clock (SCK). All programming cycles are completely self-timed, and no separate Erase cycle is required before Write.

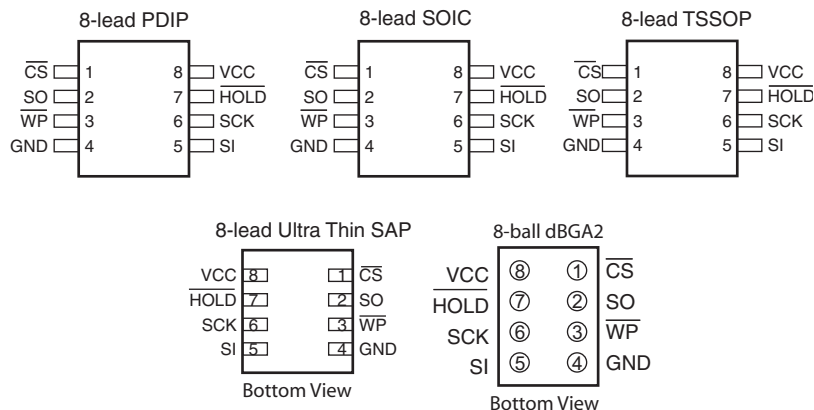

## SPI Serial EEPROMs

128K (16,384 x 8)

256K (32,768 x 8)

## AT25128A AT25256A



**Table 0-1. Pin Configurations**

Pin Name	Function
$\overline{CS}$	Chip Select
SCK	Serial Data Clock
SI	Serial Data Input
SO	Serial Data Output
GND	Ground
VCC	Power Supply
$\overline{WP}$	Write Protect
$\overline{HOLD}$	Suspends Serial Input
NC	No Connect

Block Write protection is enabled by programming the status register with top ¼, top ½ or entire array of write protection. Separate Program Enable and Program Disable instructions are provided for additional data protection. Hardware data protection is provided via the  $\overline{WP}$  pin to protect against inadvertent write attempts to the status register. The  $\overline{HOLD}$  pin may be used to suspend any serial communication without resetting the serial sequence.

## 1. Absolute Maximum Ratings\*

Operating Temperature .....	-55°C to +125°C
Storage Temperature .....	-65°C to +150°C
Voltage on Any Pin with Respect to Ground .....	-1.0V to +7.0V
Maximum Operating Voltage .....	6.25V
DC Output Current.....	5.0 mA

\*NOTICE: Stresses beyond those listed under “Absolute Maximum Ratings” may cause permanent damage to the device. This is a stress rating only and functional operation of the device at these or any other conditions beyond those indicated in the operational sections of this specification is not implied. Exposure to absolute maximum rating conditions for extended periods may affect device reliability.

**Figure 1-1.** Block Diagram

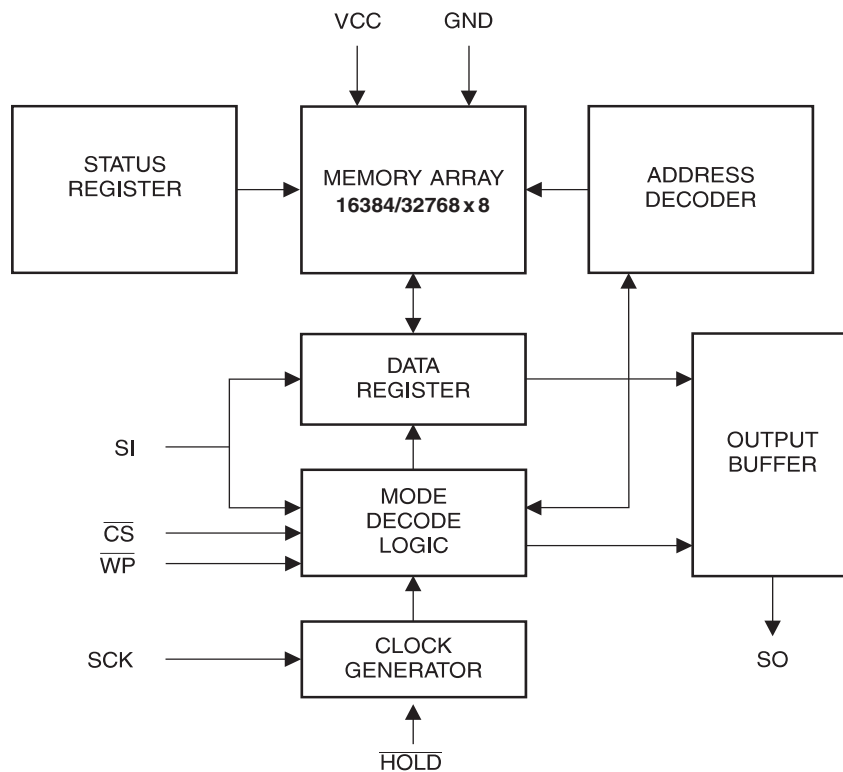

**Table 1-1.** Pin Capacitance<sup>(1)</sup>

Applicable over recommended operating range from  $T_A = 25^\circ\text{C}$ ,  $f = 1.0\text{ MHz}$ ,  $V_{CC} = +5.0\text{V}$  (unless otherwise noted)

Symbol	Test Conditions	Max	Units	Conditions
$C_{OUT}$	Output Capacitance (SO)	8	pF	$V_{OUT} = 0\text{V}$
$C_{IN}$	Input Capacitance ( $\overline{CS}$ , SCK, SI, $\overline{WP}$ , $\overline{HOLD}$ )	6	pF	$V_{IN} = 0\text{V}$

Note: 1. This parameter is characterized and is not 100% tested.

**Table 1-2. DC Characteristics**

Applicable over recommended operating range from  $T_{AI} = -40^{\circ}\text{C}$  to  $+85^{\circ}\text{C}$ ,  $V_{CC} = +1.8\text{V}$  to  $+5.5\text{V}$ ,  
 $T_{AE} = -40^{\circ}\text{C}$  to  $+125^{\circ}\text{C}$ ,  $V_{CC} = +1.8\text{V}$  to  $+5.5\text{V}$  (unless otherwise noted)

Symbol	Parameter	Test Condition	Min	Typ	Max	Units
$V_{CC1}$	Supply Voltage		1.8		5.5	V
$V_{CC2}$	Supply Voltage		2.7		5.5	V
$V_{CC3}$	Supply Voltage		4.5		5.5	V
$I_{CC1}$	Supply Current	$V_{CC} = 5.0\text{V}$ at 20 MHz, SO = Open, Read		9.0	10.0	mA
$I_{CC2}$	Supply Current	$V_{CC} = 5.0\text{V}$ at 10 MHz, SO = Open, Read, Write		5.0	7.0	mA
$I_{CC3}$	Supply Current	$V_{CC} = 5.0\text{V}$ at 1 MHz, SO = Open, Read, Write		2.2	3.5	mA
$I_{SB1}$	Standby Current	$V_{CC} = 1.8\text{V}$ , $\overline{CS} = V_{CC}$		0.2	3.0	$\mu\text{A}$
$I_{SB2}$	Standby Current	$V_{CC} = 2.7\text{V}$ , $\overline{CS} = V_{CC}$		0.5	3.0	$\mu\text{A}$
$I_{SB3}$	Standby Current	$V_{CC} = 5.0\text{V}$ , $\overline{CS} = V_{CC}$		2.0	5.0	$\mu\text{A}$
$I_{IL}$	Input Leakage	$V_{IN} = 0\text{V}$ to $V_{CC}$	-3.0		3.0	$\mu\text{A}$
$I_{OL}$	Output Leakage	$V_{IN} = 0\text{V}$ to $V_{CC}$ , $T_{AC} = 0^{\circ}\text{C}$ to $70^{\circ}\text{C}$	-3.0		3.0	$\mu\text{A}$
$V_{IL}^{(1)}$	Input Low-voltage		-1.0		$V_{CC} \times 0.3$	V
$V_{IH}^{(1)}$	Input High-voltage		$V_{CC} \times 0.7$		$V_{CC} + 0.5$	V
$V_{OL1}$	Output Low-voltage	$3.6 \leq V_{CC} \leq 5.5\text{V}$			0.4	V
$V_{OH1}$	Output High-voltage		$I_{OL} = 3.0\text{ mA}$	$I_{OH} = -1.6\text{ mA}$	$V_{CC} - 0.8$	V
$V_{OL2}$	Output Low-voltage	$1.8\text{V} \leq V_{CC} \leq 3.6\text{V}$			0.2	V
$V_{OH2}$	Output High-voltage		$I_{OL} = 0.15\text{ mA}$	$I_{OH} = -100\text{ }\mu\text{A}$	$V_{CC} - 0.2$	V

Note: 1.  $V_{IL}$  min and  $V_{IH}$  max are reference only and are not tested.

**Table 1-3.** AC Characteristics

Applicable over recommended operating range from  $T_{AI} = -40^{\circ}\text{C}$  to  $+85^{\circ}\text{C}$ ,  $T_{AE} = -40^{\circ}\text{C}$  to  $+125^{\circ}\text{C}$ ,  $V_{CC} = \text{As Specified}$ ,  $CL = 1$  TTL Gate and  $30\text{ pF}$  (unless otherwise noted)

Symbol	Parameter	Voltage	Min	Max	Units
$f_{SCK}$	SCK Clock Frequency	4.5–5.5	0	20	MHz
		2.7–5.5	0	10	
		1.8–5.5	0	5	
$t_{RI}$	Input Rise Time	4.5–5.5		2	$\mu\text{s}$
		2.7–5.5		2	
		1.8–5.5		2	
$t_{FI}$	Input Fall Time	4.5–5.5		2	$\mu\text{s}$
		2.7–5.5		2	
		1.8–5.5		2	
$t_{WH}$	SCK High Time	4.5–5.5	20		ns
		2.7–5.5	40		
		1.8–5.5	80		
$t_{WL}$	SCK Low Time	4.5–5.5	20		ns
		2.7–5.5	40		
		1.8–5.5	80		
$t_{CS}$	$\overline{CS}$ High Time	4.5–5.5	100		ns
		2.7–5.5	100		
		1.8–5.5	200		
$t_{CSS}$	$\overline{CS}$ Setup Time	4.5–5.5	100		ns
		2.7–5.5	100		
		1.8–5.5	200		
$t_{CSH}$	$\overline{CS}$ Hold Time	4.5–5.5	100		ns
		2.7–5.5	100		
		1.8–5.5	200		
$t_{SU}$	Data In Setup Time	4.5–5.5	5		ns
		2.7–5.5	10		
		1.8–5.5	20		
$t_H$	Data In Hold Time	4.5–5.5	5		ns
		2.7–5.5	10		
		1.8–5.5	20		
$t_{HD}$	$\overline{Hold}$ Setup Time	4.5–5.5	5		ns
		2.7–5.5	10		
		1.8–5.5	20		
$t_{CD}$	$\overline{Hold}$ Hold Time	4.5–5.5	5		ns
		2.7–5.5	10		
		1.8–5.5	20		
$t_V$	Output Valid	4.5–5.5	0	20	ns
		2.7–5.5	0	40	
		1.8–5.5	0	80	
$t_{HO}$	Output Hold Time	4.5–5.5	0		ns
		2.7–5.5	0		
		1.8–5.5	0		
$t_{LZ}$	$\overline{Hold}$ to Output Low Z	4.5–5.5	0	25	ns
		2.7–5.5	0	50	
		1.8–5.5	0	100	

**Table 1-3. AC Characteristics (Continued)**

Applicable over recommended operating range from  $T_{AI} = -40^{\circ}\text{C}$  to  $+85^{\circ}\text{C}$ ,  $T_{AE} = -40^{\circ}\text{C}$  to  $+125^{\circ}\text{C}$ ,  $V_{CC} = \text{As Specified}$ ,  $CL = 1$  TTL Gate and  $30\text{ pF}$  (unless otherwise noted)

Symbol	Parameter	Voltage	Min	Max	Units
$t_{HZ}$	$\overline{\text{Hold}}$ to Output High Z	4.5–5.5 2.7–5.5 1.8–5.5		25 50 100	ns
$t_{DIS}$	Output Disable Time	4.5–5.5 2.7–5.5 1.8–5.5		25 50 100	ns
$t_{WC}$	Write Cycle Time	4.5–5.5 2.7–5.5 1.8–5.5		5 5 5	ms
Endurance <sup>(1)</sup>	5.0V, 25°C, Page Mode		1M		Write Cycles

Notes: 1. This parameter is characterized and is not 100% tested. Contact Atmel for further information.



## AT25256A Ordering Information<sup>(1)</sup>

Ordering Code	Package	Operation Range
AT25256A-10PU-2.7 <sup>(2)</sup>	8P3	Lead-free/Halogen-free/ Industrial Temperature (-40°C to 85°C)
AT25256A-10PU-1.8 <sup>(2)</sup>	8P3	
AT25256AN-10SU-2.7 <sup>(2)</sup>	8S1	
AT25256AN-10SU-1.8 <sup>(2)</sup>	8S1	
AT25256AW-10SU-2.7 <sup>(2)</sup>	8S2	
AT25256AW-10SU-1.8 <sup>(2)</sup>	8S2	
AT25256A-10TU-2.7 <sup>(2)</sup>	8A2	
AT25256A-10TU-1.8 <sup>(2)</sup>	8A2	
AT25256AU2-10UU-1.8 <sup>(2)</sup>	8U2-1	
AT25256AY7-10YH-1.8 <sup>(2)</sup>	8Y7	
AT25256A-W1.8-11 <sup>(3)</sup>	Die Sale	Industrial Temperature (-40°C to 85°C)

- Notes:
1. For 2.7V devices used in the 4.5V to 5.5V range, please refer to performance values in the AC and DC Characteristics tables.
  2. "U" designates Green package + RoHS compliant.
  3. Available in waffle pack and wafer form; order as SL788 for wafer form. Bumped die available upon request. Please contact Serial Interface Marketing.

Package Type	
<b>8P3</b>	8-lead, 0.300" Wide, Plastic Dual In-line Package (PDIP)
<b>8S1</b>	8-lead, 0.150" Wide, Plastic Gull Wing Small Outline Package (JEDEC SOIC)
<b>8S2</b>	8-lead, 0.200" Wide, Plastic Gull Wing Small Outline Package (EIAJ SOIC)
<b>8U2-1</b>	8-ball, die Ball Grid Array Package (dBGAA2)
<b>8A2</b>	8-lead, 4.4 mm Body, Thin Shrink Small Outline Package (TSSOP)
<b>8Y7</b>	8-lead, 6.00 mm x 4.90 mm Body, Ultra Thin, Dual Footprint, Non-leaded, Small Array Package (SAP)
Options	
<b>-2.7</b>	Low-voltage (2.7V to 5.5V)
<b>-1.8</b>	Low-voltage (1.8V to 5.5V)

8S2 – EIAJ SOIC

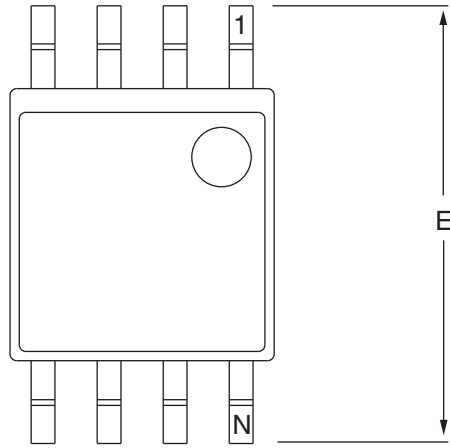

Top View

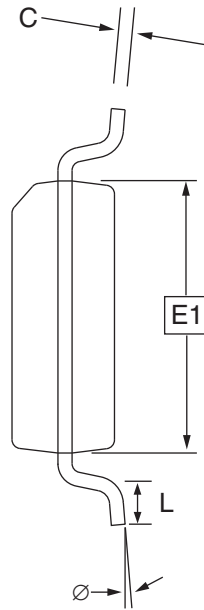

End View

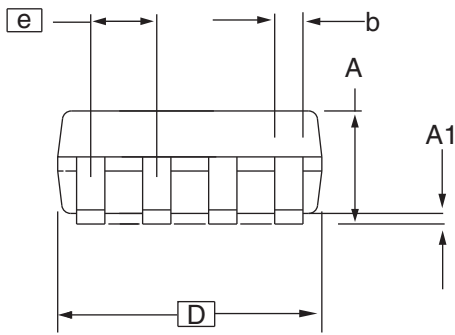

Side View

COMMON DIMENSIONS  
(Unit of Measure = mm)

SYMBOL	MIN	NOM	MAX	NOTE
A	1.70		2.16	
A1	0.05		0.25	
b	0.35		0.48	5
C	0.15		0.35	5
D	5.13		5.35	
E1	5.18		5.40	2, 3
E	7.70		8.26	
L	0.51		0.85	
Ø	0°		8°	
e	1.27 BSC			4

- Notes: 1. This drawing is for general information only; refer to EIAJ Drawing EDR-7320 for additional information.  
 2. Mismatch of the upper and lower dies and resin burrs are not included.  
 3. It is recommended that upper and lower cavities be equal. If they are different, the larger dimension shall be regarded.  
 4. Determines the true geometric position.  
 5. Values b and C apply to pb/Sn solder plated terminal. The standard thickness of the solder layer shall be 0.010 +0.010/-0.005 mm.

**ATMEL** 2325 Orchard Parkway  
San Jose, CA 95131

**TITLE**  
8S2, 8-lead, 0.209" Body, Plastic Small  
Outline Package (EIAJ)

**DRAWING NO.**  
8S2

**REV.**  
C