

32-Channel Serial to Parallel Converter With High Voltage Push-Pull Outputs

Features

- ▶ Processed with HVCMOS® technology
- ▶ Output voltages up to 80V
- ▶ Low power level shifting
- ▶ Shift register speed 8.0MHz
- ▶ Latched data outputs
- ▶ 5.0V CMOS compatible inputs
- ▶ Forward and reverse shifting options
- ▶ Diode to V_{pp} allows efficient power recovery

General Description

The HV9808 is a low voltage serial to high voltage parallel converters with push-pull outputs. This device has been designed for use as a driver for AC-electroluminescent displays. It can also be used in any application requiring multiple output, high voltage current sourcing and sinking capabilities such as driving plasma panels, vacuum fluorescent, or large matrix LCD displays. The inputs are fully CMOS compatible.

This device consists of a 32-bit shift register, 32 latches, and control logic to perform the polarity select and blanking of the outputs. HV_{OUT1} is connected to the first stage of the shift register through the polarity and blanking logic. Data is shifted through the shift register on the logic low to high transition of the clock. The HV9808 shifts data in the counter-clockwise direction when viewed from the top of the package. A data output buffer is provided for cascading devices. This output reflects the current status of the last bit of the shift register (HV_{OUT32}). Operation of the shift register is not affected by the \overline{LE} (latch enable), \overline{BL} (blanking), or the \overline{POL} (polarity) in-puts. Transfer of data from the shift register to the latch occurs when the \overline{LE} (latch enable) input is high. The data in the latch is stored when \overline{LE} is low.

Block Diagram

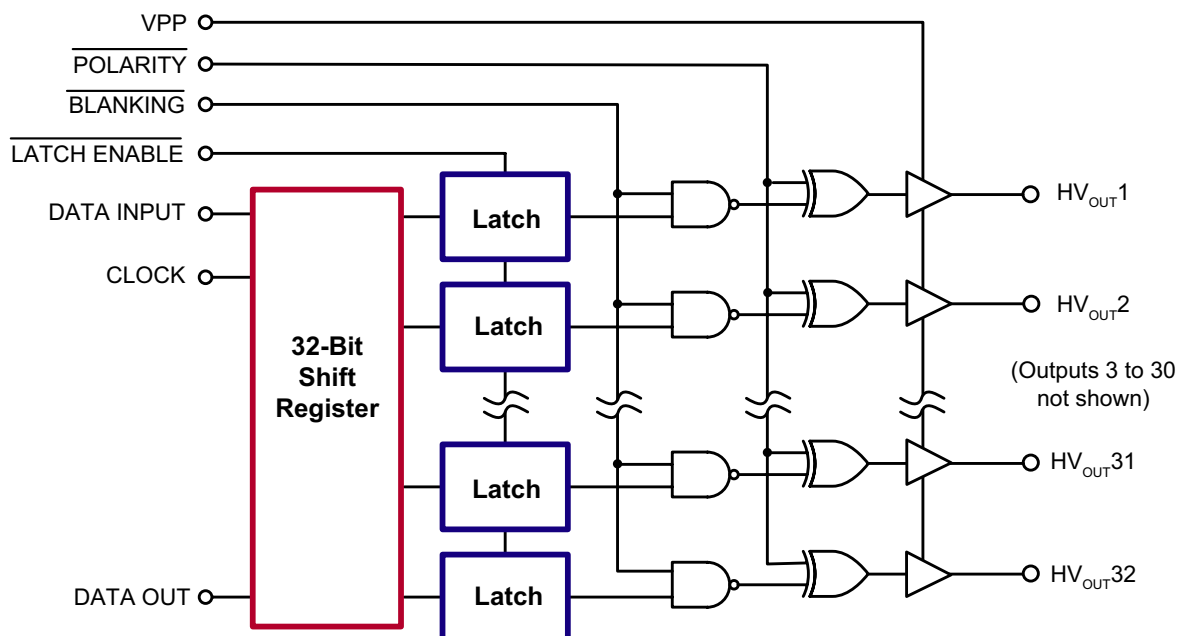

Ordering Information

Device	Package Options
	44-Lead Quad Plastic Chip Carrier .653x.653in body .180in height (max) .050in pitch
HV9808	HV9808PJ-G

-G indicates package is RoHS compliant ("Green")



Absolute Maximum Ratings

Parameter	Value
Supply voltage, V_{DD}	-0.5V to +7.0V
Supply voltage, V_{PP}	-0.5V to +90V
Logic input levels	-0.5V to $V_{DD} + 0.5V$
Ground current ¹	1.5A
Continuous total power dissipation ²	1200mW
Operating temperature range	-40 to +85°C
Storage temperature range	-65 to +150°C

Absolute Maximum Ratings are those values beyond which damage to the device may occur. Functional operation under these conditions is not implied. Continuous operation of the device at the absolute rating level may affect device reliability. All voltages are referenced to device ground.

Notes:

- Duty cycle is limited by the total power dissipated in the package.
- For operation above 25°C ambient derate linearly to maximum operating temperature at 20mW/°C.

Recommended Operating Conditions

Sym	Parameter	Min	Max	Units
V_{DD}	Logic voltage supply	4.5	5.5	V
V_{PP}	High voltage supply	8.0	80	V
V_{IH}	Input high voltage	$V_{DD} - 0.5$	V_{DD}	V
V_{IL}	Input low voltage	0	0.5	V
f_{CLK}	Clock frequency	0	8.0	MHz
T_A	Operating free-air temperature	-40	+85	°C

Pin Configuration

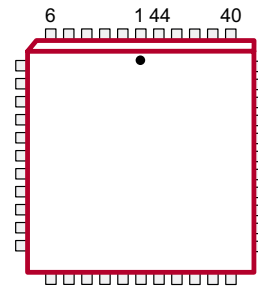

44-Lead Quad Plastic Chip Carrier (PJ)

Product Marking

Top Marking



YY = Year Sealed
 WW = Week Sealed
 L = Lot Number
 A = Assembler ID
 C = Country of Origin*
 — = "Green" Packaging
 *May be part of top marking

Bottom Marking

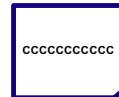

Package may or may not include the following marks: Si or

44-Lead Quad Plastic Chip Carrier (PJ)

Electrical Characteristics ($V_{PP} = 60V$, $V_{DD} = 5.0V$, $T_A = 25^\circ C$)

DC Characteristics

Sym	Parameter	Min	Max	Units	Conditions
I_{PP}	V_{PP} supply current	-	100	μA	HV _{OUTPUTS} high to low
I_{DDQ}	I_{DD} supply current (quiescent)	-	100	μA	All inputs = V_{DD} or GND
I_{DD}	I_{DD} supply current (operating)	-	15	mA	$V_{DD} = V_{DD} \text{ max}$, $f_{CLK} = 8.0 \text{ MHz}$
V_{OH} (Data)	Shift register output voltage	$V_{DD} - 0.5$	-	V	$I_O = -100\mu A$
V_{OL} (Data)	Shift register output voltage	-	0.5	V	$I_O = 100\mu A$
I_{IH}	Current leakage, any input	-	1.0	μA	Input = V_{DD}
I_{IL}	Current leakage, any input	-	-1.0	μA	Input = GND
V_{OC}	HV output clamp diode voltage	-	-1.5	V	$I_{OC} = -5.0 \text{ mA}$
V_{OH}	HV output when sourcing	52	-	V	$I_{OH} = -20 \text{ mA}$, 0 to $70^\circ C$
V_{OL}	HV output when sinking	-	4.0	V	$I_{OL} = 5.0 \text{ mA}$, 0 to $70^\circ C$

AC Characteristics

Sym	Parameter	Min	Max	Units	Conditions
f_{CLK}	Clock frequency	-	8.0	MHz	---
t_{WL} or t_{WH}	Clock width, high or low	62	-	ns	---
t_{SU}	Setup time before CLK rises	25	-	ns	---
t_H	Hold time after CLK rises	10	-	ns	---
t_{DLH} (Data)	Data output delay after L to H CLK	-	110	ns	CL = 15pF
t_{DHL} (Data)	Data output delay after H to L CLK	-	110	ns	CL = 15pF
t_{DLE}	\overline{LE} delay after L to H CLK	50	-	ns	---
t_{WLE}	Width of \overline{LE} pulse	50	-	ns	---
t_{SLE}	\overline{LE} setup time before L to H CLK	50	-	ns	---
t_{ON}	Delay from \overline{LE} to HV _{OUT} , L to H	-	500	ns	---
t_{OFF}	Delay from \overline{LE} to HV _{OUT} , H to L	-	500	ns	---

Power-Up Sequence

1. Connect ground
2. Apply V_{DD}
3. Set all inputs (Data, CLK, Enable, etc.) to a known state
4. Apply V_{PP}

Power-down sequence should be the reverse of the above.

The V_{PP} should not drop below V_{DD} during operations.

Input and Output Equivalent Circuits

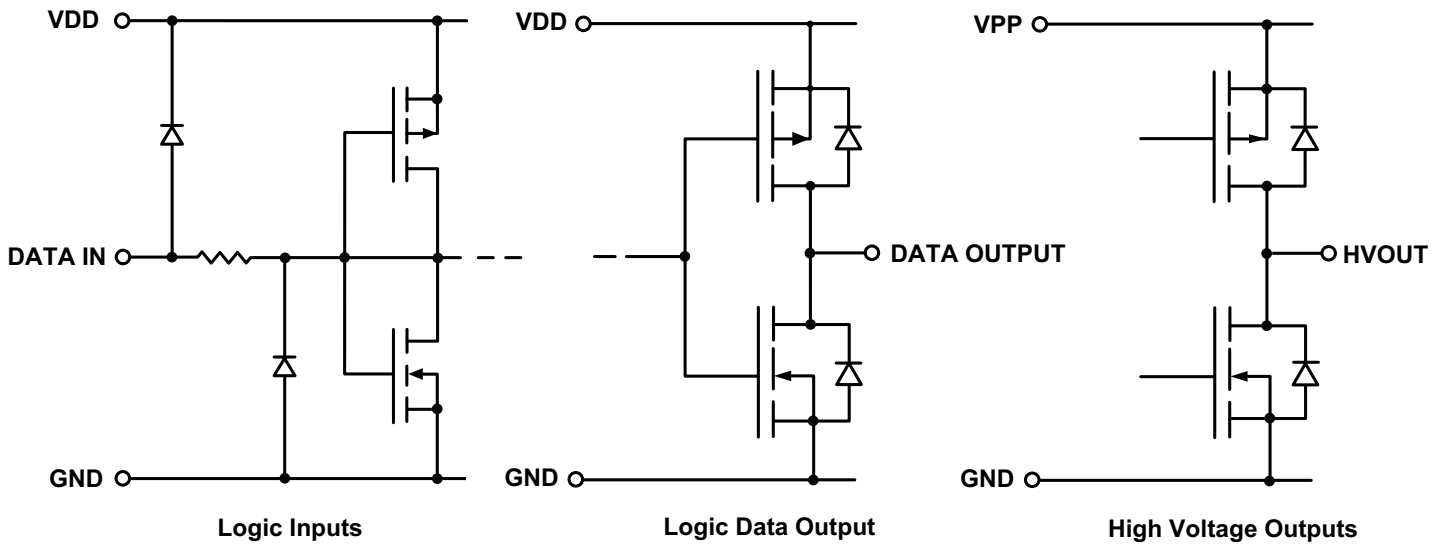

Switching Waveforms

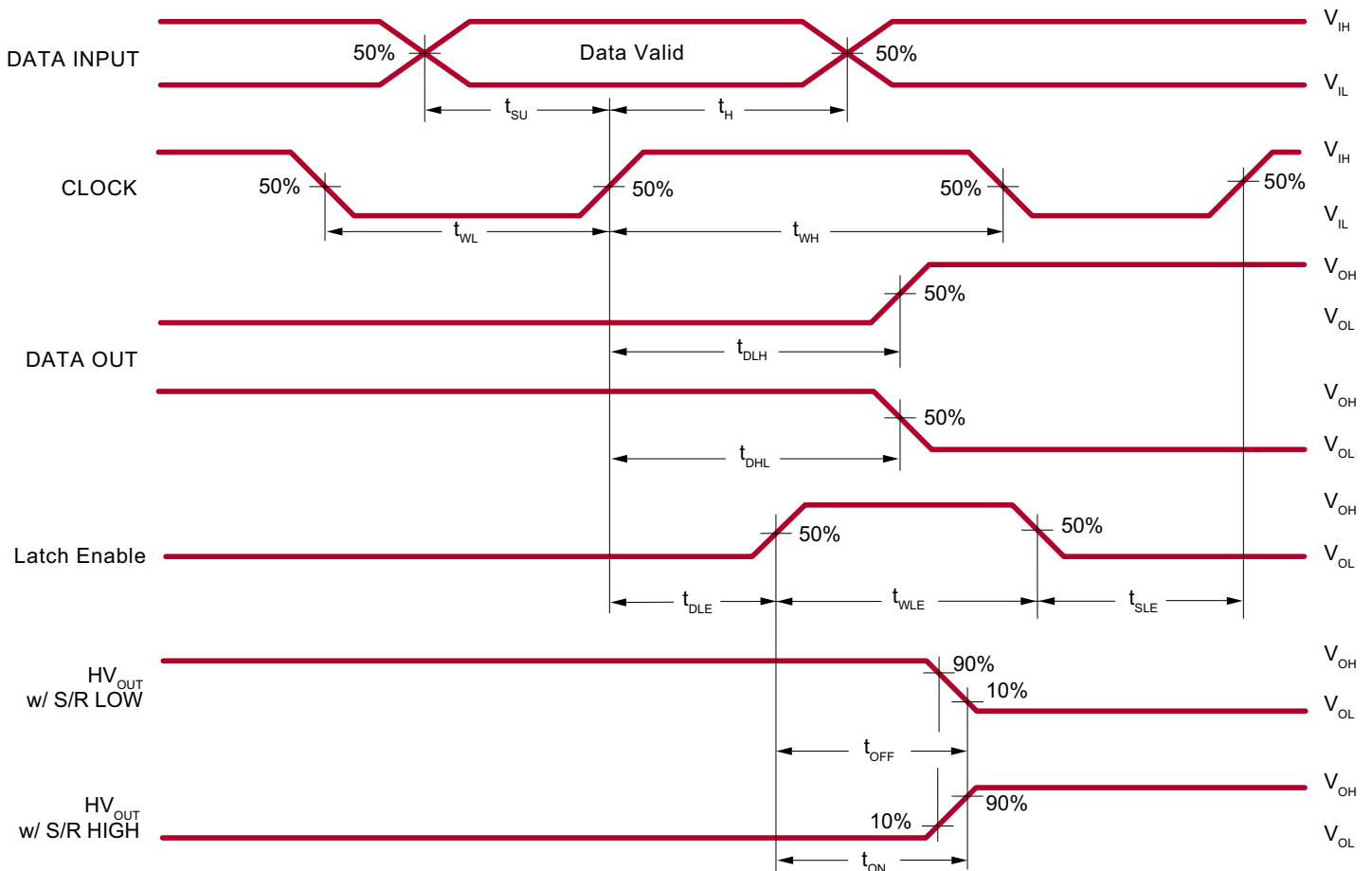

Function Table

Function	Inputs					Outputs		
	Data	CLK	\overline{LE}	\overline{BL}	\overline{POL}	Shift Reg 1 2...8	HV Outputs 1 2...8	Data Out •
All on	X	X	X	L	L	• •...•	H H...H	•
All off	X	X	X	L	H	• •...•	L L...L	•
Invert mode	X	X	L	H	L	• •...•	$\overline{\bullet}$ $\overline{\bullet}$... $\overline{\bullet}$	•
Load S/R	H OR L	↑	L	H	H	H or L •...•	• •...•	•
Load latches	X	X	↑	H	H	• •...•	• •...•	•
	X	X	↑	H	L	• •...•	$\overline{\bullet}$ $\overline{\bullet}$... $\overline{\bullet}$	•
Transparent latch mode	L	↑	H	H	H	L •...•	L •...•	•
	H	↑	H	H	H	H •...•	H •...•	•

Notes:

H = high level, L = low level, X = irrelevant, ↑ = low-to-high transition
 • = dependent on previous stage's state before the last CLK or last \overline{LE} high.

Pin Description

Pin	Function	Function
1	HV _{OUT} 16	High voltage outputs. High voltage push-pull outputs, which, depending on controlling low voltage data, can drive loads either to a GND, or to V _{pp} rail levels.
2	HV _{OUT} 17	
3	HV _{OUT} 18	
4	HV _{OUT} 19	
5	HV _{OUT} 20	
6	HV _{OUT} 21	
7	HV _{OUT} 22	
8	HV _{OUT} 23	
9	HV _{OUT} 24	
10	HV _{OUT} 25	
11	HV _{OUT} 26	
12	HV _{OUT} 27	
13	HV _{OUT} 28	
14	HV _{OUT} 29	
15	HV _{OUT} 30	
16	HV _{OUT} 31	
17	HV _{OUT} 32	
18	Data Out	Serial data output Data output for cascading to the data input of the next device.

Pin Description (cont.)

Pin	Function	Function
19	N/C	No connect.
20	N/C	
21	$\overline{\text{Polarity}}$	---
22	CLK	Data shift register clock. Input are shifted into the shift register on the positive edge of the clock.
23	GND	Logic and high voltage ground.
24	VPP	High voltage power rail.
25	VDD	Low voltage logic power rail.
26	$\overline{\text{Latch Enable}}$	Latch enable input. When $\overline{\text{LE}}$ is high, shift register data is transferred into a data latch. When $\overline{\text{LE}}$ is low, data is latched, and new data can be clocked into the shift register.
27	Data In	Serial data input. Data needs to be present before each rising edge of the clock.
28	$\overline{\text{Blanking}}$	---
29	N/C	No connect.
30	HV _{OUT1}	High voltage outputs. High voltage push-pull outputs, which, depending on controlling low voltage data, can drive loads either to a GND, or to V _{PP} rail levels.
31	HV _{OUT2}	
32	HV _{OUT3}	
33	HV _{OUT4}	
34	HV _{OUT5}	
35	HV _{OUT6}	
36	HV _{OUT7}	
37	HV _{OUT8}	
38	HV _{OUT9}	
39	HV _{OUT10}	
40	HV _{OUT11}	
41	HV _{OUT12}	
42	HV _{OUT13}	
43	HV _{OUT14}	
44	HV _{OUT15}	

44-Lead PLCC Package Outline (PJ)

.653x.653in body, .180in height (max), .050in pitch

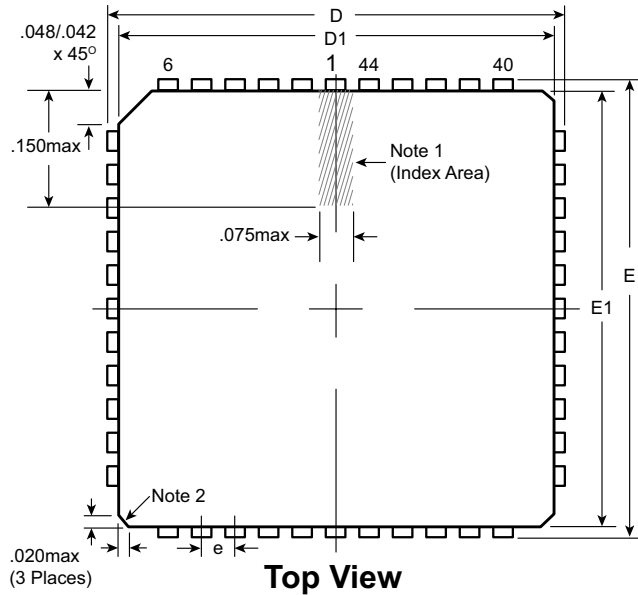

Top View

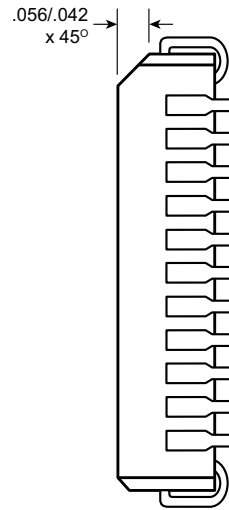

Vertical Side View

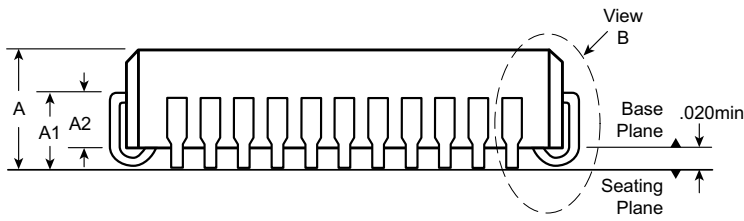

Horizontal Side View

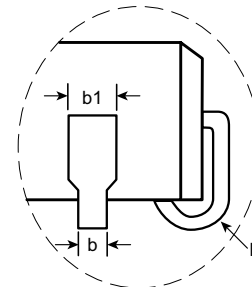

View B

Notes:

1. A Pin 1 identifier must be located in the index area indicated. The Pin 1 identifier can be: a molded mark/identifier; an embedded metal marker; or a printed indicator.
2. Actual shape of this feature may vary.

Symbol	A	A1	A2	b	b1	D	D1	E	E1	e	R	
Dimension (inches)	MIN	.165	.090	.062	.013	.026	.685	.650	.685	.650	.050 BSC	.025
	NOM	.172	.105	-	-	-	.690	.653	.690	.653		.035
	MAX	.180	.120	.083	.021	.036 [†]	.695	.656	.695	.656		.045

JEDEC Registration MS-018, Variation AC, Issue A, June, 1993.

[†] This dimension differs from the JEDEC drawing.

Drawings not to scale.

Supertex Doc. #: DSPD-44PLCCPJ, Version F031111.

(The package drawing(s) in this data sheet may not reflect the most current specifications. For the latest package outline information go to <http://www.supertex.com/packaging.html>.)

Supertex inc. does not recommend the use of its products in life support applications, and will not knowingly sell them for use in such applications unless it receives an adequate "product liability indemnification insurance agreement." **Supertex inc.** does not assume responsibility for use of devices described, and limits its liability to the replacement of the devices determined defective due to workmanship. No responsibility is assumed for possible omissions and inaccuracies. Circuitry and specifications are subject to change without notice. For the latest product specifications refer to the **Supertex inc.** (website: <http://www.supertex.com>)