



MIC23303 Evaluation Board

4MHz PWM 3A Buck Regulator with
Hyper Light Load[®] and Power Good

General Description

This board allows the customer to evaluate the MIC23303, a fully integrated 3A, 4MHz switching regulator that features Hyper Light Load[®] mode, a Power Good output indicator, and programmable soft-start. The MIC23303 is highly efficient throughout the output current range, drawing just 24 μ A of quiescent current in operation. The tiny 3mm x 3mm DFN package, in combination with the 4MHz switching frequency, creates a compact sub-1mm height solution with only six external components. The MIC23303 provides accurate output voltage regulation under the most demanding conditions and responds extremely quickly to a load transient with exceptionally small output voltage ripple.

Requirements

This board needs a single 10W bench power source adjustable from 2.9V to 5.5V. The loads can be either active (electronic load) or passive (resistor), and must be able to dissipate 10W. It is ideal, but not essential, to have an oscilloscope available to view the circuit waveforms. The simplest tests require two voltage meters to measure input and output voltage. Efficiency measurements require two voltage meters and two ammeters to prevent errors caused by measurement inaccuracies.

Precautions

There is no reverse input protection on this board. Be careful when connecting the input source to make sure correct polarity is observed.

Data sheets and support documentation can be found on Micrel's web site at www.micrel.com.

Getting Started

1. **Connect an external supply to the V_{IN} (J1) terminal and GND (J6).** With the output of the power supply disabled, set its voltage to the desired input test voltage ($2.9V \leq V_{IN} \leq 5.5V$). The user can place an ammeter between the input supply and the V_{IN} (J1) terminal. Be sure to monitor the supply voltage at the V_{IN} (J1) terminal, as the ammeter and/or power lead resistance can reduce the voltage supplied to the device.
2. **Connect a load to the V_{OUT} (J5) and ground (J2) terminals.** The load can be either active passive (resistive) or active (electronic load). The user can place an ammeter between the load and the output terminal. Make sure the output voltage is monitored at the V_{OUT} (J5) terminal. The board has a 2-pin connector (JP1) to allow for output voltage monitoring.
3. **Enable the MIC23303.** The MIC23303 evaluation board has a pull-up resistor to V_{IN} . By default, the output voltage is enabled when the input supply of >2.9V is applied. To disable the device, apply a voltage below 0.5V to the EN (J3) terminal.
4. **Power Good.** The board provides a Power Good test point (J4) to monitor the Power Good function. The Power Good output goes high (V_{OUT}) approximately 160 μ s after the output voltage reaches 90% of its nominal voltage.

Ordering Information

Part Number	Description
MIC23303YML EV	Adjustable Output Evaluation Board

Hyper Light Load is a registered trademark of Micrel, Inc.

MLF and MicroLeadFrame are registered trademark Amkor Technology Inc.

Micrel Inc. • 2180 Fortune Drive • San Jose, CA 95131 • USA • tel +1 (408) 944-0800 • fax + 1 (408) 474-1000 • <http://www.micrel.com>

Evaluation Board

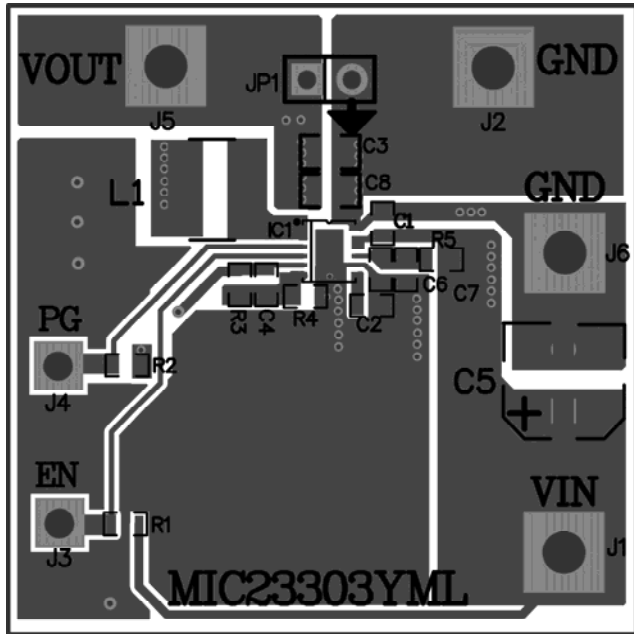

The feed-forward capacitor, C4, can be fitted to improve transient performance. This improves transients by injecting fast output voltage deviations directly into the feedback comparator. This improved load regulation is at the expense of slightly increasing the amount of noise on the output at higher loads. A typical value range of 22pF to 68pF is recommended.

Power Good (PG)

The evaluation board provides a test point above EN for testing PG. This is an open-drain connection to the output voltage with an on-board pull-up resistor of 10kΩ. This is asserted high approximately 160μs after the output voltage passes 90% of the nominal set voltage.

Hyper Light Load® Mode

MIC23303 uses a minimum on and off time proprietary control loop (patented by Micrel). When the output voltage falls below the regulation threshold, the error comparator begins a switching cycle that turns the PMOS on and keeps it on for the duration of the minimum-on-time. This increases the output voltage. If the output voltage is over the regulation threshold, the error comparator turns the PMOS off for a minimum-off-time until the output drops below the threshold. The NMOS acts as an ideal rectifier that conducts when the PMOS is off. Using an NMOS switch instead of a diode allows for lower voltage drop across the switching device when it is on. The asynchronous switching combination between the PMOS and the NMOS allows the control loop to work in discontinuous mode for light load operations. In discontinuous mode, the MIC23303 works in pulse frequency modulation (PFM) to regulate the output. As the output current increases, the off-time decreases, which provides more energy to the output. This switching scheme improves the efficiency of MIC23303 during light load currents by switching only when it is needed. As the load current increases, the MIC23303 goes into continuous conduction mode (CCM) and switches at a frequency centered at 4MHz. The equation to calculate the load when the MIC23303 goes into continuous conduction mode is approximated by the following formula:

$$I_{LOAD} > \left(\frac{(V_{IN} - V_{OUT}) \times D}{2L \times f} \right)$$

The previous equation shows that the load at which MIC23303 transitions from Hyper Light Load mode to PWM mode is a function of the input voltage (V_{IN}), output voltage (V_{OUT}), duty cycle (D), inductance (L), and frequency (f). The “Switching Frequency vs. Load” graph on page 3 shows that, as the output current increases, the switching frequency also increases until the MIC23303 goes from Hyper Light Load mode to PWM mode at approximately 300mA. The MIC23303 will switch at a relatively constant frequency around 4MHz after the output current is over 300mA.

Other Features

Soft-Start Capacitor (C2)

The soft-start (SS) pin is used to control the output voltage ramp-up time. Setting C2 to 2.2nF sets the start-up time to the minimum. The start-up time can be determined by:

$$T_{SS} = 250 \times 10^3 \times \ln(10) \times C_{SS}$$

The soft-start capacitor controls the rise time of the internal reference voltage between 0% and 100% of its nominal steady state value.

Feedback Resistors (R3, R4) for Adjustable Output

The output voltage is set nominally to 1.8V. This output can be changed by adjusting the upper resistor, R3, in the feedback potential divider. Therefore:

$$R3 = R4 \times V_{REF} / (V_O - V_{REF})$$

Where V_{REF} = 0.62V.

Some example values are:

V _{OUT}	R3	R4
1.2V	274kΩ	294kΩ
1.5V	316kΩ	221kΩ
1.8V	560kΩ	294kΩ
2.5V	324kΩ	107kΩ
3.3V	464kΩ	107kΩ

Evaluation Board Performance

Switching Frequency vs. Load Current

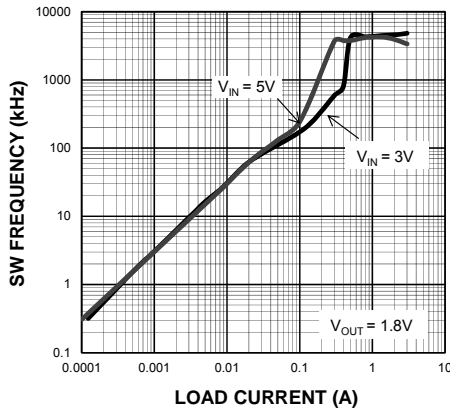

Efficiency vs. Load 1.8V_{OUT} @25°C

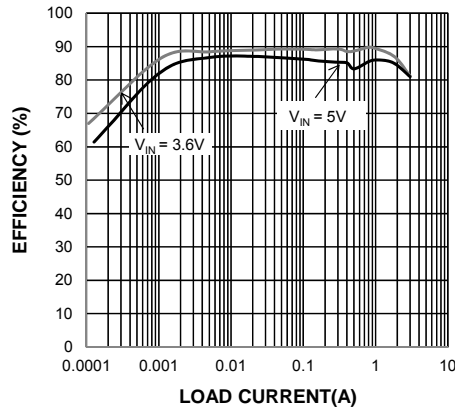

Efficiency vs. Load 1.2V_{OUT} @25°C

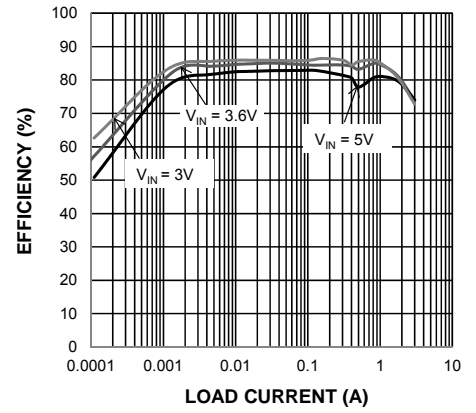

V_{OUT} Rise Time vs. C_{SS}

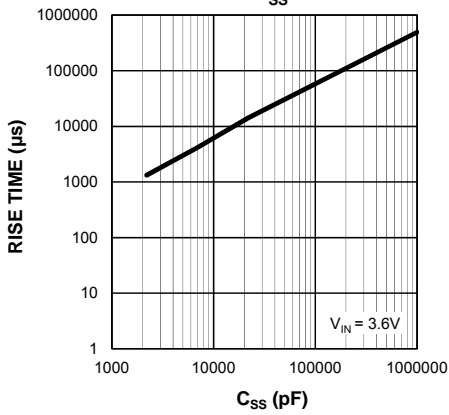

Enable Threshold vs. Input Voltage

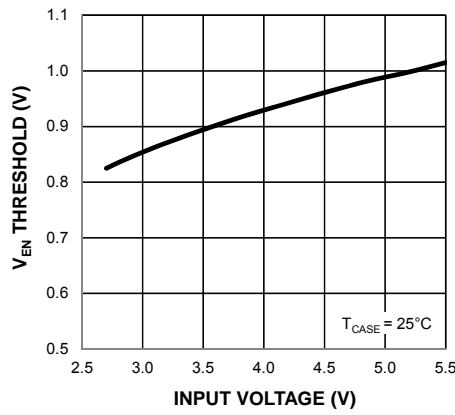

MIC23303-YML Evaluation Board Schematic

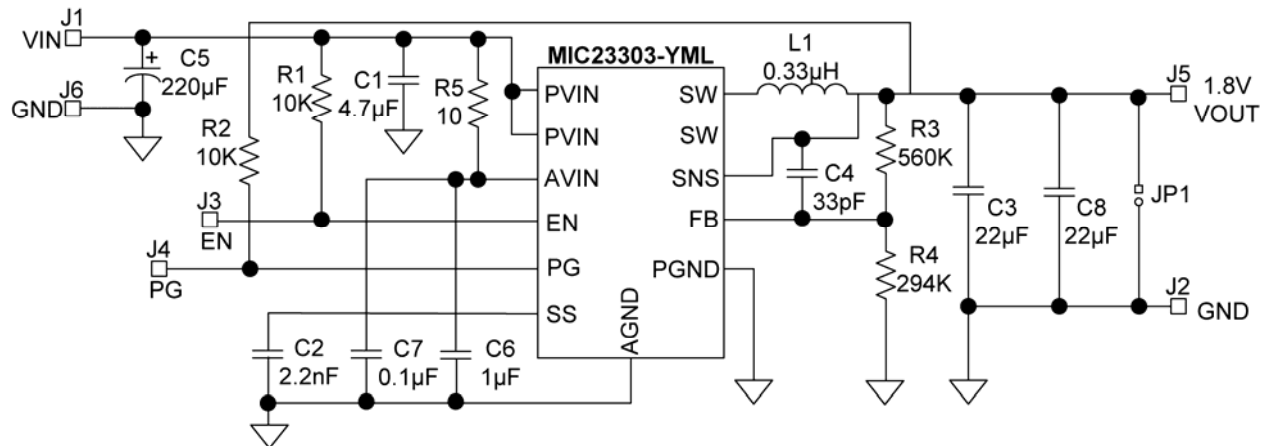

Bill of Materials

Item	Part Number	Manufacturer	Description	Qty
C1	06036D475KAT2A	AVX ⁽¹⁾	4.7 μ F/6.3V, X5R, 0603	1
	GRM188R60J475ME19D	Murata ⁽²⁾		
	C1608X5R0J475M	TDK ⁽³⁾		
C2	06035C222KAT2A	AVX	2.2nF/50V, X7R, 0603	1
	GRM188R71H222MA01D	Murata		
	C1608X7R1H222K	TDK		
C3,C8	08056D226MAT2A	AVX	22 μ F/6.3V, X5R, 0805	1
	GRM21BR60J226ME39L	Murata		
	C2012X5R0J226M	TDK		
C4	06035A330KAT2A	AVX	33pF/50V, 0603	1
	GRM1885C1H330JA01D	Murata		
C5	ECA-1AHG221	Panasonic ⁽⁴⁾	CAP ALUM 220UF 10V 20% RADIAL	1
C6	06036D105KAT2A	AVX	1 μ F/6.3V, X5R, 0603	1
	GRM188R60J105KA01D	Murata		
	C1608X5R0J105K	TDK		
C7	06035D104KAT2A	AVX	0.1 μ F/6.3V, X5R, 0603	1
	GRM188R71H104KA930	Murata		
	C1608X5R1H104K	TDK		
L1	0520CDMCD SNP-R33MC	Sumida ⁽⁵⁾	0.33 μ H/5.6A, 8m Ω	1
	744373240033	Würth ⁽⁶⁾	0.33 μ H/8.0A, 8.6m Ω	
R1,R2	CRCW060310K0FKEA	Vishay/Dale ⁽⁷⁾	10K, 1%, 1/10W, 0603	2
R3	CRCW0603560K FKEA	Vishay/Dale	560K, 1%, 1/10W, 0603	1
R4	CRCW0603294K FKEA	Vishay/Dale	294K, 1%, 1/10W, 0603	1
R5	CRCW060310R0FKEA	Vishay/Dale	10 Ω , 1%, 1/10W, 0603	1
IC1	MIC23303-YML	Micrel, Inc. ⁽⁸⁾	4MHz 3A Buck Regulator with Hyper Light Load [®] Mode	1

Notes:

1. AVX: www.avx.com.
2. TDK: www.tdk.com.
3. Murata: www.murata.com.
4. Panasonic: www.panasonic.com.
5. Sumida: www.sumida.com.
6. Würth: www.we-online.com.
7. Vishay: www.vishay.com.
8. Micrel, Inc.: www.micrel.com.

PCB Layout Recommendations

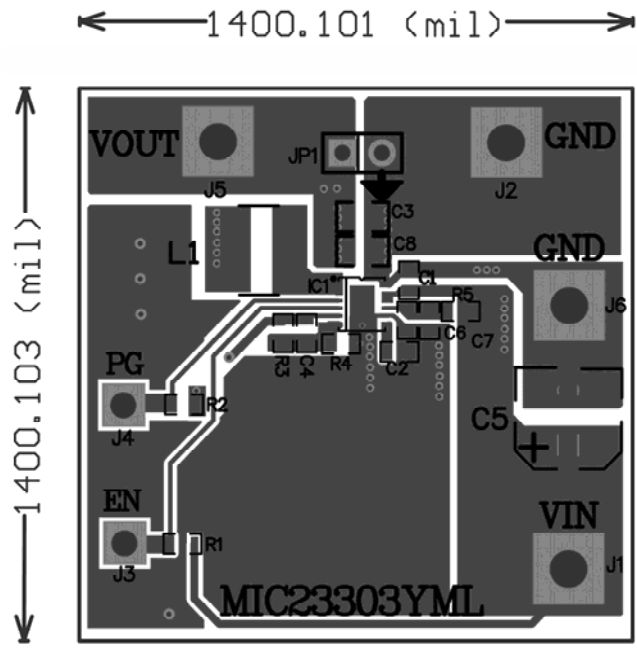

Top Layer

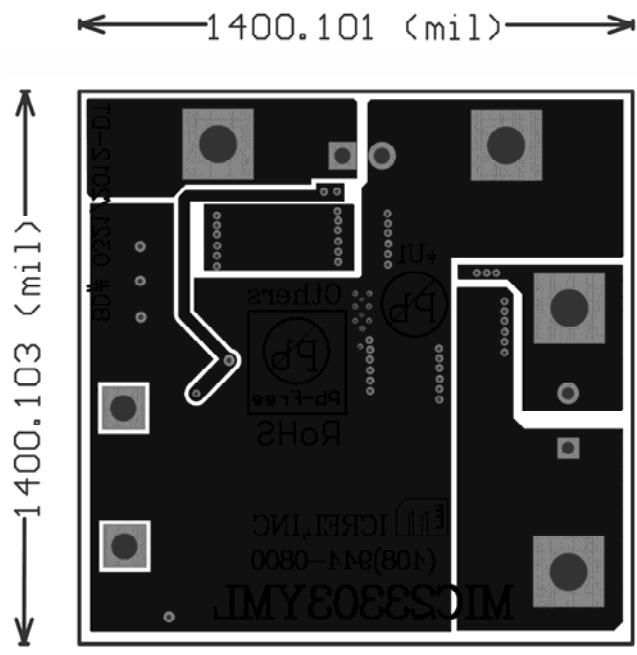

Bottom Layer

MICREL, INC. 2180 FORTUNE DRIVE SAN JOSE, CA 95131 USA
TEL +1 (408) 944-0800 FAX +1 (408) 474-1000 WEB <http://www.micrel.com>

Micrel makes no representations or warranties with respect to the accuracy or completeness of the information furnished in this data sheet. This information is not intended as a warranty and Micrel does not assume responsibility for its use. Micrel reserves the right to change circuitry, specifications and descriptions at any time without notice. No license, whether express, implied, arising by estoppel or otherwise, to any intellectual property rights is granted by this document. Except as provided in Micrel's terms and conditions of sale for such products, Micrel assumes no liability whatsoever, and Micrel disclaims any express or implied warranty relating to the sale and/or use of Micrel products including liability or warranties relating to fitness for a particular purpose, merchantability, or infringement of any patent, copyright or other intellectual property right.

Micrel Products are not designed or authorized for use as components in life support appliances, devices or systems where malfunction of a product can reasonably be expected to result in personal injury. Life support devices or systems are devices or systems that (a) are intended for surgical implant into the body or (b) support or sustain life, and whose failure to perform can be reasonably expected to result in a significant injury to the user. A Purchaser's use or sale of Micrel Products for use in life support appliances, devices or systems is a Purchaser's own risk and Purchaser agrees to fully indemnify Micrel for any damages resulting from such use or sale.

© 2012 Micrel, Incorporated.