



MIC23450 Evaluation Board

3MHz, PWM, 2A Triple Buck Regulator
with HyperLight Load® and Power Good

General Description

This board allows the customer to evaluate the MIC23450, a fully-integrated, triple-output, 2A, 3MHz switching regulator that features HyperLight Load® mode and power good (PG) output indicators. The MIC23450 is highly efficient throughout the output current range, drawing just 23µA of quiescent current for each channel in operation. The tiny 5mm x 5mm MLF® package saves board space and requires few external components. The MIC23450 provides ±2.5% output voltage accuracy and each channel responds typically in less than 10µs to a load transient with as low as 5mV output voltage ripple.

Requirements

This board needs a single 40W bench power source, adjustable from 2.7V to 5.5V. The loads can be either active (electronic load) or passive (resistor), and must be able to dissipate 20W. It is ideal, but not essential, to have an oscilloscope available to view the circuit waveforms. The simplest tests require two voltage meters to measure input and output voltage. Efficiency measurements for a single channel require two voltage meters and two ammeters to prevent errors caused by measurement inaccuracies.

Precautions

There is no reverse input protection on this board. Be careful when connecting the input source to make sure correct polarity is observed.

Getting Started

1. **Connect an external supply to the V_{IN} (J1) terminal and GND (J3).**

With the output of the power supply disabled, set its voltage to the desired input test voltage ($2.7V \leq V_{IN} \leq 5.5V$). An ammeter may be placed between the input supply and the V_{IN} (J1) terminal. Be sure to monitor the supply voltage at the V_{IN} (J1) terminal, as the ammeter and/or power lead resistance can reduce the voltage supplied to the device.

2. **Connect a load to the V_{OUT} terminals (J2, J5, J7) and ground (J4, J6, J8) terminals.**

The load can be either active passive (resistive) or active (electronic load). An ammeter may be placed between the loads and the output terminals. Make sure the output voltage is monitored at V_{OUT1}, V_{OUT2} and V_{OUT3} (J2, J5 and J7) terminals. The board has multiple 2-pin connectors (JP1, JP2 and JP3) to allow for output voltage monitoring of V_{OUT1}, V_{OUT2} and V_{OUT3} respectively.

3. **Enable the Supply to MIC23450.**

The MIC23450 evaluation board has a pull-up resistor to V_{IN} for each channel. By default, each output voltage is enabled when the input supply of >2.7V is applied. Each channel 1, 2 or 3 can be disabled by applying a voltage below 0.4V to the EN terminal J10, J12 or J14 respectively.

4. **Power Good.**

The board provides a power good test point (J9, J11, and J13) to monitor the power good function for each of the channels 1, 2, and 3 respectively. The power good output goes high (V_{OUT}) nominally 62µs after the output voltage reaches 90% of its nominal voltage.

Ordering Information

| Part Number | Description |
|--------------------|--|
| MIC23450-AAAYML EV | 3MHz, PWM, 2A Triple Buck Regulator Evaluation Board |

HyperLight Load is a registered trademark of Micrel, Inc.

MLF and MicroLeadFrame are registered trademark Amkor Technology Inc.

Micrel Inc. • 2180 Fortune Drive • San Jose, CA 95131 • USA • tel +1 (408) 944-0800 • fax + 1 (408) 474-1000 • <http://www.micrel.com>

February 4, 2013

Revision 1.0

Evaluation Board

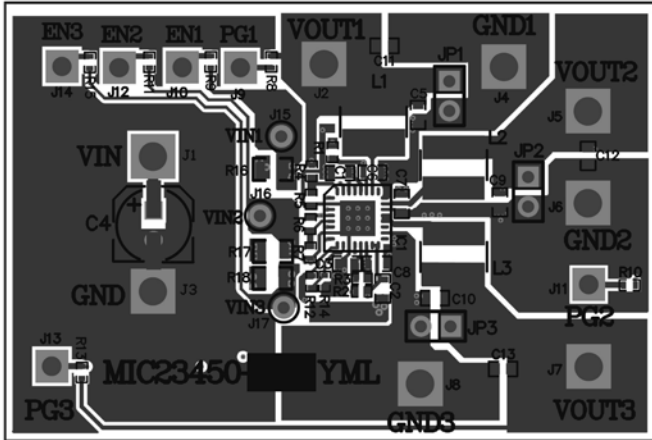

Other Features

Soft-Start

The MIC23450 has an internal soft start for each individual channel and requires no external soft start capacitor. The typical soft-start time for each channel is 115µs.

Feedback Resistors (R4-R7, R12, R14)

The feedback pins FB1, FB2, and FB3 are the control inputs for programming the output voltages V_{OUT1} , V_{OUT2} and V_{OUT3} respectively. Resistor divider networks are connected to these pins from the output and are compared to the internal 0.62V reference within the regulation loop. The output voltage can be programmed between 1V and 3.3V using resistor values calculated by Equation 1:

$$\begin{aligned} V_{OUT1} &= V_{REF} \cdot \left(1 + \frac{R4}{R5}\right) \\ V_{OUT2} &= V_{REF} \cdot \left(1 + \frac{R6}{R7}\right) \\ V_{OUT3} &= V_{REF} \cdot \left(1 + \frac{R12}{R14}\right) \end{aligned} \quad \text{Eq. 1}$$

Example feedback resistor values are provided in [Table 1](#).

Table 1
Output Voltage Programming Examples

| V_{OUT1} , V_{OUT2} , V_{OUT3} | R4, R6, R12 | R5, R7, R14 |
|--------------------------------------|-------------|-------------|
| 1.2V | 274k | 294k |
| 1.5V | 316k | 221k |
| 1.8V | 301k | 158k |
| 2.5V | 324k | 107k |
| 3.3V | 309k | 71.5k |

Power Good (PG1, PG2, PG3)

The evaluation board has test points for channels 1, 2, and 3 to monitor the PG1, PG2 and PG3 signals. These are open-drain connections to the corresponding output voltage with on-board pull-up resistors of 100kΩ. The PG signal will be asserted high approximately 62µs after the output voltage passes 90% of the nominal set voltage.

Hyper Light Load Mode

The MIC23450 uses a minimum on and off time proprietary control loop (patented by Micrel). When the output voltage falls below the regulation threshold, the error comparator begins a switching cycle that turns the PMOS on and keeps it on for the duration of the minimum-on-time. This increases the output voltage. If the output voltage is over the regulation threshold, the error comparator turns the PMOS off for a minimum-off-time until the output drops below the threshold. The NMOS acts as an ideal rectifier that conducts when the PMOS is off. Using an NMOS switch instead of a diode allows for lower voltage drop across the switching device when it is on. The asynchronous switching combination between the PMOS and the NMOS allows the control loop to work in discontinuous mode for light load operations. In discontinuous mode, the MIC23450 works in pulse frequency modulation (PFM) to regulate the output. As the output current increases, the off-time decreases, which provides more energy to the output. This switching scheme improves the efficiency of MIC23450 during light load currents by switching only when it is needed. As the load current increases, the MIC23450 goes into continuous conduction mode (CCM) and switches at a frequency centered at 3MHz. The equation to calculate the load when the MIC23450 goes into continuous conduction mode is approximated by Equation 2:

$$I_{LOAD} > \left(\frac{(V_{IN} - V_{OUT}) \times D}{2L \times f} \right) \quad \text{Eq. 2}$$

Equation 1 shows that the load at which MIC23450 transitions from HyperLight Load mode to PWM mode is a function of the input voltage (V_{IN}), output voltage (V_{OUT}), duty cycle (D), inductance (L), and frequency (f). The “Switching Frequency vs. Load” graph on page 3 shows that, as the output current increases, the switching frequency also increases until the MIC23450 goes from HyperLight Load mode to PWM mode at approximately 150mA. The MIC23450 will switch at a relatively constant frequency around 3MHz after the output current is over 150mA.

Multiple Sources

The MIC23450 provides all the pins necessary to operate the three regulators from independent sources. This can be useful in partitioning power within a multi rail system. For example, it is possible that within a system, two supplies are available; 3.3V and 5V. The MIC23450 can be connected to use the 3.3V supply to provide two, low voltage outputs (e.g. 1.2V and 1.8V) and use the 5V rail to provide a higher output (e.g. 2.5V), resulting in the power blocks shown in Figure 1.

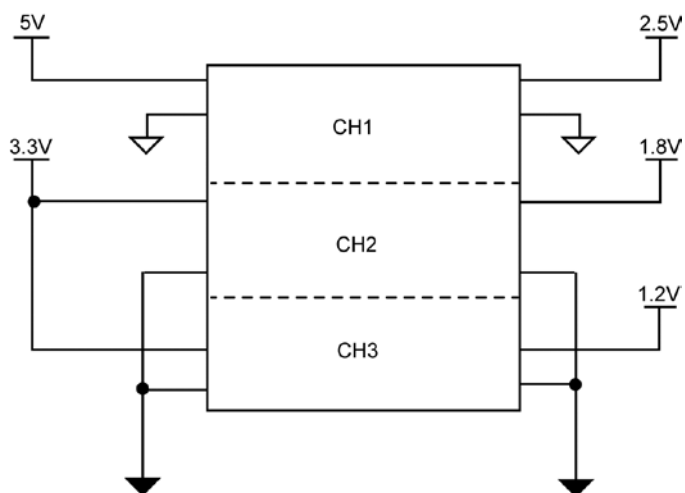
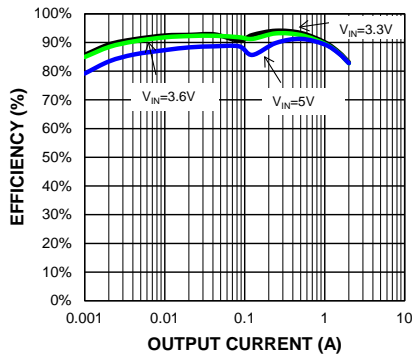

Figure 1. Multi-Source Power Block Diagram

To achieve this multiple source configuration on the MIC23450YML EV, the PVIN and AVIN of each channel must first be isolated from the global VIN by removing the VIN resistor; R16 for Channel 1, R17 for Channel 2 and R18 for Channel 3. Once the global VIN is isolated, a separate VIN source may then be supplied to the isolated channel through the terminals provided (J15, J16 and J17) which are labeled VIN1, VIN2 or VIN3 according to which channel they supply.

Evaluation Board Performance

Efficiency vs. Output Current
 $V_{OUT} = 2.5V$



Efficiency vs. Output Current
 $V_{OUT} = 1.8V$

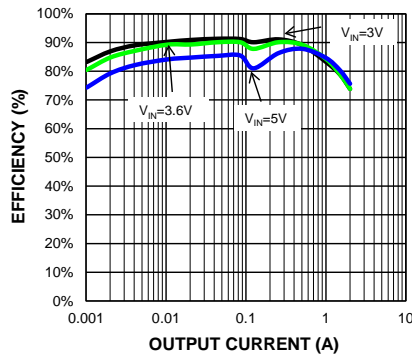

Line Regulation (Low Loads)

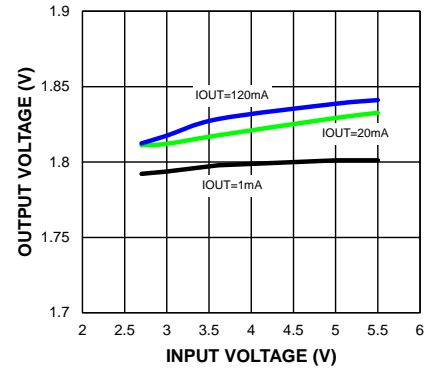

Line Regulation (High Loads)

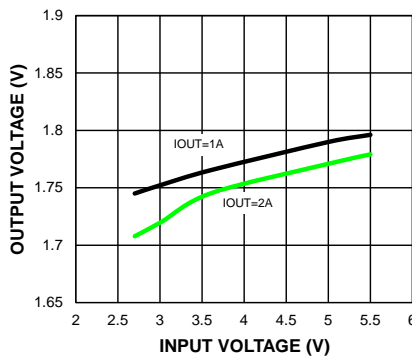

Maximum Output Current per O/P vs. Temperature (1 O/P)

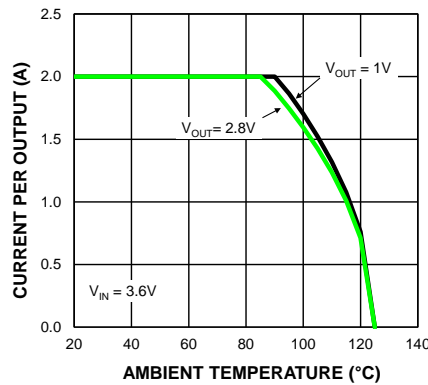

Maximum Output Current per O/P vs. Temperature (2 O/Ps)

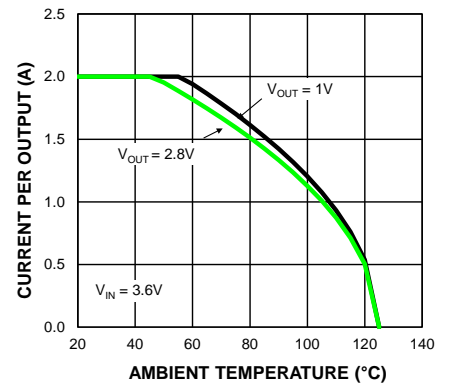

Maximum Output Current per O/P vs. Temperature (3 O/Ps)

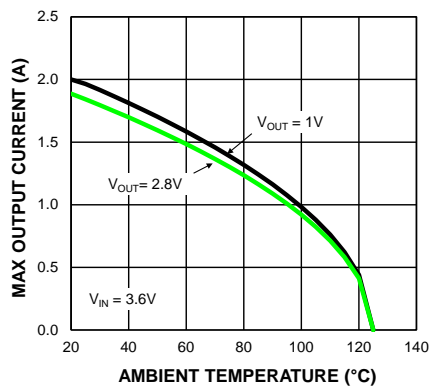

Power Dissipation vs. Load Current (per Channel)

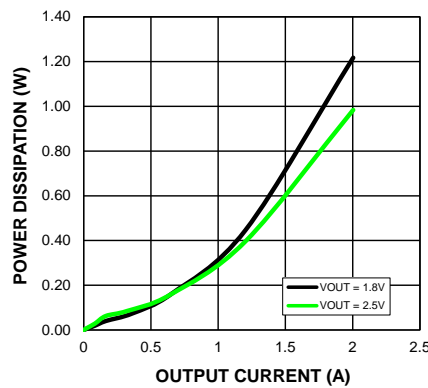

Maximum Package Dissipation vs. Ambient Temperature

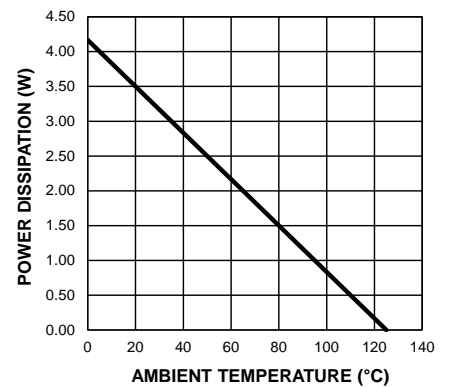

MIC23450YML Evaluation Board Schematic

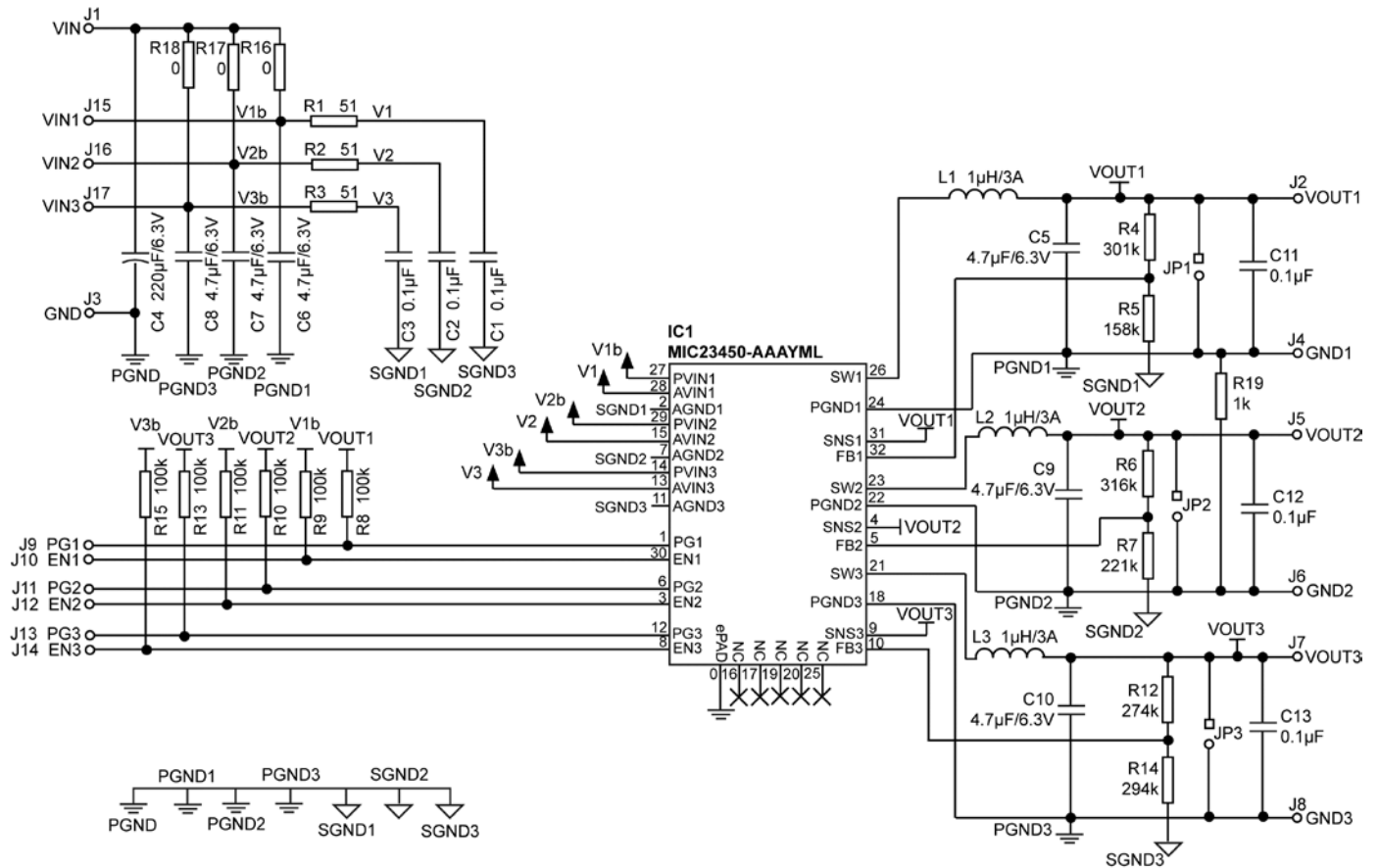

Bill of Materials

| Item | Part Number | Manufacturer | Description | Qty. |
|----------------------------------|--------------------|-----------------------------|--|------|
| C1, C2, C3, C11, C12, C13 | C1608X5R1E104K | TDK ⁽¹⁾ | Ceramic Capacitor, 0.1 μ F, 6.3V, X5R, Size 0603 | 6 |
| | GRM188R60J104KD | Murata ⁽²⁾ | | |
| C4 | EEUFR1A221 | Panasonic ⁽³⁾ | Electrolytic Capacitor, 220 μ F, 10V, Size 6.3mm | 1 |
| C5–C10 | C1608X5R0J475K | TDK | Ceramic Capacitor, 4.7 μ F, 6.3V, X5R, Size 0603 | 6 |
| | GRM188R60J475KE19D | Murata | | |
| R1, R2, R3 | CRCW040251R0FKEA | Vishay ⁽⁴⁾ | Resistor, 51 Ω , Size 0402 | 3 |
| R4 | CRCW04023013FKEA | Vishay | Resistor, 301k Ω , Size 0402 | 1 |
| R5 | CRCW04021583FKEA | Vishay | Resistor, 158k Ω , Size 0402 | 1 |
| R6 | CRCW04023163FKEA | Vishay | Resistor, 316k Ω , Size 0402 | 1 |
| R7 | CRCW04022213FKEA | Vishay | Resistor, 221k Ω , Size 0402 | 1 |
| R12 | CRCW04022743FKEA | Vishay | Resistor, 274k Ω , Size 0402 | 1 |
| R14 | CRCW04022943FKEA | Vishay | Resistor, 294k Ω , Size 0402 | 1 |
| R8, R9, R10, R11, R13, R15 | CRCW04021003FKEA | Vishay | Resistor, 100k Ω , Size 0402 | 6 |
| R16, R17, R18 | CRCW08050000FKEA | Vishay | Resistor, 0 Ω , Size 0805 | 3 |
| L1, L2, L3 | VLS3012ST-1R0N1R9 | TDK | 1 μ H, 2A, 60m Ω , L3.0mm x W3.0mm x H1.0mm | 3 |
| | LQH44PN1R0NJ0 | Murata | 1 μ H, 2.8A, 50m Ω , L4.0mm x W4.0mm x H1.2mm | |
| U1 | MIC23450-AAAYML | Micrel, Inc. ⁽⁵⁾ | 3MHz PWM 2A Buck Regulator with HyperLight Load | 1 |

Notes:

1. TDK: www.tdk.com.
2. Murata: www.murata.com.
3. Panasonic: www.panasonic.com.
4. Vishay: www.vishay.com.
5. Micrel, Inc.: www.micrel.com.

PCB Layout Recommendations

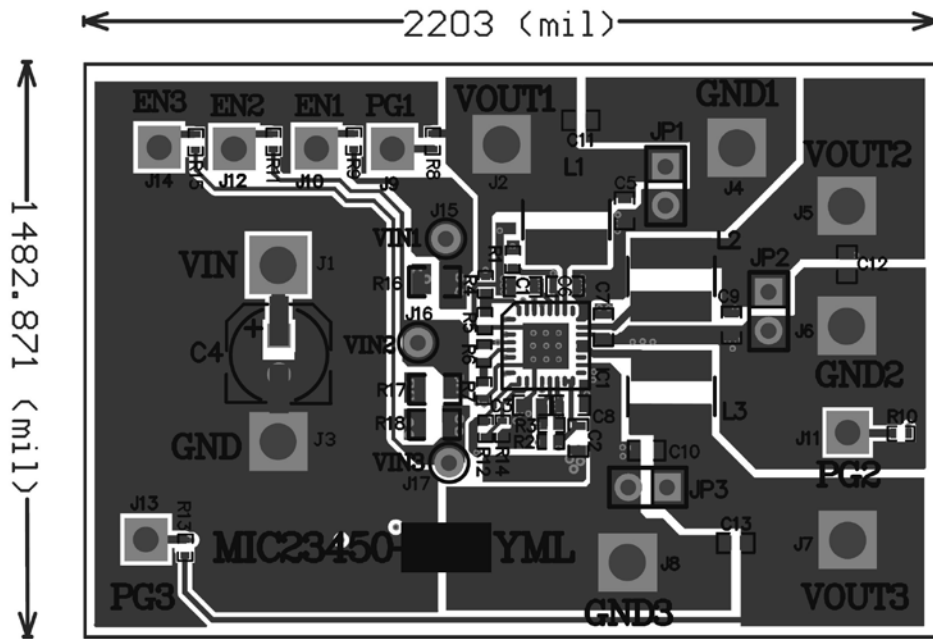

Top Layer

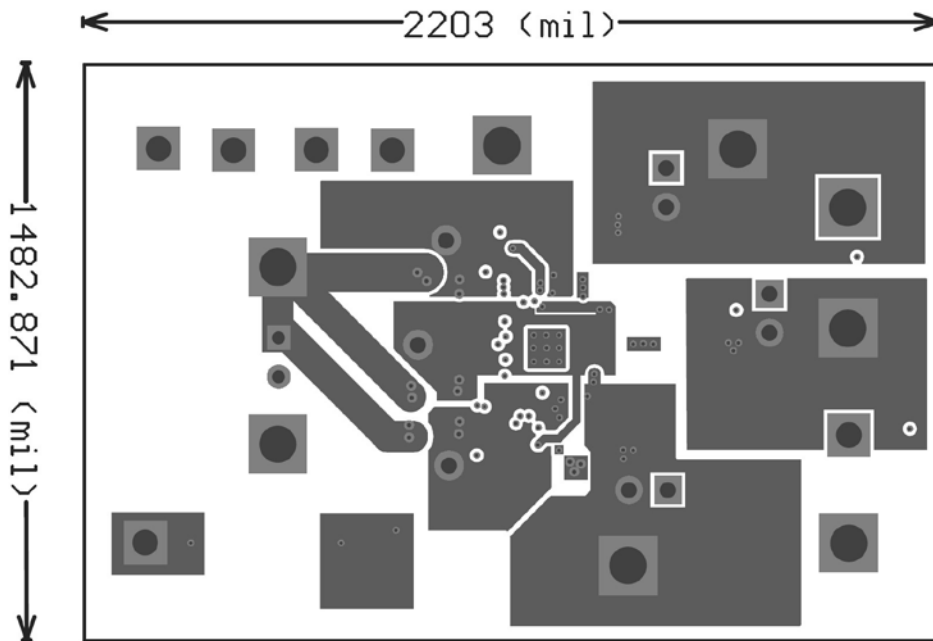

Layer 2

PCB Layout Recommendations (Continued)

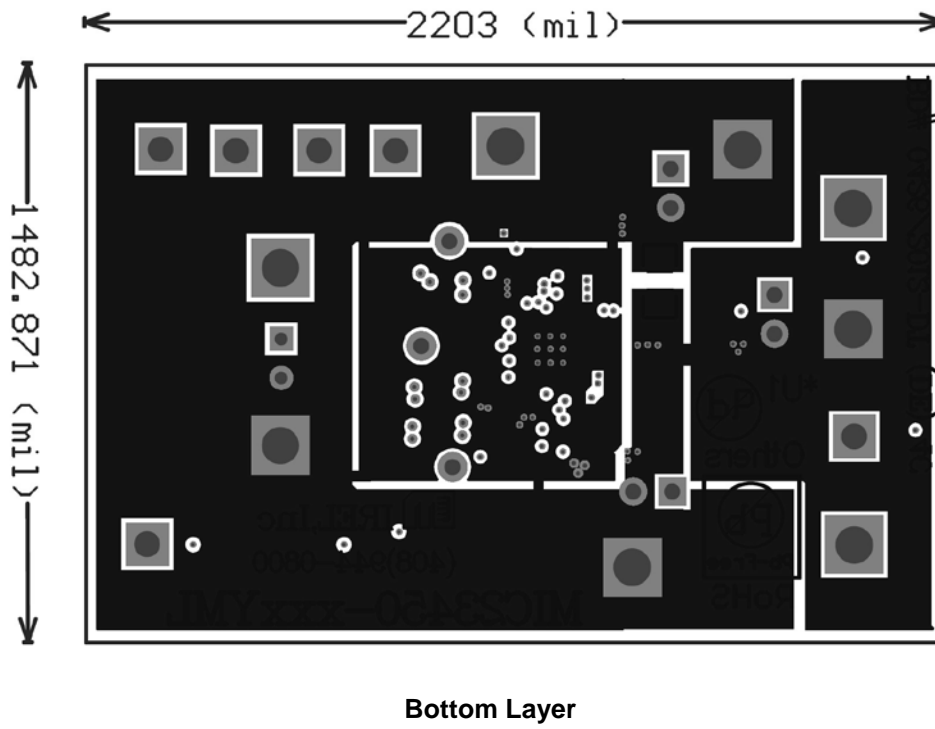
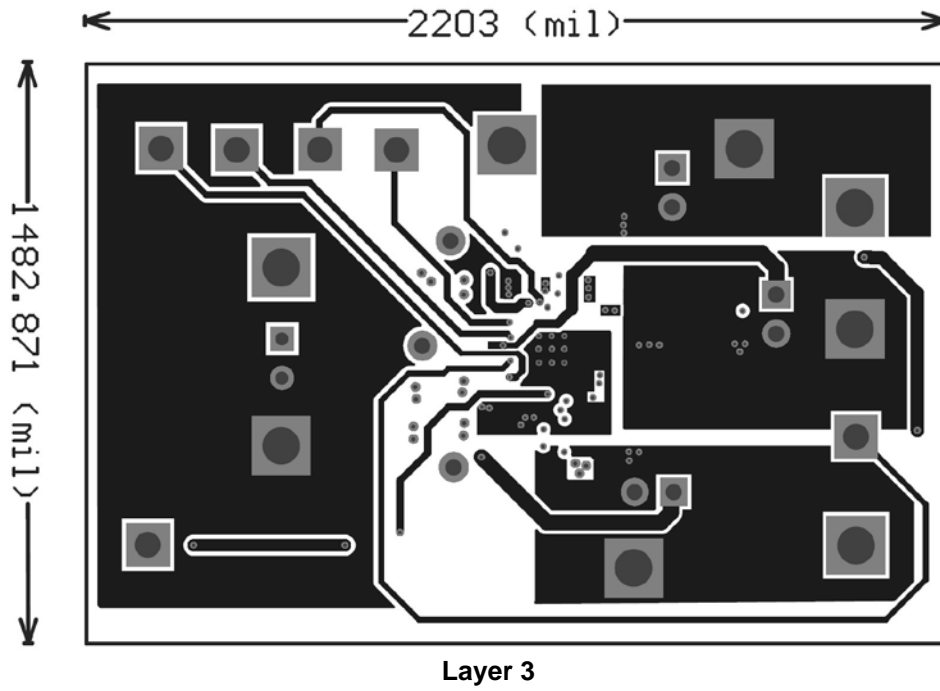

MICREL, INC. 2180 FORTUNE DRIVE SAN JOSE, CA 95131 USATEL +1 (408) 944-0800 FAX +1 (408) 474-1000 WEB <http://www.micrel.com>

Micrel makes no representations or warranties with respect to the accuracy or completeness of the information furnished in this data sheet. This information is not intended as a warranty and Micrel does not assume responsibility for its use. Micrel reserves the right to change circuitry, specifications and descriptions at any time without notice. No license, whether express, implied, arising by estoppel or otherwise, to any intellectual property rights is granted by this document. Except as provided in Micrel's terms and conditions of sale for such products, Micrel assumes no liability whatsoever, and Micrel disclaims any express or implied warranty relating to the sale and/or use of Micrel products including liability or warranties relating to fitness for a particular purpose, merchantability, or infringement of any patent, copyright or other intellectual property right.

Micrel Products are not designed or authorized for use as components in life support appliances, devices or systems where malfunction of a product can reasonably be expected to result in personal injury. Life support devices or systems are devices or systems that (a) are intended for surgical implant into the body or (b) support or sustain life, and whose failure to perform can be reasonably expected to result in a significant injury to the user. A Purchaser's use or sale of Micrel Products for use in life support appliances, devices or systems is a Purchaser's own risk and Purchaser agrees to fully indemnify Micrel for any damages resulting from such use or sale.

© 2013 Micrel, Incorporated.