



MICROCHIP PIC18F2410/2510/4410/4510

PIC18F2410/2510/4410/4510 Rev. A1 Silicon Errata

The PIC18F2410/2510/4410/4510 Rev. A1 parts you have received conform functionally to the Device Data Sheet (DS39636C), except for the anomalies described below. Any Data Sheet Clarification issues related to the PIC18F2410/2510/4410/4510 will be reported in a separate Data Sheet errata. Please check the Microchip web site for any existing issues.

The following silicon errata apply only to PIC18F2410/2510/4410/4510 devices with these Device/Revision IDs:

Part Number	Device ID	Revision ID
PIC18F2410	0001 0001 011	0 0100
PIC18F2510	0001 0001 001	0 0100
PIC18F4410	0001 0000 111	0 0100
PIC18F4510	0001 0000 101	0 0100

The Device IDs (DEVID1 and DEVID2) are located at addresses 3FFFFEh:3FFFFFh in the device's configuration space. They are shown in binary in the format "DEVID2 DEVID1".

1. Module: MSSP

In its current implementation, the I²C™ Master mode operates as follows:

- a) The Baud Rate Generator for I²C in Master mode is slower than the rates specified in Table 16-3 of the Device Data Sheet.

For this revision of silicon, use the values shown in Table 1 in place of those shown in Table 16-3 of the Device Data Sheet. The differences are shown in **bold** text.

- b) Use the following formula in place of the one shown in Register 16-2 (SSPCON1) of the Device Data Sheet for bit description SSPM3:SSPM0 = 1000.

$$SSPADD = \text{INT}((F_{CY}/F_{SCL}) - (F_{CY}/1.111 \text{ MHz})) - 1$$

Date Codes that pertain to this issue:

All engineering and production devices.

TABLE 1: I²C™ CLOCK RATE w/BRG

Fosc	Fcy	Fcy * 2	BRG Value	Fscl (2 Rollovers of BRG)
40 MHz	10 MHz	20 MHz	0Eh	400 kHz ⁽¹⁾
40 MHz	10 MHz	20 MHz	15h	312.5 kHz
40 MHz	10 MHz	20 MHz	59h	100 kHz
16 MHz	4 MHz	8 MHz	05h	400 kHz ⁽¹⁾
16 MHz	4 MHz	8 MHz	08h	308 kHz
16 MHz	4 MHz	8 MHz	23h	100 kHz
4 MHz	1 MHz	2 MHz	01h	333 kHz ⁽¹⁾
4 MHz	1 MHz	2 MHz	08h	100 kHz
4 MHz	1 MHz	2 MHz	00h	1 MHz ⁽¹⁾

Note 1: The I²C™ interface does not conform to the 400 kHz I²C specification (which applies to rates greater than 100 kHz) in all details, but may be used with care where higher rates are required by the application.

PIC18F2410/2510/4410/4510

2. Module: MSSP

After an I²C transfer is initiated, the SSPBUF register may be written for up to 10 T_{CY} before additional writes are blocked. The data transfer may be corrupted if SSPBUF is written during this time.

The WCOL bit is set any time an SSPBUF write occurs during a transfer.

Work around

Avoid writing SSPBUF until the data transfer is complete, indicated by the setting of the SSPIF bit (PIR1<3>).

Verify the WCOL bit (SSPCON1<7>) is clear after writing SSPBUF to ensure any potential transfer in progress is not corrupted.

Date Codes that pertain to this issue:

All engineering and production devices.

3. Module: MSSP

In 10-Bit Addressing mode, when a Repeated Start is issued followed by the high address byte and a write command (R/W = 0), an ACK is not issued.

Work around

There are two work arounds available:

1. Single Master Environment:

In a single master environment, the user must issue a Stop, then a Start followed by a write to the address high, then the address low followed by the data.

2. Multi-Master Environment:

In a multi-master environment, the user must issue a Repeated Start, send a dummy write command to a different address, issue another Repeated Start and then send a write to the original address. This procedure will help maintain control of the bus.

Date Codes that pertain to this issue:

All engineering and production devices.

4. Module: MSSP

I²C Receive mode should be enabled (i.e., RCEN bit should be set) only when the system is idle (i.e., when ACKEN, RCEN, PEN, RSEN and SEN all equal zero). It should not be possible to set the RCEN bit when the system is not idle, however, the RCEN bit can be set under this circumstance.

Work around

Wait for the system to become idle before setting the RCEN bit. This requires a check for the following bits to be clear:

ACKEN, RCEN, PEN, RSEN and SEN.

Date Codes that pertain to this issue:

All engineering and production devices.

5. Module: ECCP

When the CCP1 auto-shutdown feature is configured for automatic restart by setting the PRSEN bit (PWM1CON<7>), the pulse terminates immediately in a shutdown event. In addition, the pulse may restart within the period if the shutdown condition expires. This may result in the generation of short pulses on the PWM output(s).

Work around

Configure the auto-shutdown for software restart by clearing the PRSEN bit (PWM1CON<7>). The PWM can be re-enabled by clearing the ECCPASE bit (ECCP1AS<7>) after the shutdown condition expires.

Date Codes that pertain to this issue:

All engineering and production devices.

6. Module: ECCP

When monitoring a shutdown condition using a bit test on the ECCPASE bit (ECCP1AS<7>), or performing a bit operation on the ECCPASE bit, the device may produce unexpected results.

Work around

Before performing a bit test or bit operation on the ECCPASE bit, copy the ECCP1AS register to the working register and perform the operation there.

By avoiding these operations on the ECCPASE bit in the ECCP1AS register, the module will operate normally.

In Example 1, ECCPASE bit operations are performed on the W register.

Date Codes that pertain to this issue:

All engineering and production devices.

EXAMPLE 1:

```
MOVWF    ECCP1AS, W
BTFSC   WREG, ECCPASE
BRA     SHUTDOWN_ROUTINE
```

7. Module: ECCP

The auto-shutdown source, FLT0, has inverse polarity from the description in **Section 15.4.7 “Enhanced PWM Auto-Shutdown”** of the Device Data Sheet. A logic high-voltage level on FLT0 will generate a shutdown on CCP1.

Work around

None.

Date Codes that pertain to this issue:

All engineering and production devices.

8. Module: ECCP and CCP

The CCP1 and CCP2 configured for PWM mode, with 1:1 Timer2 prescaler and duty cycle set to the period minus 1, may result in the PWM output(s) remaining at a logic low level.

Clearing the PR2 register to select the fastest period may also result in the output(s) remaining at a logic low output level.

Work around

To ensure a reliable waveform, verify that the selected duty cycle does not equal the 10-bit period minus 1 prior to writing these locations, or use 1:4 or 1:16 Timer2 prescale. Also, verify the PR2 register is not written to 00h.

All other duty cycle and period settings will function as described in the Device Data Sheet.

The ECCP and CCP modules remain capable of 10-bit accuracy.

Date Codes that pertain to this issue:

All engineering and production devices.

9. Module: ECCP

CCP1 configured for auto-shutdown with Comparator 1 corrupts the PWM duty cycle pulse. In addition, it does not always synchronize the pulse to the beginning of the period and the end of the pulse can occur at any time within the period.

Work around

Use FLT0 for the auto-shutdown source. Applications which can tolerate a shutdown response time of several Tcys may use the comparator interrupt flag to detect a shutdown event and disable the PWM by clearing the ECCPASE bit (ECCP1AS<7>).

Date Codes that pertain to this issue:

All engineering and production devices.

PIC18F2410/2510/4410/4510

10. Module: ECCP

When the shutdown state of the PWM pin(s) is configured to tri-state the outputs, the device may consume higher than expected current during the shutdown event.

Work around

Configure the PWM output for either a high or low logic state during the shutdown via the PSSAC1:PSSAC0 (ECCP1AS<3:2>) and PSSBD1:PSSBD0 (ECCP1AS<1:0>) bits. Clearing the auto-shutdown event will return the device to normal current consumption levels.

Date Codes that pertain to this issue:

All engineering and production devices.

11. Module: ECCP

The PWM pin(s) may change state if a breakpoint is encountered during emulation and an auto-shutdown event occurs via FLT0. This affects the MPLAB® ICD 2 debugger and the MPLAB® ICE 2000 and MPLAB® ICE 4000 emulators.

Work around

During emulation, use the comparator for auto-shutdown or use the external interrupt (INT0) flag to detect a shutdown event and disable the PWM by clearing the ECCPASE bit (ECCP1AS<7>).

Date Codes that pertain to this issue:

All engineering and production devices.

12. Module: ECCP

When operating either Timer1 or Timer3 as a counter, with a prescale value other than 1:1 and operating the ECCP in Compare mode with the Special Event Trigger (CCP1CON bits, CCP1M3:CCP1M0 = 1011), the Special Event Trigger Reset of the timer occurs as soon as there is a match between TMRxH:TMRxL and CCPR1H:CCPR1L.

This differs from the PIC18F452, where the Special Event Trigger Reset of the timer occurs on the next prescaler output pulse after the match between TMRxH:TMRxL and CCPR1H:CCPR1L.

Work around

To achieve the same timer Reset period on the PIC18F4510 family as the PIC18F452 family for a given clock source, add 1 to the value in CCPR1H:CCPR1L. In other words, if CCPR1H:CCPR1L = x for the PIC18F452, to achieve the same Reset period on the PIC18F4510 family, use CCPR1H:CCPR1L = x + 1, where the prescale is 1, 2, 4 or 8 depending on the T1CKPS1:T1CKPS0 bit values.

Date Codes that pertain to this issue:

All engineering and production devices.

13. Module: ECCP

When a shutdown condition occurs, the output port(s) is made inactive for the duration of the event. After the event that caused the shutdown ends, the ECCP module enables the PWM output right away instead of waiting until the beginning of the next PWM cycle.

Work around

Disable the auto-restart feature in software, polling the Timer2 Interrupt Flag, TMR2IF, and wait until it is set before clearing the ECCPASE bit.

Date Codes that pertain to this issue:

All engineering and production devices.

14. Module: ECCP

When switching direction in Full-Bridge PWM mode, the modulated outputs will switch immediately instead of waiting for the next PWM cycle. This may generate unexpected short pulses on the modulated outputs.

Work around

Disable the PWM or set duty cycle to zero prior to switching directions.

Date Codes that pertain to this issue:

All engineering and production devices.

15. Module: EUSART

When performing back-to-back transmission in 9-bit mode (TX9D bit in the TXSTA register is set), an ongoing transmission's timing can be corrupted if the TX9D bit (for the next transmission) is not written immediately following the setting of TXIF. This is because any write to the TXSTA register results in a reset of the baud rate timer which will effect any ongoing transmission.

Work around

Load TX9D just after TXIF is set, either by polling TXIF or by writing TX9D at the beginning of the Interrupt Service Routine, or only write to TX9D when a transmission is not in progress (TRMT = 1).

Date Codes that pertain to this issue:

All engineering and production devices.

16. Module: EUSART

When performing back-to-back transmission in 9-bit mode (TX9D bit in the TXSTA register is set), the second byte may be corrupted if it is written into TXREG immediately after the TMRT bit is set.

Work around

Execute a software delay, at least one half the transmission's bit time, after TMRT is set and prior to writing subsequent bytes into TXREG.

Date Codes that pertain to this issue:

All engineering and production devices.

17. Module: Timer1/Timer3

When Timer1 or Timer3 is configured for the external clock source and the CCPxCON register is configured with 0x0B (Compare mode, trigger special event), the timer is not reset on a Special Event Trigger.

Work around

Modify firmware to reset the Timer registers upon detection of the compare match condition – TMRxL and TMRxH.

Date Codes that pertain to this issue:

All engineering and production devices.

18. Module: Timer1/Timer3

When Timer1 or Timer3 is in External Clock Synchronized mode and the external clock period is between 1 and 2 Tcy, interrupts will occasionally be skipped.

Work around

Avoid using an external clock with a period (1/frequency) between 1 and 2 Tcy.

Date Codes that pertain to this issue:

All engineering and production devices.

19. Module: Timer1/Timer3

When Timer1/Timer3 is operating in 16-bit mode and the prescale setting is not 1:1, a write to the TMR1H/TMR3H Buffer registers may lengthen the duration of the period between the increments of the timer for the period in which TMR1H/TMR3H were written.

Work around

Two work arounds are available: 1) Stop Timer1/Timer3 before writing the TMR1H/TMR3H registers; 2) Write TMR1L/TMR3L immediately after writing TMR1H/TMR3H.

Date Codes that pertain to this issue:

All engineering and production devices.

PIC18F2410/2510/4410/4510

20. Module: Interrupts

If an interrupt occurs during a two-cycle instruction that modifies the STATUS, BSR or WREG register, the unmodified value of the register will be saved to the corresponding Fast Return (Shadow) register, and upon a fast return from the interrupt, the unmodified value will be restored to the STATUS, BSR or WREG register.

For example, if a high priority interrupt occurs during the instruction, `MOVFF TEMP, WREG`, the `MOVFF` instruction will be completed and WREG will be loaded with the value of TEMP before branching to ISR. However, the previous value of WREG will be saved to the Fast Return register during ISR branching. Upon return from the interrupt with a fast return, the previous value of WREG in the Fast Return register will be written to WREG. This results in WREG containing the value it had before execution of `MOVFF TEMP, WREG`.

Affected instructions are:

```
MOVFF Fs, Fd  
where Fd is WREG, BSR or STATUS;
```

```
MOVSF Zs, Fd  
where Fd is WREG, BSR or STATUS; and
```

```
MOVSS [Zs], [Zd]  
where the destination is WREG, BSR or STATUS.
```

Work around

1. Assembly Language Programming:
 - a) If any two-cycle instruction is used to modify the WREG, BSR or STATUS register, do not use the `RETFIE FAST` instruction to return from the interrupt. Instead, save/restore WREG, BSR and STATUS via software per Example 8-1 in the Device Data Sheet. Alternatively, in the case of `MOVFF`, use the `MOVF` instruction to write to WREG instead. For example, use:

```
MOVF    TEMP, W  
MOVWF  BSR
```

instead of `MOVFF TEMP, BSR`.
 - b) As another alternative, the following work around shown in Example 2 can be used. This example overwrites the Fast Return register by making a dummy call to `Foo` with the fast option in the high priority service routine.

Date Codes that pertain to this issue:

All engineering and production devices.

EXAMPLE 2:

```
ISR @ 0x0008  
  CALL    Foo, FAST      ; store current value of WREG, BSR, STATUS for a second time  
Foo:  
  POP     ; clears return address of Foo call  
  :      ; insert high priority ISR code here  
  :  
  RETFIE  FAST
```

PIC18F2410/2510/4410/4510

2. C Language Programming: The exact work around depends on the compiler in use. Please refer to your C compiler documentation for details.

If using the Microchip MPLAB® C18 C Compiler, define both high and low priority interrupt handler functions as “low priority” by using the `pragma interruptlow` directive. This

directive instructs the compiler to not use the `RETFIE FAST` instruction. If the proper high priority interrupt bit is set in the IPRx register, then the interrupt is treated as high priority in spite of the `pragma interruptlow` directive.

The code segment shown in Example 3 demonstrates the work around using the C18 compiler:

EXAMPLE 3:

```
#pragma interruptlow MyLowISR
void MyLowISR(void)
{
    // Handle low priority interrupts.
}

// Although MyHighISR is a high priority interrupt, use interruptlow pragma so that
// the compiler will not use retfie FAST.

#pragma interruptlow MyHighISR
void MyHighISR(void)
{
    // Handle high priority interrupts.
}

#pragma code highVector=0x08
void HighVector (void)
{
    _asm goto MyHighISR _endasm
}
#pragma code /* return to default code section */

#pragma code lowVector=0x18
void LowVector (void)
{
    _asm goto MyLowISR _endasm
}
#pragma code /* return to default code section */
```

An optimized C18 version is also provided in Example 4. This example illustrates how it reduces the instruction cycle count from 10 cycles to 3:

EXAMPLE 4:

```
#pragma code high_vector_section=0x8
void high_vector (void)
{
    _asm
        _CALL high_vector_branch, 1
    _endasm
}

void high_vector_branch (void)
{
    _asm
        POP
        GOTO high_isr
    _endasm
}

#pragma interrupt high_isr
void high_isr (void)
{
    ...
}
```

PIC18F2410/2510/4410/4510

21. Module: A/D

The A/D offset is greater than the specified limit in Table 25-24 of the Device Data Sheet. The updated conditions and limits are shown in **bold** text in Table 2.

Work around

Three work arounds exist.

1. Configure the A/D to use the VREF+ and VREF- pins for the voltage references. This is done by setting the VCFG<1:0> bits (ADCON1<5:4>).
2. Perform a conversion on a known voltage reference voltage and adjust the A/D result in software.
3. Increase system clock speed to 40 MHz and adjust A/D settings accordingly. Higher system clock frequencies decrease offset error.

Date Codes that pertain to this issue:

All engineering and production devices.

TABLE 2: A/D CONVERTER CHARACTERISTICS: PIC18F2410/2510/4410/4510 (INDUSTRIAL)

Param No.	Symbol	Characteristic	Min	Typ	Max	Units	Conditions
A06A	E _{OFF}	Offset Error	—	—	<±2.0	LSb	VREF = VREF+ and VREF-
A06	E _{OFF}	Offset Error	—	—	<±3.5	LSb	VREF = Vss and VDD

22. Module: BOR

The BOR module may reset below the minimum operating voltage of the device when configured for BORV1:BORV0 = 11. The updated Reset voltage specifications are shown in **bold** in Table 3.

TABLE 3: BROWN-OUT RESET VOLTAGE

Param No.	Sym	Characteristic	Min	Typ	Max	Unit	
D005	V _{BOR}	Brown-out Reset Voltage					
		PIC18LF2525/2620/4525/4620					
		BORV1:BORV0 = 11	N/A	2.05	N/A	V	

Work around

Use the next higher BOR voltage setting to ensure a low V_{DD} is detected above 2.0V.

Date Codes that pertain to this issue:

All engineering and production devices.

23. Module: EUSART

The EUSART auto-baud feature may periodically measure the incoming baud rate incorrectly. The rate of incorrect baud rate measurements will depend on the frequency of the incoming synchronization byte and the system clock frequency.

Work around

None.

Date Codes that pertain to this issue:

All engineering and production devices.

24. Module: EUSART

In Synchronous mode (SYNC = 1) with clock polarity high (SCKP = 1), the EUSART transmits a shorter than expected clock on the CK pin for bit 0.

Work around

None.

Date Codes that pertain to this issue:

All engineering and production devices.

25. Module: EUSART

In Synchronous mode, EUSART baud rates using SPBRG values of '0' and '1' may not function correctly.

Work around

Use another baud rate configuration to generate the desired baud rate.

Date Codes that pertain to this issue:

All engineering and production devices.

26. Module: EUSART

During an auto-baud operation, the TX pin is tri-stated. Transceivers which do not provide a pull-up on the TX signal may cause the bus to become inadvertently active and prevent additional bus activity.

Work around

None.

Date Codes that pertain to this issue:

All engineering and production devices.

27. Module: MSSP

In an I²C system with multiple slave nodes, an unaddressed slave may respond to bus activity when data on the bus matches its address. The first occurrence will set the BF bit. The second occurrence will set the BF and the SSPOV bits. In both situations, the SSPIF bit is not set and an interrupt will not occur. The device will vector to the Interrupt Service Routine only if the interrupt is enabled and an address match occurs.

Work around

The I²C slave must clear the SSPOV bit after each I²C event to maintain normal operation.

Date Codes that pertain to this issue:

All engineering and production devices.

28. Module: MSSP

In I²C Master mode, the BRG value of '0' may not work correctly.

Work around

Use a BRG value greater than '0' by setting SSPADD ≥ 1.

Date Codes that pertain to this issue:

All engineering and production devices.

29. Module: MSSP

In I²C Master mode, the RCEN bit is set by software to begin data reception and cleared by the peripheral after a byte is received. After a byte is received, the device may take up to 80 T_{CY} to clear RCEN and 800 T_{CY} during emulation.

Work around

Single byte receptions are typically not affected, since the delay between byte receptions typically is long enough for the RCEN bit to clear. For multiple byte receptions, the software must wait until the bit is cleared by the peripheral before the next byte can be received.

Date Codes that pertain to this issue:

All engineering and production devices.

30. Module: MSSP

Setting the SEN bit initiates a Start sequence on the bus, after which, the SEN bit is cleared automatically by hardware. If the SEN bit is set again (without an address byte being transmitted), a Start sequence will not commence and the SEN bit will not be cleared. This condition causes the bus to remain in an active state. The system is idle when ACKEN, RCEN, PEN, RSEN, and SEN are clear.

Work around

Set the PEN or RSEN bit to transmit a Stop or Repeated Start sequence, although the SEN bit may still be set, indicating the bus is active. After the sequence has completed, the PEN, RSEN and SEN bit will be clear, indicating the bus is idle. Clearing and setting the SSPEN bit will also reset the I²C peripheral and clear the PEN, RSEN and SEN Status bits.

Date Codes that pertain to this issue:

All engineering and production devices.

PIC18F2410/2510/4410/4510

31. Module: MSSP

In SPI mode, the Buffer Full flag (BF bit in the SSPSTAT register), the Write Collision Detect bit (WCOL bit in SSPCON1) and the Receive Overflow Indicator bit (SSPOV in SSPCON1) are not reset upon disabling the SPI module (by clearing the SSPEN bit in the SSPCON1 register).

For example, if SSPBUF is full (BF bit is set) and the MSSP module is disabled and re-enabled, the BF bit will remain set. In SPI Slave mode, a subsequent write to SSPBUF will result in a write collision. Also, if a new byte is received, a receive overflow will occur.

Work around

Ensure that if the buffer is full, SSPBUF is read (thus clearing the BF flag) and WCOL is clear before disabling the MSSP module. If the module is configured in SPI Slave mode, ensure that the SSPOV bit is clear before disabling the module.

Date Codes that pertain to this issue:

All engineering and production devices.

32. Module: MSSP (SPI Mode)

When the SPI is using Timer2/2 as the clock source, a shorter than expected SCK pulse may occur on the first bit of the transmitted/received data (Figure 1).

FIGURE 1: SCK PULSE VARIATION USING TIMER2/2

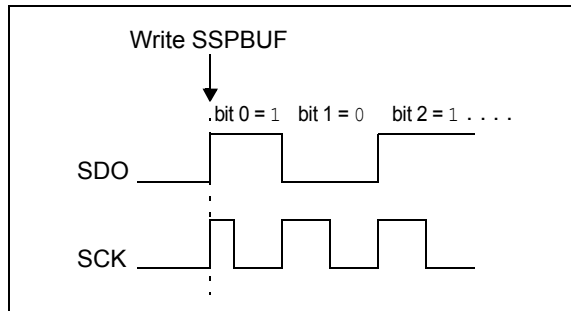

Work around

To avoid producing the short pulse, turn off Timer2 and clear the TMR2 register, load the SSPBUF with the data to transmit and then turn Timer2 back on. Refer to Example 5 for sample code.

EXAMPLE 5: AVOIDING THE INITIAL SHORT SCK PULSE

```
LOOP BTFSS SSPSTAT, BF      ;Data received?
                                ;(Xmit complete?)
    BRA    LOOP              ;No
    MOVF  SSPBUF, W          ;W = SSPBUF
    MOVWF RXDATA             ;Save in user RAM
    MOVF  TXDATA, W         ;W = TXDATA
    BCF   T2CON, TMR2ON     ;Timer2 off
    CLRF  TMR2              ;Clear Timer2
    MOVWF SSPBUF            ;Xmit New data
    BSF   T2CON, TMR2ON     ;Timer2 on
```

Date Codes that pertain to this issue:

All engineering and production devices.

33. Module: EUSART

In rare situations, one or more extra zero bytes have been observed in a packet transmitted by the module operating in Asynchronous mode. The actual data is not lost or corrupted; only unwanted (extra) zero bytes are observed in the packet.

This situation has only been observed when the contents of the transmit buffer, TXREG, are transferred to the TSR during the transmission of a Stop bit. For this to occur, three things must happen in the same instruction cycle:

- TXREG is written to;
- the baud rate counter overflows (at the end of the bit period); and
- a Stop bit is being transmitted (shifted out of TSR).

Work around

If possible, do not use the module's double-buffer capability. Instead, load the TXREG register when the TRMT bit (TXSTA<1>) is set, indicating the TSR is empty.

If double-buffering is used and back-to-back transmission is performed, then load TXREG immediately after TXIF is set or wait 1-bit time after TXIF is set. Both solutions prevent writing TXREG while a Stop bit is transmitted. Note that TXIF is set at the beginning of the Stop bit transmission.

If transmission is intermittent, then do the following:

- Wait for the TRMT bit to be set before loading TXREG.
- Alternatively, use a free timer resource to time the baud period. Set up the timer to overflow at the end of the Stop bit, then start the timer when you load the TXREG. Do not load the TXREG when the timer is about to overflow.

Date Codes that pertain to this issue:

All engineering and production devices.

34. Module: EUSART

In 9-Bit Asynchronous Full-Duplex Receive mode, the received data may be corrupted if the TX9D bit (TXSTA<0>) is not modified immediately after the RCIDL bit (BAUDCON<6>) is set.

Work around

Write to TX9D only when a reception is not in progress (RCIDL = 1). Since there is no interrupt associated with RCIDL, it must be polled in software to determine when TX9D can be updated.

Date Codes that pertain to this issue:

All engineering and production devices.

35. Module: EUSART

After the last received byte has been read from the EUSART receive buffer, RCREG, the value is no longer valid for subsequent read operations.

Work around

The RCREG register should only be read once for each byte received. After each byte is received from the EUSART, store the byte into a user variable. To determine when a byte is available to read from RCREG, poll the RCIDL bit (BAUDCON<6>) for a low-to-high transition, or use the EUSART Receive Interrupt, RCIF (PIR1<5>).

Date Codes that pertain to this issue:

All engineering and production devices.

36. Module: EUSART

With the auto-wake-up option enabled by setting the WUE (BAUDCON<1>) bit, the RCIF (PIR1<5>) bit will become set on a high-to-low transition on the RX pin. However, the WUE bit may not clear within 1 T_{CY} of a low-to-high transition on RX. While the WUE bit is set, reading the receive buffer, RCREG, will not clear the RCIF interrupt flag. Therefore, the first opportunity to automatically clear RCIF by reading RCREG may take longer than expected.

Note: RCIF can only be cleared by reading RCREG
--

Work around

There are two work arounds available:

1. Clear the WUE bit in software after the wake-up event has occurred prior to reading the receive buffer, RCREG.
2. Poll the WUE bit and read RCREG after the WUE bit is automatically cleared.

Date Codes that pertain to this issue:

All engineering and production devices.

PIC18F2410/2510/4410/4510

37. Module: Timer1

In 16-Bit Asynchronous Counter mode (with or without use of the Timer1 oscillator), the TMR1H and TMR3H buffers do not update when TMRxL is read.

This issue only affects reading the TMRxH registers. The timers increments and set the interrupt flags as expected. The timer registers can also be written as expected.

Work around

1. Use 8-bit mode by clearing the RD16 bit (T1CON<7>).
2. Use the internal clock synchronization option by clearing the T1SYNC bit (T1CON<2>).

Date Codes that pertain to this issue:

All engineering and production devices.

38. Module: MSSP

The MSSP configured in SPI slave mode will generate a write collision if SSPBUF is updated and the previous SSPBUF contents have not been transferred to the shift register.

Reinitializing the MSSP by clearing and setting the SSPEN (SSPCON1<5>) bit prior to rewriting SSPBUF will not prevent the error condition.

Work around

Prior to updating the SSPBUF register with a new value, verify whether the previous contents were transferred by reading the BF (SSPSTAT<0>) bit. If the previous byte has not been transferred, update SSPBUF and clear the WCOL (SSPCON1<7>) bit if necessary.

Date Codes that pertain to this issue:

All engineering and production devices.

39. Module: MSSP

In SPI mode, the SDO output may change after the inactive clock edge of the bit 0 output. This may affect some SPI components that read data over 300 ns after the inactive edge of SCK.

Work around

None

Date Codes that pertain to this issue:

All engineering and production devices.

40. Module: MSSP

It has been observed that, following a Power-on Reset, I²C mode may not initialize properly by just configuring the SCL and SDA pins as either inputs or outputs. This has only been seen in a few unique system environments.

A test of a statistically significant sample of pre-production systems, across the voltage and current range of the application's power supply, should indicate if a system is susceptible to this issue.

Work around

Before configuring the module for I²C operation:

1. Configure the SCL and SDA pins as outputs by clearing their corresponding TRIS bits.
2. Force SCL and SDA low by clearing the corresponding LAT bits.
3. While keeping the LAT bits clear, configure SCL and SDA as inputs by setting their TRIS bits.

Once this is done, use the SSPCON1 and SSPCON2 registers to configure the proper I²C mode as before.

Date Codes that pertain to this issue:

All engineering and production devices.

41. Module: MSSP

When the MSSP is configured for SPI mode, the Buffer Full bit, BF (SSPSTAT<0>), should not be polled in software to determine when the transfer is complete.

Work around

Copy the SSPSTAT register into a variable and perform the bit test on the variable. In Example 6, SSPSTAT is copied into the working register where the bit test is performed.

EXAMPLE 6:

```
loop_MSB:
    MOVF    SSPSTAT, W
    BTFSS  WREG, BF
    BRA     loop_MSB
```

A second option is to poll the Master Synchronous Serial Port Interrupt Flag bit, SSPIF (PIR1<3>). This bit can be polled and will set when the transfer is complete.

Date Codes that pertain to this issue:

All engineering and production devices.

42. Module: Reset

This version of silicon does not support the functionality described in Note 1 of parameter D002 in **Section 25.1 “DC Characteristics: Supply Voltage”** of the data sheet. The RAM content may be altered during a Reset event if the following conditions are met.

- Device is accessing RAM.
- Asynchronous Reset (i.e., WDT, BOR or $\overline{\text{MCLR}}$) occurs when a write operation is being executed (start of a Q4 cycle).

Work around

None

Date Codes that pertain to this issue:

All engineering and production devices.

43. Module: 10-Bit Analog-to-Digital (A/D) Converter

When the A/D clock source is selected as 2 TOSC or RC (when ADCS2:ADCS0 = 000 or x11), in extremely rare cases, the EIL (Integral Linearity Error) and EDL (Differential Linearity Error) may exceed the data sheet specification at codes 511 and 512 only.

Work around

Select a different A/D clock source (4 TOSC, 8 TOSC, 16 TOSC, 32 TOSC, 64 TOSC) and avoid selecting the 2 TOSC or RC modes.

Date Codes that pertain to this issue:

All engineering and production devices.

PIC18F2410/2510/4410/4510

REVISION HISTORY

Rev A Document (06/2006)

First revision of this document.

Issues 1-4 (MSSP), 5-7 (ECCP), 8 (ECCP and CCP), 9-14 (ECCP), 15-16 (EUSART), 17-19 (Timer1/Timer3), 20 (Interrupts), 21 (A/D), 22 (BOR), 23-26 (EUSART), 27-31 (MSSP), 32 (MSSP – SPI Mode), 33-36 (EUSART), 37 (Timer1), 38-41 (MSSP) and 42 (Reset).

Rev B Document (10/2006)

Corrected Device IDs.

Rev C Document (8/2007)

Added silicon issue 43 (10-Bit A/D Converter).

Note the following details of the code protection feature on Microchip devices:

- Microchip products meet the specification contained in their particular Microchip Data Sheet.
- Microchip believes that its family of products is one of the most secure families of its kind on the market today, when used in the intended manner and under normal conditions.
- There are dishonest and possibly illegal methods used to breach the code protection feature. All of these methods, to our knowledge, require using the Microchip products in a manner outside the operating specifications contained in Microchip's Data Sheets. Most likely, the person doing so is engaged in theft of intellectual property.
- Microchip is willing to work with the customer who is concerned about the integrity of their code.
- Neither Microchip nor any other semiconductor manufacturer can guarantee the security of their code. Code protection does not mean that we are guaranteeing the product as "unbreakable."

Code protection is constantly evolving. We at Microchip are committed to continuously improving the code protection features of our products. Attempts to break Microchip's code protection feature may be a violation of the Digital Millennium Copyright Act. If such acts allow unauthorized access to your software or other copyrighted work, you may have a right to sue for relief under that Act.

Information contained in this publication regarding device applications and the like is provided only for your convenience and may be superseded by updates. It is your responsibility to ensure that your application meets with your specifications. MICROCHIP MAKES NO REPRESENTATIONS OR WARRANTIES OF ANY KIND WHETHER EXPRESS OR IMPLIED, WRITTEN OR ORAL, STATUTORY OR OTHERWISE, RELATED TO THE INFORMATION, INCLUDING BUT NOT LIMITED TO ITS CONDITION, QUALITY, PERFORMANCE, MERCHANTABILITY OR FITNESS FOR PURPOSE. Microchip disclaims all liability arising from this information and its use. Use of Microchip devices in life support and/or safety applications is entirely at the buyer's risk, and the buyer agrees to defend, indemnify and hold harmless Microchip from any and all damages, claims, suits, or expenses resulting from such use. No licenses are conveyed, implicitly or otherwise, under any Microchip intellectual property rights.

Trademarks

The Microchip name and logo, the Microchip logo, Accuron, dsPIC, KEELOQ, KEELOQ logo, microID, MPLAB, PIC, PICmicro, PICSTART, PRO MATE, rPIC and SmartShunt are registered trademarks of Microchip Technology Incorporated in the U.S.A. and other countries.

AmpLab, FilterLab, Linear Active Thermistor, Migratable Memory, MXDEV, MXLAB, SEEVAL, SmartSensor and The Embedded Control Solutions Company are registered trademarks of Microchip Technology Incorporated in the U.S.A.

Analog-for-the-Digital Age, Application Maestro, CodeGuard, dsPICDEM, dsPICDEM.net, dsPICworks, dsSPEAK, ECAN, ECONOMONITOR, FanSense, FlexROM, fuzzyLAB, In-Circuit Serial Programming, ICSP, ICEPIC, Mindi, MiWi, MPASM, MPLAB Certified logo, MPLIB, MPLINK, PICkit, PICDEM, PICDEM.net, PICLAB, PICtail, PowerCal, PowerInfo, PowerMate, PowerTool, REAL ICE, rLAB, Select Mode, Smart Serial, SmartTel, Total Endurance, UNI/O, WiperLock and ZENA are trademarks of Microchip Technology Incorporated in the U.S.A. and other countries.

SQTP is a service mark of Microchip Technology Incorporated in the U.S.A.

All other trademarks mentioned herein are property of their respective companies.

© 2007, Microchip Technology Incorporated, Printed in the U.S.A., All Rights Reserved.

 Printed on recycled paper.

**QUALITY MANAGEMENT SYSTEM
CERTIFIED BY DNV
== ISO/TS 16949:2002 ==**

Microchip received ISO/TS-16949:2002 certification for its worldwide headquarters, design and wafer fabrication facilities in Chandler and Tempe, Arizona; Gresham, Oregon and design centers in California and India. The Company's quality system processes and procedures are for its PIC® MCUs and dsPIC® DSCs, KEELOQ® code hopping devices, Serial EEPROMs, microperipherals, nonvolatile memory and analog products. In addition, Microchip's quality system for the design and manufacture of development systems is ISO 9001:2000 certified.



WORLDWIDE SALES AND SERVICE

AMERICAS

Corporate Office
2355 West Chandler Blvd.
Chandler, AZ 85224-6199
Tel: 480-792-7200
Fax: 480-792-7277
Technical Support:
<http://support.microchip.com>
Web Address:
www.microchip.com

Atlanta

Duluth, GA
Tel: 678-957-9614
Fax: 678-957-1455

Boston

Westborough, MA
Tel: 774-760-0087
Fax: 774-760-0088

Chicago

Itasca, IL
Tel: 630-285-0071
Fax: 630-285-0075

Dallas

Addison, TX
Tel: 972-818-7423
Fax: 972-818-2924

Detroit

Farmington Hills, MI
Tel: 248-538-2250
Fax: 248-538-2260

Kokomo

Kokomo, IN
Tel: 765-864-8360
Fax: 765-864-8387

Los Angeles

Mission Viejo, CA
Tel: 949-462-9523
Fax: 949-462-9608

Santa Clara

Santa Clara, CA
Tel: 408-961-6444
Fax: 408-961-6445

Toronto

Mississauga, Ontario,
Canada
Tel: 905-673-0699
Fax: 905-673-6509

ASIA/PACIFIC

Asia Pacific Office
Suites 3707-14, 37th Floor
Tower 6, The Gateway
Harbour City, Kowloon
Hong Kong
Tel: 852-2401-1200
Fax: 852-2401-3431

Australia - Sydney
Tel: 61-2-9868-6733
Fax: 61-2-9868-6755

China - Beijing
Tel: 86-10-8528-2100
Fax: 86-10-8528-2104

China - Chengdu
Tel: 86-28-8665-5511
Fax: 86-28-8665-7889

China - Fuzhou
Tel: 86-591-8750-3506
Fax: 86-591-8750-3521

China - Hong Kong SAR
Tel: 852-2401-1200
Fax: 852-2401-3431

China - Qingdao
Tel: 86-532-8502-7355
Fax: 86-532-8502-7205

China - Shanghai
Tel: 86-21-5407-5533
Fax: 86-21-5407-5066

China - Shenyang
Tel: 86-24-2334-2829
Fax: 86-24-2334-2393

China - Shenzhen
Tel: 86-755-8203-2660
Fax: 86-755-8203-1760

China - Shunde
Tel: 86-757-2839-5507
Fax: 86-757-2839-5571

China - Wuhan
Tel: 86-27-5980-5300
Fax: 86-27-5980-5118

China - Xian
Tel: 86-29-8833-7252
Fax: 86-29-8833-7256

ASIA/PACIFIC

India - Bangalore
Tel: 91-80-4182-8400
Fax: 91-80-4182-8422

India - New Delhi
Tel: 91-11-4160-8631
Fax: 91-11-4160-8632

India - Pune
Tel: 91-20-2566-1512
Fax: 91-20-2566-1513

Japan - Yokohama
Tel: 81-45-471- 6166
Fax: 81-45-471-6122

Korea - Daegu
Tel: 82-53-744-4301
Fax: 82-53-744-4302

Korea - Seoul
Tel: 82-2-554-7200
Fax: 82-2-558-5932 or
82-2-558-5934

Malaysia - Penang
Tel: 60-4-646-8870
Fax: 60-4-646-5086

Philippines - Manila
Tel: 63-2-634-9065
Fax: 63-2-634-9069

Singapore
Tel: 65-6334-8870
Fax: 65-6334-8850

Taiwan - Hsin Chu
Tel: 886-3-572-9526
Fax: 886-3-572-6459

Taiwan - Kaohsiung
Tel: 886-7-536-4818
Fax: 886-7-536-4803

Taiwan - Taipei
Tel: 886-2-2500-6610
Fax: 886-2-2508-0102

Thailand - Bangkok
Tel: 66-2-694-1351
Fax: 66-2-694-1350

EUROPE

Austria - Wels
Tel: 43-7242-2244-39
Fax: 43-7242-2244-393

Denmark - Copenhagen
Tel: 45-4450-2828
Fax: 45-4485-2829

France - Paris
Tel: 33-1-69-53-63-20
Fax: 33-1-69-30-90-79

Germany - Munich
Tel: 49-89-627-144-0
Fax: 49-89-627-144-44

Italy - Milan
Tel: 39-0331-742611
Fax: 39-0331-466781

Netherlands - Drunen
Tel: 31-416-690399
Fax: 31-416-690340

Spain - Madrid
Tel: 34-91-708-08-90
Fax: 34-91-708-08-91

UK - Wokingham
Tel: 44-118-921-5869
Fax: 44-118-921-5820