



**MPLAB[®] ICE 2000/4000
TRANSITION SOCKET
SPECIFICATION**

Note the following details of the code protection feature on Microchip devices:

- Microchip products meet the specification contained in their particular Microchip Data Sheet.
- Microchip believes that its family of products is one of the most secure families of its kind on the market today, when used in the intended manner and under normal conditions.
- There are dishonest and possibly illegal methods used to breach the code protection feature. All of these methods, to our knowledge, require using the Microchip products in a manner outside the operating specifications contained in Microchip's Data Sheets. Most likely, the person doing so is engaged in theft of intellectual property.
- Microchip is willing to work with the customer who is concerned about the integrity of their code.
- Neither Microchip nor any other semiconductor manufacturer can guarantee the security of their code. Code protection does not mean that we are guaranteeing the product as "unbreakable."

Code protection is constantly evolving. We at Microchip are committed to continuously improving the code protection features of our products. Attempts to break Microchip's code protection feature may be a violation of the Digital Millennium Copyright Act. If such acts allow unauthorized access to your software or other copyrighted work, you may have a right to sue for relief under that Act.

Information contained in this publication regarding device applications and the like is provided only for your convenience and may be superseded by updates. It is your responsibility to ensure that your application meets with your specifications. MICROCHIP MAKES NO REPRESENTATIONS OR WARRANTIES OF ANY KIND WHETHER EXPRESS OR IMPLIED, WRITTEN OR ORAL, STATUTORY OR OTHERWISE, RELATED TO THE INFORMATION, INCLUDING BUT NOT LIMITED TO ITS CONDITION, QUALITY, PERFORMANCE, MERCHANTABILITY OR FITNESS FOR PURPOSE. Microchip disclaims all liability arising from this information and its use. Use of Microchip's products as critical components in life support systems is not authorized except with express written approval by Microchip. No licenses are conveyed, implicitly or otherwise, under any Microchip intellectual property rights.

Trademarks

The Microchip name and logo, the Microchip logo, Accuron, dsPIC, KEELOQ, microID, MPLAB, PIC, PICmicro, PICSTART, PRO MATE, PowerSmart, rfPIC, and SmartShunt are registered trademarks of Microchip Technology Incorporated in the U.S.A. and other countries.

AmpLab, FilterLab, Migratable Memory, MXDEV, MXLAB, PICMASTER, SEEVAL, SmartSensor and The Embedded Control Solutions Company are registered trademarks of Microchip Technology Incorporated in the U.S.A.

Analog-for-the-Digital Age, Application Maestro, dsPICDEM, dsPICDEM.net, dsPICworks, ECAN, ECONOMONITOR, FanSense, FlexROM, fuzzyLAB, In-Circuit Serial Programming, ICSP, ICEPIC, Linear Active Thermistor, MPASM, MPLIB, MPLINK, MPSIM, PICKit, PICDEM, PICDEM.net, PICLAB, PICtail, PowerCal, PowerInfo, PowerMate, PowerTool, rLAB, rfPICDEM, Select Mode, Smart Serial, SmartTel, Total Endurance and WiperLock are trademarks of Microchip Technology Incorporated in the U.S.A. and other countries.

SQTP is a service mark of Microchip Technology Incorporated in the U.S.A.

All other trademarks mentioned herein are property of their respective companies.

© 2005, Microchip Technology Incorporated, Printed in the U.S.A., All Rights Reserved.

 Printed on recycled paper.

**QUALITY MANAGEMENT SYSTEM
CERTIFIED BY DNV
== ISO/TS 16949:2002 ==**

Microchip received ISO/TS-16949:2002 quality system certification for its worldwide headquarters, design and wafer fabrication facilities in Chandler and Tempe, Arizona and Mountain View, California in October 2003. The Company's quality system processes and procedures are for its PICmicro® 8-bit MCUs, KEELOQ® code hopping devices, Serial EEPROMs, microperipherals, nonvolatile memory and analog products. In addition, Microchip's quality system for the design and manufacture of development systems is ISO 9001:2000 certified.



Transition Socket Specification

INTRODUCTION

Transition sockets are devices that allow MPLAB® ICE 2000 and MPLAB ICE 4000 device adapters to interface to sockets on customer products that differ from the standard emulator adapter connection.

Embedded microcontrollers/microprocessors come in many different types of IC packages, (i.e., DIP, PLCC, SOIC, SSOP, MQFP, etc.). Typically, development cycle components are EPROM-based and, as a result, are provided in larger windowed package formats such as DIP or PLCC. Production components are primarily preprogrammed ROM, OTP or Flash-based and are often in very compact SOIC, SSOP, MQFP or PQFP package formats.

The MPLAB ICE solution is transition sockets. A transition socket is specifically designed to provide compatibility between two differing types of IC package formats.

Transition sockets are typically composed of two parts: the DIP adapter socket and the SOIC/SSOP header. The DIP adapter socket is designed to plug into the emulator system's DIP device adapter on one side and the header on the other. The header is then soldered down to the target application.

The QFP Adapter is a single part soldered directly to the target application and fits into the QFP device adapter.

WHY SHOULD I USE TRANSITION SOCKETS IN MY PRODUCT DESIGN?

There are two very significant advantages to using transition sockets:

1. Shorter product development cycle.
2. Reduced expense in the design, layout and prototype testing.

A typical product design cycle has two important phases: the prototype design phase and the production design phase. Traditionally, these phases were different simply because the prototype used a microcontroller with a different package type. However, with the availability of the transition sockets, the prototype design can be identical to the production design because a transition socket can be used to bridge the microcontroller package differences.

WHAT TRANSITION SOCKETS ARE CURRENTLY AVAILABLE?

Microchip Technology currently offers the transition sockets listed in the Table of Contents following this introductory section.

The *Product Selector Guide* (DS00148) lists the transition sockets available for each device adapter of the MPLAB ICE 2000 or 4000 System. For more on MPLAB ICE 2000 device adapters, see the *MPLAB ICE 2000 Processor Module and Device Adapter Specification* (DS51140). For more on MPLAB ICE 4000 device adapters, see the *MPLAB ICE 4000 Processor Module and Device Adapter Specification* (DS51298).

Please check the Microchip web site (www.microchip.com) for the most current version of all documents.

HOW CAN I OBTAIN MAXIMUM BENEFIT FROM THE USE OF TRANSITION SOCKETS?

Attention to component placement should be considered to provide adequate clearance for the transition socket interface to the PCB footprint. This is especially true for any tall components such as connector headers, radial components or voltage regulators. Refer to the transition socket mechanical drawings for dimensions.

TRANSITION SOCKET APPLICATIONS – COMMENTS AND SUGGESTIONS

Attention to component placement should be considered in mating the adapter sockets to the SOIC/SSOP headers. If visual alignment is difficult in your application, C-shaped end brackets have been included to aid in header-to-adapter socket alignment. Clip the brackets onto the SOIC/SSOP header.

The placement of via's around the Surface Mount Technology (SMT) layout area should be examined. Via's immediately adjacent to the end of a SMT pad may inadvertently come into contact with the header leads. Via's should be placed along the centerline of the SMT pad to lessen the chance of pin-to-pin shorts while soldering.

The SOIC header is designed for SOIC body width of 0.300-inch, the adapter leads should be cut to fit the 0.150-inch and 0.208-inch SOIC body widths.

For information on packaging dimensions, please refer to DS00049.



Table of Contents

PDIP Transition Socket

XLT28XP

28-lead DIP 0.300-inch Male to 0.600-inch Female Adapter Socket 7

SOIC Transition Socket

XLT08SO

8-lead DIP to 0.050-inch Adapter Socket 8

8-lead SOIC Header 8

XLT14SO

14-lead DIP to 0.050-inch Adapter Socket 9

14-lead SOIC Header 9

XLT18SO

18-lead DIP to 0.050-inch Adapter Socket 9

18-lead SOIC Header 9

XLT20SO1

20-lead DIP to 0.050-inch Adapter Socket 10

20-lead SOIC Header 10

XLT28SO

28-lead DIP to 0.050-inch Adapter Socket 10

28-lead SOIC Header 10

SSOP Transition Socket

XLT14SS

14-lead DIP to 0.8 mm Adapter Socket 11

14-lead SSOP Header 11

XLT20SS

18-lead DIP to 0.8 mm Adapter Socket 12

20-lead SSOP Header 12

XLT20SS1

20-lead DIP to 0.8 mm Adapter Socket 12

20-lead SSOP Header 12

XLT28SS, XLT28SS2

28-lead DIP to 0.8 mm Adapter Socket 13

28-lead SSOP Header 13

PLCC Transition Socket

XLT44L2, XLT68L1, XLT84L1

44/68/84-lead Transition Socket Top 15

44/68/84-lead Transition Socket Side 15

MPLAB® ICE 2000/4000

MQFP/TQFP Transition Socket

XLT44PT	
44-lead QFP to 0.8 mm Adapter Socket Top	17
44-lead QFP to 0.8 mm Adapter Socket Side	17
XLT64PT1, XLT64PT2, XLT80PT	
64/80-lead QFP to 0.5 mm Adapter Socket Top	17
64/80-lead QFP to 0.5 mm Adapter Socket Side	17
XLT64PT3	
64-lead QFP to 0.8mm Adapter Socket Top	18
64-lead QFP to 0.8mm Adapter Socket Side	18
XLT44PT3, XLT64PT4	
44/64-lead QFP to 0.8 mm Adapter Socket Top	18
44/64-lead QFP to 0.8 mm Adapter Socket Side	18
XLT64PT5, XLT80PT3	
64/80-lead QFP to 0.5 mm Adapter Socket Top	19
64/80-lead QFP to 0.5 mm Adapter Socket Side	19
XLT80PT2	
80-lead QFP to 0.65 mm Adapter Socket Top	19
80-lead QFP to 0.65 mm Adapter Socket Side	19

SOT/DFN/QFN Transition Sockets

XLT06SOT	
6-lead SOT-23 to 0.80-inch Adapter Socket	22
XLT08DFN2	
8/14-lead DIP to 0.025-inch Adapter Socket	22
XLT16QFN1, XLT28QFN3, XLT28QFN4, XLT44QFN2, XLT44QFN3	
14/28/44-lead DIP to 0.025-inch Adapter Socket Top	23
14/28/44-lead DIP to 0.025-inch Adapter Socket Side and Cables	23
XLT08DFN (Discontinued - see XLT08DFN2)	
8-lead DIP to 0.025-inch Adapter Socket	24
XLT28QFN (Discontinued - see XLT28QFN4)	
28-lead DIP to 0.025-inch Adapter Socket	24
XLT28QFN (Discontinued - see XLT28QFN4)	
28-lead DIP to 0.025-inch Adapter Socket	25
XLT28QFN2 (Discontinued - see XLT28QFN3)	
18-lead DIP to 0.025-inch Adapter Socket	25
XLT44QFN (Discontinued - see XLT44QFN2)	
40-lead DIP to 0.025-inch Adapter Socket	26
44-lead QFN Header	26

Transition Socket Specification

PDIP TRANSITION SOCKET

A PDIP transition socket and associated hardware is shown in Figure 1.

FIGURE 1: PDIP TRANSITION SOCKET

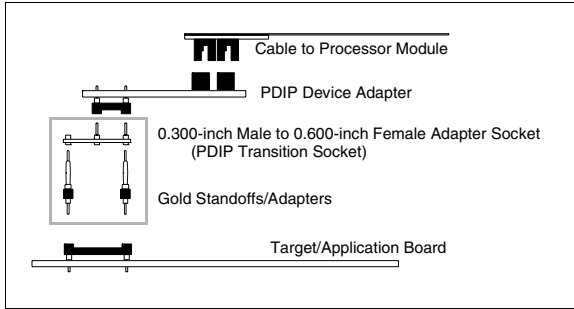

The PDIP transition socket is a 0.300-inch Male to 0.600-inch Female adapter socket.

Microchip offers the following PDIP transition socket:

- XLT28XP: One 28-lead PDIP adapter socket and two 28-lead gold stand-offs

See the drawings in this section for layout dimensions.

XLT28XP

28-lead DIP 0.300-inch Male to 0.600-inch Female Adapter Socket

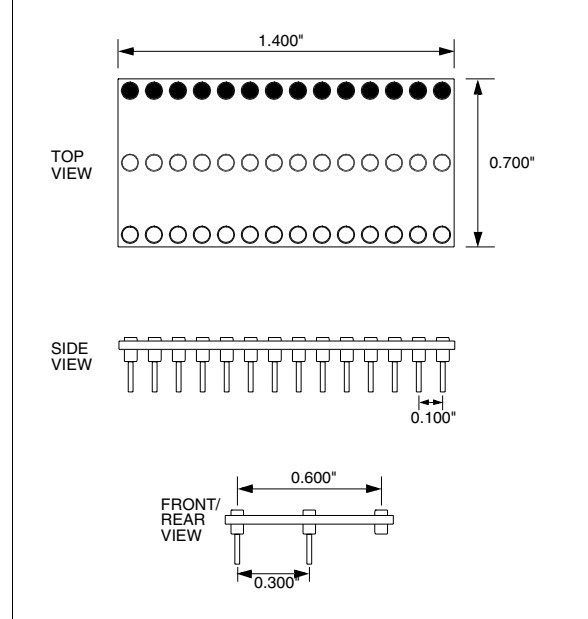

Transition Socket Specification

SOIC TRANSITION SOCKET

An SOIC transition socket and associated hardware is shown in Figure 2.

FIGURE 2: SOIC TRANSITION SOCKET

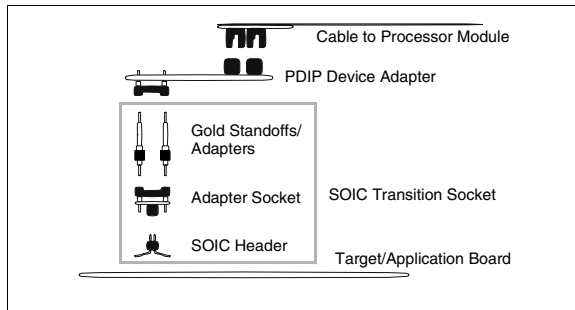

There are two components of the SOIC transition socket.

1. Adapter socket that connects to the PDIP device adapter.
2. SOIC header that is to be soldered down to the target application.

Microchip offers the following SOIC transition sockets:

- XLT08SO: One adapter socket and three 8-lead SOIC headers
- XLT14SO: One adapter socket and three 14-lead SOIC headers
- XLT18SO: One adapter socket and three 18-lead SOIC headers
- XLT20SO1: One adapter socket and three 20-lead SOIC headers
- XLT28SO: One adapter socket and three 28-lead SOIC headers

See the drawings in this section for layout dimensions.

Note: The SOIC header is designed for SOIC body width of 0.300 inch. The adapter leads should be cut to fit the 0.150-inch and 0.208-inch SOIC body widths.

XLT08SO

8-lead DIP to 0.050-inch Adapter Socket

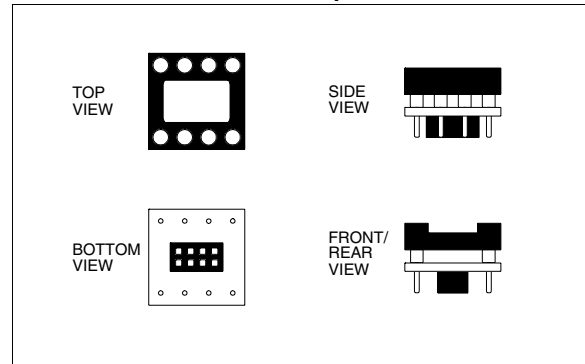

8-lead SOIC Header

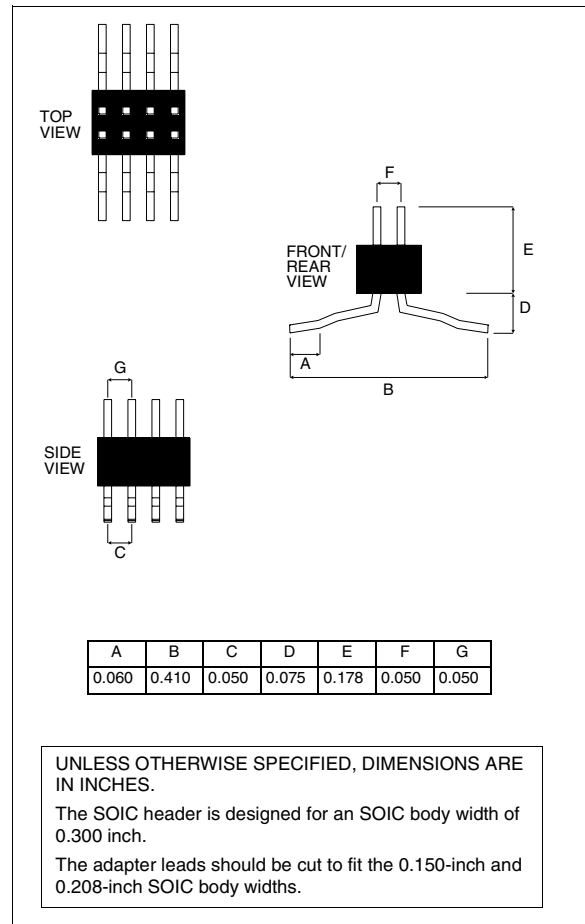

Transition Socket Specification

XLT14SO

14-lead DIP to 0.050-inch Adapter Socket

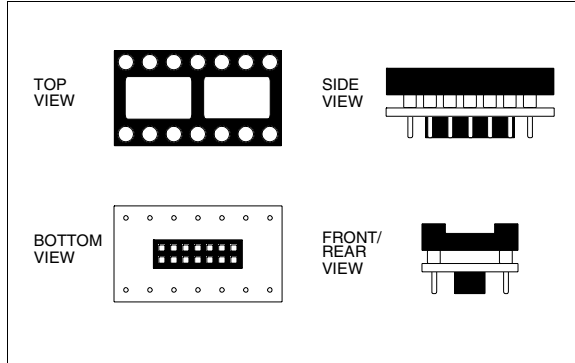

14-lead SOIC Header

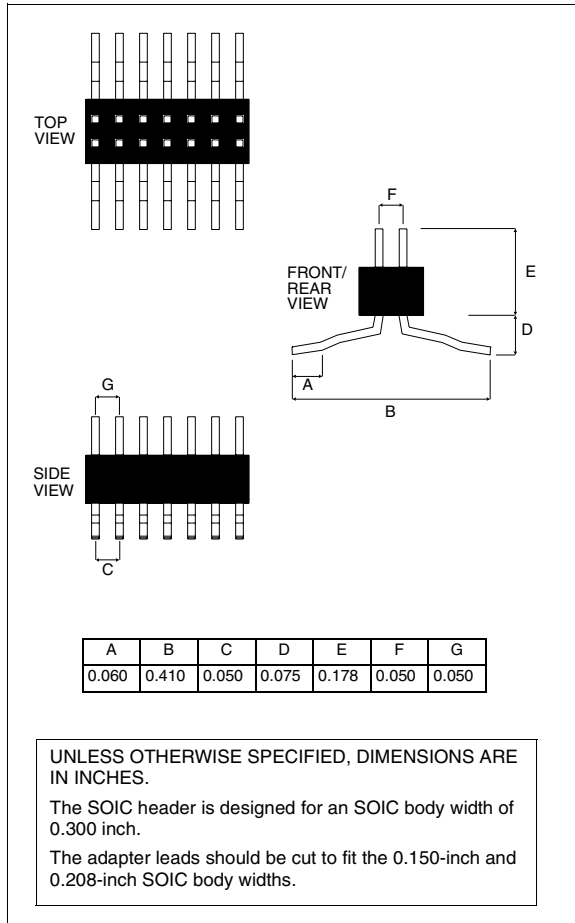

XLT18SO

18-lead DIP to 0.050-inch Adapter Socket

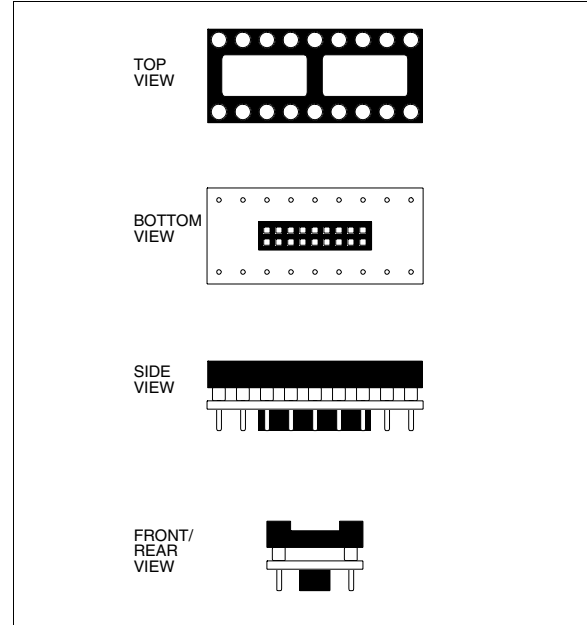

18-lead SOIC Header

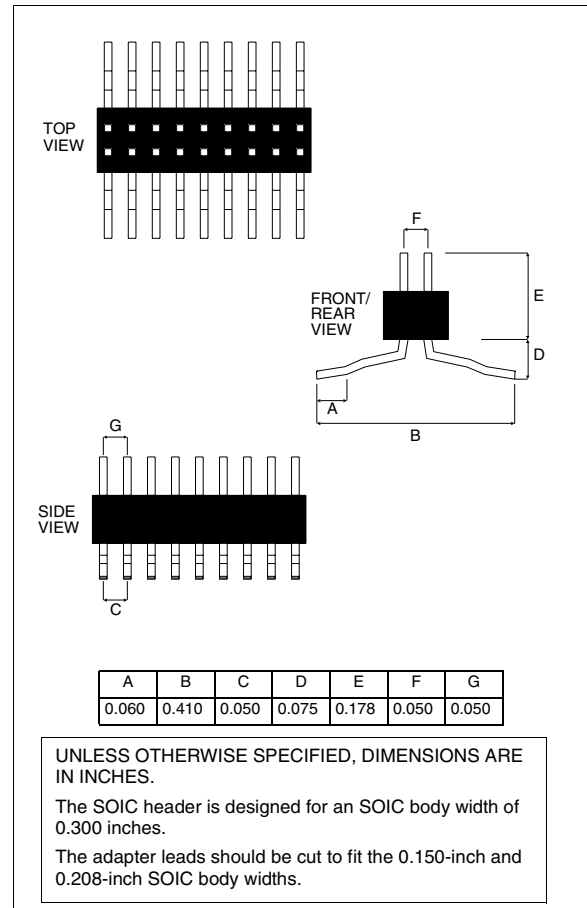

Transition Socket Specification

XLT20SO1

20-lead DIP to 0.050-inch Adapter Socket

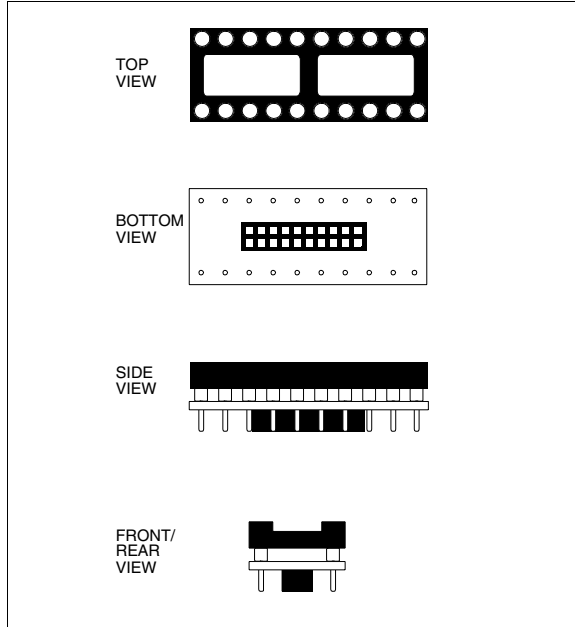

XLT28SO

28-lead DIP to 0.050-inch Adapter Socket

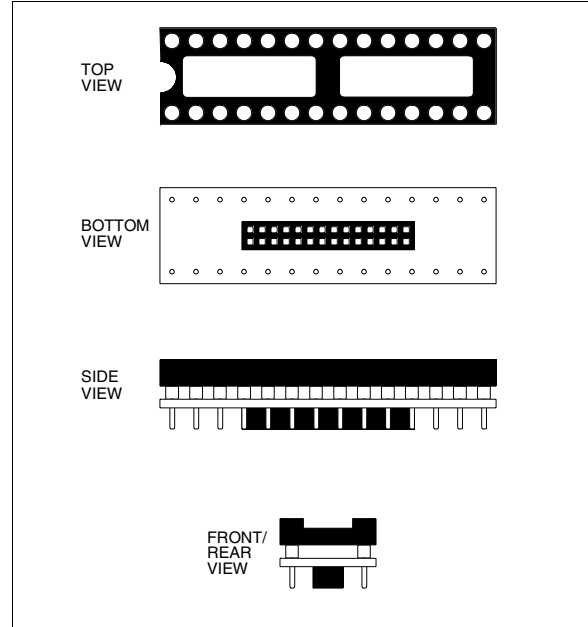

20-lead SOIC Header

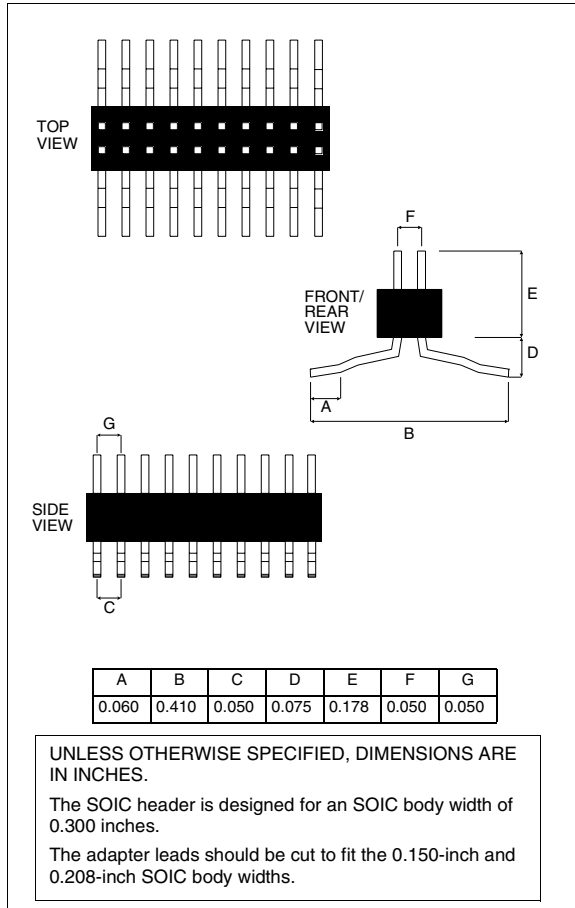

28-lead SOIC Header

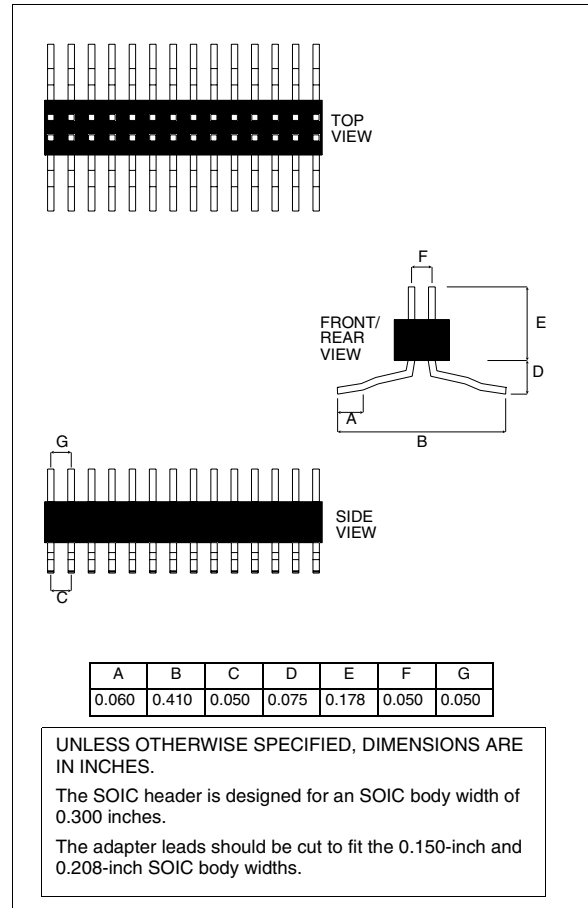

Transition Socket Specification

SSOP TRANSITION SOCKET

An SSOP transition socket and associated hardware is shown in Figure 3.

FIGURE 3: SSOP TRANSITION SOCKET

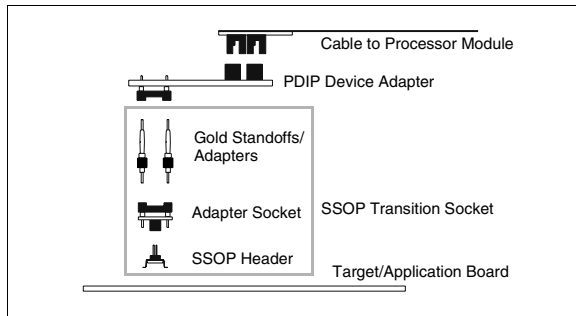

The SSOP transition sockets are similar to the SOIC transition sockets. There are two parts to the SSOP transition socket:

1. Adapter socket that connects to the PDIP device adapter.
2. SSOP header that gets soldered down to the target application.

Note: To keep the leads straight during assembly and shipping, the SSOP headers are shipped with break-away tabs attached to the leads. Please remove the break-away tabs before applying power to the target system. Be careful not to bend the leads prior to soldering to the target application.

Microchip offers the following SSOP transition sockets:

- XLT14SS: One adapter socket and three 14-lead SSOP headers
- XLT20SS: One adapter socket and three 20-lead SSOP headers
- XLT20SS1: One adapter socket and three 20-lead SSOP headers
- XLT28SS: One adapter socket and three 28-lead SSOP headers
- XLT28SS2: One adapter socket and three 28-lead SSOP headers for PIC16C55/57

See the drawings in this section for layout dimensions and clearances for tall components.

XLT14SS

14-lead DIP to 0.8 mm Adapter Socket

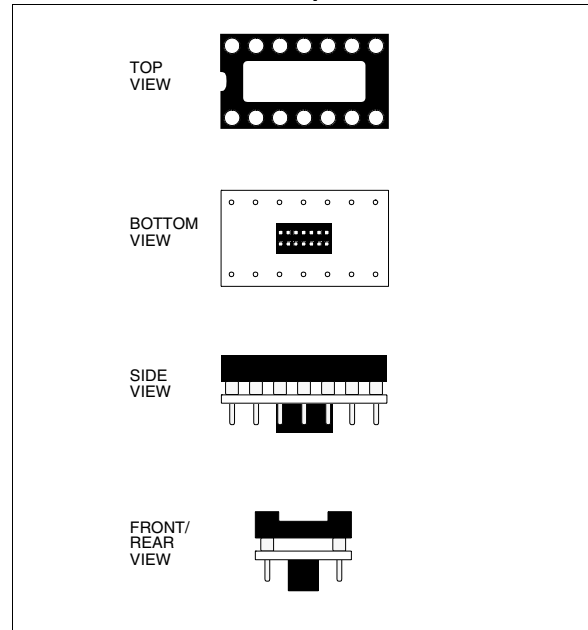

14-lead SSOP Header

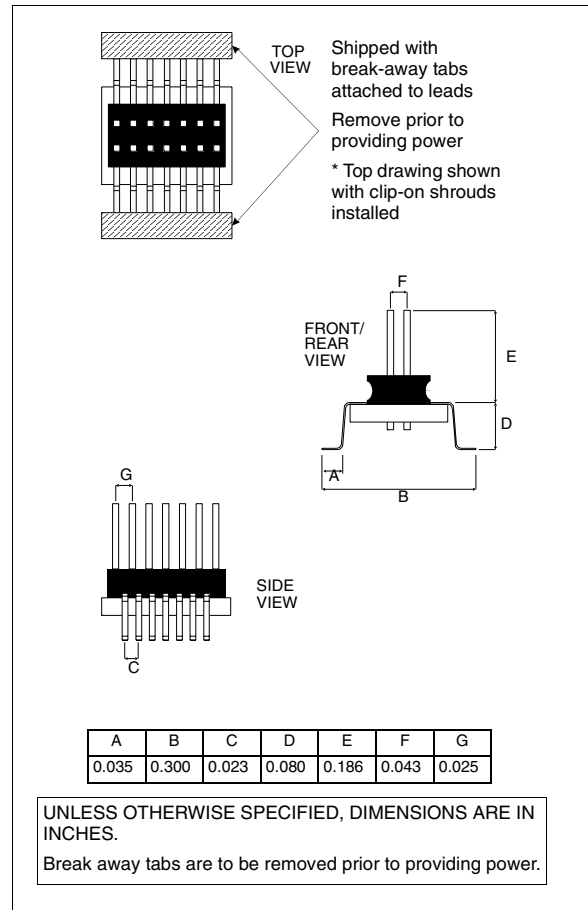

Transition Socket Specification

XLT20SS

18-lead DIP to 0.8 mm Adapter Socket

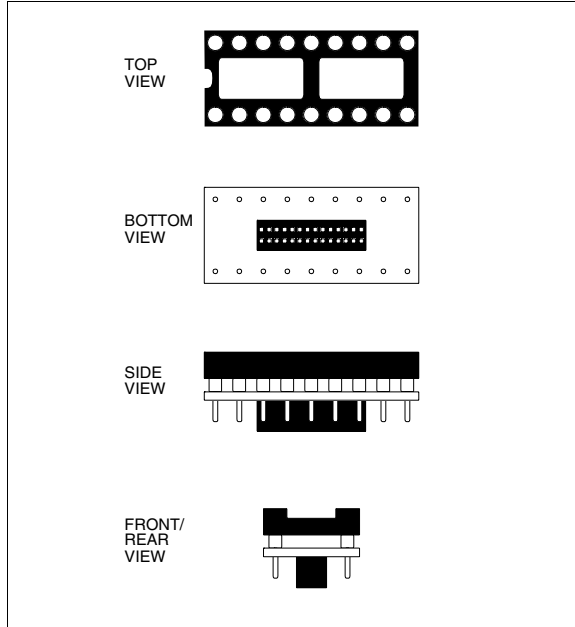

XLT20SS1

20-lead DIP to 0.8 mm Adapter Socket

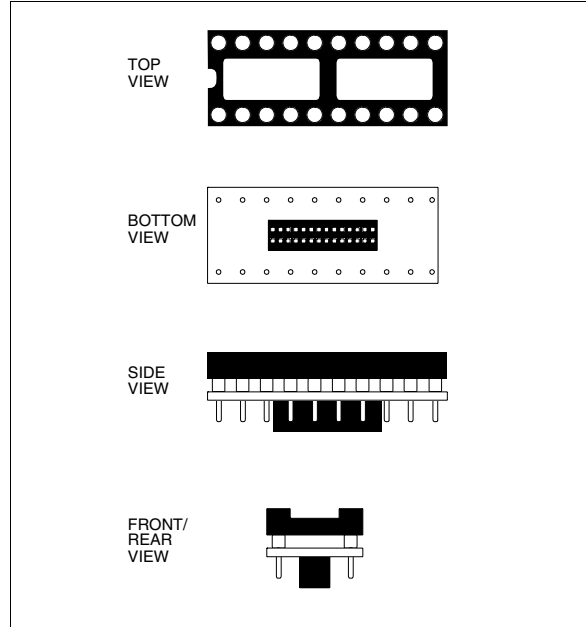

20-lead SSOP Header

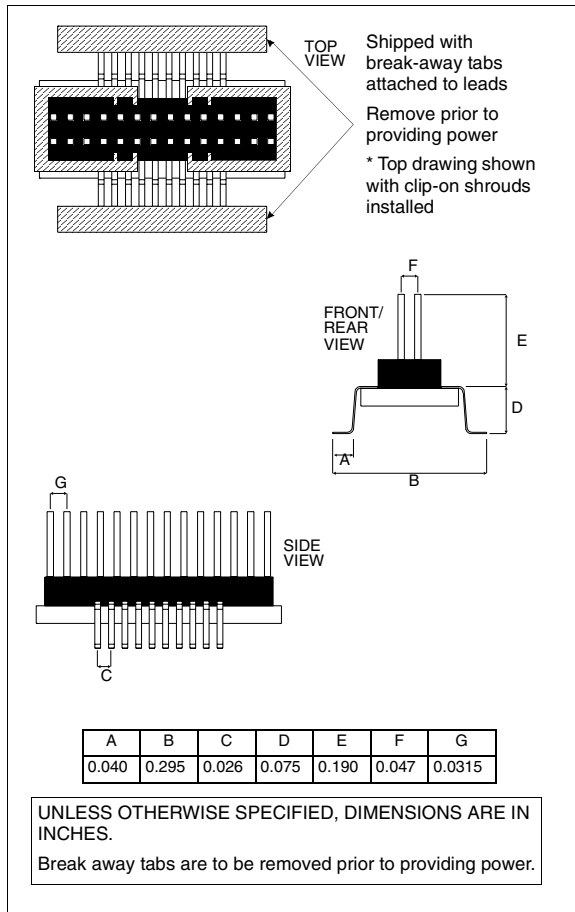

20-lead SSOP Header

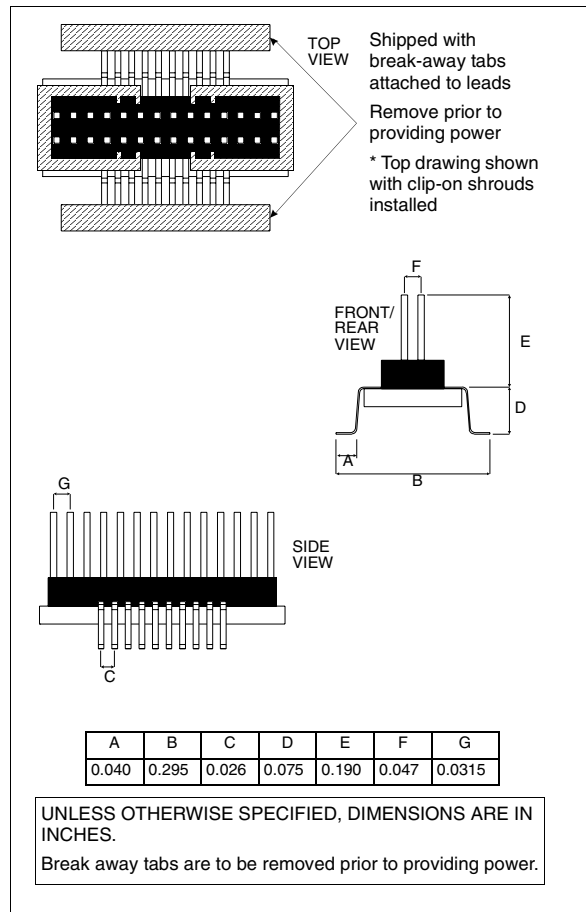

Transition Socket Specification

XLT28SS, XLT28SS2

28-lead DIP to 0.8 mm Adapter Socket

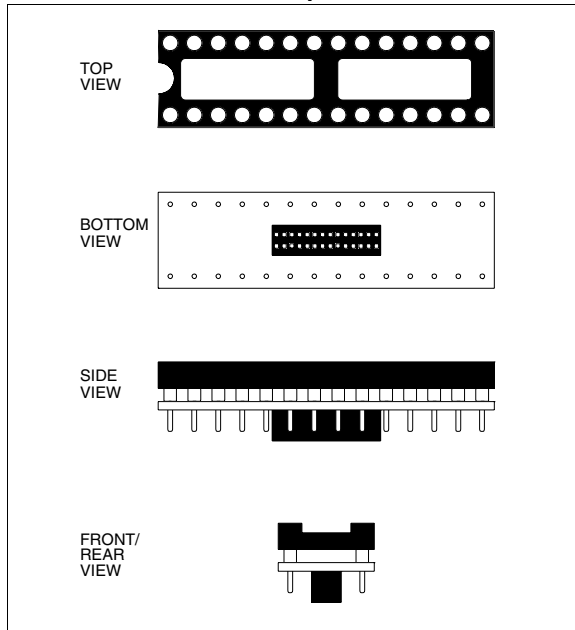

28-lead SSOP Header

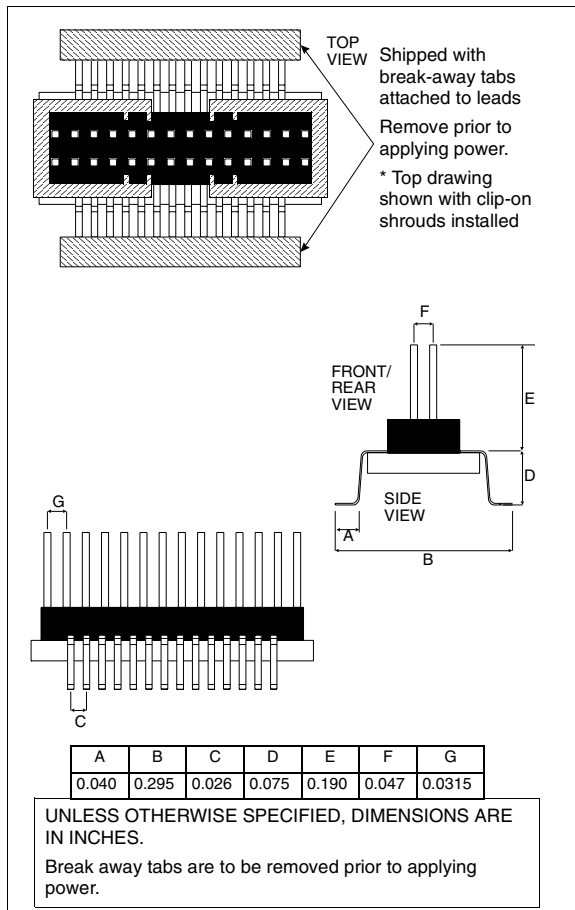

Transition Socket Specification

PLCC TRANSITION SOCKET

A PLCC transition socket and associated hardware is shown in Figure 4.

FIGURE 4: PLCC TRANSITION SOCKET

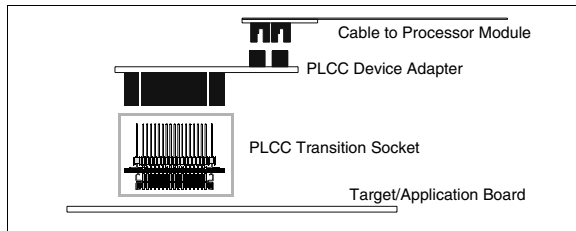

The PLCC transition socket is required for use along with the PLCC device adapters. The DAF18-1 device adapter is equipped with eight socket strips that interface with one of two transition sockets. The DAF18-3 device adapter is equipped with four socket strips that interface with one transition socket.

The PLCC transition sockets are designed with a threaded insert in the center of the footprint so that a 4/40 screw can securely fasten the transition socket to the device adapter.

The PLCC transition sockets are designed to be soldered to the target PCB PLCC surface mount pattern or inserted into a PLCC socket on the target PCB.

Note: To avoid solder bridging, do not place via's within 0.025-inch of the PLCC footprint. Also, any via's near the PLCC should be directly on the centerline of the pad.

Microchip offers the following PLCC transition sockets:

- XLT44L2: One 44-lead PLCC transition socket
- XLT68L1: One 68-lead PLCC transition socket
- XLT84L1: One 84-lead PLCC transition socket

RECOMMENDED PCB LAYOUT

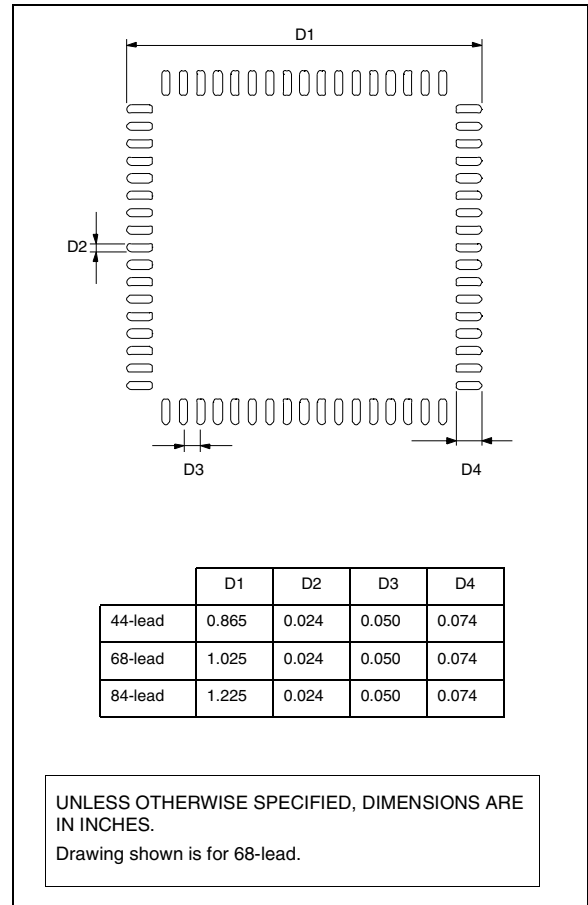

Transition Socket Specification

XLT44L2, XLT68L1, XLT84L1

44/68/84-lead Transition Socket Top

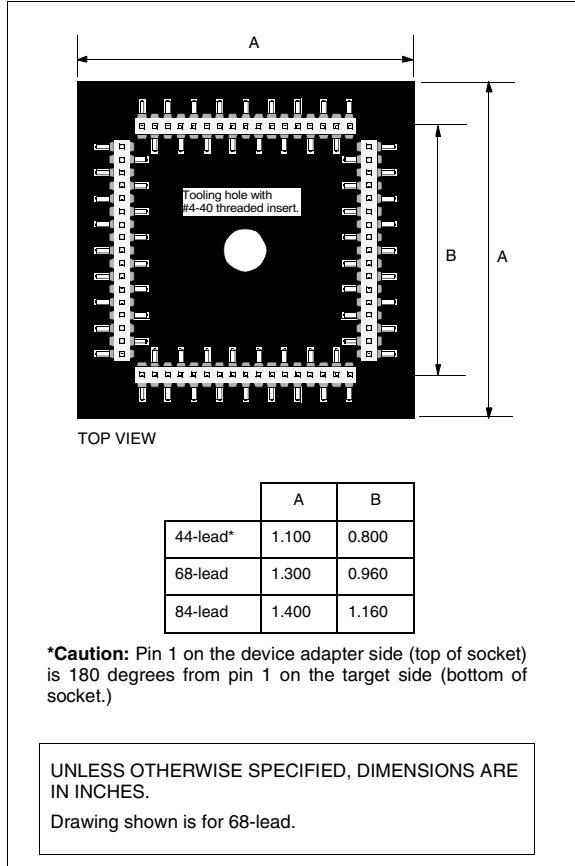

44/68/84-lead Transition Socket Side

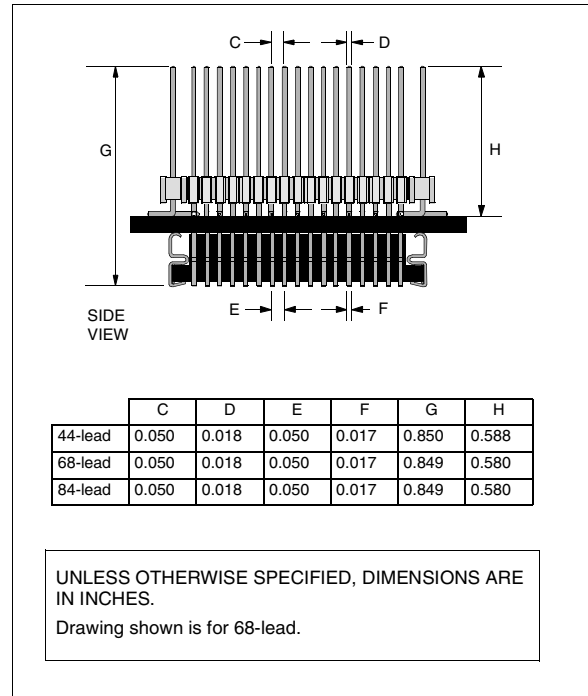

Transition Socket Specification

MQFP/TQFP TRANSITION SOCKET

MQFP/TQFP transition sockets and associated hardware is shown below.

FIGURE 5: MQFP/TQFP TRANSITION SOCKET

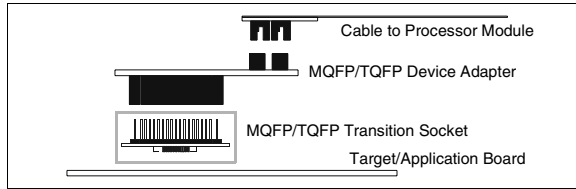
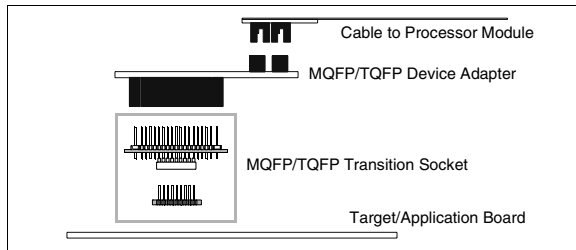

FIGURE 6: MQFP/TQFP TWO-PART TRANSITION SOCKET



The MQFP/TQFP transition socket is required for use along with the MQFP/TQFP device adapters. The device adapter is equipped with four socket strips that interface with the transition socket.

Note: To avoid solder bridging, do not place via's within 0.025-inch of the MQFP/TQFP footprint. Also, any via's near the MQFP/TQFP should be directly on the centerline of the pad.

Microchip offers the following MQFP/TQFP transition sockets:

- XLT44PT: One 44-lead MQFP/TQFP transition socket, 0.80 mm
- XLT44PT3: One 44-lead MQFP/TQFP two-part transition socket, 0.80 mm
- XLT64PT1: One 64-lead MQFP/TQFP transition socket, 0.5 mm (PIC16C92X)
- XLT64PT2: One 64-lead MQFP/TQFP transition socket, 0.5 mm (PIC17CXXX)
- XLT64PT3: One 64-lead MQFP/TQFP transition socket, 0.8 mm (dsPIC30F)
- XLT64PT4: One 64-lead MQFP/TQFP two-part transition socket, 0.8 mm
- XLT64PT5: One 64-lead MQFP/TQFP two-part transition socket, 0.5 mm
- XLT80PT: One 80-lead MQFP/TQFP transition socket, 0.5 mm
- XLT80PT2: One 80-lead MQFP/TQFP two-part transition socket, 0.65 mm
- XLT80PT3: One 80-lead MQFP/TQFP two-part transition socket, 0.5 mm

Note: The XLT64PT1 for the PIC16C92X is not symmetrical. Please note Pin 1 orientation prior to soldering to the target system.

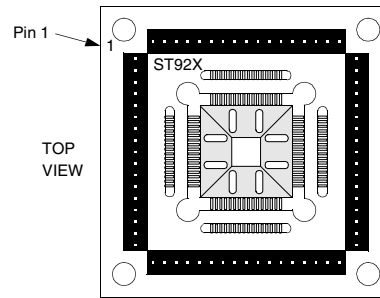

See the drawings in this section for layout dimensions and clearances for tall components.

TQFP TRANSITION SOCKET SOLDERING TIPS

- Before soldering, consider keeping the break away tabs in place during soldering.
- Use controlled soldering iron tip temperatures between 300°C and 325°C (570°F to 615°F)
- If possible, use a PACE mini wave soldering iron tip or an equivalent tip design.
- Plan to solder one (1 of 4) side first, then the opposite side, then remaining two sides.
- Soldering iron tip movement should be in direction of the leads (backward and forward), not across the leads; dragging the tip across the leads may cause lead damage.
- Use generous amounts of soldering flux to aid in the solder flow action.
- If the breakaway tabs are removed after soldering (using a dental pick or equivalent), any solder bridging between leads can be repaired by simply gently touching the soldering tip to the lead tip.

CAUTION

The 64- and 80-pin TQFP headers are very delicate and can be easily damaged!

Transition Socket Specification

XLT44PT

44-lead QFP to 0.8 mm Adapter Socket Top

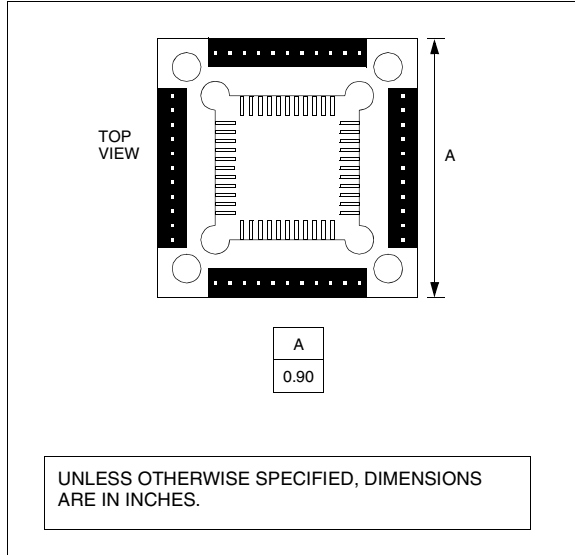

44-lead QFP to 0.8 mm Adapter Socket Side

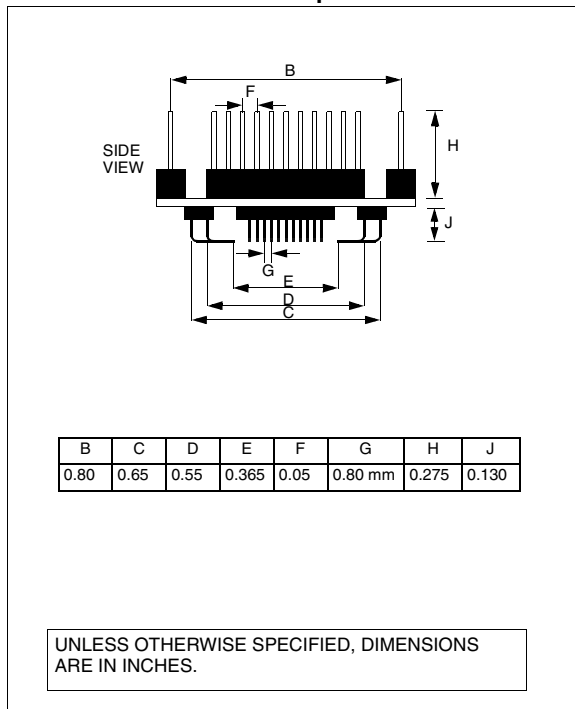

XLT64PT1, XLT64PT2, XLT80PT

64/80-lead QFP to 0.5 mm Adapter Socket Top

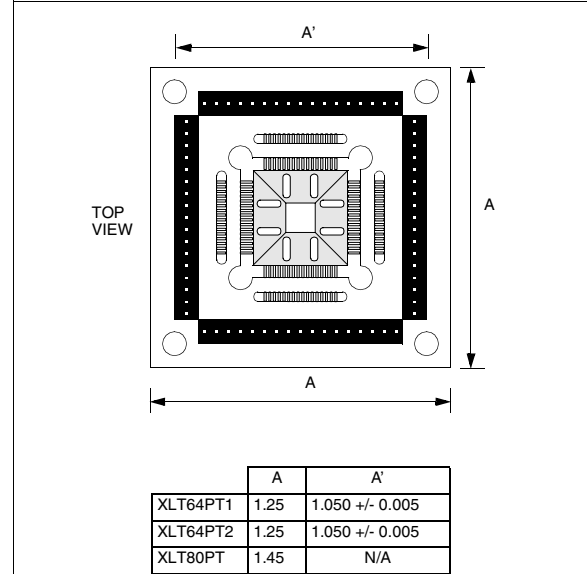

64/80-lead QFP to 0.5 mm Adapter Socket Side

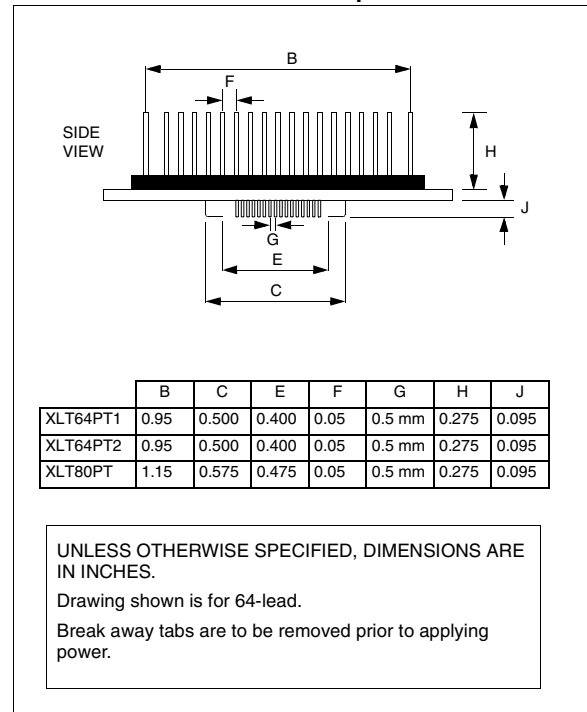

Transition Socket Specification

XLT64PT3

64-lead QFP to 0.8mm Adapter Socket Top

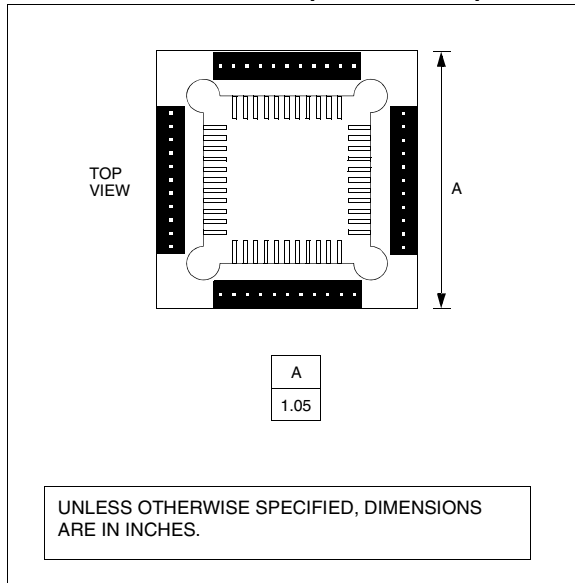

64-lead QFP to 0.8mm Adapter Socket Side

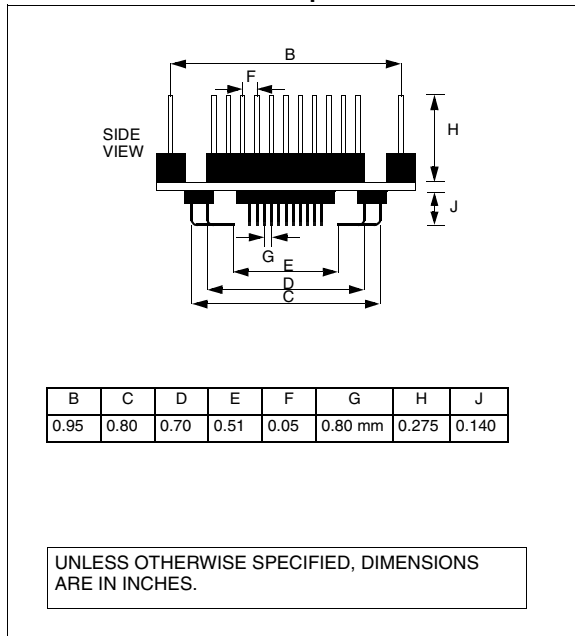

XLT44PT3, XLT64PT4

44/64-lead QFP to 0.8 mm Adapter Socket Top

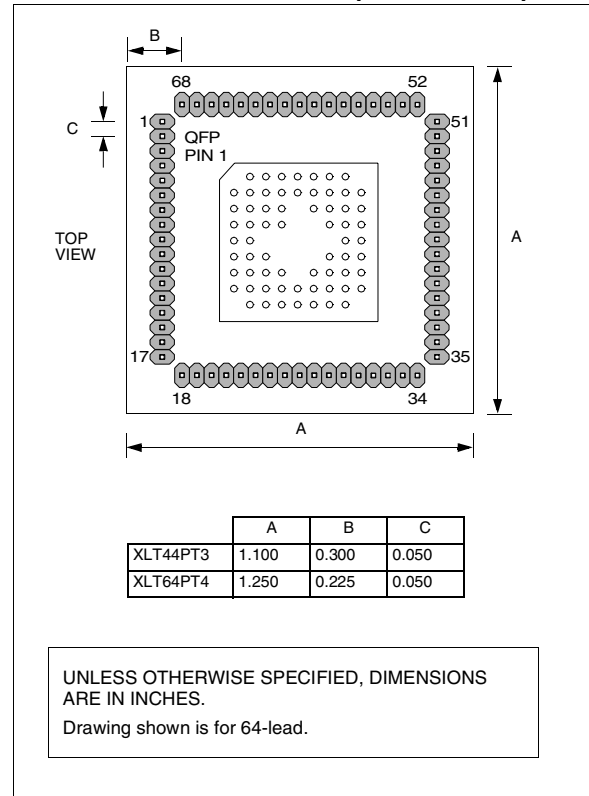

44/64-lead QFP to 0.8 mm Adapter Socket Side

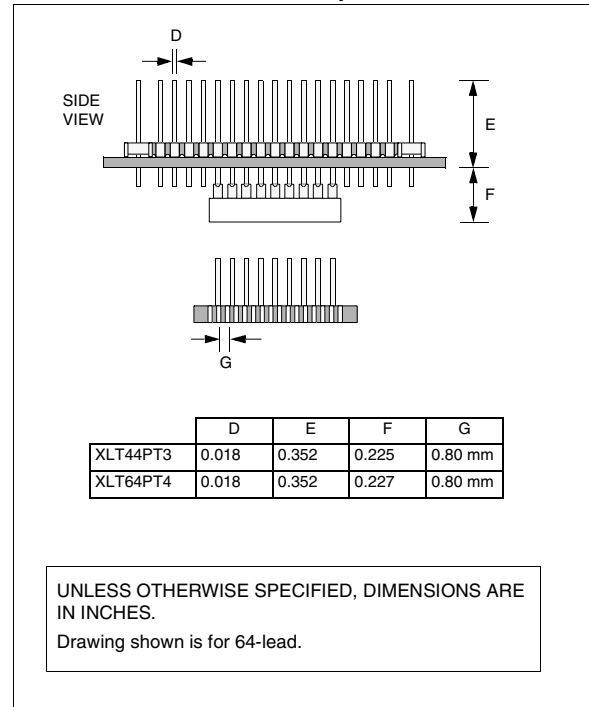

Transition Socket Specification

XLT64PT5, XLT80PT3

64/80-lead QFP to 0.5 mm Adapter Socket Top

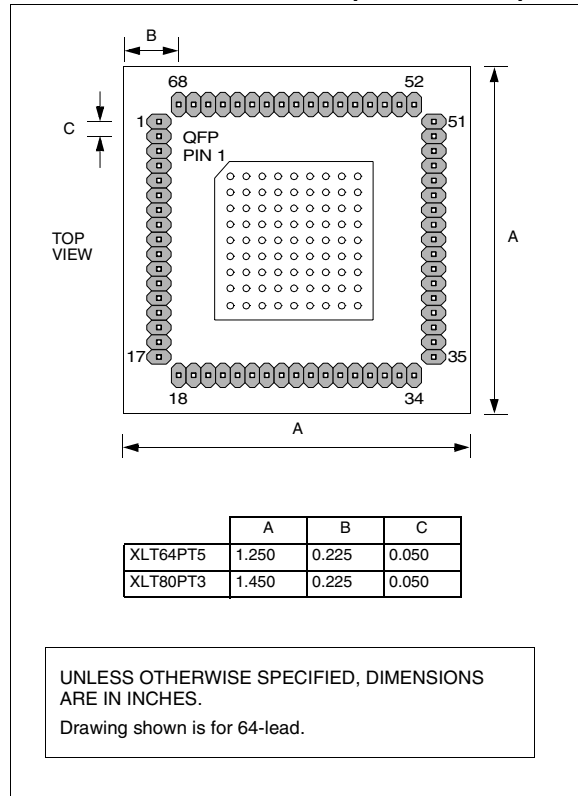

XLT80PT2

80-lead QFP to 0.65 mm Adapter Socket Top

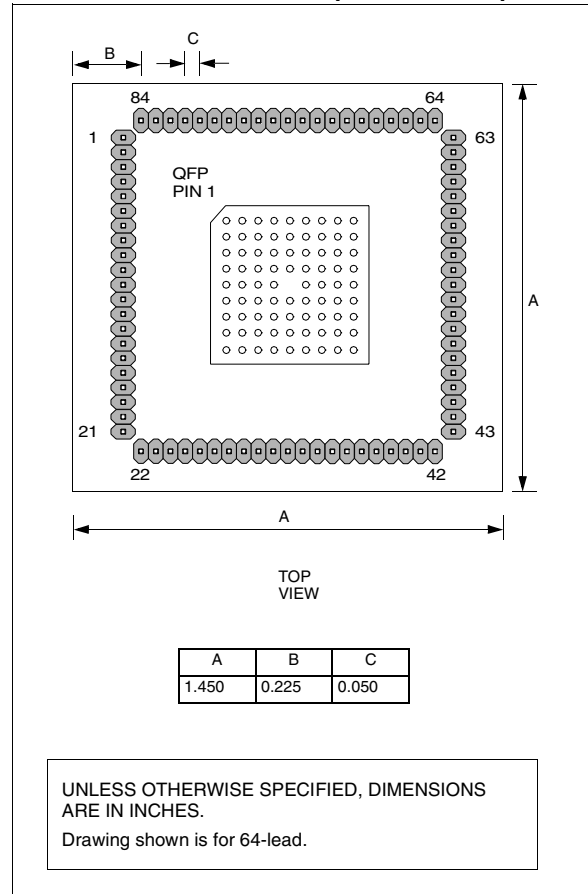

64/80-lead QFP to 0.5 mm Adapter Socket Side

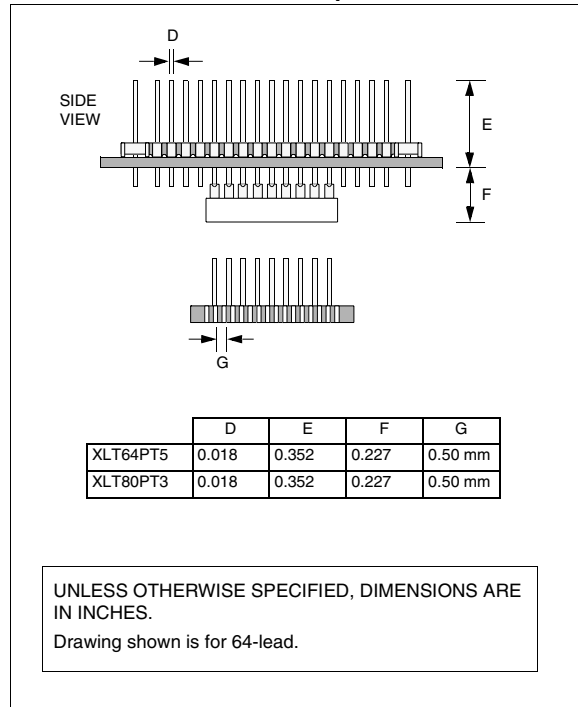

80-lead QFP to 0.65 mm Adapter Socket Side

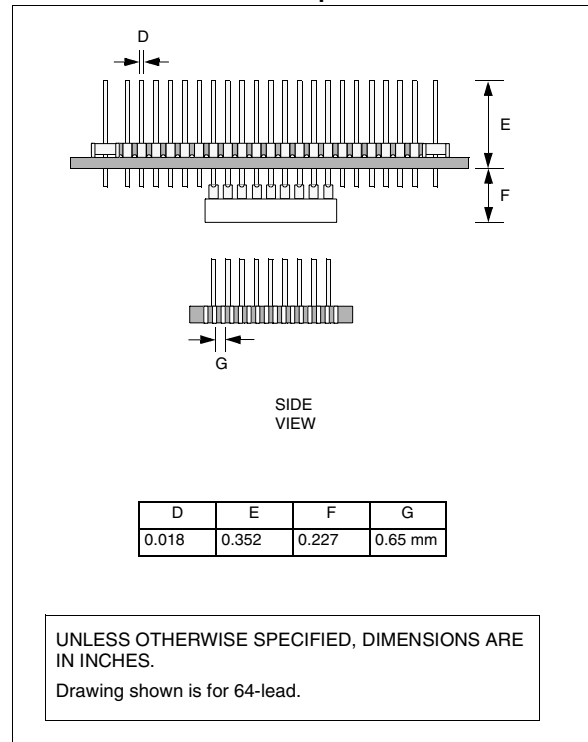

Transition Socket Specification

SOT/DFN/QFN TRANSITION SOCKETS

SOT/DFN/QFN transition sockets and associated hardware are shown below.

FIGURE 7: SOT TRANSITION SOCKET WITH CABLE

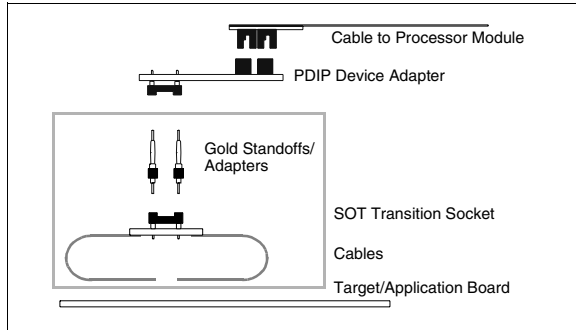

FIGURE 8: DFN/QFN TWO-PART TRANSITION SOCKET

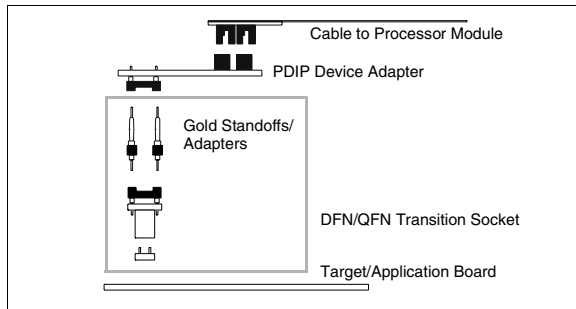

FIGURE 9: QFN TRANSITION SOCKET

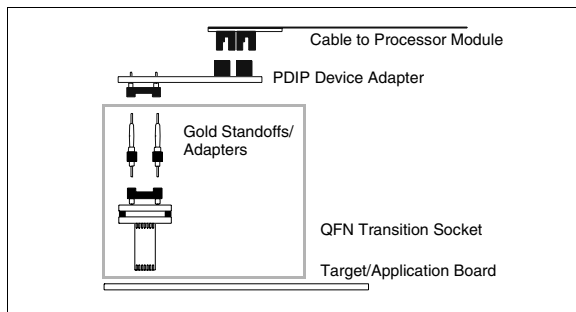

FIGURE 10: DFN TRANSITION SOCKET WITH CABLE

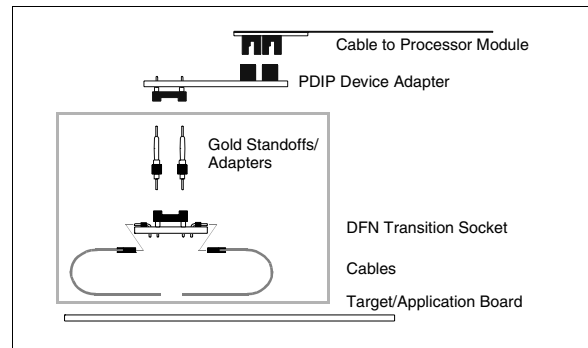
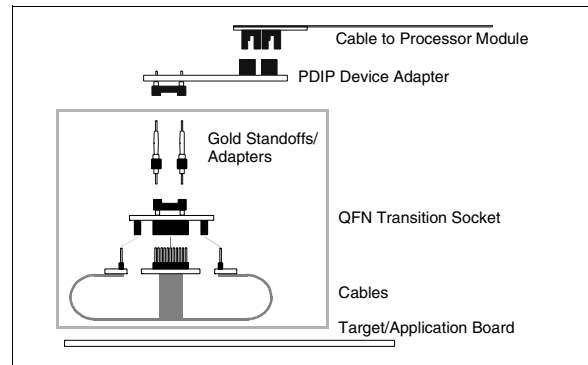

FIGURE 11: QFN TRANSITION SOCKET WITH CABLE



Microchip offers the following SOT/DFN/QFN transition sockets:

- XLT06SOT: One 6-lead SOT transition socket with cable
- XLT08DFN: One 8-lead DFN two-part transition socket
- XLT08DFN2: One 8-lead DFN transition socket with cable
- XLT16QFN1: One 16-lead QFN transition socket with cable
- XLT28QFN3: One 28-lead QFN transition socket with cable
- XLT28QFN4: One 28-lead QFN transition socket with cable
- XLT44QFN2: One 44-lead QFN transition socket with cable
- XLT44QFN3: One 44-lead QFN transition socket with cable

The following sockets have been discontinued:

- XLT28QFN: One 28-lead QFN transition socket. (Replaced by XLT28QFN4.)
- XLT28QFN2: One 28-lead QFN transition socket. (Replaced by XLT28QFN3.)
- XLT44QFN: One 44-lead QFN two-part transition socket. (Replaced by XLT44QFN2.)

See the drawings in this section for layout dimensions.

Transition Socket Specification

RECOMMENDED INSTALLATION OF TRANSITION SOCKETS WITH CABLES

For transition sockets that use a cable, follow these instructions for installing your transition socket on the target board.

PCB Layout Considerations:

Make sure you leave enough room on the PCB to accommodate the cable, i.e., space your target pads for each device far enough apart so that the cable from one pad group will not interfere with another pad group.

6-Pin SOT Solder Instructions:

1. Remove protective cable covering from end of cable.
2. Position cables on target board (see below.) Tape down to prevent movement.
3. Solder each lead to target pad.
4. Remove tape and clean.

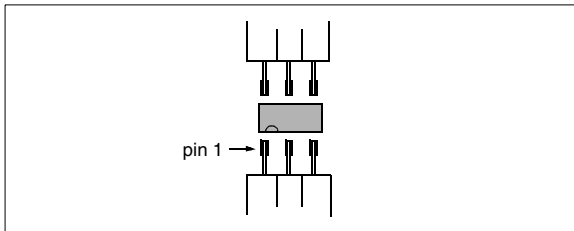

8-Pin DFN Solder Instructions:

1. Prepare leads by trimming narrowest portion to 0.10 inches maximum in length (see below.)
2. Position cables on target board (see below.) Tape down to prevent movement.
3. Solder each lead to target pad.
4. Remove tape and clean.

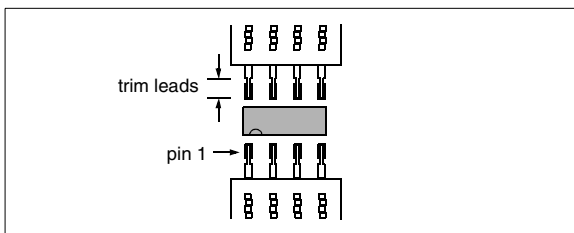

8-Pin DFN Assembly Instructions:

1. Start with cable associated with pin 1.
2. Fold cable up and over, forming a radius.
3. Mate with the header on the side of the transition socket assembly, making sure pin 1 mates with the pin labeled "DFN Pin 1".
4. Fold over and mate the other cable.

16-Pin QFN Solder Instructions:

1. Remove protective cable jacket from stripped end of cable.
2. Lay out the four cables in a "+" pattern (see below.)

3. Center each cable on the footprint (see below.) Tape down each cable to prevent movement.
4. Solder each lead to target pad.
5. Remove tape and clean

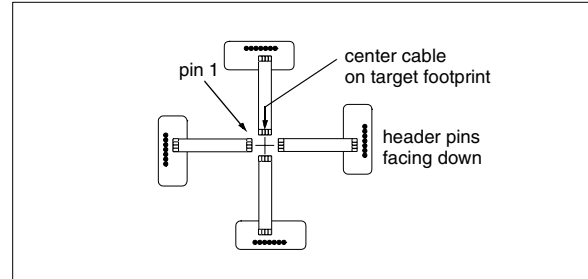

16-Pin QFN Assembly Instructions:

1. Start with cable associated with pin 1.
2. Fold cable up and over, forming a radius. Header pins will now be facing upwards.
3. Mate with the socket on the underside of the transition socket assembly, making sure pin 1 mates with the pin labeled "QFN Pin 1".
4. Fold over and mate the other cables.

28/44-Pin QFN Solder Instructions:

1. Remove protective cable jacket from stripped end of cable.
2. Lay out with long cables opposing each other and short cables opposing each other (see below.)
3. Place center lead (6th lead for 44-pin, 4th lead for 28-pin) on center target pad to center each cable on the footprint (see below.) Tape down each cable to prevent movement.
4. Solder each lead to target pad.
5. Remove tape and clean

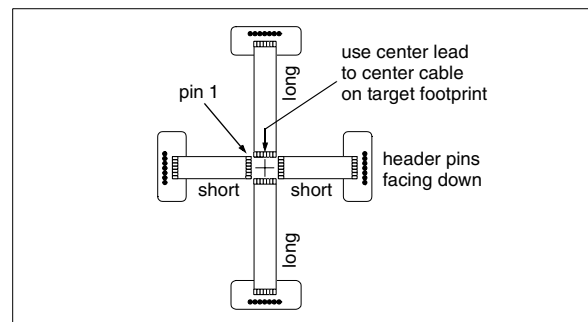

28/44-Pin QFN Assembly Instructions:

1. Start with cable associated with pin 1.
2. Fold cable up and over, forming a radius. Header pins will now be facing upwards.
3. Mate with the socket on the underside of the transition socket assembly, making sure pin 1 mates with the pin labeled "QFN Pin 1".
4. Fold over and mate the other cables.

Transition Socket Specification

RECOMMENDED PCB LAYOUT

The recommended target board footprint layout for different pin-counts is shown here.

FIGURE 12:6-PIN SOT, 8-PIN DFN

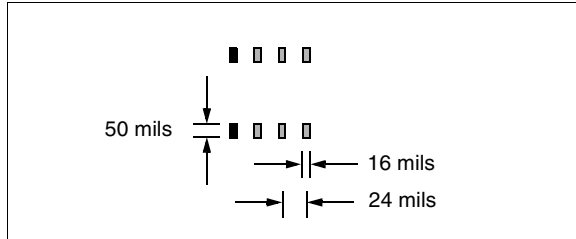

FIGURE 13:16-PIN QFN

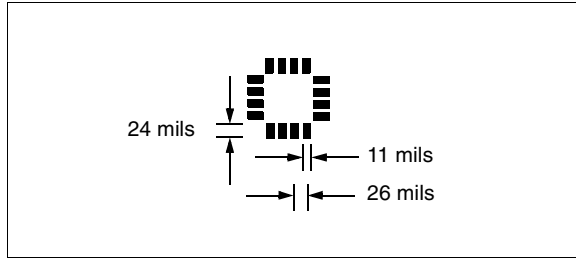

FIGURE 14:28-PIN QFN

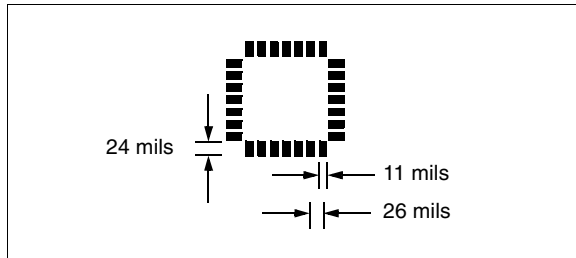
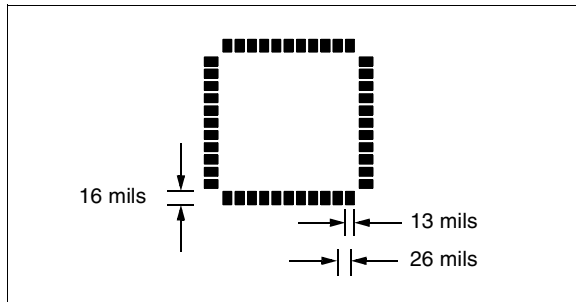
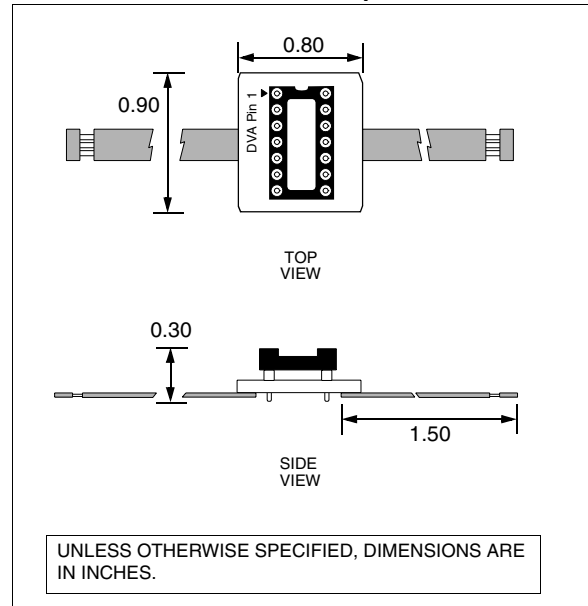

FIGURE 15:44-PIN QFN



XLT06SOT

6-lead SOT-23 to 0.80-inch Adapter Socket



XLT08DFN2

8/14-lead DIP to 0.025-inch Adapter Socket

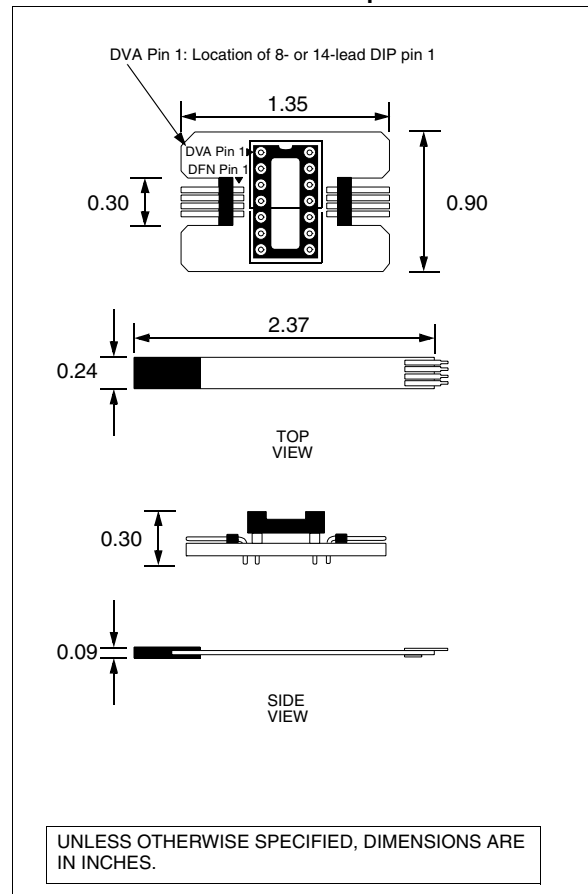

Transition Socket Specification

XLT16QFN1, XLT28QFN3, XLT28QFN4, XLT44QFN2, XLT44QFN3

Multi-lead DIP to 0.025-inch Adapter Socket Top

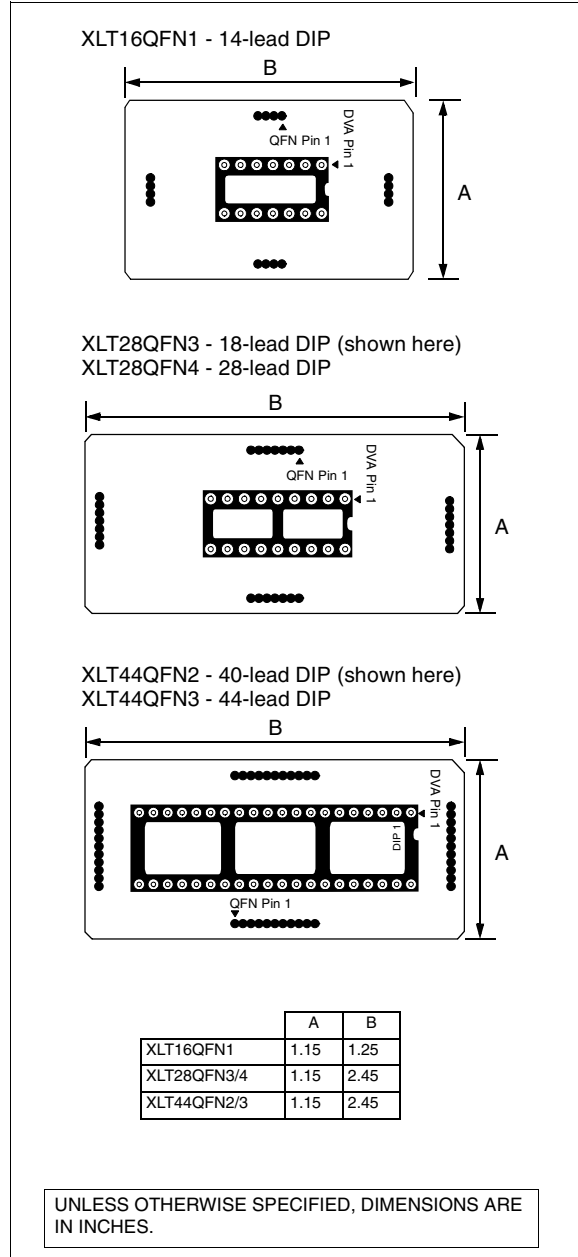

Multi-lead DIP to 0.025-inch Adapter Socket Side and Cables

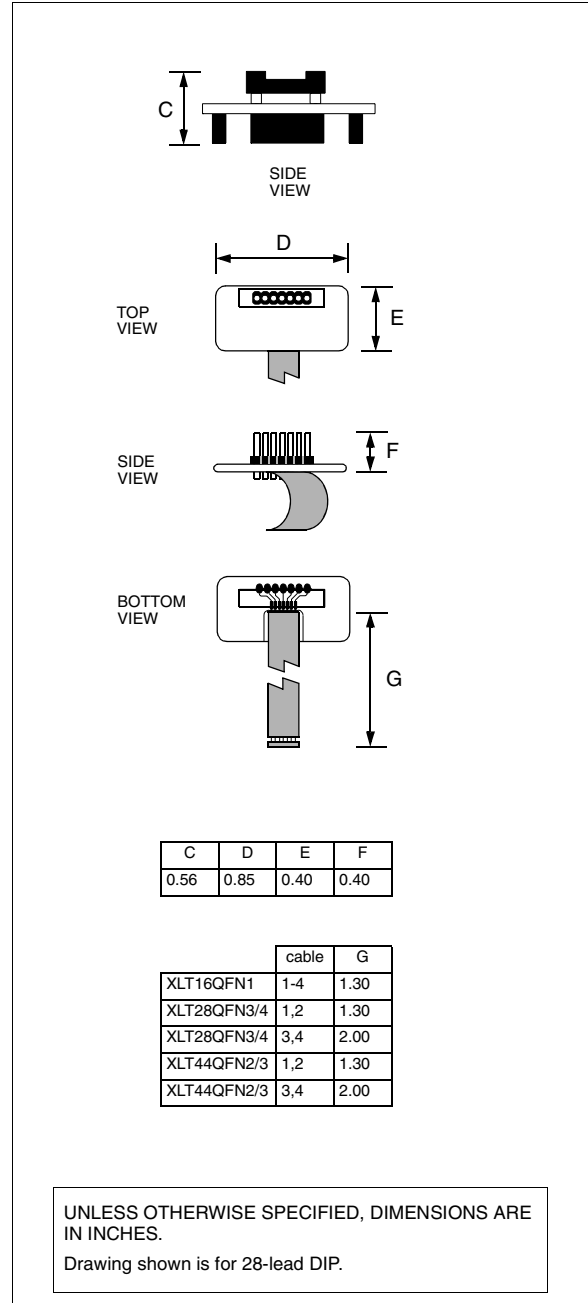

Transition Socket Specification

XLT08DFN (Discontinued - see XLT08DFN2)

8-lead DIP to 0.025-inch Adapter Socket

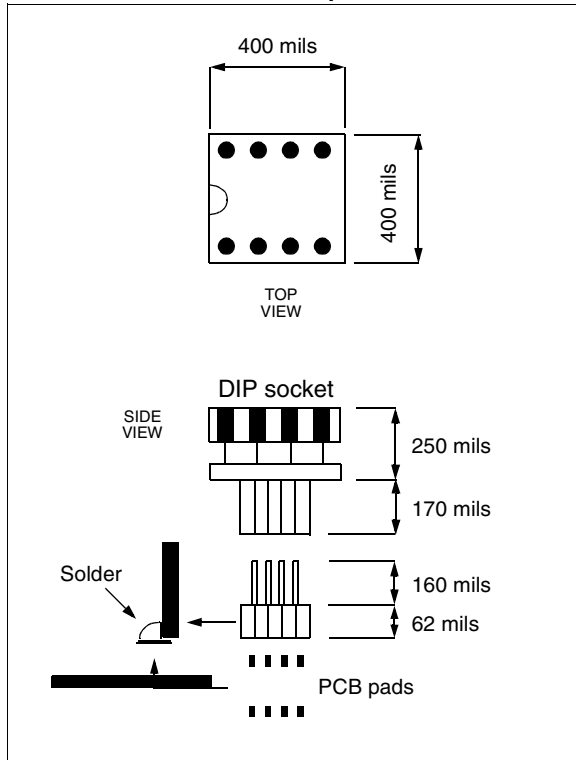

XLT28QFN (Discontinued - see XLT28QFN4)

28-lead DIP to 0.025-inch Adapter Socket

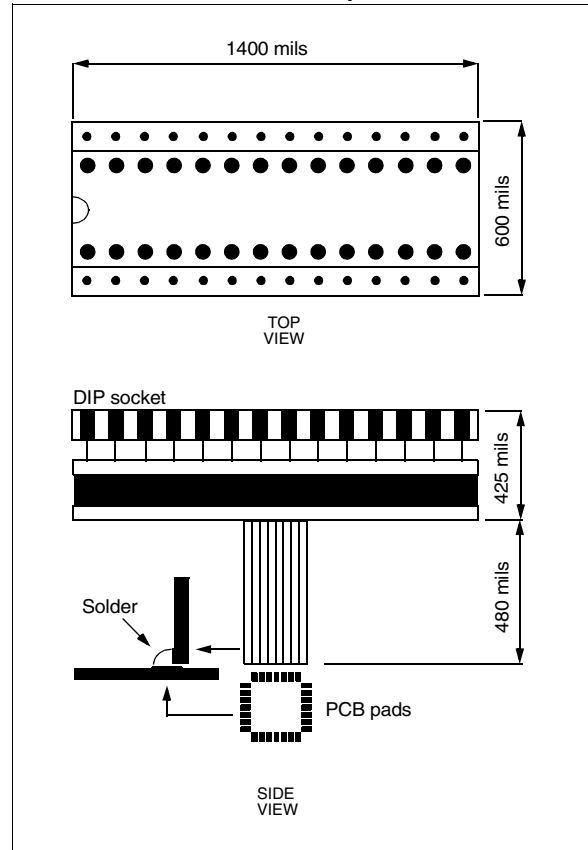

Transition Socket Specification

XLT28QFN (Discontinued - see XLT28QFN4)

28-lead DIP to 0.025-inch Adapter Socket

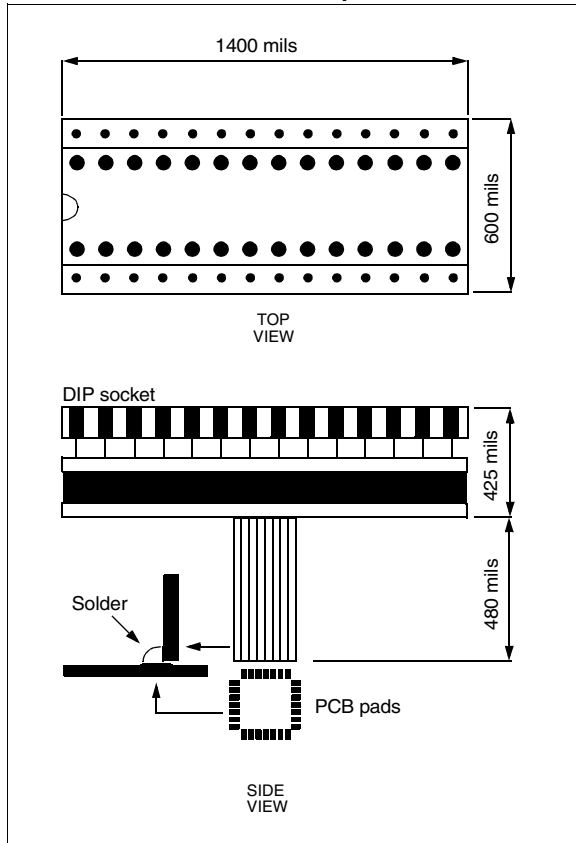

XLT28QFN2 (Discontinued - see XLT28QFN3)

18-lead DIP to 0.025-inch Adapter Socket

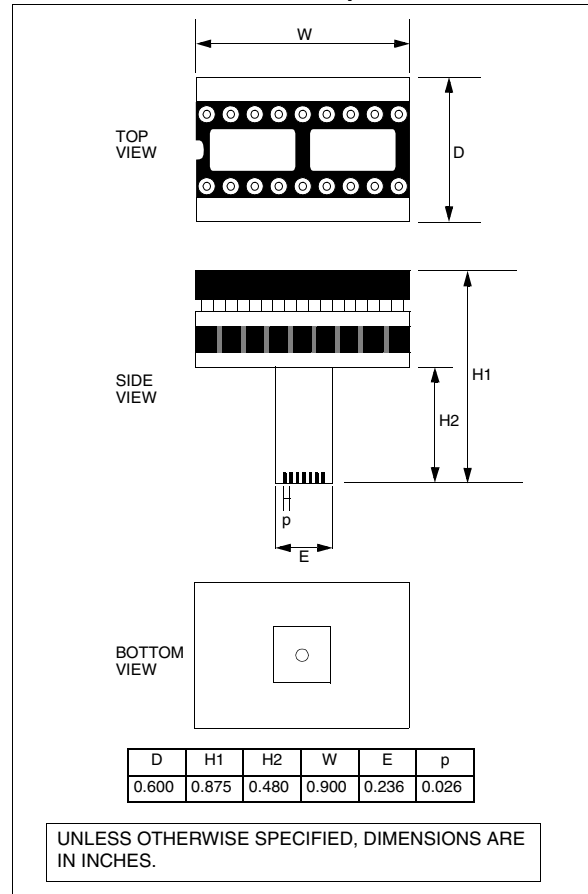

Transition Socket Specification

XLT44QFN (Discontinued - see XLT44QFN2)

40-lead DIP to 0.025-inch Adapter Socket

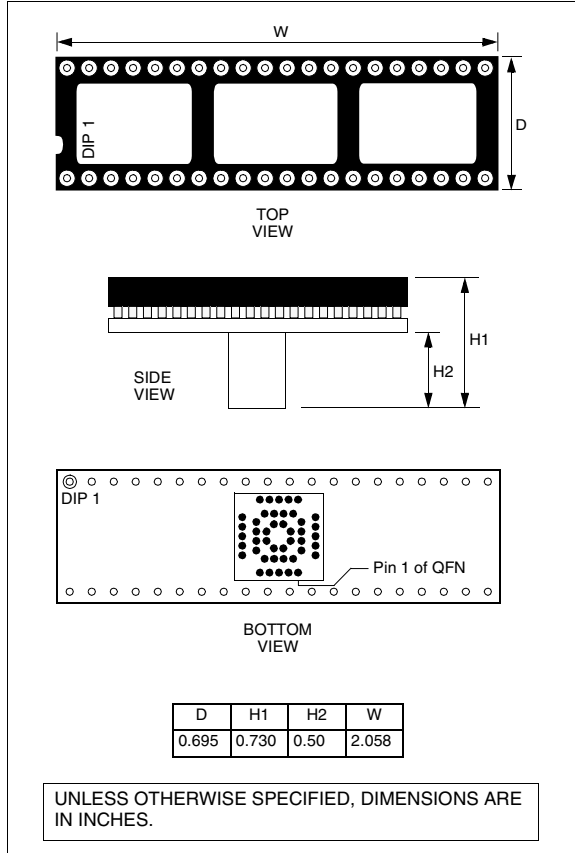

44-lead QFN Header

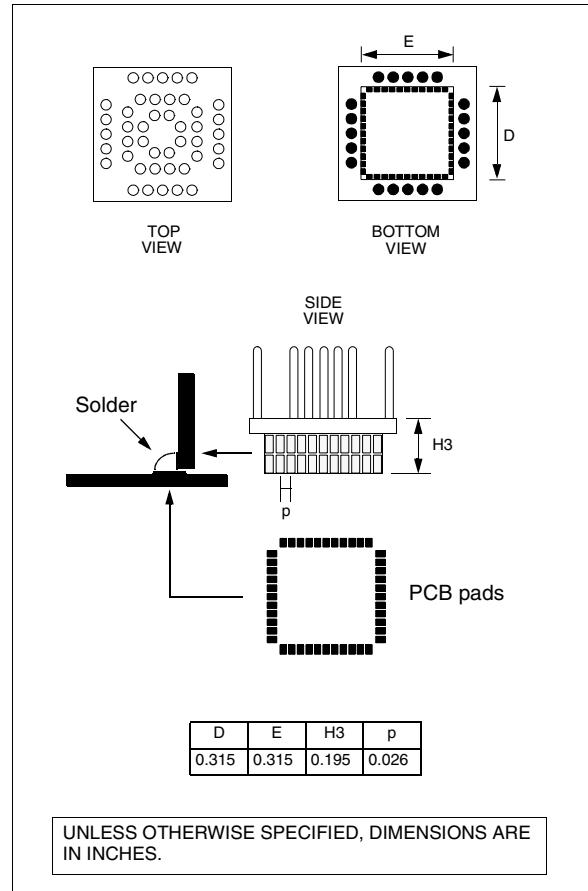

Transition Socket Specification

NOTES:



WORLDWIDE SALES AND SERVICE

AMERICAS

Corporate Office
2355 West Chandler Blvd.
Chandler, AZ 85224-6199
Tel: 480-792-7200
Fax: 480-792-7277
Technical Support:
<http://support.microchip.com>
Web Address:
www.microchip.com

Atlanta
Alpharetta, GA
Tel: 770-640-0034
Fax: 770-640-0307

Boston
Westborough, MA
Tel: 774-760-0087
Fax: 774-760-0088

Chicago
Itasca, IL
Tel: 630-285-0071
Fax: 630-285-0075

Dallas
Addison, TX
Tel: 972-818-7423
Fax: 972-818-2924

Detroit
Farmington Hills, MI
Tel: 248-538-2250
Fax: 248-538-2260

Kokomo
Kokomo, IN
Tel: 765-864-8360
Fax: 765-864-8387

Los Angeles
Mission Viejo, CA
Tel: 949-462-9523
Fax: 949-462-9608

San Jose
Mountain View, CA
Tel: 650-215-1444
Fax: 650-961-0286

Toronto
Mississauga, Ontario,
Canada
Tel: 905-673-0699
Fax: 905-673-6509

ASIA/PACIFIC

Australia - Sydney
Tel: 61-2-9868-6733
Fax: 61-2-9868-6755

China - Beijing
Tel: 86-10-8528-2100
Fax: 86-10-8528-2104

China - Chengdu
Tel: 86-28-8676-6200
Fax: 86-28-8676-6599

China - Fuzhou
Tel: 86-591-8750-3506
Fax: 86-591-8750-3521

China - Hong Kong SAR
Tel: 852-2401-1200
Fax: 852-2401-3431

China - Shanghai
Tel: 86-21-5407-5533
Fax: 86-21-5407-5066

China - Shenyang
Tel: 86-24-2334-2829
Fax: 86-24-2334-2393

China - Shenzhen
Tel: 86-755-8203-2660
Fax: 86-755-8203-1760

China - Shunde
Tel: 86-757-2839-5507
Fax: 86-757-2839-5571

China - Qingdao
Tel: 86-532-502-7355
Fax: 86-532-502-7205

ASIA/PACIFIC

India - Bangalore
Tel: 91-80-2229-0061
Fax: 91-80-2229-0062

India - New Delhi
Tel: 91-11-5160-8631
Fax: 91-11-5160-8632

Japan - Kanagawa
Tel: 81-45-471- 6166
Fax: 81-45-471-6122

Korea - Seoul
Tel: 82-2-554-7200
Fax: 82-2-558-5932 or
82-2-558-5934

Malaysia - Penang
Tel: 011-604-646-8870
Fax: 011-604-646-5086

Philippines - Manila
Tel: 011-632-634-9065
Fax: 011-632-634-9069

Singapore
Tel: 65-6334-8870
Fax: 65-6334-8850

Taiwan - Kaohsiung
Tel: 886-7-536-4818
Fax: 886-7-536-4803

Taiwan - Taipei
Tel: 886-2-2500-6610
Fax: 886-2-2508-0102

Taiwan - Hsinchu
Tel: 886-3-572-9526
Fax: 886-3-572-6459

EUROPE

Austria - Weis
Tel: 43-7242-2244-399
Fax: 43-7242-2244-393

Denmark - Ballerup
Tel: 45-4450-2828
Fax: 45-4485-2829

France - Massy
Tel: 33-1-69-53-63-20
Fax: 33-1-69-30-90-79

Germany - Ismaning
Tel: 49-89-627-144-0
Fax: 49-89-627-144-44

Italy - Milan
Tel: 39-0331-742611
Fax: 39-0331-466781

Netherlands - Drunen
Tel: 31-416-690399
Fax: 31-416-690340

England - Berkshire
Tel: 44-118-921-5869
Fax: 44-118-921-5820