

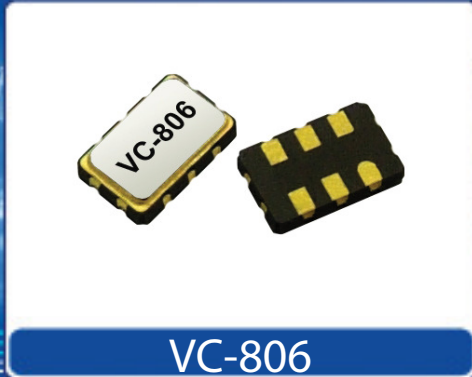

Helping Customers Innovate, Improve & Grow

VC-806

Description

Vectron's VC-806 Crystal Oscillator is a quartz stabilized, differential output oscillator, operating off either a 2.5 or 3.3 volt supply in a hermetically sealed 3.2x5 ceramic package.

Features

- Ultra Low Jitter Performance, Fundamental or 3rd OT Crystal Design
- Output Frequencies to 250.000MHz
- <0.7 ps RMS jitter, 12kHz-20MHz
- Differential Output
- Enable/Disable
- -10/70°C or -40/85°C Operation
- Hermetically Sealed 3.2x5 Ceramic Package
- Product is compliant to RoHS directive  and fully compatible with lead free assembly

Applications

- Storage Area Networking
- Telecom
- Ethernet, GE, SynchE
- Fiber Channel
- PON
- Driving A/D's, D/A's, FPGA's
- Test and Measurement
- Medical
- COTS

Block Diagram

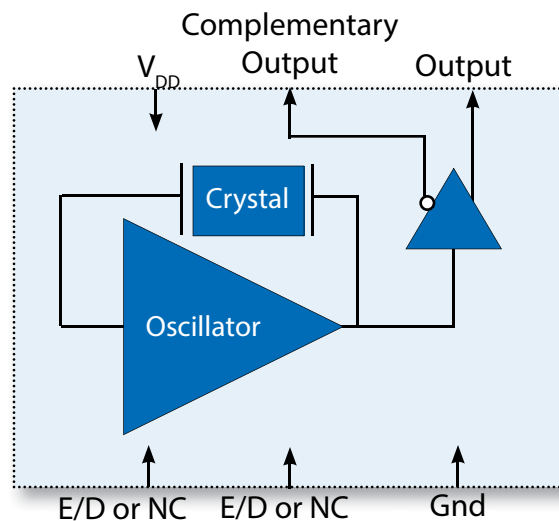

Performance Specifications

Table 1. Electrical Performance, LVPECL Option

Parameter	Symbol	Min	Typ	Max	Units
Supply					
Voltage ¹	V_{DD}	3.135 2.375	3.3 2.5	3.465 2.625	V
Current (No Load)	I_{DD}		50	75	mA
Frequency					
Nominal Frequency ²	f_N	25		250.000	MHz
Stability ^{2,3} (Ordering Option)		±25, ±50, ±100			ppm
Outputs					
Output Logic Levels ⁴ , -10/70°C Output Logic High Output Logic Low	V_{OH} V_{OL}	$V_{DD}-1.025$ $V_{DD}-1.810$		$V_{DD}-0.880$ $V_{DD}-1.620$	V
Output Logic Levels ⁴ , -40/85°C Output Logic High Output Logic Low	V_{OH} V_{OL}	$V_{DD}-1.085$ $V_{DD}-1.830$		$V_{DD}-0.880$ $V_{DD}-1.555$	V
Output Rise and Fall Time ⁴ Rise Time Fall Time	t_R t_F			600 600	ps ps
Load		50 ohms into $V_{DD}-2.0V$			
Duty Cycle ⁵		45	50	55	%
Jitter (12 kHz - 20 MHz BW) ⁶	ϕ_J		0.3	0.7	ps
Period Jitter ⁷ RMS P/P	ϕ_J		2.6 23		ps ps
Random Jitter Deterministic Jitter	R_J D_J		2.6 <0.2		ps ps
Enable/Disable					
Output Enabled ⁸ Output Disabled	V_{IH} V_{IL}	$0.7*V_{DD}$		$0.3*V_{DD}$	V V
Enable/Disable Time	t_D			200	ns
Enable/Disable Leakage Current				±200	uA
Enable Pull-Up Resistor Output Enabled Output Disabled			33 1		KOhm MOhm
Start-Up Time	t_{SU}			10	ms
Operating Temp. (Ordering Option)	T_{OP}	-10/70 or -40/85			°C
Package Size		3.2x5.0x1.3			mm

1. The VC-806 power supply pin should be filtered, eg, a 0.1 and 0.01uf capacitor.
2. See Standard Frequencies and Ordering Information for more information.
3. Includes calibration tolerance, operating temperature, supply voltage variations, aging and IR reflow.
4. Figure 2 defines these parameters and Figure 1 defines the test circuit.
5. Duty Cycle is defines as the On/Time Period.
6. Measured using an Agilent E5052, 156.25MHz.
7. Measured using a Wavecrest SIA3300C, 90K samples.
8. Outputs will be Enabled if Enable/Disable is left open.

Performance Specifications

Table 2. Electrical Performance, LVDS Option					
Parameter	Symbol	Min	Typ	Max	Units
Supply					
Voltage ¹	V_{DD}	3.135 2.375	3.3 2.5	3.465 2.625	V
Current (No Load)	I_{DD}			60	mA
Frequency					
Nominal Frequency ²	f_N	80		250.000	MHz
Stability ^{2,3} (Ordering Option)		$\pm 25, \pm 50, \pm 100$			ppm
Outputs					
Output Logic Levels ⁴ Output Logic High Output Logic Low	V_{OH} V_{OL}	0.9	1.43 1.10	1.6	V
Output Swing		247	330	454	mV
Differential Output Swing		494	660	908	mV
Differential Output Error				50	mV
Offset Voltage		1.125	1.25	1.375	V
Offset Voltage Error				50	mV
Output Leakage Current				10	uA
Output Rise and Fall Time ⁴ Rise Time Fall Time	t_R / t_F			600 600	ps ps
Load		100 ohms differential			
Duty Cycle ⁵		45	50	55	%
Jitter (12 kHz - 20 MHz BW) ⁶	ϕJ		0.35	0.8	ps
Period Jitter ⁷ RMS P/P	ϕJ		2.9 25.1		ps ps
Random Jitter	R_J		2.9		ps
Deterministic Jitter	D_J		<0.2		ps
Enable/Disable					
Output Enabled ⁸ Output Disabled	V_{IH} V_{IL}	$0.7 * V_{DD}$		$0.3 * V_{DD}$	V V
Enable/Disable Time	t_D			200	ns
Enable/Disable Leakage Current				± 200	uA
Enable Pull-Up Resistor Output Enabled Output Disabled			33 1		KOhm MOhm
Start-Up Time	t_{SU}			10	ms
Operating Temp. (Ordering Option)	T_{OP}	-10/70 or -40/85			°C
Package Size		3.2x5.0x1.3			mm

1. The VC-806 power supply pin should be filtered, eg, a 0.1 and 0.01 uF capacitor.
2. See Standard Frequencies and Ordering Information for more information.
3. Includes calibration tolerance, operating temperature, supply voltage variations, aging and IR reflow.
4. Figure 2 defines these parameters and Figure 3 defines the test circuit.
5. Duty Cycle is defined as the On/Time Period.
6. Measured using an Agilent E5052, 156.250MHz.
7. Measured using a Wavecrest SIA3300C, 90K samples.
8. Outputs will be Enabled if Enable/Disable is left open.

Test Diagrams

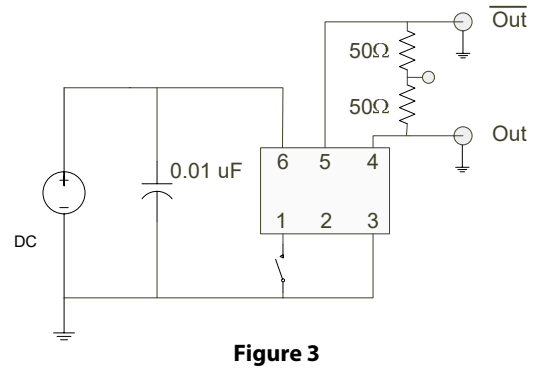
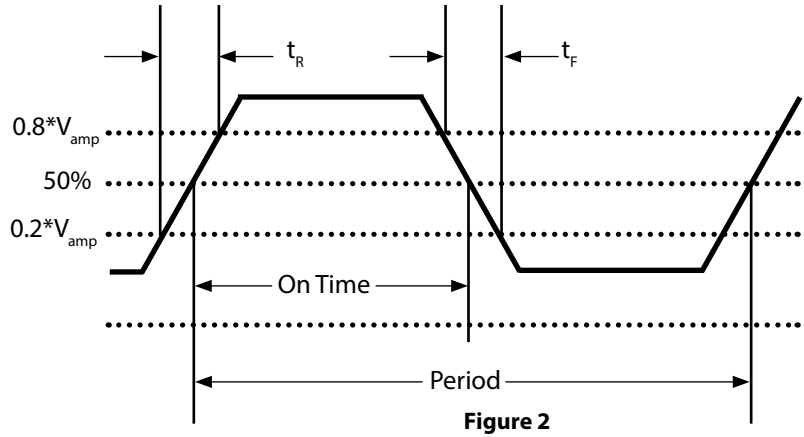
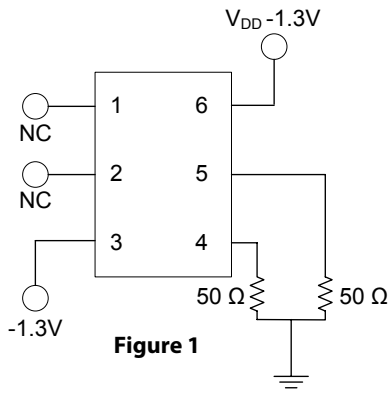

Package and Pinout

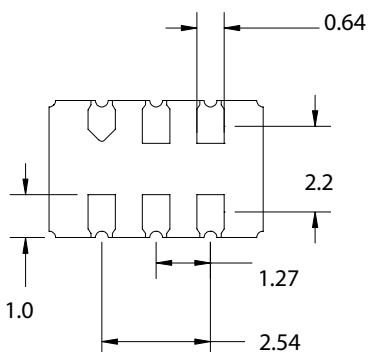
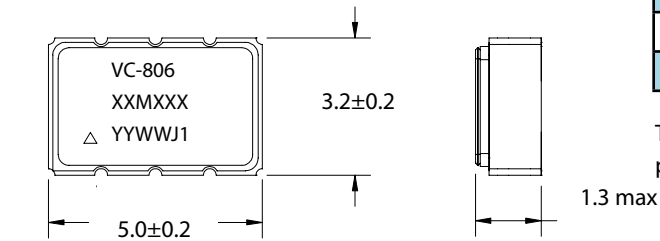

Figure 3 Package Dimensions in mm

Table 3. Pinout

Pin #	Symbol	Function
1	E/D or NC	Enable Disable or No Connection
2	E/D or NC	Enable Disable or No Connection
3	GND	Electrical and Lid Ground
4	f_o	Output Frequency
5	Cf_o	Complementary Output Frequency
6	V_{DD}	Supply Voltage

The Enable/Disable function is set at the factory on either pin 1 or pin 2 and is an ordering option.

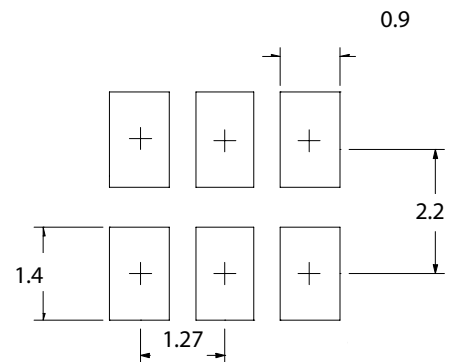

Figure 4 Pad Layout Dimensions in mm

LVPECL Application Diagrams

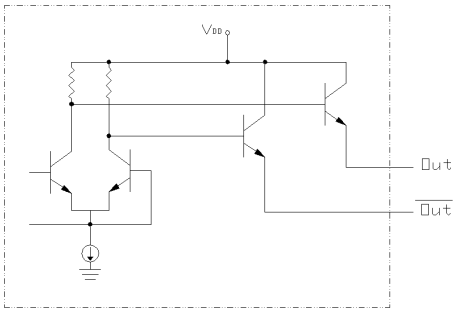

Figure 5 Standard PECL Output Configuration

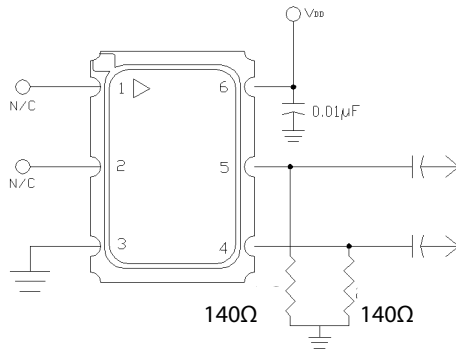

Figure 6 Single Resistor Termination Scheme

Resistor values are typically 140 ohms for 3.3V operation.

Resistor values are typically 84 for 2.5V operation.

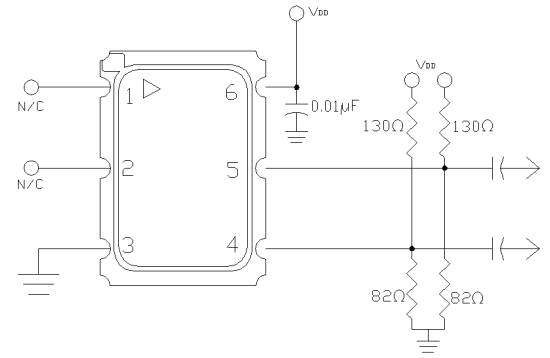

Figure 7 Pull-Up Pull Down Termination

Resistor values are typically for 3.3V operation. For 2.5V operation, the resistor to ground is 62 ohms and the resistor to supply is 240 ohms.

The VC-806 incorporates a standard PECL output scheme, which are un-terminated emitters as shown in Figure 5. There are numerous application notes on terminating and interfacing PECL logic and the two most common methods are a single resistor to ground, Figure 6, and a pull-up/pull-down scheme as shown in Figure 7. An AC coupling capacitor is optional, depending on the application and the input logic requirements of the next stage.

LVDS Application Diagrams

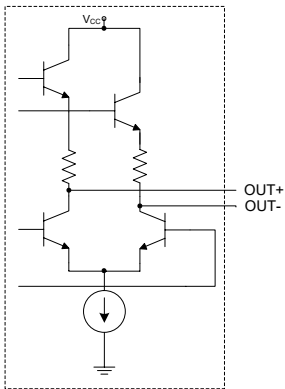

Figure 8 Standard LVDS Output Configuration

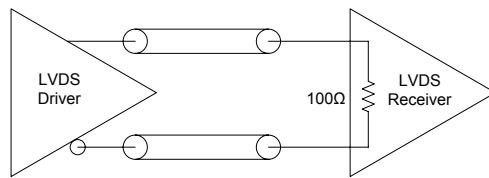

Figure 9 LVDS to LVDS Connection, Internal 100ohm

Some LVDS structures have an internal 100 ohm resistor on the input and do not need additional components.

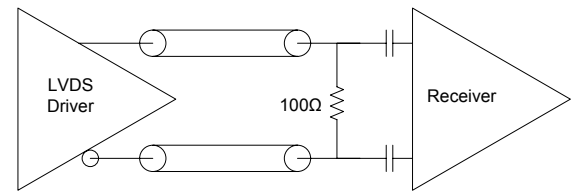

Figure 10 LVDS to LVDS Connection External 100ohm and AC blocking caps

Some input structures may not have an internal 100 ohm resistor on the input and will need an external 100ohm resistor for impedance matching. Also, the input may have an internal DC bias which may not be compatible with LVDS levels, AC blocking capacitors can be used.

One of the most important considerations is terminating the Output and Complementary Outputs equally. An unused output should not be left un-terminated, and if one of the two outputs is left open it will result in excessive jitter on both. PC board layout must take this and 50 ohm impedance matching into account. Load matching and power supply noise are the main contributors to jitter related problems.

Environmental and IR Compliance

Table 4. Environmental Compliance	
Parameter	Condition
Mechanical Shock	MIL-STD-883 Method 2002
Mechanical Vibration	MIL-STD-883 Method 2007
Temperature Cycle	MIL-STD-883 Method 1010
Solderability	MIL-STD-883 Method 2003
Fine and Gross Leak	MIL-STD-883 Method 1014
Resistance to Solvents	MIL-STD-883 Method 2015
Moisture Sensitivity Level	MSL1
Contact Pads	Gold over Nickel

Suggested IR Profile

Devices are built using lead free epoxy and can be subjected to standard lead free IR reflow conditions shown in Table 5. Contact pads are gold over nickel and lower maximum temperatures can also be used, such as 220C.

Parameter	Symbol	Value
PreHeat Time	t_s	200 sec Max
Ramp Up	R_{UP}	3°C/sec Max
Time above 217°C	t_L	150 sec Max
Time to Peak Temperature	t_{AMB-P}	480 sec Max
Time at 260°C	t_P	30 sec Max
Time at 240°C	t_{P2}	60 sec Max
Ramp down	R_{DN}	6°C/sec Max

Solderprofile:

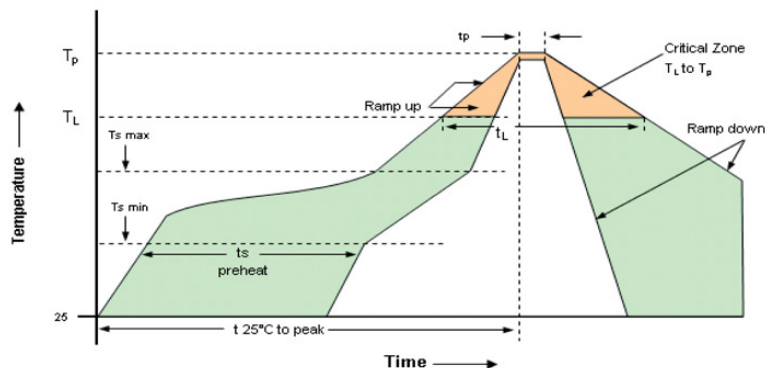

Maximum Ratings, Tape & Reel

Absolute Maximum Ratings and Handling Precautions

Stresses in excess of the absolute maximum ratings can permanently damage the device. Functional operation is not implied or any other excess of conditions represented in the operational sections of this data sheet. Exposure to absolute maximum ratings for extended periods may adversely affect device reliability.

Although ESD protection circuitry has been designed into the VC-806, proper precautions should be taken when handling and mounting, VI employs a Human Body Model and Charged Device Model for ESD susceptibility testing and design evaluation.

ESD thresholds are dependent on the circuit parameters used to define the model. Although no industry standard has been adopted for the CDM a standard resistance of 1.5kOhms and capacitance of 100pF is widely used and therefor can be used for comparison purposes.

Parameter	Symbol	Rating	Unit
Storage Temperature	T_{STORE}	-55/125	°C
Supply Voltage	V_{DD}	-0.5 to 5.0	V
Enable Disable Voltage	E/D	-0.5 to $V_{DD}+0.5$	V
ESD, Human Body Model		1500	V
ESD, Charged Device Model		1000	V

Table 7. Tape and Reel Information

Tape Dimensions (mm)					Reel Dimensions (mm)							
W	F	Do	Po	P1	A	B	C	D	N	W1	W2	#/Reel
16	7.5	1.5	4	8	180	2	13	21	60	17	21	250

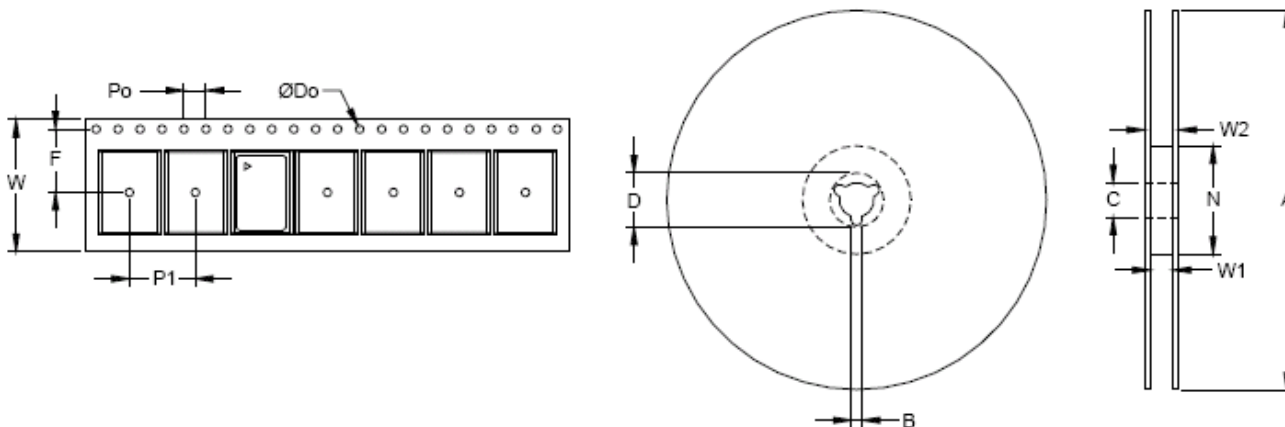
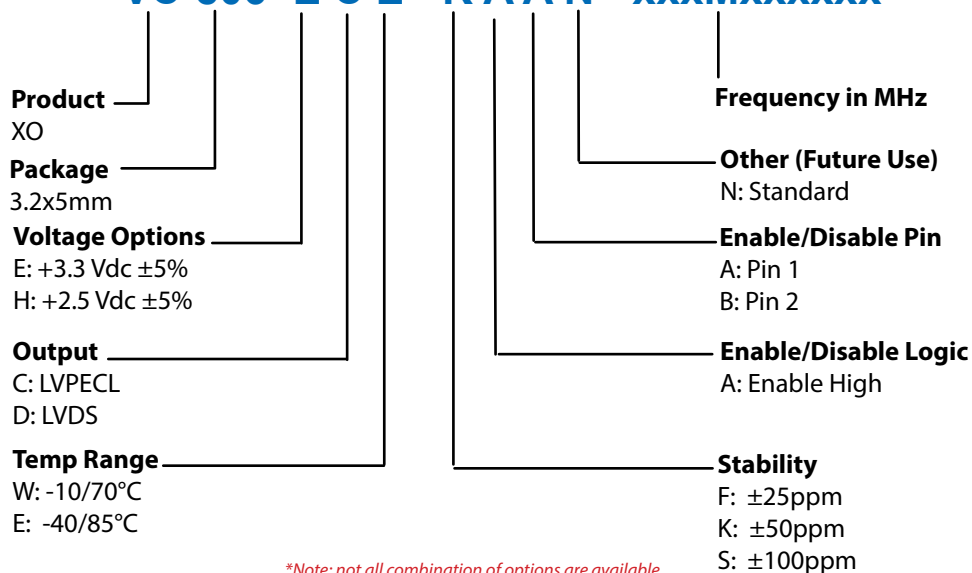

Table 8. Standard Frequencies (MHz)

25.000	27.000	32.000	33.000	38.880	40.000	50.000	53.125	56.000	56.250	60.000	61.440
62.500	66.000	66.667	67.500	75.000	77.760	80.000	83.333	98.304	100.000	106.250	108.000
114.285	122.880	124.512	125.000	133.000	143.000	148.500	150.000	153.600	155.520	1562.50	156.253906
160.000	161.130	164.355	166.6286	166.6667	167.000	167.330	168.750	173.3707	180.000	186.667	187.500
190.000	200.000	212.500	218.750	250.000							

Ordering Information

VC-806- E C E - K A A N - xxxMxxxxxx



*Note: not all combination of options are available.
Other specifications may be available upon request.

Example: VC-806-ECE-KAAN-155M520000

*** Add SNPBDIP for tin lead solder dip**

Example: VC-806-ECE-KAAN-155M520000_SNPBDIP

Revision History

Revision Date	Approved	Description
Aug 10, 2018	FB	Update logo and contact information, added SNPBDIP ordering option



Microsemi Headquarters
One Enterprise, Aliso Viejo, CA 92656 USA
Within the USA: +1 (800) 713-4113
Outside the USA: +1 (949) 380-6100
Sales: +1 (949) 380-6136
Fax: +1 (949) 215-4996
email: sales.support@microsemi.com
www.microsemi.com

Microsemi, a wholly owned subsidiary of Microchip Technology Inc. (Nasdaq: MCHP), offers a comprehensive portfolio of semiconductor and system solutions for aerospace & defense, communications, data center and industrial markets. Products include high-performance and radiation-hardened analog mixed-signal integrated circuits, FPGAs, SoCs and ASICs; power management products; timing and synchronization devices and precise time solutions, setting the world's standard for time; voice processing devices; RF solutions; discrete components; enterprise storage and communication solutions, security technologies and scalable anti-tamper products; Ethernet solutions; Power-over-Ethernet ICs and midspans; as well as custom design capabilities and services. Learn more at www.microsemi.com.

Microsemi makes no warranty, representation, or guarantee regarding the information contained herein or the suitability of its products and services for any particular purpose, nor does Microsemi assume any liability whatsoever arising out of the application or use of any product or circuit. The products sold hereunder and any other products sold by Microsemi have been subject to limited testing and should not be used in conjunction with mission-critical equipment or applications. Any performance specifications are believed to be reliable but are not verified, and Buyer must conduct and complete all performance and other testing of the products, alone and together with, or installed in, any end-products. Buyer shall not rely on any data and performance specifications or parameters provided by Microsemi. It is the Buyer's responsibility to independently determine suitability of any products and to test and verify the same. The information provided by Microsemi hereunder is provided "as is, where is" and with all faults, and the entire risk associated with such information is entirely with the Buyer. Microsemi does not grant, explicitly or implicitly, to any party any patent rights, licenses, or any other IP rights, whether with regard to such information itself or anything described by such information. Information provided in this document is proprietary to Microsemi, and Microsemi reserves the right to make any changes to the information in this document or to any products and services at any time without notice.

©2018 Microsemi, a wholly owned subsidiary of Microchip Technology Inc. All rights reserved. Microsemi and the Microsemi logo are registered trademarks of Microsemi Corporation. All other trademarks and service marks are the property of their respective owners.