

Helping Customers Innovate, Improve & Grow

VT-704

Description

Vectron's VT-704 Temperature Compensated Crystal Oscillator (TCXO) is a quartz stabilized, Clipped sine wave or CMOS output, analog temperature compensated oscillator, operating off a 2.5V to 3.3 volt supply in a hermetically sealed 7.0 x 5.0 mm ceramic package.

Features

- Clipped Sine Wave or CMOS Output
- 5.000 - 52.000MHz Output Frequency
- ± 0.5 ppm Temperature Stability
- Optional Frequency Tuning
- Fundamental Crystal Design
- Gold over nickel contact pads
- Hermetically Sealed Ceramic SMD package
- Product is compliant to RoHS directive  and fully compatible with lead free assembly

Applications

- Femto Cells
- Base Stations
- IP Networking
- Global Positioning Systems
- Point to Point Radio
- Manpack Radio
- Test and Measurement

Block Diagram

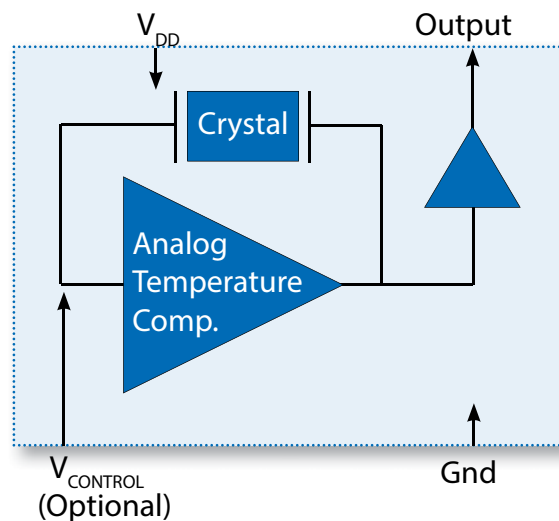

Specifications

Table 1. Electrical Performance, Clipped Sine Wave Option

Parameter	Symbol	Min.	Typ	Max	Units
Output Frequency ¹ , <i>Ordering Option</i>	f_o	5		52	MHz
Supply Voltage ³ , <i>Ordering Option</i>	V_{DD}	+2.5, +2.8, +3.0, +3.3			V
Supply Current	I_{DD}			3.5	mA
Operating Temperature, <i>Ordering Option</i>	T_{OP}	0/55, -10/70, -20/70, -30/80, -30/85, -40/85			°C
Frequency Stability					
Stability Over T_{OP} ⁴ , <i>Ordering Option</i>	F_{STAB}	±0.5, ±1.0, ±1.5, ±2.0, ±2.5, ±3.0, ±4.0, ±5.0			ppm
Frequency Tolerance ⁵	F_{TOL}			±2.0	ppm
Power Supply Stability, ±5%	F_{PWR}			±0.1	ppm
Load Stability, ±10%	F_{LOAD}			±0.2	ppm
Aging / 1st year	F_{AGE}			±1.0	ppm
Frequency Tuning (EFC), <i>Ordering Option</i>					
Tuning Range ⁶	PR	±5.0, ±8.0, ±10.0, ±12.0			ppm
Tuning Slope		Positive			
Control Voltage to reach Pull Range	V_C	0.5	1.5	2.5	V
Control Voltage Impedance		100			Kohm
RF Output (Clipped Sine Wave), <i>Ordering Option</i>					
Output Level High	V_o p-p	0.8			V
Output Load	C_L		10k 10pF		
Start Up Time	t_{SU}			2	ms
Phase Noise⁷					
Phase Noise, 10.00MHz ⁷	θ_N				dBc/Hz
10Hz			-96		
100Hz			-122		
1kHz			-140		
10kHz			-148		
100kHz			-153		

1. Refer to Table 8 for Standard Frequencies. Other Frequencies are available on request. Check with factory.
2. Output DC-cut capacitor is optional.
3. The VT-704 power supply pin (Pin4) should be filtered using a by-pass capacitor of 0.1uF for optimal performance.
4. Referenced to the midpoint between minimum and maximum frequency value over Operating Temperature Range.
5. Frequency measured at 25 °C, 1 hour after 2 IR reflows.
6. Referenced to Mid Control Voltage
7. Measured at ambient temperature using Agilent E5052B Signal Source Analyzer.

Table 2. Electrical Performance, CMOS Option					
Parameter	Symbol	Min.	Typ	Max	Units
Output Frequency ¹ , <i>Ordering Option</i>	f_o	5		52	MHz
Supply Voltage ³ , <i>Ordering Option</i>	V_{DD}	+2.5, +2.8, +3.0, +3.3			V
Supply Current	I_{DD}			6.0	mA
Operating Temperature, <i>Ordering Option</i>	T_{OP}	0/55, -10/70, -20/70, -30/80, -30/85, -40/85			°C
Frequency Stability					
Stability Over T_{op} ⁴ , <i>Ordering Option</i>	F_{STAB}	$\pm 0.5, \pm 1.0, \pm 1.5, \pm 2.0, \pm 2.5, \pm 3.0, \pm 4.0, \pm 5.0$			ppm
Frequency Tolerance ⁵	F_{TOL}			± 2.0	ppm
Power Supply Stability, $\pm 5\%$	F_{PWR}			± 0.1	ppm
Load Stability, $\pm 10\%$	F_{LOAD}			± 0.2	ppm
Aging / 1st year	F_{AGE}			± 1.0	ppm
Frequency Tuning (EFC), <i>Ordering Option</i>					
Tuning Range ⁶	PR	$\pm 5.0, \pm 8.0, \pm 10.0, \pm 12.0$			ppm
Tuning Slope		Positive			
Control Voltage to reach Pull Range	V_C	0.5	1.5	2.5	V
Control Voltage Impedance		100			Kohm
RF Output (CMOS), <i>Ordering Option</i>					
Output Level High Output Level Low	V_{OH} V_{OL}	$0.9 * V_{DD}$		$0.1 * V_{DD}$	V
Output Load	C_L			15	pF
Duty Cycle		45		55	%
Start Up Time	t_{SU}			2	ms
Rise & Fall Times				4	ns
Phase Noise ⁷					
Phase Noise, 10.00MHz ⁷ 10Hz 100Hz 1kHz 10kHz 100kHz	θ_N		-98 -129 -145 -153 -156		dBc/Hz

1. Refer to Table 8 for Standard Frequencies. Other Frequencies are available on request. Check with factory.
2. Output DC-cut capacitor is optional.
3. The VT-704 power supply pin (Pin4) should be filtered using a by-pass capacitor of 0.1uF for optimal performance.
4. Referenced to the midpoint between minimum and maximum frequency value over Operating Temperature Range.
5. Frequency measured at 25 °C, 1 hour after 2 IR reflows.
6. Referenced to Mid Control Voltage.
7. Measured at ambient temperature using Agilent E5052B Signal Source Analyzer

Phase Noise Performance for 10MHz Clipped Sine Wave

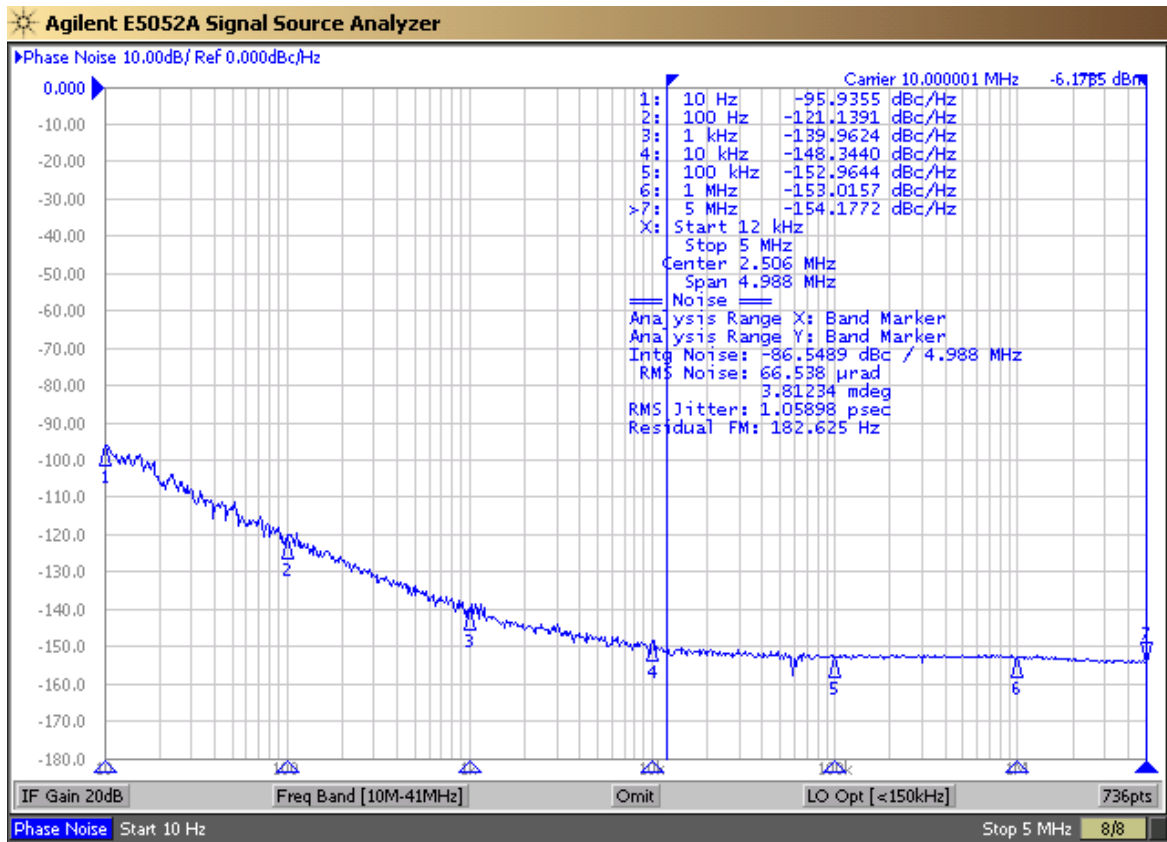

Phase Noise Performance for 10MHz CMOS

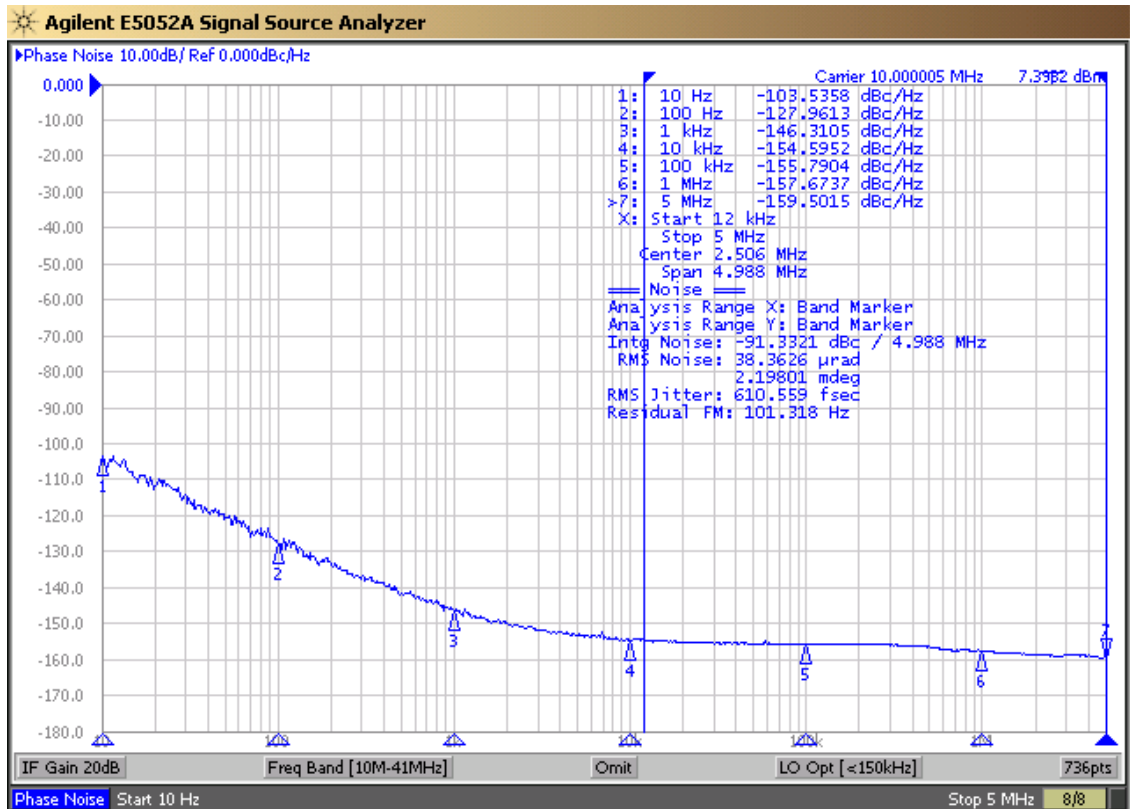

Package Outline Drawing & Pad Layout

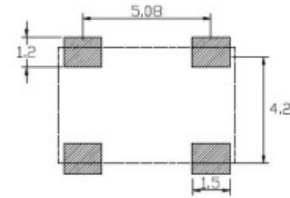
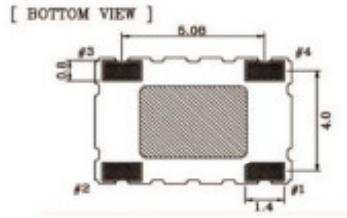
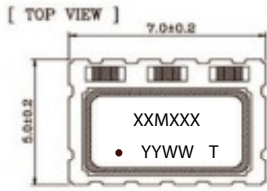

Dimensions in mm

Marking Information

XXMXX - Frequency (Example: 10M000)

YY - Year of Manufacture

WW - Week of the Year

T - Manufacturing Location

• - Pin 1 Indicator

Table 3. Pinout

Pin #	Symbol	Function
1	V _c or NC	TCXO Control Voltage or No Connect
2	GND	Ground
3	OUT	RF Output
4	V _{DD}	Supply Voltage

Note:

0.1µF capacitor is a by-pass power supply filter capacitor placed between Pin4 (V_{DD}) and Ground for optimal performance.

VCXO Function

VCXO Feature: The VT-704 is supplied with a VCXO function for applications where it will be used in a PLL, or the output frequency needs fine tune or calibration adjustments. This is a high impedance input, 100kOhm, and can be driven with an op-amp or terminated with adjustable resistors etc. **Pin1 should not be left floating on the VCXO optional device.**

Maximum Ratings

Absolute Maximum Ratings and Handling Precautions

Stresses in excess of the absolute maximum ratings can permanently damage the device. Functional operation is not implied or any other excess of conditions represented in the operational sections of this data sheet. Exposure to absolute maximum ratings for extended periods may adversely affect device reliability.

Although ESD protection circuitry has been designed into the VT-704, proper precautions should be taken when handling and mounting, VI employs a Human Body Model and Charged Device Model for ESD susceptibility testing and design evaluation.

ESD thresholds are dependent on the circuit parameters used to define the model. Although no industry standard has been adopted for the CDM a standard resistance of 1.5kOhms and capacitance of 100pF is widely used and therefore can be used for comparison purposes.

Parameter	Symbol	Rating	Unit
Storage Temperature	T _{STORE}	-55/125	°C
Supply Voltage	V _{DD}	-0.6/6	V
Control Voltage	V _c	-0.6/V _{DD} +0.6	V
Enable/Disable Voltage	E/D	-0.6/V _{DD} +0.6	V
ESD, Human Body Model		1500	V
ESD, Charged Device Model		1000	V

Reliability

Table 5. Environmental Compliance

Parameter	Condition
Mechanical Shock	MIL-STD-883 Method 2002
Mechanical Vibration	MIL-STD-883 Method 2007
Temperature Cycle	MIL-STD-883 Method 1010
Solderability	MIL-STD-883 Method 2003
Fine and Gross Leak	MIL-STD-883 Method 1014
Resistance to Solvents	MIL-STD-883 Method 2015
Moisture Sensitivity Level	MSL1
Contact Pads	Gold over Nickel

IR Reflow

Suggested IR Profile

Devices are built using lead free epoxy and can be subjected to standard lead free IR reflow conditions shown in Table 6. Contact pads are gold over nickel and lower maximum temperatures can also be used, such as 220°C.

Table 6. Reflow Profile

Parameter	Symbol	Value
PreHeat Time Ts-min Ts-max	t_s	200 sec Max 150°C 200°C
Ramp Up	R_{UP}	3°C/sec Max
Time above 217C	t_L	150 sec Max
Time to Peak Temperature	$t_{25C \text{ to peak}}$	480 sec Max
Time at 260C	t_p	30 sec Max
Time at 240C	t_{p2}	60 sec Max
Ramp down	R_{DN}	6°C/sec Max

Solderprofile:

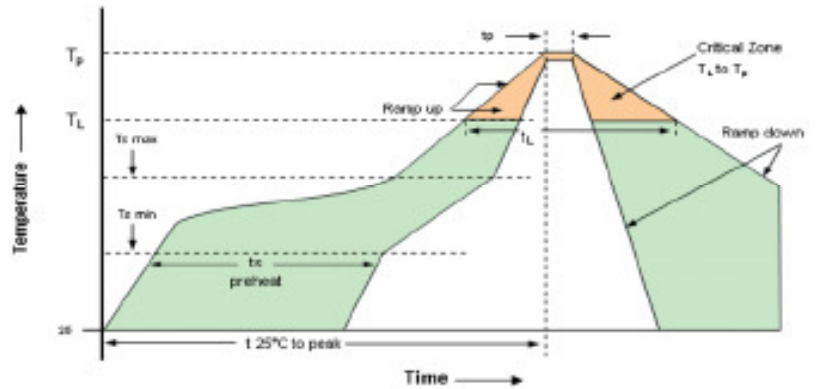

Tape & Reel

Table 7. Tape and Reel Information

Tape Dimensions (mm)					Reel Dimensions (mm)							
W	F	Do	Po	P1	A	B	C	D	N	W1	W2	#/Reel
16	7.5	1.5	4	8	180	1.5	13	20.2	60	16.4	20.4	1000

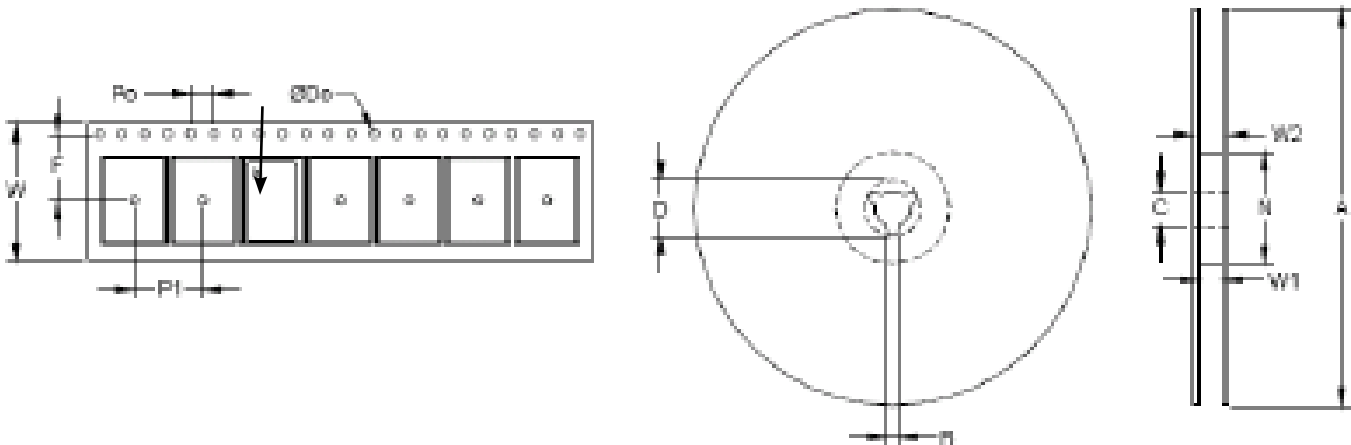

Ordering Information

Table 8. Standard Frequencies (MHz)

8.000	8.192	10.000	12.800	16.000	16.384	19.200	19.440	25.000	26.000
40.000									

Note: Other Frequencies are available on request.

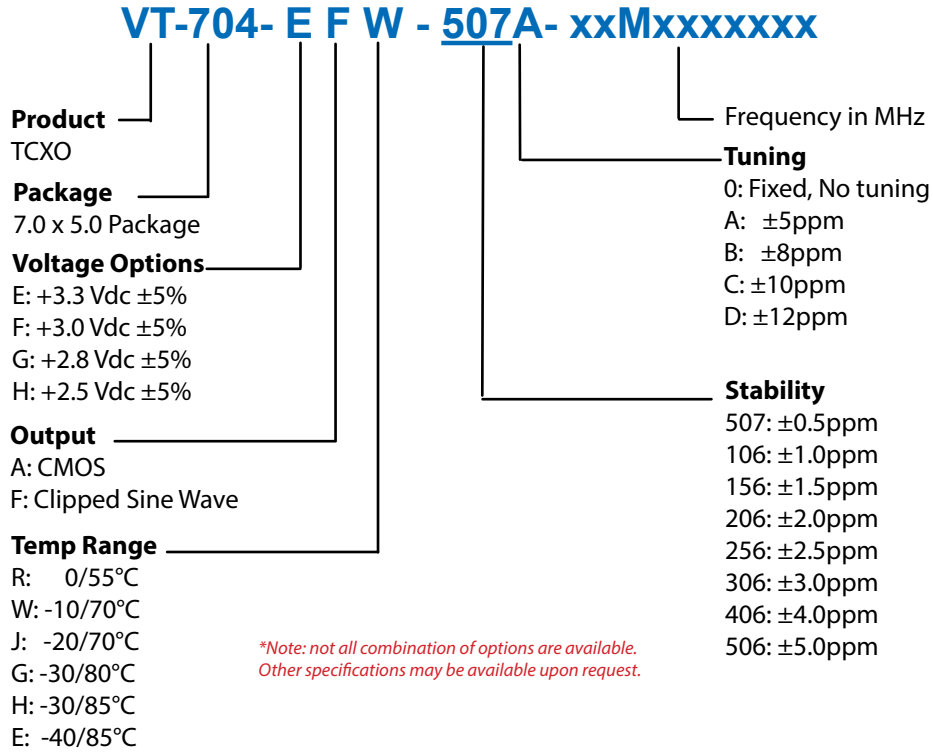

Example: VT-704-EFW-507A-12M8000000

* Add **_SNPBDIP** for tin lead solder dip
Example: VT-704-EFW-507A-12M8000000_SNPBDIP

Revision History

Revision Date	Approved	Description
May 4, 2015	VN	Rev 0.1: VT-704 Product Preliminary Datasheet - Internal Verification
May 11, 2015	VN	Rev 0.2: Preliminary Datasheet Website (Product Launch)
June 16, 2015	VN	Rev 0.3: Added temperature code "G" for -30/80 °C operating temperature range
June 14, 2016	VN	Rev 0.4: Removed "Preliminary".
August 10, 2018	FB	Updated logo and contact information,, added "SNPDIP" ordering option



Microsemi Headquarters
One Enterprise, Aliso Viejo, CA 92656 USA
Within the USA: +1 (800) 713-4113
Outside the USA: +1 (949) 380-6100
Sales: +1 (949) 380-6136
Fax: +1 (949) 215-4996
email: sales.support@microsemi.com
www.microsemi.com

Microsemi, a wholly owned subsidiary of Microchip Technology Inc. (Nasdaq: MCHP), offers a comprehensive portfolio of semiconductor and system solutions for aerospace & defense, communications, data center and industrial markets. Products include high-performance and radiation-hardened analog mixed-signal integrated circuits, FPGAs, SoCs and ASICs, power management products; timing and synchronization devices and precise time solutions, setting the world's standard for time; voice processing devices; RF solutions; discrete components; enterprise storage and communication solutions, security technologies and scalable anti-tamper products; Ethernet solutions; Power-over-Ethernet ICs and midspans, as well as custom design capabilities and services. Learn more at www.microsemi.com.

Microsemi makes no warranty, representation, or guarantee regarding the information contained herein or the suitability of its products and services for any particular purpose, nor does Microsemi assume any liability whatsoever arising out of the application or use of any product or circuit. The products sold hereunder and any other products sold by Microsemi have been subject to limited testing and should not be used in conjunction with mission-critical equipment or applications. Any performance specifications are believed to be reliable but are not verified, and Buyer must conduct and complete all performance and other testing of the products, alone and together with, or installed in, any end-products. Buyer shall not rely on any data and performance specifications or parameters provided by Microsemi. It is the Buyer's responsibility to independently determine suitability of any products and to test and verify the same. The information provided by Microsemi hereunder is provided "as is, where is" and with all faults, and the entire risk associated with such information is entirely with the Buyer. Microsemi does not grant, explicitly or implicitly, to any party any patent rights, licenses, or any other IP rights, whether with regard to such information itself or anything described by such information. Information provided in this document is proprietary to Microsemi, and Microsemi reserves the right to make any changes to the information in this document or to any products and services at any time without notice.

©2018 Microsemi, a wholly owned subsidiary of Microchip Technology Inc. All rights reserved. Microsemi and the Microsemi logo are registered trademarks of Microsemi Corporation. All other trademarks and service marks are the property of their respective owners.