

REVISIONS																					
LTR	DESCRIPTION														DATE (YR-MO-DA)			APPROVED			
A	Add case outlines T and U. Change limits for V_{OUT} , line regulation, load regulation, standby current drain; with line and with load tests. Change footnotes <u>1/</u> , <u>2/</u> , and <u>5/</u> . Add vendors CAGE U4637 and 69210.														89-07-24			M. A. FRYE			
B	Add case outline 2. Change limit for ripple rejection test. Editorial changes throughout.														92-11-16			M. A. FRYE			
C	Add device type 02. Add case outline P. Technical and editorial changes throughout.														93-11-09			M. A. FRYE			
D	Add case outline N. Make changes to 1.2.2, 1.3, table I, figure 1, and figure 2. - ro														99-10-20			R. MONNIN			
E	Add case outline M. Make changes to 1.2.2, 1.3, table I, figure 1, and figure 2. -ro														99-12-17			R. MONNIN			
F	Add radiation hardness requirements. Add CAGE 21845. -rrp														00-02-01			R. MONNIN			
G	Make change to case outline N. Add case outlines 4 and 5. Make changes to 1.2.3, 1.3, figure 1, and figure 2. -rrp														02-02-11			R. MONNIN			
H	Make change to V_{IN} limits to Ripple rejection test and footnote <u>3/</u> as specified in table I. - ro														02-10-09			R. MONNIN			
J	For case outlines T and U only, add footnote <u>1/</u> under 1.2.3 and add note 2 under figure 1. Drawing updated to reflect current requirements. -rrp														06-01-11			R. MONNIN			
THE ORIGINAL FIRST PAGE OF THIS DRAWING HAS BEEN REPLACED.																					
REV																					
SHEET																					
REV	J	J	J	J	J																
SHEET	15	16	17	18	19																
REV STATUS				REV				J	J	J	J	J	J	J	J	J	J	J	J		
OF SHEETS				SHEET				1	2	3	4	5	6	7	8	9	10	11	12	13	14
PMIC N/A				PREPARED BY CHARLES E. BESORE						DEFENSE SUPPLY CENTER COLUMBUS COLUMBUS, OHIO 43218-3990 http://www.dsccl.dla.mil											
STANDARD MICROCIRCUIT DRAWING				CHECKED BY RAY MONNIN																	
THIS DRAWING IS AVAILABLE FOR USE BY ALL DEPARTMENTS AND AGENCIES OF THE DEPARTMENT OF DEFENSE AMSC N/A				APPROVED BY D. A. DiCENZO						MICROCIRCUIT, LINEAR, POSITIVE 12 VOLT REGULATOR, MONOLITHIC SILICON											
				DRAWING APPROVAL DATE 88-07-28																	
				REVISION LEVEL J						SIZE A	CAGE CODE 67268	5962-87776									
						SHEET 1 OF 19															

1. SCOPE

1.1 Scope. This drawing describes device requirements for MIL-STD-883 compliant, non-JAN class level B microcircuits in accordance with MIL-PRF-38535, appendix A.

1.2 Part or Identifying Number (PIN). The complete PIN is as shown in the following example:

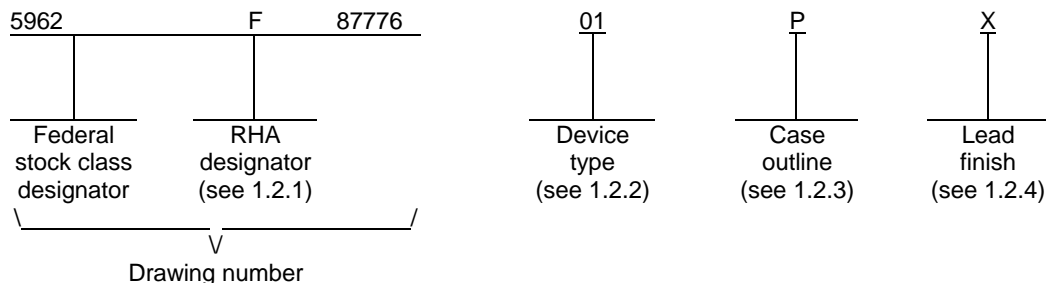

1.2.1 RHA designator. RHA marked devices shall meet the MIL-PRF-38535 or MIL-PRF-38535, Appendix A specified RHA levels and shall be marked with the appropriate RHA designator. A dash (-) indicates a non-RHA device.

1.2.2 Device type(s). The device type(s) identify the circuit function as follows:

<u>Device type</u>	<u>Generic number</u>	<u>Circuit function</u>
01	7812A	Positive regulator, fixed, 12 volt
02	78M12	Positive regulator, fixed, 12 volt

1.2.3 Case outline(s). The case outline(s) are as designated in MIL-STD-1835 and as follows:

<u>Outline letter</u>	<u>Descriptive designator</u>	<u>Terminals</u>	<u>Package style</u>
M	See figure 1	3	Power surface mount
N	CBCC2-N3	3	Bottom terminal chip carrier
P	GDIP1-T8 or CDIP2-T8	8	Dual-in-line
T <u>1/</u>	See figure 1	3	TO-257 flange mounted and glass sealed
U <u>1/</u>	See figure 1	3	TO-257 flange mounted with isolated tab and glass sealed
X	See figure 1	3	TO-39 can
Y	See figure 1	2	TO-3 can
Z	MBFM4-P2	2	TO-66 can
2	CQCC1-N20	20	Square leadless chip carrier
4	See figure 1	3	Flange mount, glass sealed, with gull wings
5	CBCC1-N3	3	Bottom terminal chip carrier

1.2.4 Lead finish. The lead finish is as specified in MIL-PRF-38535, appendix A.

1/ For outline letters T and U, CAGE 34333 manufacturers the TO-257 package with ceramic seal.

STANDARD MICROCIRCUIT DRAWING DEFENSE SUPPLY CENTER COLUMBUS COLUMBUS, OHIO 43218-3990	SIZE A		5962-87776
		REVISION LEVEL J	SHEET 2

1.3 Absolute maximum ratings.

Input voltage:

Operating or output shorted to ground (Device types 01 and 02) 35 V dc
 Transient (Device type 01) 50 V dc 2/

Output current (I_O)

Cases M, N, T, U, Y, Z, 4, and 5 1.5 A
 Cases P, X, and 2 (Device type 01) 0.5 A

Power dissipation (P_D):

T_C = +25°C:

Device type 01, cases M, N, T, U, Z, 4, and 5 15 W
 Device type 01, cases X and 2 2 W
 Device type 01, case Y 20 W

T_A = +25°C:

Device type 01, cases M, N, T, U, and Z 3.0 W
 Device type 01, cases X and 2 1.0 W
 Device type 01, case Y 4.3 W
 Device type 01, case 4 1.7 W
 Device type 01, case 5 1.3 W
 Device type 02, case P 1050 mW 3/
 Device type 02, case 2 1375 mW 4/

Storage temperature range -65°C to +150°C

Lead temperature (soldering, 10 seconds) +300°C

Case temperature, case outline 2 (soldering, 10 seconds):

Device type 02 +260°C

Junction temperature (T_J) +150°C 5/

Thermal resistance, junction-to-case (θ_{JC}):

Cases M and U 4.2°C/W
 Cases N and T 3.5°C/W
 Cases P and 2 See MIL-STD-1835
 Case X 15°C/W
 Case Y 3°C/W
 Case Z 6°C/W
 Case 4 5.1°C/W
 Case 5 3.6°C/W

Thermal resistance, junction-to-ambient (θ_{JA}):

Device type 01, cases M, N, T, U, and Z 42°C/W
 Device type 01, cases X and 2 120°C/W
 Device type 01, case Y 35°C/W
 Device type 01, case 4 60°C/W
 Device type 01, case 5 80°C/W
 Device type 02, case P 110°C/W
 Device type 02, case 2 65°C/W

2/ The 50 volt input rating refers to the ability of the regulator to withstand high line or transient conditions without damage. Since the regulator's maximum current capability is reduced, the output may fall out of regulation at high input voltages under nominal loading.

3/ Derate at 8.4 mW/°C above T_A = +25°C.

4/ Derate at 11.0 mW/°C above T_A = +25°C.

5/ The device is protected by thermal shutdown circuit which is designed to turn off the output transistor whenever the device junction temperature is in excess of +150°C.

STANDARD MICROCIRCUIT DRAWING DEFENSE SUPPLY CENTER COLUMBUS COLUMBUS, OHIO 43218-3990	SIZE A		5962-87776
		REVISION LEVEL J	SHEET 3

1.4 Recommended operating conditions.

Input voltage range (V_{IN}) +8 V dc to +25 V dc
 Ambient operating temperature range (T_A) -55°C to +125°C

1.5 Radiation features:

Maximum total dose available (dose rate = 50 – 300 rads(Si)/s)..... 300 Krads(Si) 6/

2. APPLICABLE DOCUMENTS

2.1 Government specification, standards, and handbooks. The following specification, standards, and handbooks form a part of this drawing to the extent specified herein. Unless otherwise specified, the issues of these documents are those cited in the solicitation or contract.

DEPARTMENT OF DEFENSE SPECIFICATION

MIL-PRF-38535 - Integrated Circuits, Manufacturing, General Specification for.

DEPARTMENT OF DEFENSE STANDARDS

MIL-STD-883 - Test Method Standard Microcircuits.
 MIL-STD-1835 - Interface Standard Electronic Component Case Outlines.

DEPARTMENT OF DEFENSE HANDBOOKS

MIL-HDBK-103 - List of Standard Microcircuit Drawings.
 MIL-HDBK-780 - Standard Microcircuit Drawings.

(Copies of these documents are available online at <http://assist.daps.dla.mil/quicksearch/> or <http://assist.daps.dla.mil> or from the Standardization Document Order Desk, 700 Robbins Avenue, Building 4D, Philadelphia, PA 19111-5094.)

2.2 Order of precedence. In the event of a conflict between the text of this drawing and the references cited herein, the text of this drawing takes precedence. Nothing in this document, however, supersedes applicable laws and regulations unless a specific exemption has been obtained.

6/ These parts may be dose rate sensitive in a space environment and may demonstrate enhanced low dose rate effects. Radiation end point limits for the noted parameters are guaranteed only for the conditions specified in MIL-STD-883, method 1019, condition A.

STANDARD MICROCIRCUIT DRAWING DEFENSE SUPPLY CENTER COLUMBUS COLUMBUS, OHIO 43218-3990	SIZE A		5962-87776
		REVISION LEVEL J	SHEET 4

3. REQUIREMENTS

3.1 Item requirements. The individual item requirements shall be in accordance with MIL-PRF-38535, appendix A for non-JAN class level B devices and as specified herein. Product built to this drawing that is produced by a Qualified Manufacturer Listing (QML) certified and qualified manufacturer or a manufacturer who has been granted transitional certification to MIL-PRF-38535 may be processed as QML product in accordance with the manufacturers approved program plan and qualifying activity approval in accordance with MIL-PRF-38535. This QML flow as documented in the Quality Management (QM) plan may make modifications to the requirements herein. These modifications shall not affect form, fit, or function of the device. These modifications shall not affect the PIN as described herein. A "Q" or "QML" certification mark in accordance with MIL-PRF-38535 is required to identify when the QML flow option is used.

3.2 Design, construction, and physical dimensions. The design, construction, and physical dimensions shall be as specified in MIL-PRF-38535, appendix A and herein.

3.2.1 Case outline. The case outline shall be in accordance with 1.2.3 herein and figure 1.

3.2.2 Terminal connections. The terminal connections shall be as specified on figure 2.

3.2.3 Radiation exposure circuit. The radiation exposure circuit shall be as specified on figure 3.

3.3 Electrical performance characteristics. Unless otherwise specified herein, the electrical performance characteristics are as specified in table I and shall apply over the full ambient operating temperature range.

3.4 Electrical test requirements. The electrical test requirements shall be the subgroups specified in table II. The electrical tests for each subgroup are described in table I.

3.5 Marking. Marking shall be in accordance with MIL-PRF-38535, appendix A. The part shall be marked with the PIN listed in 1.2 herein. In addition, the manufacturer's PIN may also be marked. For packages where marking of the entire SMD PIN number is not feasible due to space limitations, the manufacturer has the option of not marking the "5962-" on the device.

3.5.1 Certification/compliance mark. A compliance indicator "C" shall be marked on all non-JAN devices built in compliance to MIL-PRF-38535, appendix A. The compliance indicator "C" shall be replaced with a "Q" or "QML" certification mark in accordance with MIL-PRF-38535 to identify when the QML flow option is used.

3.6 Certificate of compliance. A certificate of compliance shall be required from a manufacturer in order to be listed as an approved source of supply in MIL-HDBK-103 (see 6.6 herein). The certificate of compliance submitted to DSCC-VA prior to listing as an approved source of supply shall affirm that the manufacturer's product meets the requirements of MIL-PRF-38535, appendix A and the requirements herein.

3.7 Certificate of conformance. A certificate of conformance as required in MIL-PRF-38535, appendix A shall be provided with each lot of microcircuits delivered to this drawing.

3.8 Notification of change. Notification of change to DSCC-VA shall be required for any change that affects this drawing.

3.9 Verification and review. DSCC, DSCC's agent, and the acquiring activity retain the option to review the manufacturer's facility and applicable required documentation. Offshore documentation shall be made available onshore at the option of the reviewer.

STANDARD MICROCIRCUIT DRAWING DEFENSE SUPPLY CENTER COLUMBUS COLUMBUS, OHIO 43218-3990	SIZE A		5962-87776
		REVISION LEVEL J	SHEET 5

TABLE I. Electrical performance characteristics.

Test	Symbol	Conditions <u>1/ 2/ 3/</u> -55°C ≤ T _A ≤ +125°C unless otherwise specified	Group A subgroups	Device type	Limits		Unit
					Min	Max	
Output voltage	V _{OUT}	T _A = +25°C	1	01	11.88	12.12	V
		M,D,P,L,R,F	1		11.88	12.12	
		T _A = +25°C	1	02	11.5	12.5	
		V _{IN} = 14.5 V to 27 V <u>4/</u>	1,2,3	01	11.64	12.36	
		M,D,P,L,R,F	1		11.64	12.36	
V _{IN} = 15.5 V to 27 V <u>4/</u>	1,2,3	02	11.4	12.6			
Ripple rejection <u>5/</u>	ΔV _{IN} / ΔV _{OUT}	f = 120 Hz, V _{IN} = 19 V	4	01	61		dB
			5,6 <u>6/</u>		54		
		M,D,P,L,R,F	4		61		
		f = 120 Hz, I _{OUT} = 100 mA, V _{IN} = 15 V to 25 V	4,5,6 <u>6/</u>	02	55		
		f = 120 Hz, I _{OUT} = 300 mA, V _{IN} = 15 V to 25 V	4 <u>6/</u>		55		
Line regulation <u>5/ 7/</u>	V _{RLINE}	V _{IN} = 14.5 V to 27 V	1	01		18	mV
		-55°C ≤ T _J ≤ +125°C	2,3			50	
		M,D,P,L,R,F	1			18	
		V _{IN} = 16 V to 22 V	1			9	
		-55°C ≤ T _J ≤ +125°C	2,3			30	
		M,D,P,L,R,F	1			9	
		V _{IN} = 14.5 V to 30 V, T _A = +25°C	1	02		60	
		V _{IN} = 16 V to 25 V, T _A = +25°C	1			30	

See footnotes at end of table.

STANDARD MICROCIRCUIT DRAWING DEFENSE SUPPLY CENTER COLUMBUS COLUMBUS, OHIO 43218-3990	SIZE A		5962-87776
		REVISION LEVEL J	SHEET 6

TABLE I. Electrical performance characteristics- Continued.

Test	Symbol	Conditions <u>1/ 2/ 3/</u> -55°C ≤ T _A ≤ +125°C unless otherwise specified	Group A subgroups	Device type	Limits		Unit
					Min	Max	
Load regulation <u>5/</u>	V _{RLOAD}	I _O = 5.0 mA to 1.5 A, <u>8/</u> -55°C ≤ T _J ≤ +125°C	1	01		32	mV
			M,D,P,L,R,F		1		
		I _O = 5.0 mA to 1.0 A, <u>8/</u> -55°C ≤ T _J ≤ +125°C	2,3		60		
			I _O = 250 mA to 750 mA, <u>8/</u> -55°C ≤ T _J ≤ +125°C	1	01		
		2,3				40	
		M,D,P,L,R,F	1		20		
			I _O = 5.0 mA to 500 mA, <u>9/</u> -55°C ≤ T _J ≤ +125°C	1	01		
		2,3				60	
		1				30	
		I _O = 5.0 mA to 500 mA, T _A = 25°C	1	02		120	
I _O = 5.0 mA to 200 mA, T _A = 25°C	1	02		60			
Standby current drain	I _{SCD}		1	01		6.0	mA
			2,3			6.5	
			M,D,P,L,R,F		1		
				1	02		
Standby current drain change with line	ΔI _{SCD} (line)	V _{IN} = 15 V to 30 V	1,2,3	01		0.8	mA
			M,D,P,L,R,F		1		
		V _{IN} = 15 V to 30 V, I _O = 200 mA	1,2,3	02		0.8	

See footnotes at end of table.

STANDARD MICROCIRCUIT DRAWING DEFENSE SUPPLY CENTER COLUMBUS COLUMBUS, OHIO 43218-3990	SIZE A		5962-87776
		REVISION LEVEL J	SHEET 7

TABLE I. Electrical performance characteristics- Continued.

Test	Symbol	Conditions <u>1/ 2/ 3/</u> -55°C ≤ T _A ≤ +125°C unless otherwise specified	Group A subgroups	Device type	Limits		Unit
					Min	Max	
Standby current drain change with load	ΔI _{SCD} (load)	I _O = 5.0 mA to 1 A <u>8/</u>	1,2,3	01		0.5	mA
			M,D,P,L,R,F		1		
		I _O = 5.0 mA to 500 mA <u>9/</u>	1,2,3			0.5	
			1			0.5	
		I _O = 5.0 mA to 350 mA	1,2,3	02		0.5	
Dropout voltage	VDO	ΔV _{OUT} = 100 mV, <u>8/</u> I _O = 1.0 A	1,2,3	01		2.5	V
			M,D,P,L,R,F		1		
		ΔV _{OUT} = 100 mV, <u>9/</u> I _O = 500 mA	1,2,3			2.5	
			1			2.5	
		I _O = 350 mA, T _A = +25°C	1	02		2.5	
Peak output current	I _{O(PK)}	T _A = +25°C <u>8/</u>	1	01	1.5	3.3	A
			M,D,P,L,R,F		1	1.5	
		T _A = +25°C <u>9/</u>	1		0.5	1.7	
			1		0.5	1.7	
		T _A = +25°C <u>6/</u>	1	02	0.5	1.4	
Short circuit current <u>10/</u>	I _{OS}	V _{IN} = 35 V <u>8/</u>	1	01		1.2	A
			2,3			2.8	
			M,D,P,L,R,F		1		
		V _{IN} = 35 V <u>9/</u>	1			0.7	
			2,3			2.0	
			1			0.7	
		V _{IN} = 35 V	1	02		0.6	
Output noise voltage <u>6/</u>	N _O	f = 10 Hz to 100 kHz, T _A = +25°C	7	01		40	μV / V rms
			M,D,P,L,R,F		7		
		f = 10 Hz to 100 kHz, T _A = +25°C	7	02		480	μV

See footnotes at end of table.

STANDARD MICROCIRCUIT DRAWING DEFENSE SUPPLY CENTER COLUMBUS COLUMBUS, OHIO 43218-3990	SIZE A		5962-87776
		REVISION LEVEL J	SHEET 8

TABLE I. Electrical performance characteristics- Continued.

Test	Symbol	Conditions <u>1/ 2/ 3/</u> -55°C ≤ T _A ≤ +125°C unless otherwise specified	Group A subgroups	Device type	Limits		Unit
					Min	Max	
Long term stability	$\Delta V_{OUT} / \Delta t$	T _A = +25°C, <u>6/</u> t = 1,000 hours	7	01		75	mV
		M,D,P,L,R,F	7			75	
Temperature coefficient <u>6/</u>	$\Delta T / \Delta t$	I _O = 5.0 mA, T _A = -55°C to +25°C	1,3	02		-4.8	mV/°C
		I _O = 5.0 mA, T _A = +25°C to +125°C	1,2			-3.6	

- 1/ Devices supplied to this drawing will meet all levels M, D, P, L, R, F of irradiation. However, this device is only tested at the 'F' level. Pre and Post irradiation values are identical unless otherwise specified in table I. When performing post irradiation electrical measurements for any RHA level, T_A = +25°C.
- 2/ These parts may be dose rate sensitive in a space environment and may demonstrate enhanced low dose rate effects. Radiation end point limits for the noted parameters are guaranteed only for the conditions specified in MIL-STD-883, method 1019, condition A.
- 3/ Unless otherwise specified, for device type 01, V_{IN} = 19 V and I_O = 500 mA for cases M, N, T, U, Y, Z, 4, and 5. V_{IN} = 19 V and I_O = 100 mA for cases X and 2. Maximum test current for cases X and 2 is 500 mA. For device type 02, V_{IN} = 19 V and I_O = 350 mA for case P and 2.
- 4/ For device type 01, cases P, X, and 2: I_O = 5 mA to 500 mA, P ≤ 2 W. For device type 01, case Y: I_O = 5 mA to 1.0 A, P ≤ 20 W. For case type 01, cases M, N, T, U, Z, 4, and 5: I_O = 5 mA to 1.0 A, P ≤ 15 W. For device type 02, cases P and 2: I_O = 5 mA to 350 mA, P ≤ 1.3 W.
- 5/ All measurements except output noise voltage and ripple rejection are made at constant junction temperature and with low duty cycle.
- 6/ Guaranteed, if not tested, to the limits specified.
- 7/ Minimum load current for full line regulation is 5.0 mA.
- 8/ For cases M, N, T, U, Y, Z, 4, and 5 only.
- 9/ For cases X and 2 only.
- 10/ Short circuit protection is only assured up to V_{IN} = 35 V.

STANDARD MICROCIRCUIT DRAWING DEFENSE SUPPLY CENTER COLUMBUS COLUMBUS, OHIO 43218-3990	SIZE A		5962-87776
		REVISION LEVEL J	SHEET 9

Case outline M

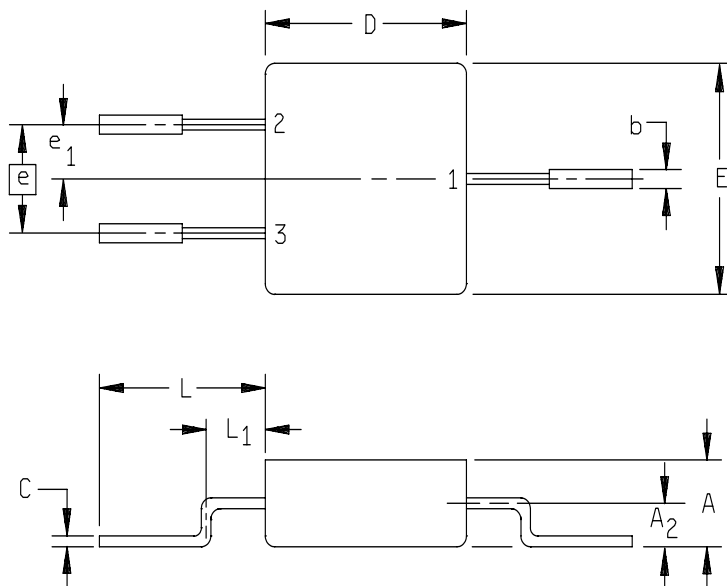

Symbol	Inches		Millimeters	
	Min	Max	Min	Max
A	.160	---	4.06	---
A ₂	.080	---	2.03	---
b	---	.035	---	0.89
C	.020	---	0.51	---
D	---	.425	---	10.8
E	---	.425	---	10.8
e	.200 BSC		5.08 BSC	
e ₁	.100 BSC		2.54 BSC	
L	.350	---	8.89	---
L ₁	---	.135	---	3.43

NOTES:

1. The U.S. government preferred system of measurement is the metric SI system. However, since this item was originally designed using inch-pound units of measurement, in the event of conflict between the metric and inch-pound units, the inch-pound units shall take precedence.
2. Three leads.

FIGURE 1. Case outline.

STANDARD MICROCIRCUIT DRAWING DEFENSE SUPPLY CENTER COLUMBUS COLUMBUS, OHIO 43218-3990	SIZE A		5962-87776
		REVISION LEVEL J	SHEET 10

Case outlines T and U

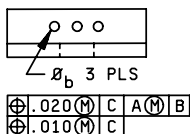
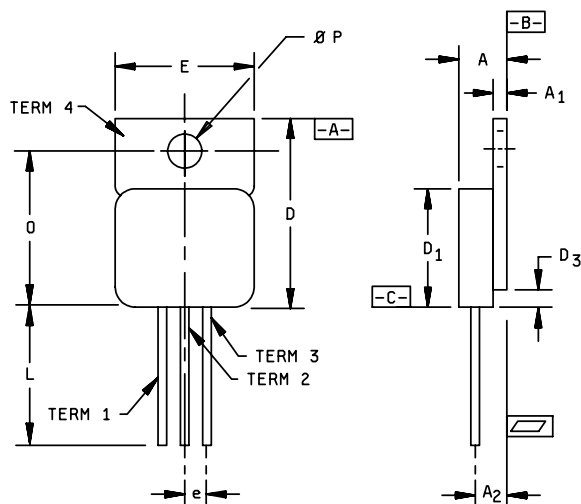

Letter	Inches		Millimeters	
	Min	Max	Min	Max
A	.190	.200	4.83	5.08
A1	.035	.045	0.89	1.14
A2	.120 BSC		3.05 BSC	
ϕ b	.025	.035	0.64	0.89
D	.645	.665	16.38	16.89
D1	.410	.430	10.41	10.92
D3	.000	.065	0.00	1.65
e	.100 BSC		2.54 BSC	
E	.410	.422	10.41	10.71
L	.500	.750	12.70	19.05
O	.527	.537	13.39	16.64
ϕ P	.140	.150	3.56	3.81

NOTES:

1. The U.S. government preferred system of measurement is the metric SI system. However, since this item was originally designed using inch-pound units of measurement, in the event of conflict between the metric and inch-pound units, the inch-pound units shall take precedence.
2. For case outlines T and U only, CAGE code 34333, the ceramic seal that protrudes from the seating plane is not to be considered in overall package dimensions. The ceramic seal protrusion is considered uncontrolled within an area 30 mils from the seating plane.

FIGURE 1. Case outline – Continued.

STANDARD MICROCIRCUIT DRAWING DEFENSE SUPPLY CENTER COLUMBUS COLUMBUS, OHIO 43218-3990	SIZE A		5962-87776
		REVISION LEVEL J	SHEET 11

Case outline Y

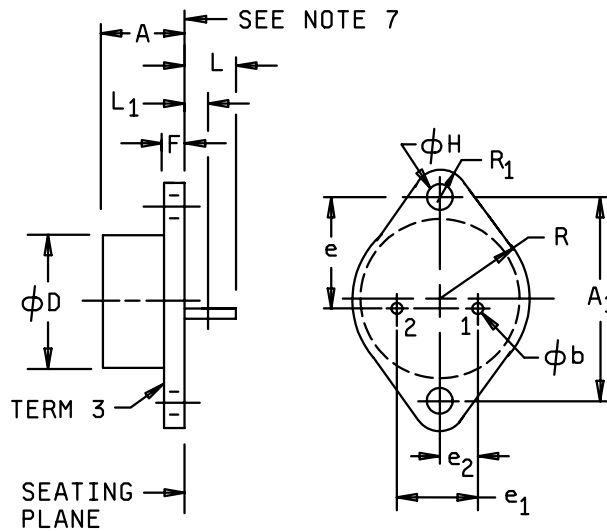

Symbol	Inches		Millimeters		Notes
	Min	Max	Min	Max	
A	.250	.450	6.35	11.43	
A ₁	1.177	1.197	29.90	30.40	
phi b	.038	.043	.97	1.09	4,8
phi D	---	.875	---	22.22	
e	.655	.675	16.64	17.14	
e ₁	.420	.440	10.67	11.16	
e ₂	.205	.225	5.21	5.72	
F	.060	.135	1.52	3.43	
phi H	.151	.161	3.84	4.09	6,7
L	.312	.500	7.92	12.70	5
L ₁	---	.050	---	1.27	4,5
R	.495	.525	12.57	13.34	
R ₁	.131	.188	3.33	4.78	

NOTES:

1. The U.S. government preferred system of measurement is the metric SI system. However, since this item was originally designed using inch-pound units of measurement, in the event of conflict between the metric and inch-pound units, the inch-pound units shall take precedence.
2. Dimensions shall be measured in inches.
3. Metric equivalents are given for general information only.
4. phi b applies between L₁ (all leads) and .500 inch (12.70 mm) from the seating plane.
5. Two leads.
6. Two holes.
7. Leads having a maximum diameter of .043 inch (1.09 mm) measured in gauging plane .054 inch (1.37 mm) + .001 inch (0.03 mm) - .000 inch (0.00 mm) below the base plane shall be located at true position within diameter .014 inch (0.36 mm).
8. The mounting surface of the header shall be flat to convex within .003 inch (0.08 mm) inside a .930 inch (23.62 mm) diameter circle on the center of the header and flat to convex within .006 inch (0.15 mm) overall.

FIGURE 1. Case outline – Continued.

STANDARD MICROCIRCUIT DRAWING DEFENSE SUPPLY CENTER COLUMBUS COLUMBUS, OHIO 43218-3990	SIZE A		5962-87776
		REVISION LEVEL J	SHEET 13

Case outline 4

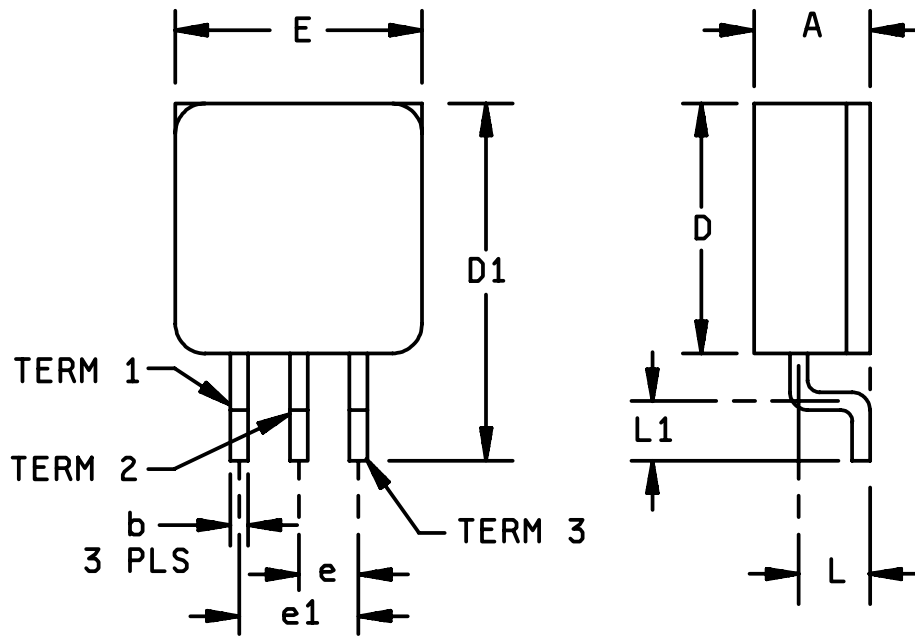

Symbol	Inches		Millimeters	
	Min	Max	Min	Max
A	.190	.210	4.83	5.33
b	---	.030	---	0.76
D	.410	.430	10.41	10.92
D1	.580	.610	14.73	15.49
e	---	.100	---	2.54
e1	---	.200	---	5.08
E	.410	.420	10.41	10.67
L1	.090	.110	2.29	2.79
L	.115	.125	2.92	3.18
N	3		3	

NOTE:

The U.S. government preferred system of measurement is the metric SI system. However, since this item was originally designed using inch-pound units of measurement, in the event of conflict between the metric and inch-pound units, the inch-pound units shall take precedence.

FIGURE 1. Case outline – Continued.

STANDARD MICROCIRCUIT DRAWING DEFENSE SUPPLY CENTER COLUMBUS COLUMBUS, OHIO 43218-3990	SIZE A		5962-87776
		REVISION LEVEL J	SHEET 14

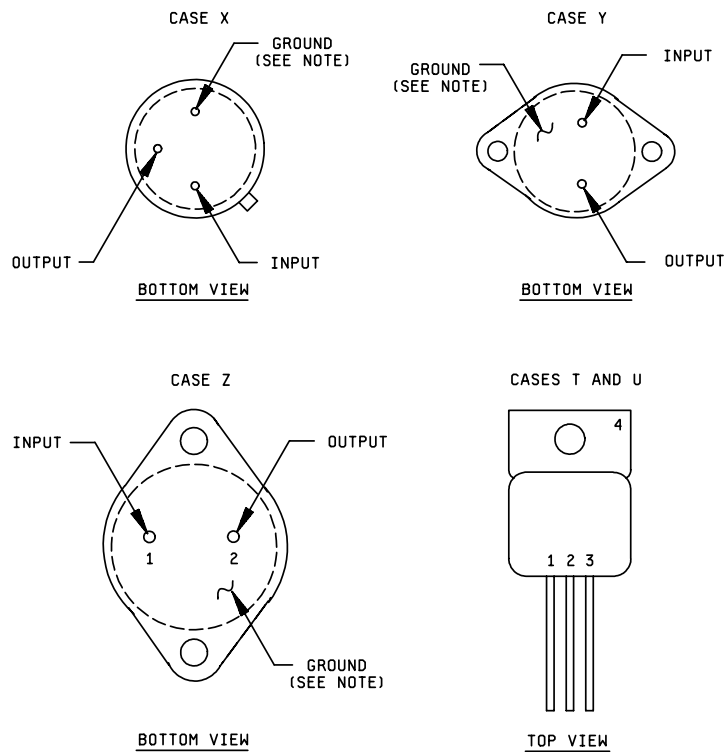

NOTE: Case is connected to ground.

FIGURE 2. Terminal connections.

STANDARD MICROCIRCUIT DRAWING DEFENSE SUPPLY CENTER COLUMBUS COLUMBUS, OHIO 43218-3990	SIZE A		5962-87776
		REVISION LEVEL J	SHEET 15

Device types	01							02	
Case outlines	M	N	T	U	2	4	5	P	2
Terminal number	Terminal symbol								
1	OUTPUT	OUTPUT	INPUT	INPUT	NC	INPUT	OUTPUT	GND	NC
2	ADJUST	INPUT	GND	GND	V _{IN}	GND	INPUT	NC	GND
3	INPUT	GND	OUTPUT	OUTPUT	NC	OUTPUT	GND	NC	NC
4	ISOLATED (CASE)	---	GND	NC	NC	---	---	V _{IN}	NC
5	---	---	---	---	NC	---	---	NC	NC
6	---	---	---	---	NC	---	---	V _{OUT}	NC
7	---	---	---	---	GND	---	---	NC	NC
8	---	---	---	---	NC	---	---	NC	NC
9	---	---	---	---	NC	---	---	---	NC
10	---	---	---	---	V _{OUT}	---	---	---	V _{IN}
11	---	---	---	---	NC	---	---	---	NC
12	---	---	---	---	V _{OUT}	---	---	---	NC
13	---	---	---	---	NC	---	---	---	NC
14	---	---	---	---	NC	---	---	---	NC
15	---	---	---	---	V _{OUT} SENSE	---	---	---	V _{OUT}
16	---	---	---	---	NC	---	---	---	NC
17	---	---	---	---	V _{IN}	---	---	---	NC
18	---	---	---	---	NC	---	---	---	NC
19	---	---	---	---	NC	---	---	---	NC
20	---	---	---	---	NC	---	---	---	NC

NOTES:

1. For case outline 2 normal operation, V_{OUT} SENSE must be connected externally to the load.
2. NC = No connection

FIGURE 2. Terminal connections - Continued.

STANDARD MICROCIRCUIT DRAWING DEFENSE SUPPLY CENTER COLUMBUS COLUMBUS, OHIO 43218-3990	SIZE A		5962-87776
		REVISION LEVEL J	SHEET 16

Case U

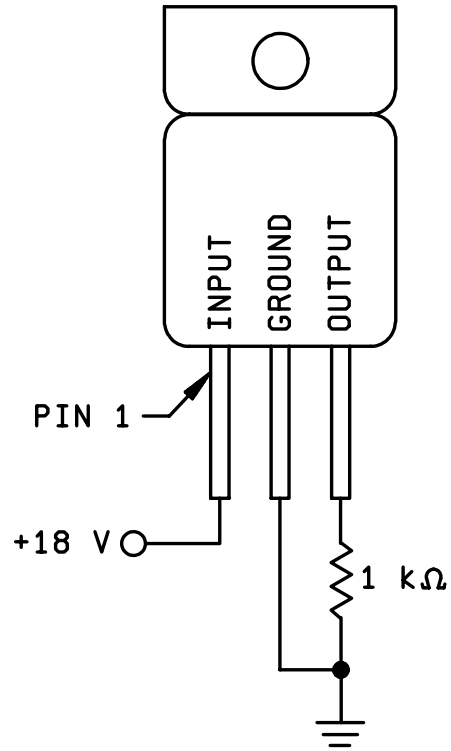

FIGURE 3. Radiation exposure circuit.

STANDARD MICROCIRCUIT DRAWING DEFENSE SUPPLY CENTER COLUMBUS COLUMBUS, OHIO 43218-3990	SIZE A		5962-87776
		REVISION LEVEL J	SHEET 17

4. VERIFICATION

4.1 Sampling and inspection. Sampling and inspection procedures shall be in accordance with MIL-PRF-38535, appendix A.

4.2 Screening. Screening shall be in accordance with method 5004 of MIL-STD-883, and shall be conducted on all devices prior to quality conformance inspection. The following additional criteria shall apply:

- a. Burn-in test, method 1015 of MIL-STD-883.
 - (1) Test condition A, B, C, or D. The test circuit shall be maintained by the manufacturer under document revision level control and shall be made available to the preparing or acquiring activity upon request. The test circuit shall specify the inputs, outputs, biases, and power dissipation, as applicable, in accordance with the intent specified in method 1015 of MIL-STD-883.
 - (2) $T_A = +125^{\circ}\text{C}$, minimum.
- b. Interim and final electrical test parameters shall be as specified in table II herein, except interim electrical parameter tests prior to burn-in are optional at the discretion of the manufacturer.

4.3 Quality conformance inspection. Quality conformance inspection shall be in accordance with method 5005 of MIL-STD-883 including groups A, B, C, and D inspections. The following additional criteria shall apply.

4.3.1 Group A inspection.

- a. Tests shall be as specified in table II herein.
- b. Subgroups 8, 9, 10, and 11 in table I, method 5005 of MIL-STD-883 shall be omitted.

4.3.2 Groups C and D inspections.

- a. End-point electrical parameters shall be as specified in table II herein.
- b. Steady-state life test conditions, method 1005 of MIL-STD-883.
 - (1) Test condition A, B, C, or D. The test circuit shall be maintained by the manufacturer under document revision level control and shall be made available to the preparing or acquiring activity upon request. The test circuit shall specify the inputs, outputs, biases, and power dissipation, as applicable, in accordance with the intent specified in method 1005 of MIL-STD-883.
 - (2) $T_A = +125^{\circ}\text{C}$, minimum.
 - (3) Test duration: 1,000 hours, except as permitted by method 1005 of MIL-STD-883.

4.3.3 Group E inspection. Group E inspection is required only for parts intended to be marked as radiation hardness assured (see 3.5 herein). RHA levels shall be as specified in MIL-PRF-38535 or MIL-PRF-38535, Appendix A. End-point parameters shall be as specified in table II herein.

4.3.3.1 Total dose irradiation testing. Total dose irradiation testing shall be performed in accordance with MIL-STD-883 method 1019, condition A and as specified herein.

STANDARD MICROCIRCUIT DRAWING DEFENSE SUPPLY CENTER COLUMBUS COLUMBUS, OHIO 43218-3990	SIZE A		5962-87776
		REVISION LEVEL J	SHEET 18

TABLE II. Electrical test requirements.

MIL-STD-883 test requirements	Subgroups (in accordance with MIL-STD-883, method 5005, table I)
Interim electrical parameters (method 5004)	1
Final electrical test parameters (method 5004)	1*, 2, 3, 4
Group A test requirements (method 5005)	1, 2, 3, 4**, 5**, 6**, 7**
Groups C and D end-point electrical parameters (method 5005)	1
Group E end-point electrical parameters (method 5005)	1, 4, 7

* PDA applies to subgroup 1.

** Subgroups 4, 5, 6, and 7, if not tested, shall be guaranteed to the limits specified in table I.

5. PACKAGING

5.1 Packaging requirements. The requirements for packaging shall be in accordance with MIL-PRF-38535, appendix A.

6. NOTES

6.1 Intended use. Microcircuits conforming to this drawing are intended for use for Government microcircuit applications (original equipment), design applications, and logistics purposes.

6.2 Replaceability. Microcircuits covered by this drawing will replace the same generic device covered by a contractor-prepared specification or drawing.

6.3 Configuration control of SMD's. All proposed changes to existing SMD's will be coordinated with the users of record for the individual documents. This coordination will be accomplished using DD Form 1692, Engineering Change Proposal.

6.4 Record of users. Military and industrial users shall inform Defense Supply Center Columbus (DSCC) when a system application requires configuration control and the applicable SMD. DSCC will maintain a record of users and this list will be used for coordination and distribution of changes to the drawings. Users of drawings covering microelectronics devices (FSC 5962) should contact DSCC-VA, telephone (614) 692-0544.

6.5 Comments. Comments on this drawing should be directed to DSCC-VA, Columbus, Ohio 43218-3990, or telephone (614) 692-0547

6.6 Approved sources of supply. Approved sources of supply are listed in MIL-HDBK-103. The vendors listed in MIL-HDBK-103 have agreed to this drawing and a certificate of compliance (see 3.6 herein) has been submitted to and accepted by DSCC-VA.

STANDARD MICROCIRCUIT DRAWING DEFENSE SUPPLY CENTER COLUMBUS COLUMBUS, OHIO 43218-3990	SIZE A		5962-87776
		REVISION LEVEL J	SHEET 19

STANDARD MICROCIRCUIT DRAWING BULLETIN

DATE: 06-01-11

Approved sources of supply for SMD 5962-87776 are listed below for immediate acquisition information only and shall be added to MIL-HDBK-103 and QML-38535 during the next revision. MIL-HDBK-103 and QML-38535 will be revised to include the addition or deletion of sources. The vendors listed below have agreed to this drawing and a certificate of compliance has been submitted to and accepted by DSCC-VA. This information information bulletin is superseded by the next dated revision of MIL-HDBK-103 and QML-38535. DSCC maintains an online database of all current sources of supply at <http://www.dscclia.mil/Programs/Smcr/>.

Standard microcircuit drawing PIN <u>1/</u>	Vendor CAGE number	Vendor similar PIN <u>2/</u>
5962-8777601MA	69210	OM1812SM/883B
5962-8777601NA	69210	OM1812NM/883B
	<u>3/</u>	SDP7812ANMD
5962-8777601PA	U3158	IP7812AJ-DESC
5962-8777601TA	U3158	IP7812AG-DESC
	<u>3/</u>	UC7812AG/883B
	69210	OM7812AH/883B
	34333	SG7812AG/883B
	<u>3/</u>	SDP7812ATMD
5962-8777601UA	U3158	IP7812AIG-DESC
	<u>3/</u>	FM812S7
	34333	SG7812AIG/883B
	<u>3/</u>	UC7812AIG/883B
	69210	OM7812AIH/883B
	<u>3/</u>	SDP7812AUMD
5962F8777601UA	<u>3/</u>	OMR1812STM/883B
5962-8777601XA	U3158	IP78M12AH-DESC
	34333	SG7812AT/883B

STANDARD MICROCIRCUIT DRAWING BULLETIN - Continued

Standard microcircuit drawing PIN <u>1/</u>	Vendor CAGE number	Vendor similar PIN <u>2/</u>
5962-8777601YA	U3158	IP7812AK-DESC
	34333	SG7812AK/883B
	<u>3/</u>	UC7812AK/883B
	69210	OM1812NK/883B
5962-8777601ZA	U3158	IP7812AR-DESC
	34333	SG7812AR/883B
	<u>3/</u>	SDP7812AZMD
5962-87776012A	34333	SG7812AL/883B
	69210	OM1812N2/883B
	<u>3/</u>	SDP7812A2MD
5962-87776014A	69210	OM1812SRM
5962-87776015A	69210	OM1812N5M
5962-8777602PA	U3158	IP78M12J-DESC
	<u>3/</u>	UA78M12MJGB
5962-8777602XA	U3158	IP78M12H-DESC
5962-87776022A	<u>3/</u>	UA78M12MFKB

1/ The lead finish shown for each PIN representing a hermetic package is the most readily available from the manufacturer listed for that part. If the desired lead finish is not listed contact the vendor to determine its availability.

2/ **Caution.** Do not use this number for item acquisition. Items acquired to this number may not satisfy the performance requirements of this drawing.

3/ Not available from an approved source of supply.

STANDARD MICROCIRCUIT DRAWING BULLETIN - Continued

<u>Vendor CAGE number</u>	<u>Vendor name and address</u>
U3158	SEMELAB PLC Coventry Road, Lutterworth, Leicestershire LE174JB United Kingdom
34333	Microsemi Integrated Products 11861 Western Avenue Garden Grove, CA 92841-2119
69210	International Rectifier 205 Crawford Street Leominster, MA 01453-2353

The information contained herein is disseminated for convenience only and the Government assumes no liability whatsoever for any inaccuracies in the information bulletin.